

Ions, electrons, and ionizing radiations / by James Arnold Crowther.

Contributors

Crowther, James Arnold, 1883-1950.

Publication/Creation

London : E. Arnold, 1919.

Persistent URL

<https://wellcomecollection.org/works/qj5wx6yf>

License and attribution

This work has been identified as being free of known restrictions under copyright law, including all related and neighbouring rights and is being made available under the Creative Commons, Public Domain Mark.

You can copy, modify, distribute and perform the work, even for commercial purposes, without asking permission.



Wellcome Collection
183 Euston Road
London NW1 2BE UK
T +44 (0)20 7611 8722
E library@wellcomecollection.org
<https://wellcomecollection.org>



LONDON HOSPITAL, MEDICAL COLLEGE

THIS BOOK
IS NO LONGER
THE PROPERTY OF
THE LONDON HOSPITAL
MEDICAL COLLEGE
LIBRARY



22102114804

Med
K42061

Chemical Laboratory

LONDON HOSPITAL MEDICAL COLLEGE

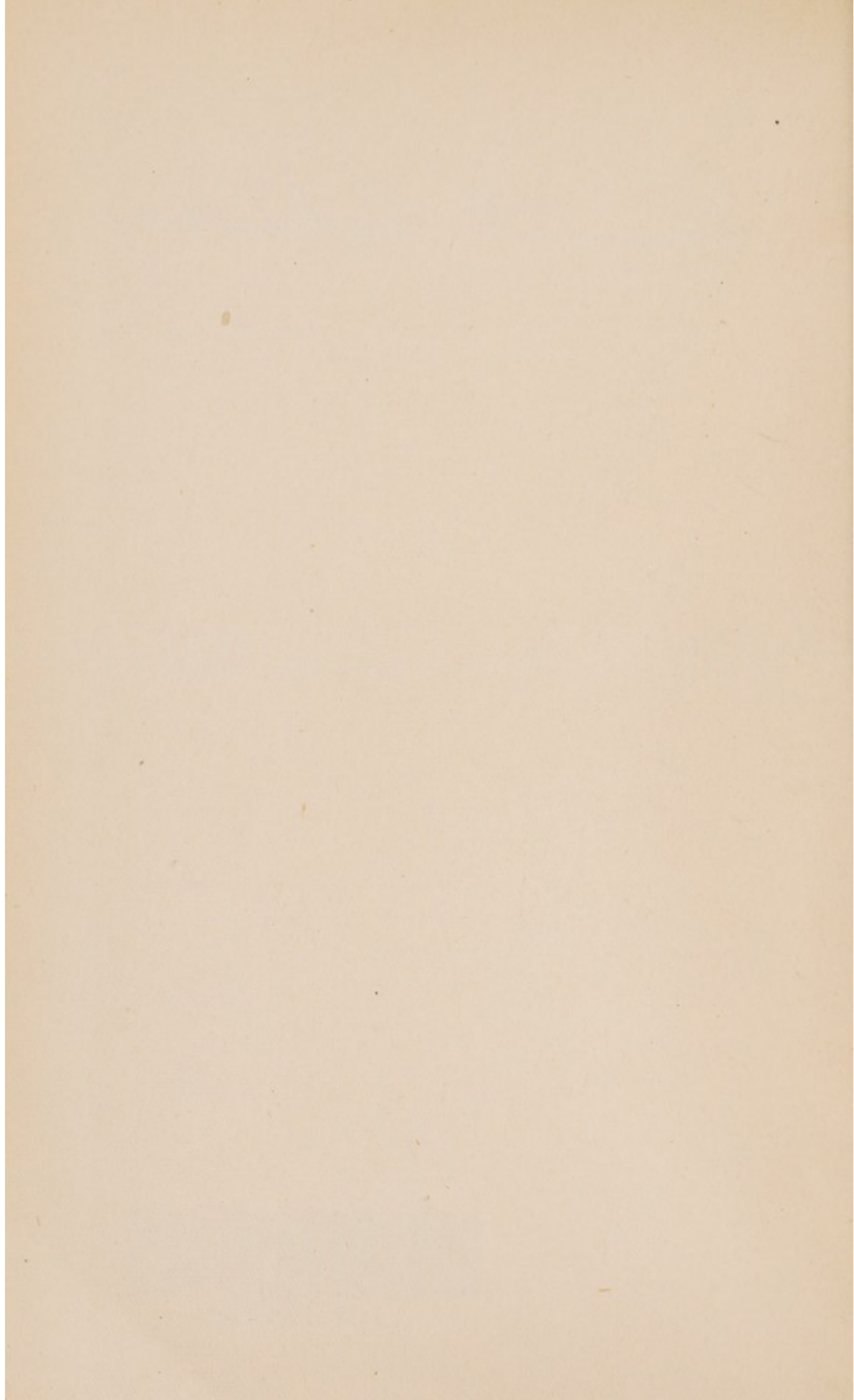

IONS, ELECTRONS,
AND
IONIZING RADIATIONS



IONS, ELECTRONS,
AND
IONIZING RADIATIONS

BY

JAMES ARNOLD CROWTHER, Sc.D.

SOMETIME FELLOW OF ST JOHN'S COLLEGE
UNIVERSITY DEMONSTRATOR IN EXPERIMENTAL PHYSICS
IN THE CAVENDISH LABORATORY, CAMBRIDGE

LONDON
EDWARD ARNOLD

1919

(All rights reserved)

5722

16662089

300681

WELLCOME INSTITUTE LIBRARY	
Coll.	welMOmec
Call No.	
	WN

PREFACE

IN bringing forward yet another book on the subject which, for want of a brief comprehensive title, I have been compelled to describe as Ions, Electrons, and Ionizing Radiations it seems desirable to indicate briefly the purpose it is intended to fulfil. It is not a popular exposition of the "new Physics," nor is it a compendious synopsis of the whole subject. The subject is in fact now so extensive that it is doubtful if such a treatise could be produced in less than half a dozen volumes. The present volume is intended solely as a text-book from which students who have been grounded in the more elementary portions of Physics might obtain a systematic knowledge of its latest developments. The subject has now reached such dimensions that a student entering upon it for the first time needs the same help and guidance which is already provided for him in other branches of Physics by numerous text-books, elementary and advanced. This need I have attempted to supply.

In doing so I have found myself compelled to exercise the liberties which the writer of any text-book must take with his material, if his purpose in writing is to be fulfilled. I have selected freely from the great mass of experimental researches and theories the most fundamental, most important, and best established, and have arranged them in the order which seemed most straightforward and easy for the student. The great classical experiments in the subject I have endeavoured to describe in some detail, exactly as they were first performed, even when their method has been improved upon by later experimenters. Experiments such as those of Sir J. J. Thomson on the cathode rays, and Kaufmann on the variation of mass with velocity, like Faraday's experiments on electro-magnetic induction of currents and Joule's determination of the Mechanical Equivalent of Heat, are landmarks in the history of progress

and should be preserved as far as possible intact. In the case of many less epoch-making experiments I have felt at liberty to omit or to modify unimportant details where such changes seemed necessary to make the principles involved clearer to the student

In the same way I have simplified the mathematical treatment of the subject wherever possible, not merely in the interests of students whose mathematical equipment is not very extensive, but also because I have found in practice that even in the case of students who are better equipped a real understanding of the argument and of the physical principles involved in it is more readily attained if the mathematical analysis is not too complicated. The ability to reproduce several pages of mathematical symbols is no measure of, and certainly no adequate substitute for, a real understanding of the nature of the argument.

Within its limits it is hoped that the present volume furnishes a reasonably complete account of the present state of the subject; that nothing of real importance has been omitted, nor too many unimportant details included, to the confusion of the clear outlines of the subject.

In a book which from its nature lays no claim to originality, no detailed list of acknowledgements is required. I have consulted freely all the books and memoirs given in the list of references at the end of this volume, together with numerous original papers and memoirs on the subject. I am, perhaps, even more indebted to that fund of information and ideas, which is acquired almost unconsciously by one who has had the privilege of working in the Cavendish Laboratory under Professor Sir J. J. Thomson, and of enjoying there the conversation of many of those whose researches have made the present volume possible. I should also like to express my best thanks to Mr C. T. R. Wilson for allowing me to reproduce the photographs of tracks of ionizing particles which form figures 16, 17 and 18, and to Mr E. V. Appleton for his kindness in reading the proofs.

J. A. C

CAMBRIDGE,
August, 1919

CONTENTS

CHAPTER I

INTRODUCTION

ART.	PAGE
1. Electrons	1
2. Conduction through gases	3
3. Radio-active substances and their radiations	4

CHAPTER II

THE PASSAGE OF A CURRENT THROUGH AN IONIZED GAS

4. Conductivity of gases in the normal state	7
5. Ionization theory of gaseous conduction	9
6. Methods of measuring the current through a gas	10
7. Measuring instruments	11
8. The ionization chamber	14
9. Variation of the current with the potential across the gas	15
10. Variation of the saturation current with the distance between the electrodes, and the pressure of the gas	17
11. Theory of conduction through gases	17
12. Motion of the ions under a uniform electric field	19
13. Theoretical relation between current and potential	20

CHAPTER III

THE PROPERTIES OF THE GASEOUS IONS

14. Measurement of ionic mobilities. Rutherford's method, Langevin's method	23
15. Mobilities of the ions in different gases	27
16. Approximate calculation of the mobility of an ion	28
17. Effect of pressure on the mobility of the ions	30
18. Measurement of the coefficient of recombination	32

CHAPTER IV

THE CHARGE ON AN ION

ART.		PAGE
19.	Condensation of water drops on ions	36
20.	C. T. R. Wilson's cloud experiments	37
21.	C. T. R. Wilson's later condensation experiments	41
22.	Application to the determination of e . Thomson's method. Balancing method	41
23.	Millikan's experimental determination of e	43
24.	Perrin's determination of e from the Brownian movement	46
25.	Summary of results	50

CHAPTER V

IONIZATION BY COLLISION—THE
SPARK DISCHARGE

26.	Ionization currents with large voltages	52
27.	Difference in the effects produced by positive and negative ions	54
28.	Expression for the current through the gas when ionization by collision occurs	56
29.	Townsend's experiments	57
30.	Variation of a with pressure and field	60
31.	Average velocity required to produce ionization	62
32.	Ionization by collisions with the positive ions	63
33.	The spark discharge	65
34.	Sparking potential for parallel plate electrodes	67
35.	Paschen's law	69
36.	Variation of sparking potential with temperature	70
37.	The brush discharge	70
38.	The dark discharge	72

CHAPTER VI

THE PHENOMENA OF THE DISCHARGE TUBE

39.	Phenomena of the discharge in a gas at low pressure	73
40.	Investigation of the intensity of the field in various parts of the discharge	75
41.	Number of ions in various parts of the discharge	77
42.	The cathode fall of potential	78
43.	Theory of the discharge	79

CHAPTER VII

CATHODE RAYS AND POSITIVE RAYS

ART.		PAGE
44.	Cathode rays	83
45.	Motion of a charged particle under the action of a magnetic field	87
46.	Motion of a charged particle under the joint action of electric and magnetic forces	89
47.	Thomson's method of determining e/m and v for cathode rays	92
48.	Kaufmann's method of determining e/m	95
49.	The magnetic spectrum	95
50.	Numerical values of e/m for electrons from various sources .	96
51.	Direct measurement of the velocity of cathode rays.	97
52.	The positive rays in a discharge tube	98
53.	Thomson's experiments on the positive rays	99
54.	Positive ray parabolas	102
55.	Negative parabolas	106
56.	Positive ray analysis	107
57.	Electrical method of measuring positive rays	108
58.	Secondary effects	109

CHAPTER VIII

EMISSION OF ELECTRICITY BY HOT BODIES

59.	Loss of charge from a hot body	110
60.	Nature of the negative thermions	111
61.	Variation of the current with temperature	112
62.	Theory of thermionic emission	112
63.	Evidence for the theory of thermionic emission	115
64.	Discharge of negative electricity by various substances	116
65.	Discharge of positive electricity	118
66.	Conductivity of flames	120
67.	Distribution of potential between two electrodes in a flame	121
68.	Conductivity of salt vapours	124
69.	Maximum current carried by salt vapours	125

CHAPTER IX

PHOTO-ELECTRICITY

ART.	PAGE
70. The photo-electric effect	126
71. Ionization of gases by ultra-violet light	127
72. Velocity of emission of the photo-electrons	129
73. The "quantum" theory of radiation	130
74. Distribution of velocities among the photo-electrons	132
75. Magnitude of the photo-electric effect	133
76. Variation of the photo-electric effect with wave length and state of polarization	135
77. Photo-electric fatigue	137
78. Photo-electric effect in non-metals	138
79. Phosphorescence and the photo-electric effect	139

CHAPTER X

X-RAYS

80. Production of X-rays	140
81. Radiations emitted by the stoppage of a moving electrified particle	143
82. The scattering of X-rays by matter	147
83. Polarization of the scattered radiation	148
84. Energy of the scattered radiation	150
85. Interference phenomena with X-rays	151
86. Theory of Laue's experiments on the diffraction of X-rays by crystals	153
87. Reflection of X-rays by crystal planes. Bragg's experiments	156
88. The X-ray spectrometer	160
89. Determination of the wave length of X-rays	162
90. The X-ray spectra. Characteristic radiation	165
91. Conditions for the excitation of characteristic radiation	168
92. Characteristic secondary radiation	170
93. Absorption of X-rays	173
94. Secondary corpuscular radiation	176
95. Ionization by X-rays	178

CHAPTER XI

THE α -RAYS

ART.		PAGE
96.	Properties and nature of the α -rays	180
97.	Nature of the α -particle	181
98.	Determination of the charge on an α -particle	181
99.	Passage of the α -rays through matter	184
100.	Bragg's experiments on the range of the α -particles	187
101.	The stopping power of an atom for α -particles	191
102.	The scattering of the α -particles	192

CHAPTER XII

THE β - AND γ -RADIATIONS

103.	Nature of the β -rays	195
104.	Determination of e/m and v for the β -rays	196
105.	Electromagnetic mass	198
106.	Variation of the mass of an electron with velocity. Bucherer's experiments	200
107.	Passage of the β -rays through matter	202
108.	The scattering of the β -rays	204
109.	Nature and properties of the γ -rays	206
110.	Absorption of γ -rays	207
111.	Secondary γ -rays	207
112.	Production of γ -rays from β -rays	208
113.	Characteristic γ -radiations	209
114.	Determination of the wave length of γ -rays	210

CHAPTER XIII

RADIO-ACTIVE CHANGES

115.	Disintegration of uranium	212
116.	Theory of radio-active change	215
117.	Theory of successive transformations	217
118.	Radio-active equilibrium	220

CHAPTER XIV

RADIUM AND ITS PRODUCTS

ART.		PAGE
119.	The nature and properties of radium	225
120.	Radium emanation	226
121.	Elementary nature of radium emanation	227
122.	Rate of decay of radium emanation	228
123.	Rate of escape of the emanation	230
124.	Measurement of the volume of the emanation in equilibrium with one gram of radium	230
125.	The active deposit from radium emanation	231
126.	Recoil atoms	233
127.	Analysis of the active deposit of rapid change	234
128.	Separation of the products by the method of "recoil." Com- plex nature of radium C	238
129.	The radio-active product of slow change	240
130.	The radio-activity of thorium and actinium. Tables of radio- active series	241

CHAPTER XV

SOME PROBLEMS IN RADIO-ACTIVITY

131.	Uranium and the origin of radium	244
132.	Production of helium from uranium. Geological age	245
133.	The end-product of the uranium chain	246
134.	The heating effect of radium	246
135.	The range of the α -particles and the period of decay	250
136.	Radio-activity of ordinary matter	250

CHAPTER XVI

THE ELECTRON THEORY OF MATTER

137.	The constitution of the atom	253
138.	Arrangement of electrons in an atom	256
139.	Chemical properties of the elements a result of electron grouping	258
140.	The nature of the nucleus. Radio-activity	260
141.	Emission of light. The Zeeman effect	261
142.	Electron theory of metallic conduction	265
143.	Relation of electrical and thermal conductivities. Law of Wiedemann and Franz	267
144.	Thermoelectric effects	269
	TABLE OF ATOMIC DATA	271
	REFERENCES	272
	INDEX	273

CHAPTER I

INTRODUCTION

1. **Electrons.** The phenomena which form the subject of the present text-book have been, in the main, brought to light within the last twenty-five years, and represent a mass of research which in its volume and its rapidity of growth is unprecedented in the annals of physical science. Progress has been made upon three main lines, but these are so intermingled, and break in upon each other and support each other at so many points that it is impossible to deal with one without assuming at least a casual acquaintance with the main results of the others. Owing partly to the newness of the subject, but mainly to its magnitude the accounts given of the subject in text-books on general electricity are usually somewhat inadequate, and such knowledge cannot be postulated in a student of physics who approaches the subject as a whole for the first time. It will be desirable therefore before commencing a detailed study of the phenomena to state broadly the results and conclusions at which we hope to arrive.

Historically the subject may be said to have taken its origin in experiments on the discharge of electricity through gases at low pressure contained in some form of discharge tube. When a high tension discharge is sent through a gas at low pressure (say some fraction of a millimetre of mercury) the gas becomes luminous shewing a series of glows and striae (see Fig. 31), which are often very beautiful, but which, at the time of their discovery, were very difficult to explain on the current theories of the time. If the pressure is sufficiently low, a series of streamers known as the cathode rays can be observed proceeding in straight lines from the cathode and crossing the other glows in the tube. The experiments of Sir William Crookes led him to the conclusion that these rays were material

in nature, consisting of some new manifestation of matter to which he gave the term *radiant matter*. On the other hand there existed, especially in Germany, a large school of thought which was inclined to assign the effects to some sort of wave motion in the ether, probably of very short wave length, and thus analogous to ultra-violet light.

The controversy raged hotly and somewhat inconclusively for nearly twenty years. It was not until 1895 that Sir J. J. Thomson following up the work of Perrin proved conclusively that the cathode rays consisted of negatively charged particles. These experiments may be said to mark a new epoch in physical science. The method evolved enabled him to measure not only the velocity of the particles but also the ratio of the mass of an individual particle to the charge upon it. It was found that the velocity of the particles was a function of the difference of potential across the terminals of the discharge tube. In general its value lay between 10^9 and 10^{10} cm. per second, or roughly between one-thirtieth and one-third of that of light. The ratio of the mass of a cathode particle to the charge upon it was, however, within the limits of experimental error, perfectly constant and independent of all the circumstances of the experiment. It was found to have the same value no matter what the potential across the tube, no matter what the chemical nature of the substance used as the cathode, and no matter what the nature and pressure of the residual gas within the tube. It was in fact a universal constant. These particles can be produced from and thus are contained in all chemical substances.

It was later found possible to determine separately both the mass and the charge on these particles or *electrons* as they are now called. It was found that the mass of an electron was very small compared with that of the lightest known atom, being only about 1/1800th of that of a hydrogen atom. The mass of an electron has been found to be 8.9×10^{-28} gm. and its charge 4.7×10^{-10} electrostatic units or 1.57×10^{-20} electromagnetic units of charge. The radius of the electron has been estimated at approximately 1.9×10^{-13} cm. The radius of an atom is about 10^{-8} cm. The radius of an electron is thus about

1/50,000th of that of the atom. Such electrons must, as we have already seen, form a part of every known kind of matter.

No charge has yet been observed which is smaller than that on the electron. Every charge observed, which is sufficiently small to be directly compared with that of the electron, has been found to be an exact integral multiple of it. We are thus led to the conclusion that *electricity is atomic in structure*; the smallest possible unit of charge being that of the electron, which thus constitutes our fundamental unit of electricity. Moreover it can be shewn that the "mass" of the electron is entirely an electrical effect, and is due solely to the charge which it carries. The electron therefore constitutes a real atom of electricity.

2. Conduction through gases. The investigation of the electron and its properties was given a further stimulus by the discovery which followed hard upon it, that gases which ordinarily are among our best insulators of electricity can be rendered partially conducting by the action of certain agents upon them. The discovery of X-rays by Röntgen in 1895 was quickly followed by the observation that charged bodies rapidly lost their charge when an X-ray bulb was worked in their vicinity. This loss of charge was shewn to take place through the surrounding air, which became temporarily conducting. It was shewn that the conductivity of the gas was due to the creation in it of positively and negatively charged systems, which by analogy with the carriers in electrolytic conduction were termed *gaseous ions*. These ions must, on the electron theory, consist of molecules of the gas which have lost or gained one or more electrons. Further investigation shewed that similar properties could be conferred upon a gas by the action of cathode rays. Owing partly to the small number of the carriers, partly to the great simplicity in the structure of gases, a study of these carriers has thrown considerable light on some obscure parts of science.

The existence of these gaseous ions was controverted for some little time, but no other explanation has been found adequate to explain the phenomena. Their objective reality

was placed beyond all reasonable doubt by the experiments of C. T. R. Wilson, who shewed that these ions could serve as nuclei for the condensation of drops of water in a supersaturated space. The ions were thus rendered visible by the deposition of the water upon them, and could readily be observed, and even photographed. Photographs such as that of Fig. 17, which represents the track of a cathode particle through air, make it certain that the production of conductivity in a gas by these ionizing radiations is due to the formation in the gas of definite charged systems.

3. Radio-active substances and their radiations. The discovery of X-rays and the somewhat startling manner in which these rays were able to penetrate considerable thicknesses of materials which were opaque to ordinary light naturally led to an exhaustive search among natural substances to see if any of these emitted radiations having properties at all resembling those of X-rays. The research was pursued with vigour by Becquerel and afterwards by the Curies, and led to the discovery that radiations possessing the properties of penetrating opaque substances and of causing conductivity in gases were emitted by the salts of uranium and thorium. The subsequent observation that naturally occurring ores of uranium were several times more active than the metal itself led to the isolation of radium, and subsequently of other similar substances which were found to possess these properties in a very remarkable degree. Substances which are capable of emitting spontaneously these ionizing radiations are classed together under the title *radio-active substances*.

It has been shewn that each radio-active substance is a definite chemical element, and that its activity is due to a spontaneous decomposition or disintegration as it is usually termed of the radio-active atom into one of smaller weight, the process taking place according to definite laws which have been determined. This naturally leads us to the view that the atoms of the various chemical elements are not essentially different in kind but represent complex systems built up out of one or two elementary forms according to certain definite laws.

On further investigation it was found that the rays given out by these radio-active substances were of three kinds, which were denoted by the non-committal symbols α , β , and γ . This nomenclature is convenient and has been retained. All three types possess in common with X-rays the properties of converting a gas into a conductor, of affecting a photographic plate, and of causing luminescence in a fluorescent screen. In other respects however they differ very markedly in their properties.

The α -rays were found to be positively charged and were of the size of atoms. They have recently been proved to consist of helium atoms which have lost two electrons and thus possess a positive charge of $2 \times (4.7 \times 10^{-10})$ or 9.4×10^{-10} e.s.u. They are very easily absorbed in matter being completely stopped by 1/10th mm. of aluminium or a few centimetres of air at atmospheric pressure. They produce very intense ionization in the gas through which they pass. Their velocity depends on the substance from which they are ejected; their nature is always the same.

The β -rays on the other hand carry a negative charge. They can penetrate much greater thicknesses of matter than the α -rays, producing measurable effects through a thickness of even a centimetre of aluminium. The ionization they produce in a gas is however small compared with that of the α -rays. Their nature is found to be identical with that of the cathode rays. They consist of electrons, carrying the universal electronic charge, and differ from the cathode rays only in velocity. Whereas it is difficult to obtain cathode rays with a velocity much greater than one-tenth that of light, the β -rays from radium possess velocities which range up to within one or two per cent. of that of light itself.

The γ -rays are exceedingly penetrating, those from radium producing quite measurable effects through a thickness of 20 or 30 cms. of iron. Their ionizing power is small, as the fraction of their energy which can be absorbed by any reasonable thickness of gas is minute. They are now known to be pulses in the ether of very short wave length (about 10^{-9} cm.). X-rays are also ether pulses but of a considerably longer wave length;

generally about 10^{-8} cm. The γ -rays and the X-rays thus represent the extreme end of the electromagnetic wave scale; in other words, they are ultra-violet rays of extremely short wave length. Between the radiations usually denoted as ultra-violet and X-rays there is however still a wide gulf, the shortest ultra-violet rays at present known having a wave length of rather more than 10^{-5} cms. In spite of this wide gap we shall see that these ultra-violet rays have many properties in common with X-rays, including the property of producing conductivity in a gas.

CHAPTER II

PASSAGE OF A CURRENT THROUGH AN IONIZED GAS

4. **Conductivity of gases in the normal state.** A gas in its normal state is one of the best insulators of electricity known. It was indeed for a long time a moot point whether gases conducted electricity at all, and whether the gradual loss of charge which always occurs with charged bodies might not be due to slight defects in the insulating qualities of the solid materials used to support the body. The matter was settled by C. T. R. Wilson using the ingenious apparatus shewn in Fig. 1. The gas is enclosed in a large spherical vessel which is silvered inside to make it conducting. The charged system takes the form of a brass rod carrying a pair of thin gold leaves. In this way the charged body is made to serve as its own electroscope. Since the electrical capacity of a system such as this is very small,

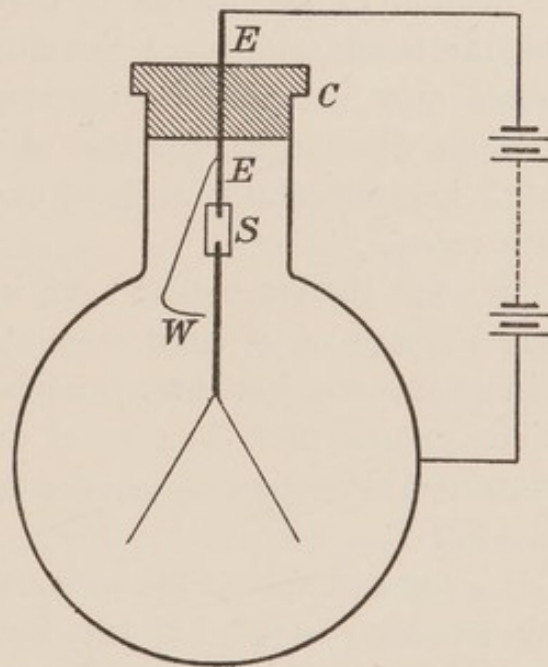

Fig. 1

a very small loss of charge will be sufficient to produce a large fall of potential, and hence a considerable movement of the gold leaves, which were closely observed with a long focus microscope having a micrometer scale in the eye-piece. The apparatus was thus exceedingly sensitive.

The end of the rod carrying the gold leaves was fused into a block of sulphur *S*; sulphur when carefully prepared being an exceedingly good insulator. The sulphur block was supported

by another brass rod E passing through an ebonite cork in the neck of the vessel.

The rod E is charged to some suitable potential (about 400 volts) and is maintained at this potential throughout the experiment, most conveniently by connecting it to one end of a cabinet of small accumulator cells, the other terminal of which was connected to the silver coating of the vessel. Contact between E and the gold leaves can be made, when required, by means of the fine iron wire W which can be attracted by a magnet so as to touch the gold leaf system, and then allowed to fly back leaving the latter perfectly insulated. The gold leaves are then at the potential of E .

Since the latter remains at the same potential throughout, any leak across the sulphur plug will only tend to keep the deflection of the leaves at their original value. Any loss of charge must take place therefore across the gas. Even under these circumstances it was found that the leaves gradually became discharged, the loss of charge per second being about $10^{-8} V$ electrostatic units of charge where V is the volume of the vessel.

We see therefore that even in its normal state a gas allows the passage of a small current of electricity. Under certain circumstances, however, the gas acquires a conductivity many times greater than the normal, and these currents have acquired considerable importance in the development of modern electrical theory.

If, for example, a quantity of radium is brought near the electroscope of Fig. 1, the leaves collapse with considerable rapidity and similar effects are observed if an X-ray tube is worked in the vicinity. Gases drawn from a Bunsen flame also possess temporarily the power to discharge a conductor, and this capacity is enormously increased if the flame is fed with a volatile salt such as sodium or potassium chloride.

The power to discharge a conductor persists in the gas for some little time after the active agent has been removed, and is transferred from place to place with the air. Thus if air from a Bunsen flame (Fig. 2) is drawn in a continuous current into an electroscope, the latter will be discharged.

If, however, the gas is filtered through tightly packed glass wool or passed through water the effect disappears, and it can also be removed by subjecting the gas to a strong electric field. It disappears spontaneously if the gas is allowed to stand for a few seconds.

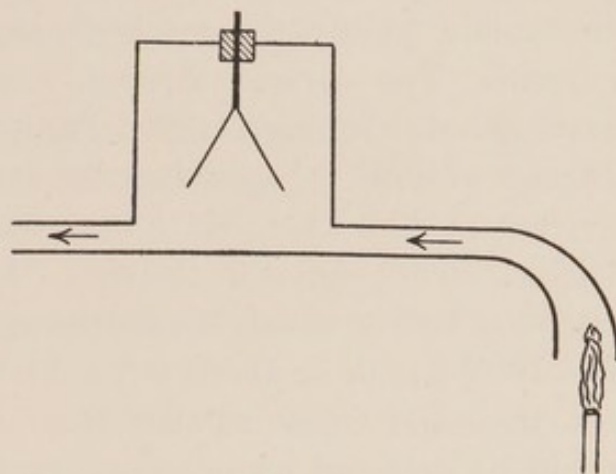

Fig. 2

5. Ionization theory of gaseous conduction.

The phenomena of the passage of electricity through gases can best

be explained by assuming that charged systems are set up in the gas by the action of the various agencies, and that these charged systems or gaseous ions, as they are called, convey the current across the gas by moving in opposite directions through the gas under the action of the electrostatic field set up by the charged body, in much the same way that a current is conveyed through the solution of an electrolyte by the motion of the positively and negatively charged electrolytic ions.

Thus if the body has a positive charge and is surrounded by a gas containing gaseous ions the negative ions will be attracted to the body, and giving up their charges to it will gradually bring about its discharge. The difference between electrolytic and gaseous conduction which experimentally is very marked is due to two principal causes. In the first place the electrolytic ions are formed by the mere process of solution and persist so long as the salt remains dissolved, while the gaseous ions are only formed by the action of an external agency, which we may call the *ionizing agent*, and gradually disappear when the latter is removed. In the second place the number of charged systems present in a gas under the most intense ionizing agent is only a very small fraction of those present even in very dilute electrolytic solutions.

6. **Methods of measuring the current through a gas.** Before proceeding to describe the phenomena attending the passage of an electric current through gases it will be convenient to explain briefly the methods available for measuring such currents. The current through a normal gas is as we have seen about 10^{-8} electrostatic units (e.s.u.) per unit volume. If the volume of gas is one litre this corresponds to a current of 10^{-5} e.s.u., since current is the rate of flow of electricity. The current through the gas is thus equal to $10^{-5}/3 \times 10^{10}$ in absolute electromagnetic units (e.m.u.), that is $\frac{1}{3} \times 10^{-15}$ e.m.u. or about 3.3×10^{-16} amperes. This is at least ten thousand times smaller than the smallest current which could be detected on our most sensitive galvanometers. Thus even if the conductivity of the gas is increased a thousand times by the ionizing agent the current will still be beyond the range of a galvanometer.

Let Q be the charge at any instant on an electrical conductor of capacity C . The potential of the conductor is given by the equation

$$Q = C \cdot V.$$

The current i through the gas at any instant is given by the rate of loss of charge of the conductor. Thus

$$i = dQ/dt = C \cdot dV/dt \quad . \quad . \quad . \quad (1)$$

since the capacity C is constant.

Thus if the rate of loss of potential can be measured, as for example by measuring the rate of collapse of the leaves of an electroscope, the current through the gas can be calculated when the capacity of the charged system is known. This method was employed by Wilson in his measurements on the conductivity of a normal gas already described.

In this form of measurement the potential across the gas must be adjusted to suit the instrument used. Thus if the gold leaf electroscope requires a potential difference of, say, 100 volts to produce a sensible deflection of the leaves we cannot work with potential differences of less than this amount. It is often, therefore, more convenient to measure the rate at which an insulated conductor receives electric charge from the gas under the action of a field supplied by another electrode immersed

in the gas. The current will again be measured by $i = C \cdot dV/dt$ as before, where C is the combined capacity of the receiving electrode and the measuring instrument, and dV/dt the rate at which the potential of the latter increases.

7. **Measuring instruments.** The instruments used in practice are either the Dolezalek electrometer or some form of

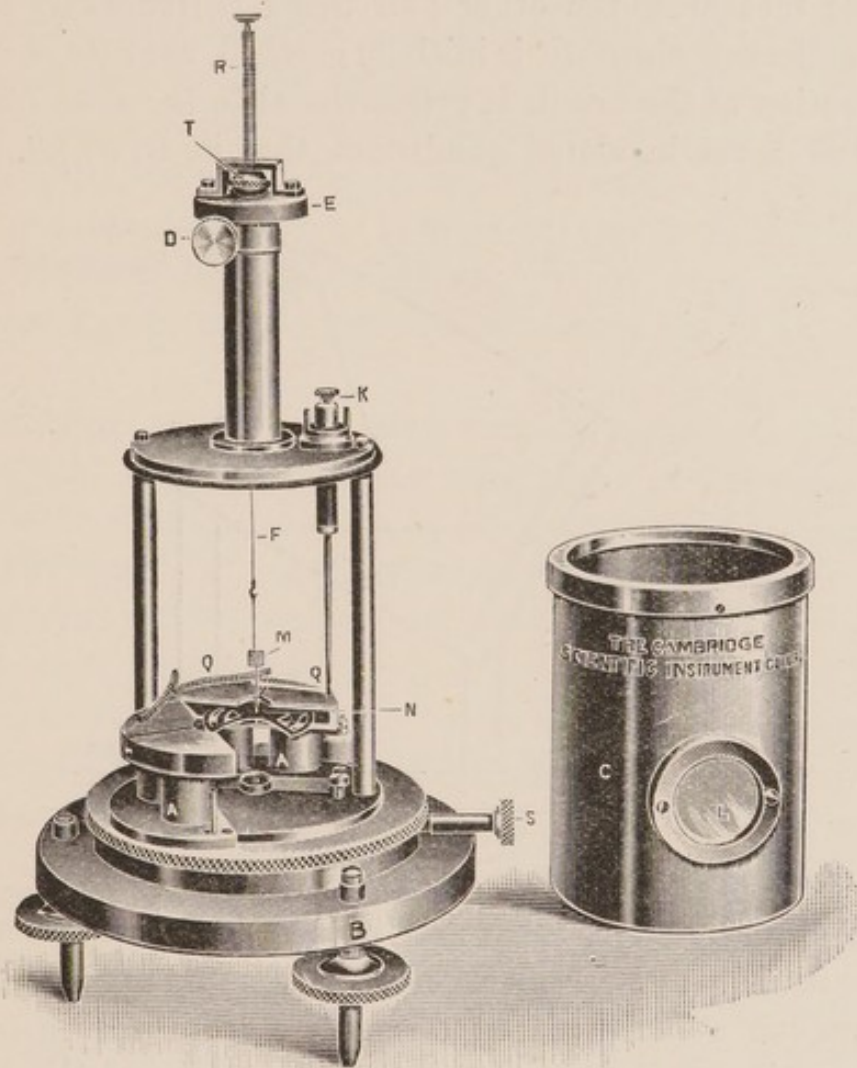

Fig. 3

gold leaf electroscope. The Dolezalek electrometer (see Fig. 3) is an improved form of the quadrant electrometer described in the text-books on electrostatics, in which special attention is paid to obtaining not only a high degree of sensitiveness but also a small capacity. The quadrants are small and are carefully insulated on amber supports. The needle is made as light as possible and supported by a fine strip of phosphor

bronze. The instrument is used heterostatically, the needle being kept at a constant potential of about 120 volts by means of a cabinet of small accumulators. These cabinets are of the greatest service in work of this kind and generally consist of 500 cells arranged so as to give any voltage in steps of 2 volts up to a maximum of 1000 volts. One pair of quadrants of the electrometer is connected to the electrode at which the current is to be measured, the other pair being permanently earthed. If the collecting electrode is initially earthed, the rate of increase of deflection of the needle is proportional to the rate of rise of potential of the insulated quadrants, that is, to dV/dt .

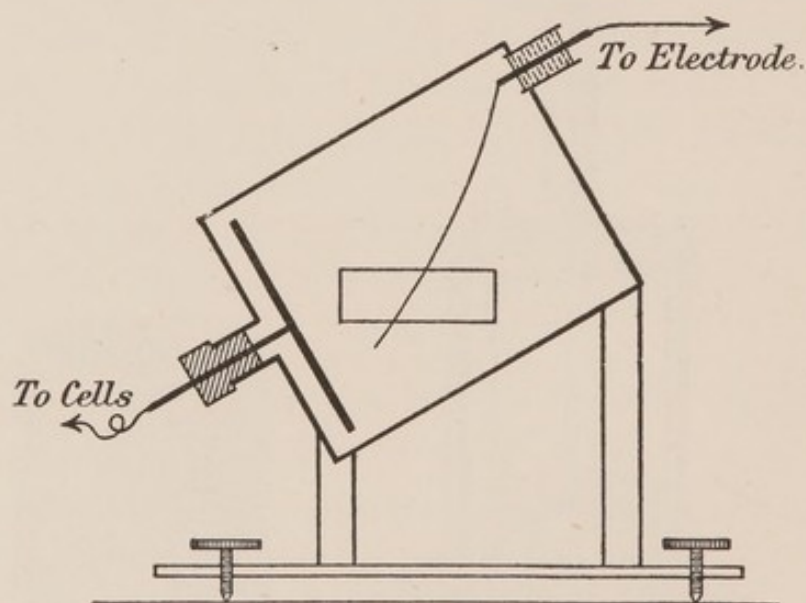

Fig. 4

If the deflection is measured by a reflected beam of light in the usual way, a deflection of 1000 mm. per volt can be obtained on a scale placed one metre from the instrument. The capacity of the electrometer is generally of the order of 50 e.s.u.

The gold leaf electroscope. One form of electroscope has already been described and is still largely employed for certain classes of measurement. A more sensitive form, also due to C. T. R. Wilson, is the tilted electroscope (Fig. 4). In this instrument the gold leaf which is initially at zero potential is attracted outward from the vertical position by a plate

which is charged to some constant potential, usually about 160 volts, by a cabinet of cells. If the plate is positively charged a small negative potential on the leaf will cause it to be attracted still further towards the plate, while a small positive potential will cause it to move towards the vertical position. The position of the gold leaf is read by a microscope with micrometer eyepiece. For certain potentials of the plate, and for a certain position of tilt of the instrument, generally about 30° as in the figure the leaf becomes almost unstable and in this state is very sensitive to slight changes in the potential. The best conditions can only be found by experiment, and the instrument needs an apprenticeship. In skilled hands however it is capable of very accurate results. A sensitiveness of 200 divisions per volt can be obtained, and the capacity can be made very small; it need not exceed one or two electrostatic units.

Comparison of the relative sensitiveness of the electrometer and electroscope. A comparison of the two instruments affords a useful exercise in the principles of the method of measurement. Let us assume that the electrometer gives a deflection of 1000 divisions per volt, and the electroscope 200, and that in each case a rate of deflection of one division in 10 seconds can be measured. In the case of the electrometer this corresponds to a value of dV/dt of 10^{-4} volts per second. The capacity of the instrument is, say, 50 e.s.u., or since one farad or practical unit of capacity is equal to 9×10^{11} e.s.u. the capacity of our electrometer is $\frac{50}{9 \times 10^{11}}$ or approximately 6×10^{-11} farads. The smallest current which can be measured with accuracy is therefore $6 \times 10^{-11} \times 10^{-4}$, that is 6×10^{-15} amperes.

For the electroscope the rate of change of potential is on the same assumptions $1/2000$ volt per sec., while the capacity is, say, 2 e.s.u., or about 2×10^{-12} farads. The smallest measurable current is thus $2 \times 10^{-12} \times \frac{1}{2000}$ or 10^{-15} amperes. Thus, although the electrometer is more sensitive as regards potential, the electroscope is more sensitive to current, owing to its smaller electrostatic capacity.

8. **The ionization chamber.** The actual form of the vessel used for containing, and applying a field to, the gas varies very much with the nature of the effect to be observed. A suitable form for investigating the variation of current with potential, and for many other experiments in which the field needs to be definite, is shewn in Fig. 5.

The gas under investigation is contained in a metal box which is connected to earth, thus serving to shield the electrodes *A* and *B* from any strong electrostatic field. For a similar reason the wire leading from the insulated electrode *A* to the electrometer should also be surrounded by an earthed metal tube (not shewn in the diagram). The electrodes are placed parallel to each other a few centimetres apart; *A* is connected to one

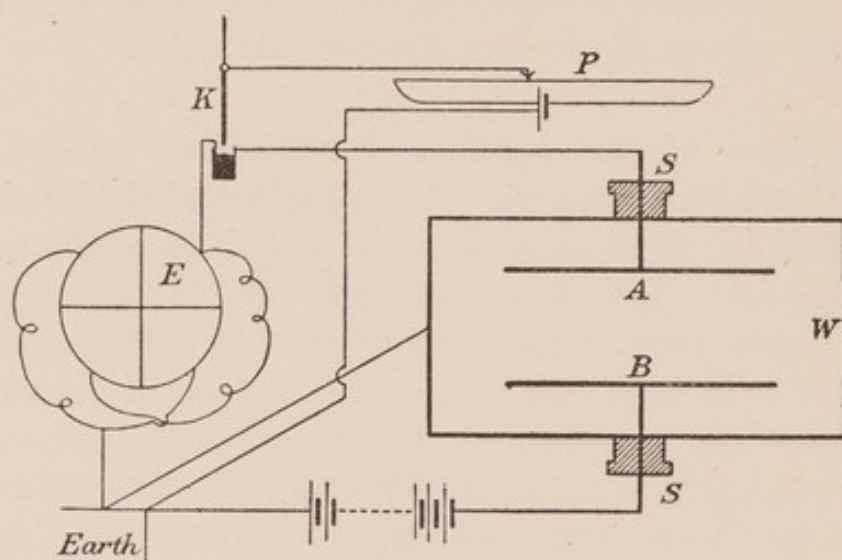

Fig. 5

pair of quadrants of an electrometer, or to the leaf of a tilted electroscope, and *B* is raised to any required potential by means of a cabinet of cells. The system *A* can be placed at zero potential by means of a key *K*, which can be earth-connected. When the key *K* is raised the system *A* is completely insulated, and begins to charge up with electricity of the same sign as the potential of *B*. If *K* is connected to a potentiometer, instead of directly to earth, the system *A* with its attached quadrants can be raised to a suitable known potential, and thus the electrometer can be calibrated; a process which needs to be repeated frequently with these sensitive instruments.

The ionizing agent may be enclosed in the box, but it is generally more convenient to have it outside, in which case a window W of some substance transparent to the ionizing rays, and generally consisting of a very thin sheet of aluminium foil, must be made in the side of the box. The electrodes are insulated from the box by insulating stoppers S, S . The insulation of A is very important, and should be of amber, sulphur, or quartz. The box and its electrodes forms what is known as an *ionization chamber*.

Suppose B is now raised to some constant potential, say, 200 volts positive, while A is earthed by the key K , and the gas exposed to the action of the ionizing agent. The ions in the gas begin to move under the action of the field between the plates, the positive towards A , the negative towards B . As long as the wire K remains in the mercury cup, the potential of A remains zero. As soon as it is withdrawn A begins to charge up positively, and the needle of the electrometer begins to move. Let t be the time taken for the needle to reach the deflection corresponding to a potential V . Then if C is the capacity of A and its connected quadrants, etc., the average current through the gas is given by

$$i = C \cdot \frac{V}{t}.$$

The actual potential corresponding to a given deflection can easily be found by lowering the key K again into the mercury cup, and sliding the end of the wire connected to K along the potentiometer wire until the deflection reaches the given value. The corresponding potential can then be read off on the potentiometer. For very accurate work, particularly with electroscopes, it is generally desirable to repeat this calibration after every reading.

9. Variation of the current with the potential across the gas. Suppose now the potential of B is gradually raised. For simplicity we will suppose that the maximum voltage acquired by A in charging up is not allowed to rise sufficiently to affect materially the potential difference between the plates. We can then study the magnitude of the current through the

ionized gas for different potential differences between the plates. In the case of a metallic conductor or of an electrolyte with non-polarizable electrodes, the relation is expressed by Ohm's law, that is, the current is simply proportional to the potential difference. The relation for a gas is, however, more complex, and is represented by a curve such as that of Fig. 6 which is plotted from an actual set of readings.

At first, and for very small voltages, say, less than one volt, the current is approximately proportional to the applied potential difference; that is at this stage the gas obeys Ohm's law, though probably not with the same degree of accuracy as a metallic conductor. As, however, the potential of B is

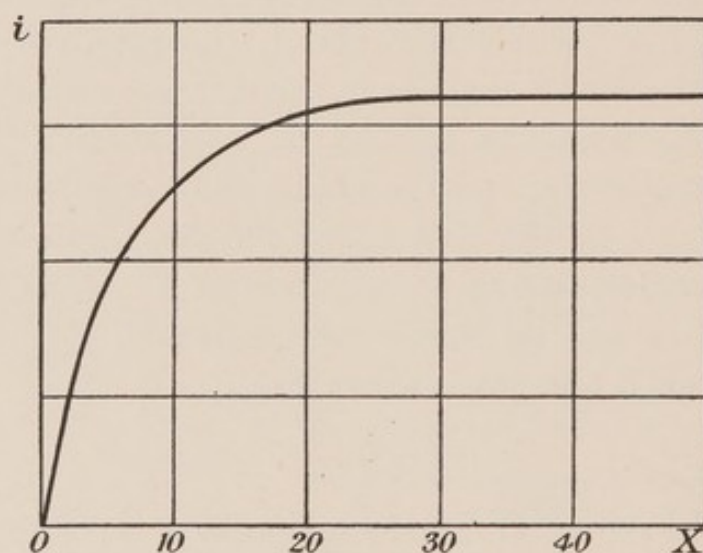

Fig. 6

raised above a certain value which depends on the nature and pressure of the gas, the distance apart of the electrodes and the intensity of ionization, a stage is reached when the current falls appreciably below the value which would be given by Ohm's law.

If the potential is pushed still higher a point is reached at which further increase in the potential of B produces no further increase in the current through the gas. After this point *the current is independent of the voltage*. This maximum current is called the *saturation current* through the gas, and the potential necessary to produce this current is known as the *saturation voltage*. The actual value of the saturation voltage depends

upon the distance apart of the electrodes, and the intensity of the ionization in the gas. Except in cases of very intense ionization, a field of from 20 to 30 volts per cm. between the electrodes is sufficient to produce the saturation current.

10. Variation of the saturation current with the distance between the electrodes, and the pressure of the gas. If one of the electrodes is made movable the variation of the saturation current with the distance apart of the electrodes can be studied. In the case of a metallic conductor the current for a given potential difference is inversely proportional to the length of the conductor, and a similar result holds for electrolytes. For gases however, if we arrange that the effect of the ionizing agent is the same in all parts of the gas, the saturation current through the gas is directly proportional to the distance apart of the electrodes. It can also be shewn, by using electrodes of different sizes, to be directly proportional to the area of the electrodes. If the pressure of the gas is varied it is found that the saturation current is directly proportional to the pressure of the gas. In other words *the saturation current through a gas is directly proportional to the mass of gas between the electrodes.*

The effects when the current is not saturated are in general very complex, and need not concern us here.

11. Theory of conduction through gases. Let us assume that the ionizing agent is producing ions uniformly throughout the gas and at a constant rate, so that q pairs of ions are formed per c.c. per second in the gas. These ions are charged positively and negatively, and since the gas as a whole is uncharged, the number of positive and negative systems must be equal, supposing that each carries a charge of the same magnitude e .

In general ions may be lost by the gas in three ways. In the first place since the ions are oppositely charged they attract each other according to the ordinary laws of electrostatics. On collision their charges may neutralise each other, and the ions return to their ordinary uncharged state. The chances of a given positively charged ion meeting a negative ion in a given

time is obviously proportional to the number of negative ions present per c.c., while the number of positive ions finding partners in a given time is proportional to the number of positive ions actually present per c.c. of the gas. The rate at which combination goes on is thus proportional to n^2 where n is the number of ions of either sign present in unit volume of the gas. It can, therefore, be written αn^2 where α is a constant under given conditions and is known as the *coefficient of recombination*.

We have assumed that the numbers of positive and negative ions are equal. This is usually the case. If, however, for any cause they are different the rate of recombination by the same argument will be given by $\alpha n_1 n_2$, where n_1, n_2 are the number of positive and negative ions per c.c.

Ions are also withdrawn by the action of the electric field, and by diffusion to the electrodes or to the walls of the chamber. In general the effect of diffusion is small and may be neglected. In special circumstances it may become appreciable, and in these cases it can be measured.

Let us assume for a moment that there is no electric field across the gas and that the diffusion is negligible. Then the rate of increase in the number of ions per unit volume of the gas is equal to the number formed per second by the action of the ionizing agent less the number lost by recombination. Hence

$$\frac{dn}{dt} = q - \alpha n^2.$$

The ionization reaches a steady state when dn/dt is equal to zero or

$$q = \alpha n^2. \quad (2)$$

If the ionizing agent is then withdrawn q becomes zero, and the ionization in the gas decreases according to the equation

$$\frac{dn}{dt} = - \alpha n^2,$$

or
$$\frac{1}{n_0} - \frac{1}{n} = - \alpha t, \quad (3)$$

where n_0 is the value of the ionization at the moment when the agent was removed, and t the time which has elapsed.

12. **Motion of the ions under a uniform electric field.** If X is the strength of the electric field across the gas the force acting on any ion is equal to Xe . If the ion were perfectly free to move this would produce a constant acceleration of Xe/m where m is the mass of the ion. The ion is, however, moving through other uncharged gas molecules; its path therefore is made up of a series of short runs, each terminating in a collision in which all the accumulated energy of the ion is lost. Under these circumstances it is easy to shew that the ion will move not with a uniform acceleration but with a constant velocity which is proportional to the field applied.

For let λ be the mean free path of the ion in the gas, and τ the time taken by the ion to describe its mean free path under the action of the field. We may suppose that the whole of the velocity added by the field is removed at each collision and that the ion thus starts its course again with zero velocity. Between two collisions the ion moves freely under the action of the field. If X is the intensity of the field and e the charge on the ion, the mechanical force is Xe and the velocity v' of the ion on reaching the end of its path is therefore given by $Xe\tau = mv'$,

or
$$v' = \frac{Xe\tau}{m}.$$

The average velocity with which the ion describes its path is thus $\frac{1}{2}v'$, and if we assume that the time occupied by a collision is small compared with τ , this is also the mean velocity of the ion through the gas. The velocity of the ion is therefore given by

$$\frac{1}{2} \frac{Xe\tau}{m}, \quad \dots \dots \dots (4)$$

and is thus directly proportional to the applied field X , since e , m and τ are constants under given conditions.

Thus if u and v are the actual velocities of the positive and negative ions respectively in a field of strength X , we have

$$u = k_1X, \quad v = k_2X,$$

where k_1 and k_2 will be constants for a given gas under given conditions of temperature and pressure. They are known as the *mobilities of the ions*.

13. Theoretical relation between current and potential.

Let us now consider the current through the gas due to an applied potential difference V between the electrodes. Considering any plane in the gas normal to the direction of the field, then in one second all the positive ions which are situated at a distance of less than u cm. from it will be driven across the plane, while similarly all the negative ions distant less than v cm. from the plane will be driven across it in the opposite direction. The total transference of electricity across the plane in unit time will be the sum of the charges carried by the two sets of ions. If the magnitude of the charge e carried by an ion is the same for all ions the total transference is thus $ne(u + v)$ units per sq. cm. per sec. or if A is the area of the plane the total current across it will be

$$\begin{aligned} i &= Ane(u + v) \\ &= Ane(k_1 + k_2)X. (5) \end{aligned}$$

Now the passage of a current implies the withdrawal of a certain number of ions from the gas to the electrodes. The greater the current, the faster the ions will be removed, and hence the fewer will be the number of carriers left in the gas. Hence it is obvious that n , the number of ions present in unit volume of the gas, is a function of the current i . The problem is thus far from simple. We may however distinguish two limiting cases.

(1) *The current is so small that the number of ions withdrawn is negligible compared with the number present per c.c.* In this case the loss of ions is due solely to recombination and n is a constant, its value being given by (2).

If the electrodes are arranged so that the field is uniform, as for example in the case of two parallel plates, the field is equal to V/d , where V is the potential difference between the electrodes and d their distance apart. In this case equation (5) becomes

$$i = Ane(k_1 + k_2)X = Ane(k_1 + k_2)\frac{V}{d}, . . . (6)$$

where A is the area of either electrode. This equation is of the same form as that for conduction through an electrolyte, if n is a constant. Under these circumstances the current through

the gas obeys Ohm's law, and this case corresponds to the first straight portion of our experimental curve.

(2) *The field is so large that the ions are conveyed to the electrodes without appreciable recombination.*

If the field is large the velocities of the ions become so great that the number recombining in the small time taken to reach the electrodes becomes negligible. In this case it is obvious that all the ions formed in the gas by the ionizing agent will be conveyed to one or other of the electrodes. If B is the volume of the gas between the electrodes the number of ions formed per second is Bq and the total charge conveyed to either electrode in one second is therefore Bqe . This is the maximum current through the gas, and, provided that the voltage is sufficient to produce saturation, is obviously independent of the difference of potential between the plates. This case therefore corresponds to the saturation current through the gas. It will be seen that the saturation current should be directly proportional to the volume of the gas, a result which we have already found experimentally.

Since the time taken for the ions to reach the electrodes is proportional to the distance which they have to travel, that is, to the distance apart of the electrodes, while the field for a given potential difference is inversely proportional to the distance between the electrodes, it follows that the potential necessary to produce the saturation current through the gas is directly proportional to the square of the distance apart of the electrodes. It has also been shewn to be proportional to the square root of the intensity of ionization.

Since the saturation current is found to be proportional to the pressure, it follows that q , the rate of ionization for a given strength of the ionizing radiation, is directly proportional to the pressure; that is to say, the number of ions formed is proportional to the number of molecules present.

(3) *The general case* has been considered by Sir J. J. Thomson, who found that on certain assumptions the current through the gas could be represented by an expression of the form

$$V = Ai + Bi^2, \dots \dots \dots (7)$$

where A and B are complicated constants and V is the p.d. across the gas. This expression is found to express the intermediate portion of the experimental curve (Fig. 6) reasonably well. This part of the curve is of no practical importance except in the case of the currents through flames where the ionization is so intense that the maximum fields which we can apply are insufficient to produce saturation. We will therefore defer this case until the experimental results for flames have been described (p. 122).

CHAPTER III

THE PROPERTIES OF THE GASEOUS IONS

14. **Measurement of ionic mobilities.** The mobility of an ion is defined as its velocity in cm. per sec. under the action of an electric field of one volt per cm. Ionic mobilities may be measured in various ways, the most direct of which is that due to Rutherford.

Rutherford's method. Two large metal plates were placed parallel to each other and 16 cm. apart on insulating blocks.

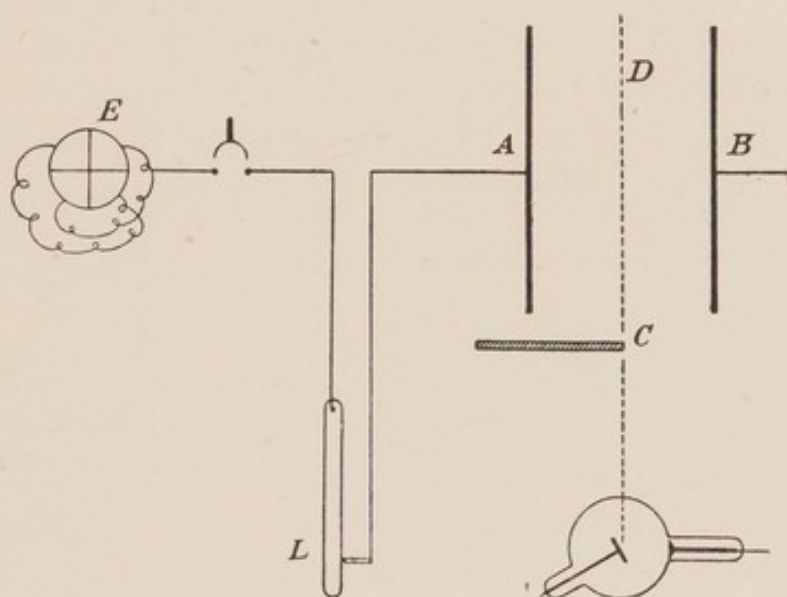

Fig. 7

One of these, *B*, was connected to a battery so that any suitable field could be applied across the gas, the other, *A*, was connected through an insulated lever to an electrometer *E*.

A heavy pendulum, not shown in the diagram (Fig. 7), was arranged so that at one point of its swing it made the circuit of the primary of an induction coil the secondary of which was connected to the X-ray tube used for ionizing the gas. Rays

were therefore generated and the gas became ionized. After a given interval (which could be calculated from the time of swing of the pendulum and the distance apart of the switches) the pendulum swung against the lever L and so disconnected the plate A from the electrometer.

Owing to the screen C only the portion of the gas to the right of the plane CD is ionized. Hence to reach A the ions must travel through a distance equal at least to that between A and the plane CD . Hence unless the time taken by the ions to travel this distance is less than the time which elapses between the switching on of the rays, and the breaking of the electrometer circuit at L , the electrometer will shew no charge. If the time is gradually increased a point is reached when the electrometer begins to shew a deflection, that is when the ions from CD are just able to reach the plate A before the connection at L is severed. This critical time is evidently the time taken for the ions to travel under the action of the field from CD to A . In Rutherford's experiment the critical time was 0.36 sec., when the potential of the plate B was 220 volts and the distance to be travelled was 8 cm. The velocity of the ion was therefore $8/0.36$ cm. per sec., with a potential gradient of $220/16$ volts per cm. The mobility of the ions was therefore $\frac{8}{0.36} \div \frac{220}{16}$ or about 1.6 cm. per sec. per volt per cm.

Langevin's method of measuring mobilities. Rutherford's method, though very direct, is not capable of great accuracy. It has been replaced by one due to Langevin. The gas, as before, is enclosed between two parallel plane electrodes and exposed to a suitable difference of potential, one of the electrodes being connected to a battery, the other to an electrometer.

In performing the experiment the connection with the battery is made and the *whole* of the gas between the plates is then ionized by a single instantaneous flash of X-rays from a powerful bulb. After some interval of time t from making the flash the direction of the field across the gas is reversed by reversing the potential of the charged electrode. The charge which has been received by the insulated plate is measured by the electrometer, and a curve is plotted shewing how this charge varies with the

interval t between the flash and the reversal of the field. This interval must, therefore, be variable and must also be capable of accurate measurement. In practice this can be effected by arranging that the various electric circuits are operated either by a pendulum, as in Rutherford's experiment, or more conveniently by a falling weight.

To simplify the problem we will assume that the times concerned are so short that we may neglect recombination. Let us assume that the charged plate is originally positive and that the strength of the field is X . As soon as the flash passes, ionizing the gas, positive ions begin to move towards the insulated plate with a velocity k_1X . Hence in the time t which elapses before the reversal of the field all the positive ions contained in a slab of gas of thickness k_1Xt cm. reach the insulated electrode and give up their charges to it. Hence if n is the number of ions per unit volume the total number of ions reaching the positive plate will be

$$N = nk_1XtA$$

where A is the area of the plate.

In the same time a number of negative ions equal to nk_2XtA will have been removed at the other electrode. The total number of negative ions left in the gas at the moment of reversal is therefore $(nAd - Ank_2Xt)$ where nAd is the total number of negative ions originally present in the gas. On reversing the field all these ions will eventually reach the insulated electrode.

The total *negative* charge communicated to this plate is the difference between the negative and the positive charges. Thus if e is the charge on each ion, the charge on the plate at the end of the experiment will be

$$\begin{aligned} Q &= e(nAd - Ank_2Xt) - e(nk_1XtA) \\ &= Ae \{nd - nX(k_1 + k_2)t\}. \quad \dots \quad (8) \end{aligned}$$

Hence starting with a very small value of t , the graph between Q and t will be a straight line, the negative charge decreasing, and finally giving place to a positive charge as t is increased.

Suppose now that the negative ions travel faster than the positive. As t is increased a stage will be reached when all the negative ions will reach the charged electrode, before the

field is reversed. If d is the distance between the plates this will obviously occur when $k_2 X t$ becomes equal to or greater than d . After this point is reached no negative ions will reach the insulated plate the positive charge on which will, therefore, be equal to

$$Q = Ae (nk_1 X t). \quad \dots \quad (9)$$

The relation will again be linear but the inclination with the axes will be altered. There will thus be a sharp kink in the curve at the point where the two lines meet, and this kink obviously occurs at the point where

$$t = \frac{d}{k_2 X}. \quad \dots \quad (10)$$

Since the velocity of the positive ions is less than that of the negative, there will still be positive ions between the plates

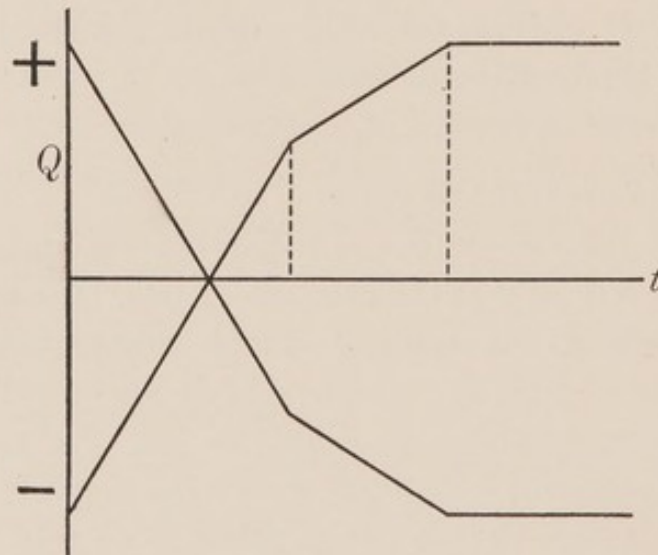

Fig. 8

when all the negative have been removed. If the reversal takes place before these have time to reach the insulated plate they will be carried back to the charged plate. Hence the charge on the insulated plate will still increase until the time between the flash and the reversal of the field is sufficiently long for all the positive ions to reach the insulated plate. This will occur when $k_1 X t$ is equal to d , or

$$t = \frac{d}{k_1 X}. \quad \dots \quad (11)$$

Since all the ions now reach the plate the total number reaching

the plate is simply equal to the number of positive ions formed by the rays, that is

$$Q = A nde$$

and is thus independent of the time.

The complete curve between Q and t should thus have the form shewn in Fig. 8, where the ordinates represent Q , and the abscissae the corresponding values of t . Since d and X are known, the times corresponding to the two kinks in the curve will give us the values of k_1 and k_2 .

Owing to want of uniformity in the ionization between the plates the experimental curves are not straight lines but have the form shewn in Fig. 9 which is taken from one of Langevin's

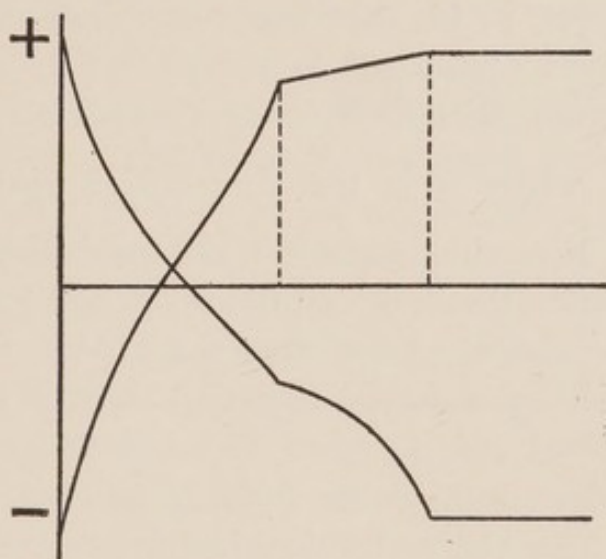

Fig. 9

papers. It will be seen that the kinks are very pronounced, and the mobilities can thus be deduced with considerable accuracy.

15. Mobilities of the ions in different gases. The following table (Table I) will give some idea of the mobilities of the positive and negative ions at ordinary temperatures and pressures. It will be noticed that for the lighter gases the negative ion has always a somewhat higher mobility than the positive. The difference becomes less as the molecular weight of the gas increases. It may be noted also that water vapour has in many cases a marked effect on the mobility of the ions, especially on the negative ions, the velocity of which it materially reduces. We shall return to these points later.

TABLE I

SUBSTANCE	$k_1 (+)$	$k_2 (-)$
Hydrogen	6.70	7.95
„ (moist)	5.30	5.60
Air	1.36	1.87
„ (moist)	1.36	1.51
Carbon monoxide	1.10	1.14
Carbon dioxide	.81	.85
Sulphur dioxide	.44	.41
Pentane	.35	.35

16. Approximate calculation of the mobility of an ion.

We have seen, (4), p. 19, that assuming that the ion retains none of the velocity produced in it by the field after collision with another atom, that its velocity through the gas is given

by $v = \frac{1}{2} \frac{Xe}{m} \tau$ where τ is the time which elapses between

two collisions. Now since the ion forms part of the gas it will participate in the thermal agitations of the gas molecules, and the kinetic theory shews that the kinetic energy of the ions for this motion must be equal to that of the molecules of the gas in which it is formed. This velocity will, therefore, vary as the square root of the mass of the ion. At ordinary temperatures these thermal velocities are very large. In the case of air for example the mean molecular speed at atmospheric pressure and 0° C. is 48,500 cm. per second. Since these velocities are distributed equally in all directions the number of ions carried by the thermal agitations across any plane in the gas in one direction will be equal to the number carried across it in the opposite direction, and hence the total transference of electric charge across the plane will be zero. Thus the thermal agitation causes no transference of electricity, and hence no current in the gas. We may, therefore, neglect it in considering the transference of electricity through the gas. On the other hand it will be the controlling factor in determining the number of collisions made by the ion. If λ is the mean free path of the ion in the gas, and V_1 the velocity of the ion, then τ the time occupied in describing the mean free path will be

equal to λ/V_1 . But since the velocity of the thermal agitation is very large compared with the velocity added by the field (which in the case of a field as great as 100 volts per cm. would only amount to about 160 cm. per sec.), the value of V_1 will be practically equal to V the velocity of the thermal agitation. Hence we have, on substituting for λ in (4),

$$v = \frac{1}{2} \frac{e}{m} \frac{\lambda}{V} X \quad . \quad . \quad . \quad . \quad . \quad . \quad (12)$$

or the mobility of the ion is equal to $\frac{1}{2} \frac{e}{m} \frac{\lambda}{V}$.

This formula should enable us to calculate the mobility of an ion if the size of the ions is known, or conversely to deduce the size of the ion from its mobility. If we assume that the ion formed in, say, oxygen is simply a charged molecule of the gas, then V is the ordinary velocity of the oxygen molecule, or 461 metres per second: the value of e/m for a hydrogen atom, as we shall see later (p. 50), is 10^4 e.m.u. per gm., and for the oxygen molecule therefore, assuming that all ions carry the same charge, it is $\frac{1}{3^{\frac{1}{2}}} \times 10^4 : \lambda$, the mean free path of an uncharged molecule of oxygen at normal temperature and pressure is 10^{-5} . Substituting these values we have the mobility in oxygen equal to 3.2×10^{-8} cm. per sec. per absolute e.m.u. of field or 3.2 cm. per sec. per volt per cm. since a volt is 10^8 absolute e.m.u. of potential.

This is rather more than twice the measured mobility of the positive ion in oxygen, and would indicate that the ion is somewhat larger, but not much larger, than the molecule. In all probability it is identical with it. The formula we have developed above overestimates the mobility for two reasons. In the first place our assumption that no time is lost during collision is possibly not accurately true. In the second case the mean free path of a charged ion will certainly be less than the mean free path of an uncharged molecule of the same size on account of the electric attraction between the charge on the ion and the uncharged molecules of the gas. Hence we are led to the conclusion that in a gas at normal pressures the gaseous ion consists of a single molecule of the gas bearing an electric charge.

17. Effect of pressure on the mobility of the ions.

The mobility of the ion is thus given by $\frac{1}{2} \frac{e \lambda}{m V}$. But the mean free path λ is, by the kinetic theory of gases, inversely proportional to the pressure p of the gas. Hence if the nature of the ion does not change the mobility k of the ion should be inversely proportional to the pressure of the gas, or the product pk should be constant.

The mobility of the ions at different pressures can easily be determined by Langevin's method, the gas being enclosed in an air-tight chamber. The results obtained are represented

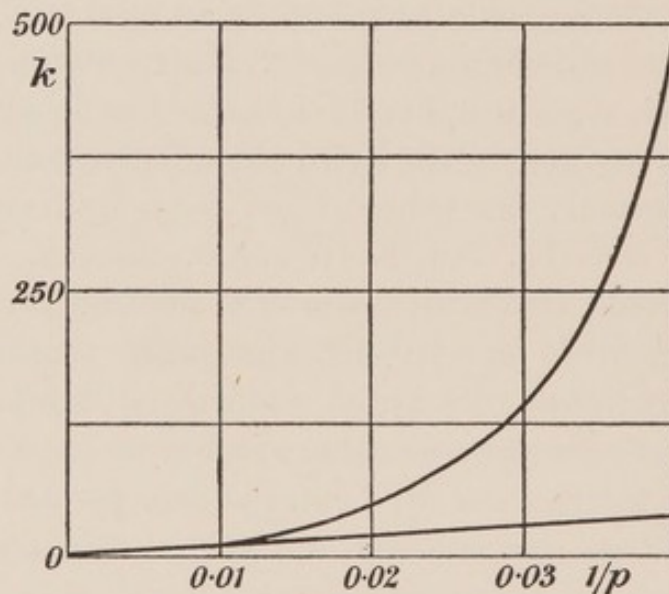

Fig. 10

by the curves in Fig. 10, where the lower curve, which is straight, refers to positive ions, and the upper one to the negative. It will be seen that the product pk_1 for the positive ions remains practically independent of the pressure down to the lowest pressures used. If the positive ion consisted of a cluster of molecules held together by the electric charge we should certainly expect the cluster to become smaller as the pressure was reduced. The fact that this is not the case is additional confirmation of the view that the positive ion consists of a single charged molecule. With the negative ions however at pressures less than about one-tenth of an atmosphere the product pk_2 increases rapidly as the pressure is reduced, thus indicating that the mobility of the negative ion is increasing

more rapidly than would be due merely to the alteration of the free path with pressure. In other words the negative ion is becoming smaller as the pressure is reduced. As the ion at atmospheric pressure consists of a single electron it is clear that at low pressures the negative carriers must be smaller than the molecule.

We have already seen (§ 1) that the atoms of all substances contain negatively charged particles, or electrons as they are usually called, of a mass equal to about $1/1800$ of that of a hydrogen atom, and that under certain circumstances these electrons may be ejected from the atom and appear in a free state. We must therefore regard the mechanism of gaseous ionization in the following way. The action of the ionizing agent brings about the expulsion of an electron from the molecule of the gas, leaving the latter with an excess of positive electrification. This positively charged molecule forms the positive ion. The negative electron is now, for a moment, in the free state, but being strongly charged it readily attaches itself to one of the neutral molecules by which it is surrounded, thus forming a negative ion of the same size as the positive.

It may be noted that whereas the positive ion is formed directly from a molecule, the negative carriers begin life in the form of an electron. Since the electron is very small its velocity under the action of an electric field will be very much larger in the free state than when attached to a molecule. Thus if the negative carriers pass any appreciable fraction of their time in the free state the velocity with which negative electricity passes across the gas will be materially increased, and thus the mobility of the negative ions which measures the average rate at which they are moving will be considerably increased. In many gases, such as air for example, the effect is quite appreciable even at ordinary pressures as shewn by the fact that the measured mobility of the negative ion is greater than that of the positive. As the pressure is reduced the time spent by the charge in the free state is considerably increased and the mobility becomes rapidly greater. Increase of temperature causes a similar effect on the mobility of the negative ion.

18. Measurement of the coefficient of recombination. The coefficient of recombination of the ions can be measured directly by a method due to Rutherford. A steady stream of gas is passed down a long tube (Fig. 11) at the entrance to which is placed a layer of uranium oxide. This supplies a constant source of ionizing rays so that the gas is all ionized to the same extent. At various points along the tube are placed electrodes which can be connected to an electrometer. These electrodes may conveniently take the form of thin rods of equal length parallel to the axis of the tube, while the tube itself, raised to a sufficiently high potential to produce the saturation current through the gas forms the other electrode.

The saturation current is measured successively at each of the electrodes. Since the electrodes are all equal and

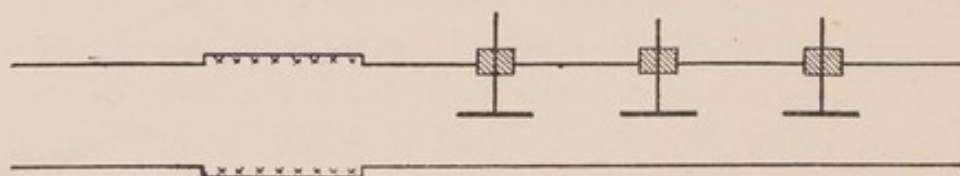

Fig. 11

similar the saturation currents will obviously be proportional to the number of ions present in the gas per unit volume, at the given electrode. If the distance apart of the electrodes is known, and the rate of flow of the gas along the tube, the time taken for the gas to flow from one electrode to the next can be calculated, and thus the number of ions left in the gas after various intervals of time is obtained. In this way Rutherford was able to verify experimentally the equation (3) for the rate of decay of ionization in the gas. In one of his experiments, for example, he found that the ionization amounted to as much as 10 per cent. of its maximum value as long as four seconds after removal from the ionizing rays, while in another experiment where the initial ionization was less intense the gas even after 16 seconds retained 10 per cent. of its initial conductivity.

This method though simple, and direct, is not capable of any great accuracy, and has been replaced by one due to Langevin, which however requires a knowledge of the mobilities of the ions under the conditions of the experiment. The gas

to be experimented upon is contained between two parallel plates, *A* and *B* (Fig. 12), and a layer *CD* of it parallel to the plates is ionized by a single powerful flash of Röntgen rays. An electric field is applied between the plates by connecting one of them to a suitable number of cells, the other being connected to an electrometer in the usual way.

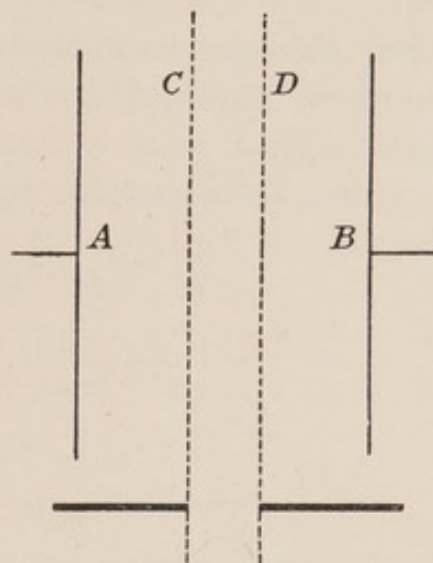

Fig. 12

The ions begin to move under the field towards the opposite plates. All recombination must occur within the ionized layer. As soon as the ion leaves this layer it is surrounded only by ions of its own sign, and therefore cannot recombine. It is obvious that the faster we can pull the ions out of the layer the smaller the recombination will be, and the larger the charge we shall collect on the insulated plate, *A*.

Suppose that after an interval *t* there are in the ionized layer *n* positive and *n* negative ions per unit volume. The positive ions are moving with a velocity k_1X and the negative with a velocity k_2X in the opposite direction. The walls of the slab are therefore approaching each other with a velocity $(k_1 + k_2)X$. Thus in a small time *dt* the thickness of the layer is reduced by $(k_1 + k_2) Xdt$ and the number of ions of each kind separated is

$$n (k_1 + k_2) Xdt.$$

Since the ions so separated are no longer liable to be lost by recombination, they will eventually reach the corresponding electrode giving to it a charge

$$dQ = en (k_1 + k_2) Xdt.$$

But

$$n = \frac{n_0}{1 + n_0at},$$

where n_0 is the number of ions of each kind originally present in unit volume;

$$\therefore dQ = \frac{(k_1 + k_2) n_0 e X dt}{1 + n_0 a t} \dots \dots \dots (13)$$

The number of recombinations occurring between oppositely charged ions in oxygen as determined above is $1.6 \times 10^{-6} n^2$. The number of collisions producing recombinations between the ions is thus about 10,000 times the total number of collisions which would occur in the same time between uncharged molecules of the gas. This must be due to the strong electrical attraction between the oppositely charged ions, which draws them together when otherwise they would never have met.

CHAPTER IV

THE CHARGE ON AN ION

19. **Condensation of water drops on ions.** By applying a saturation voltage across a gas we can, as we have seen, sweep all the ions in the gas to one or other of the electrodes. The charge given to either electrode is then equal to the sum of the charges on all the ions of one sign present in the gas, that is, to ne where n is the total number of ions of either sign, and e the charge carried by each. To determine e it is necessary to find some method of counting the number of ions present in the gas.

A method of doing this was afforded by the discovery of C. T. R. Wilson that charged ions can serve as nuclei for the condensation of water vapour. It had long been known from the researches of Aitken that the water drops which form when a space becomes supersaturated with water vapour always collect about dust particles or similar nuclei present in the gas. If all nuclei are removed (either by filtration through cotton wool or better still by repeatedly forming clouds in the same closed space and allowing the drops so formed to settle, thus carrying the nuclei with them), a very considerable degree of supersaturation may exist in the gas without the separation of any drops. If, however, the pressure of the aqueous vapour in the gas exceeds about eight times its saturation pressure for the temperature of the experiment a fine drizzle sets in even in the absence of all nuclei.

Wilson shewed that if the gas was ionized deposition could take place in the absence of other nuclei, the ions themselves serving as nuclei about which the drops could form. It was found that deposition would take place on negative ions when the pressure of the aqueous vapour was four times the saturation value, and on the positive ions when it reached about six times that amount.

These effects are due to surface tension. It can be shewn that the vapour pressure over a convex surface of liquid is greater than that over a plane surface by $\frac{\sigma}{\rho - \sigma} \frac{2T}{r}$ where σ is the density of the vapour, ρ that of the liquid, T the surface tension, and r the radius of curvature of the surface. If r becomes indefinitely small as would be the case for a drop starting from zero dimensions this excess of pressure would be infinite, and the drop would immediately evaporate. The nuclei, by providing surfaces of finite radius of curvature on which to condense, enable the drops to commence at a finite size, and hence to grow to visible dimensions even with a comparatively small degree of supersaturation. The drizzle which sets in when the supersaturation is eight-fold is probably due to deposition round molecules of vapour or gas.

The effect of giving a charge to the drop can most easily be discussed from the considerations of potential energy. The potential energy of a drop due to its surface tension is equal to its area multiplied by the surface tension, that is to $4\pi r^2 T$, and becomes smaller as the radius is decreased. Hence surface tension will tend to reduce the size of the drop, that is, to assist evaporation, since any system tends to reduce its potential energy to a minimum. On the other hand the potential energy of a drop due to a charge e upon it is $\frac{1}{2} \frac{e^2}{r}$. This increases as r becomes smaller, and hence the effect of the charge is to tend to increase the size of the drop. The electric charge therefore acts in the opposite sense to the surface tension, and may be regarded as producing a diminution in it. Thus a charged drop will grow under conditions under which an uncharged drop of the same radius would evaporate. It is obvious, therefore, that a drop will be formed around a charged molecule, or ion, with a smaller degree of supersaturation than that required when the molecule is uncharged.

20. C. T. R. Wilson's cloud experiments. The method adopted for producing supersaturation in the air is based on the cooling of a gas by adiabatic expansion. The apparatus used

is shewn in Fig. 13. The gas in the expansion chamber is shut in by a movable piston *P*, which is made as light as possible so as to move with ease and rapidity. The joint is made air-tight with water *W*, which also serves to keep the space saturated with moisture. The air space inside the hollow piston communicates by means of a wide tube *T* with the barrel *B*, and the piston can be raised to any required position in the outer glass cylinder *D* by forcing a little air in through the tap

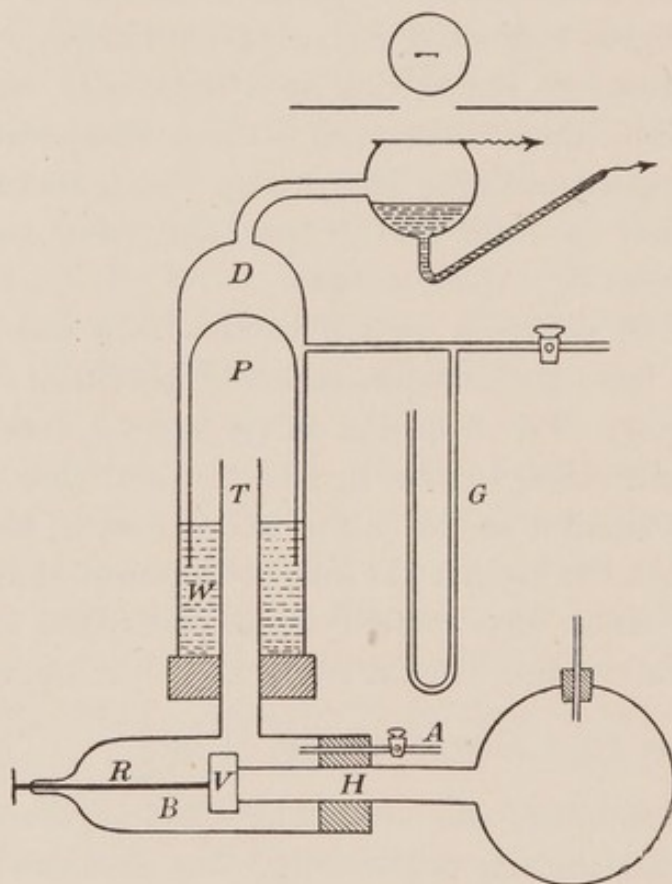

Fig. 13

A. Thus by suitably adjusting the initial position of the piston an expansion of any desired amount can be made.

The expansion is made as follows. A wide tube *H* connects *B* with a large vessel of several litres capacity which is kept at a low pressure by the continuous action of a water pump. *H* is normally closed by a valve *V*, but by smartly pulling back the rod *R* the valve is opened allowing the space beneath the piston to be exhausted very quickly through the tubes *T* and *H*. The pressure below *P* being thus reduced, it falls with

great rapidity, producing a nearly instantaneous expansion of the gas in the expansion chamber.

The actual expansion can easily be deduced by reading the pressure gauge G before and after the experiment. Let π be the atmospheric pressure and p_1 the difference of pressure in the two arms of the gauge before expansion. Then P_1 the initial pressure of the gas in the chamber is $(\pi - p_1 - \sigma)$ where σ is the saturation pressure of aqueous vapour at the temperature of the experiment. The final pressure of the gas after the apparatus has again attained the temperature of the laboratory is $(\pi - p_2 - \sigma)$ where p_2 is the new reading of the gauge. Hence by Boyle's law

$$\frac{v_2}{v_1} = \frac{\pi - p_1 - \sigma}{\pi - p_2 - \sigma},$$

which gives the expansion.

Since the expansion of the gas is adiabatic, $\theta v^{\gamma-1}$ is a constant and

$$v_1^{\gamma-1} \theta_1 = v_2^{\gamma-1} \theta_2,$$

$$\log_e \frac{\theta_1}{\theta_2} = (\gamma - 1) \log_e \frac{v_2}{v_1} \quad \dots \dots \dots (17)$$

which gives θ_2 since γ is known. The values of the saturation pressure of aqueous vapour at the temperatures θ_1 and θ_2 can be ascertained from tables and hence the degree of supersaturation produced in the space by the expansion can be obtained.

Working with this apparatus Wilson found that, after freeing the chamber from dust nuclei no cloud was formed for values of v_2/v_1 less than 1.375, which was the expansion necessary to produce eight-fold supersaturation. If, however, the gas was previously ionized by passing X-rays into it through an aluminium window, a dense cloud appeared when the expansion exceeded 1.26, shewing that fresh nuclei are formed in the gas by the action of the rays. If these nuclei are gaseous ions they should be removable by the action of an electric field. This was found to be the case.

The effect of each kind of ion separately was investigated with a cloud chamber of the form shewn in Fig. 14. The chamber was divided by a central metal partition C which was earthed

and the two electrodes were charged positively and negatively respectively. The gas was ionized by a narrow pencil of rays close to each side of *C*. By the action of the two fields the positive ions in *A* and the negative in *B* were driven into the plate *C* so that all the ions in *A* were negative, and those in

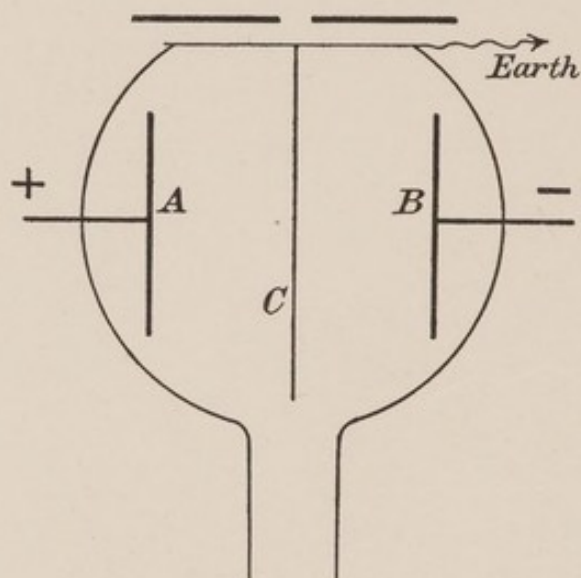

Fig. 14

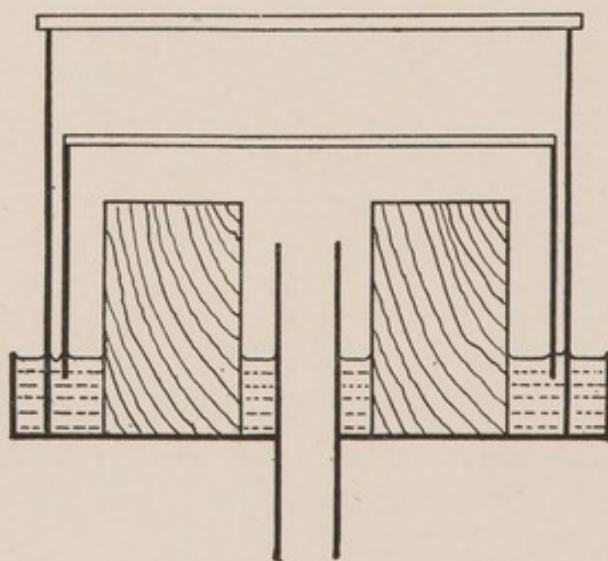
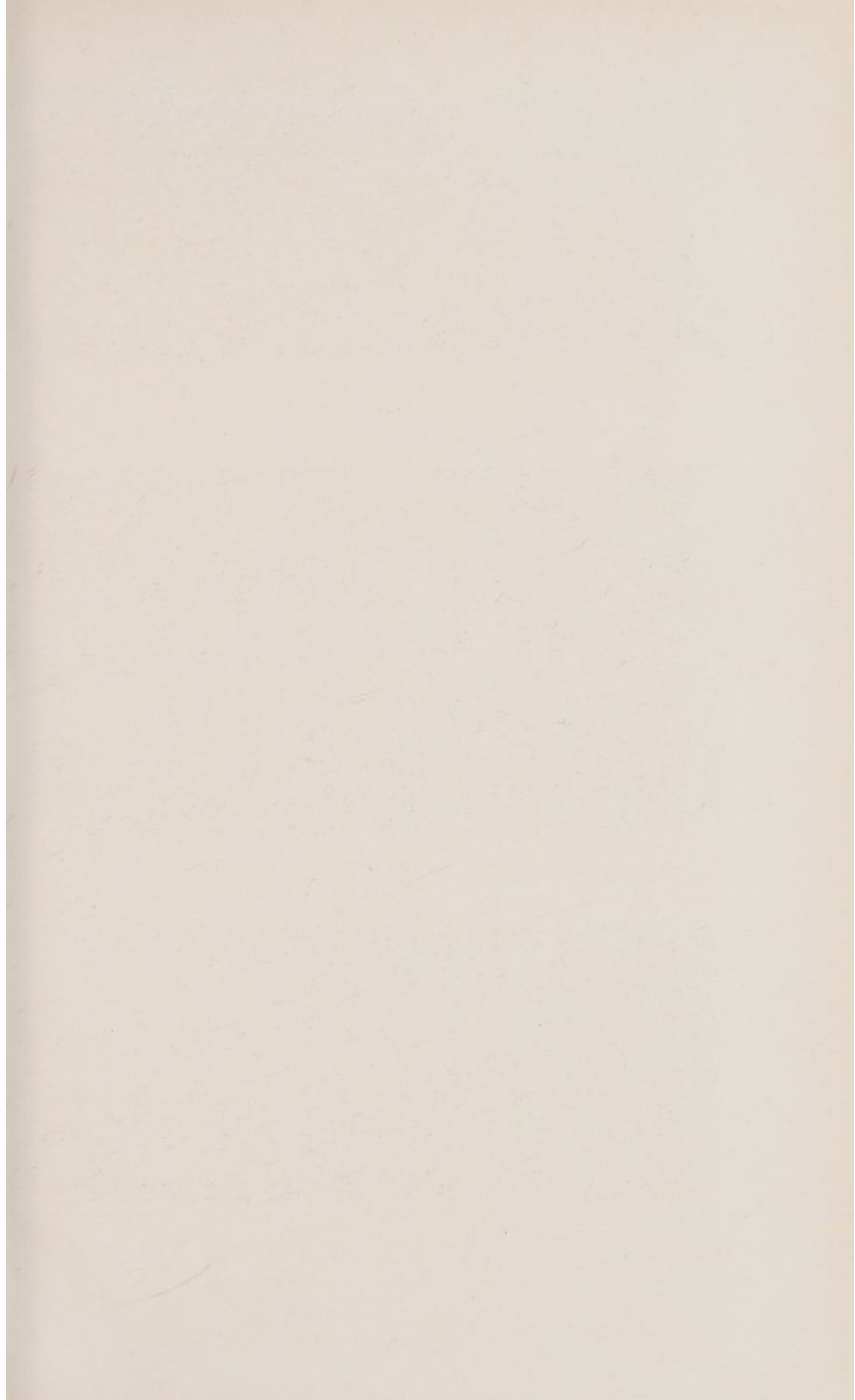

Fig. 15

B positive. On making an expansion it was found that a cloud was formed as before on the negative ions when the expansion reached 1.26, but that no cloud appeared on the positive ions in *B* until the expansion reached 1.30, corresponding to a six-fold supersaturation. The negative ions are thus more efficient in condensing drops of water than the positive.



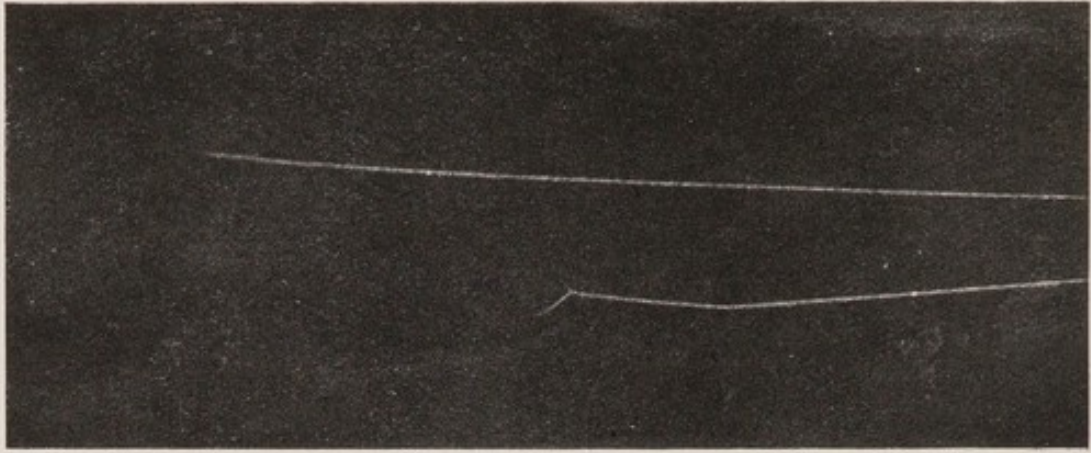

Fig. 16



Fig. 17



Fig. 18

[To face page 41

21. C. T. R. Wilson's later condensation experiments.

In the form of cloud chamber originally used the gas expanded through a side tube, and air currents were thus set up in the chamber. By modifying the apparatus so that the piston formed the floor of the cloud chamber itself (Fig. 15) it was found possible to produce expansion while leaving the gas perfectly at rest. The expansion arrangements were otherwise unaltered. By allowing one or two ionizing particles to enter the chamber and producing a simultaneous expansion in the air the track of the particle through the chamber was rendered visible by the drops formed round the ions produced along its path. Fig. 16 shews a photograph of the tracks made by α -particles from radium. The ionization caused by the α -particles is so intense that the drops coalesce into a single continuous streak. Fig. 17 in the same plate shews the track left by a single β -particle. Here the ions formed per cm. are far less numerous than in the case of the α -particle and the individual ions can be clearly seen. Fig. 18 is a photograph of the track left by a beam of X-rays passing from left to right. We shall refer to this later. The method is likely to prove of great importance in the study of the properties of ionizing radiations.

22. Application of the condensation experiments to the determination of e . Thomson's method. Suppose a cloud is formed in a cloud chamber of the form in Fig. 13, the expansion being arranged so that the drops condense only on the negative ions in the gas. These ions may be produced by any convenient ionizing agent. Let W_1 be the weight of water vapour required to saturate the space inside the chamber completely at the initial temperature, and W_2 that required to saturate it at the lowest temperature reached during expansion. Then the weight of water deposited is given by $M = W_1 - W_2$, and is known since W_1 and W_2 can be calculated from the volume of the chamber and the densities of the saturated vapour at the two temperatures. It may be assumed that, providing that drops are formed, the whole of the vapour over and above that required to saturate the space will be deposited.

The small drops making up the cloud will fall under the action

of gravity with a uniform limiting velocity given by Stokes' law. Thus if r is the radius of the drop, η the viscosity of air, ρ the density of water, and g the acceleration due to gravity, the drops will fall with a uniform velocity given by

$$v = \frac{2}{9} \frac{g\rho r^2}{\eta} \dots \dots \dots (18)$$

This velocity can be measured by observing the rate at which the surface of the cloud settles down by means of a cathetometer or reading microscope. Since all the constants are known the observed value of v will enable us to calculate the radius r of a single drop. It is found that the drops are all the same size, as can be seen from the fact that the cloud settles down as a whole without separating into layers. The mass of each drop is therefore $\frac{4}{3}\pi r^3\rho$ and if n is the total number of drops in the cloud

$$\frac{4}{3}\pi r^3\rho n = M \dots \dots \dots (19)$$

which gives us n since M the mass of the cloud is known.

If the water surface is connected to an electrometer the quantity Q of electricity brought down by the cloud can be measured. The charge on a single ion is then equal to $\frac{Q}{n}$.

Balancing method of determining e . The previous method was first carried out by Sir J. J. Thomson. An interesting modification is due to H. A. Wilson. In this the clouds were formed and the radius of the drops determined by the application of Stokes' law as in the previous experiment. An electric field, X , was then applied across the chamber so as to attract the drops towards an upper plate which was positively charged, the lower surface being earthed. The electric force Xe acting on the drops was thus in the opposite direction to that of gravity, and by suitably adjusting the strength of the field the two forces could be made to neutralize each other exactly so that the cloud remained stationary in the chamber, suspended in air "like Mahomet's coffin." When this state is reached we have

$$Xe = mg \dots \dots \dots (20)$$

where X is the electric field and m the mass of the drop. But m can be calculated, as before, from the velocity of the free

fall under gravity and hence e can be obtained. Assuming that each drop forms round a single ion this is the charge on the ion.

Both these experiments are subject to a serious error. The gas after expansion begins to warm up again by conduction and radiation from the room, and consequently the space around the drops soon ceases to be saturated. Hence the drops begin to evaporate and their mass m is constantly decreasing during the course of the experiment. This defect has been overcome by a method due to Millikan.

23. Millikan's experimental determination of e . The question has been investigated very fully by Millikan using a

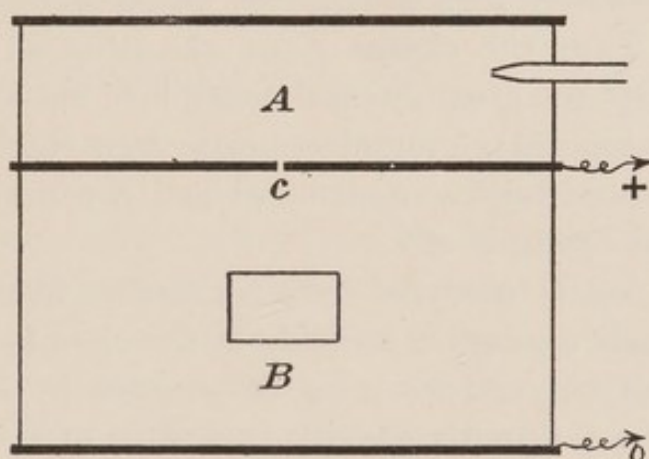

Fig. 19

method similar to that of Wilson but free from the uncertainties caused by evaporation. Instead of condensing drops of liquid on the ions Millikan forms his drops mechanically by some form of sprayer in an atmosphere saturated with the liquid, and leaves them to acquire charges from the ionized air by collision with the ions. His apparatus is shown in Fig. 19.

A little of the liquid under experiment, generally oil or mercury, was sprayed into the upper chamber A , and a few drops fell through a small hole c into the experimental chamber B . The upper and lower plates bounding this chamber were insulated and could be charged to varying differences of potential by a battery of small cells, so that any required vertical field could be applied across the gas, or by

connecting the plates together the field could be removed and the drop allowed to fall freely under gravity. Its radius could thus be deduced from Stokes' law, and knowing its density the mass m could be calculated. The drops shewed little tendency to evaporate and the mass m remained appreciably constant over long intervals. By adjusting the field the drops could be made to remain stationary and a single individual drop could thus be kept under continuous observation for several hours.

Now the drops are not initially charged but if the air is ionized they become so by collision with the charged ions. Since the diameter of the drop is large compared with that of an ion, its potential rises comparatively slowly, and it may accumulate several charges of the same sign before its potential becomes sufficiently high to prevent other like charges from reaching it. Thus the charge E on the drop at any instant may be any not too great integral multiple of the ionic charge e . On the other hand if an ion of opposite sign reaches the drop part of its charge will be neutralized and E will be diminished again by some multiple of e .

The drops can be observed by a microscope focused on them through a small window in the side of the chamber B . A drop is now singled out and its mass determined by observing its velocity of free fall under gravity by means of a vertical scale in the eye-piece of the microscope. A field is then applied and adjusted until the drop remains stationary. The charge on the drop can then be calculated from the strength of the field. If the drop is kept under observation it will be found that sooner or later the stationary balance is destroyed and the drop either darts upwards, shewing that it has acquired an additional charge of like sign, or begins to fall shewing that part of its charge has been neutralized. The field is adjusted again until a fresh balance is obtained and the new value of the charge E is calculated. If all ionic charges have the same magnitude, each of the charges so determined must be some not too large multiple of the ionic charge. The greatest common factor of all the observed values is thus the minimum ionic charge.

A very large number of charges were thus measured by

Millikan using drops of various sizes and various liquids, and also with different ionizing agents. In every case the charge was found to be a multiple of the number 4.774×10^{-10} e.s.u. to a very considerable degree of exactness.

In order to ensure the greatest accuracy possible various subsidiary experiments were made. For example, a fresh determination of the viscosity of air was made, an error of 2 per cent. being found in the generally accepted value. Experiments were also made to test the applicability of Stokes' law in the case of the drops used, and a small correcting factor was found to be necessary, and its magnitude determined. This correction has since been shewn to be required by a more rigorous mathematical analysis of the case of falling drops. Millikan claims that his result is not in error by more than one part in 1000.

These results of Millikan bring out very clearly the fact that electricity like matter is not indefinitely divisible but consists of units or "atoms" which cannot be further subdivided. In every case, no matter what was the ionizing agent used to produce the charges, no matter what the gas in which they were produced, or the nature of the drops on which they were measured, the observed charge was invariably a multiple of the value 4.774×10^{-10} , no fraction of this amount ever being observed. On the explanation given of ionization this charge is that carried by an electron if negative or due to the absence of an electron if positive. The electron, therefore, constitutes an atom of electricity. We shall, therefore, refer to this charge as the *electronic charge*, and denote it by the letter e . Millikan's experiments shew, and many other observations confirm it, that the charge carried by all electrons is the same. It is a real universal constant. In nearly every case observed it was found that when charges were gained or lost by the drop, owing to collision with a gaseous ion, the magnitude of the charge so interchanged was the single electronic charge e . The cases in which the increase or decrease in the charge on the drop was a multiple of this value were only a minute fraction of the whole, and in Millikan's opinion might have been due to the simultaneous collision of two separate ions with the drop. Thus it

appears that, in general, a gaseous ion carries only a single electronic charge e ; as we have previously assumed.

24. Perrin's determination of e from the Brownian movement. When a current is passed through a solution of an electrolyte, the mass of the substance deposited on either electrode is proportional to the quantity of electricity which has passed. Thus the mass of hydrogen liberated by the passage of unit electromagnetic quantity of electricity is 1.04×10^{-4} gm. (the electrochemical equivalent of hydrogen); in other words one gram of hydrogen is in electrolysis associated with $\frac{1}{1.04 \times 10^{-4}}$ or $.96 \times 10^4$ e.m.u. of charge. It is assumed that the ions in electrolysis are atoms of the substance carrying a charge E which is the same for all monovalent ions. Thus, if n is the number of atoms in one gram of hydrogen, and E the charge on each in solution in e.m.u., the total charge carried by one gram of hydrogen will be nE , which must equal the value $.96 \times 10^4$ as determined above. Since there are two atoms of hydrogen in a molecule, and a gram-molecule of hydrogen weighs 2 gm., we can also write this result in the form

$$NE = .96 \times 10^4$$

where N is now the number of molecules in a gram-molecule of gas, an important number known as Avogadro's constant. If we can determine N we can calculate E .

An accurate method of determining N is afforded by Perrin's experiments on the Brownian movement.

Suppose a small particle, not too small to be visible with a powerful microscope yet not too large in comparison with the size of the molecules to be affected by collision with them, is suspended in water. This particle will, by the kinetic theory, be bombarded on all sides by the molecules of the water moving under their velocities of thermal agitation. On an average the number striking the particle will be the same in all directions and the average momentum communicated to the particle in any direction will be zero. Since, however, the collisions are governed by the law of probability there will, if the interval

of time considered be sufficiently small, be an excess of momentum in one direction or the other, and if the mass of the particle is not too large compared with the masses of the colliding molecules it will be given an irregular kind of motion which may be observed under a microscope.

This motion has been known for many years as the Brownian movement and is always to be observed in suspensions of fine particles in a liquid.

Experiments have shewn that the Brownian movements are independent of any currents in the liquid, or of any external vibrations. They occur with particles of any nature providing that the size is suitable, and they do not diminish with lapse of time. For example, Brownian movements can be observed among the fine particles enclosed in those liquid cavities which are often found in specimens of quartz and which have been sealed up for many millions of years. The explanation just given is the only one consistent with all these facts.

The particles in Brownian movement are thus sharing the thermal agitations of the molecules of the surrounding liquid in exactly the same way that the molecules of a heavy vapour share the motion of the molecules of a light gas in which they may be placed. In other words, from the point of view of the kinetic theory the particles in a suspension behave like the molecules of a dilute gas of very heavy molecular weight, each particle functioning as a single molecule. We can, therefore, apply the gas laws to them, and from observations on these visible particles determine the various unknown constants in the gas equations.

Distribution of the particles in a suspension in a vertical direction when in equilibrium under gravity. The most direct method of applying this result is to determine the way in which the particles of a suspension distribute themselves under the action of gravity. The case is similar to that of a gas under gravity.

Consider two horizontal planes separated by a distance dh in a vertical column of gas of unit cross section. If p and $p + dp$ are the pressures at the two planes, the difference dp

is equal to the weight of the gas enclosed between the two planes, since the cross section is unity. Hence if ρ is the density of the gas

$$\begin{aligned} dp &= mg = \rho g \cdot dh \\ &= \frac{M}{V} g \cdot dh \end{aligned}$$

where M is the molecular weight of the gas in grams and V is the volume of one gram-molecule. But $V = RT/p$ where T is the absolute temperature and R is the gas constant. Thus

$$\begin{aligned} dp &= \frac{Mgp}{RT} dh, \\ \therefore \log_e \frac{p_0}{p} &= \frac{Mg}{RT} H. \quad . \quad . \quad . \quad . \quad . \quad (21) \end{aligned}$$

where H is the vertical distance between the two points in the vertical column where the pressures are p_0 and p .

But the pressure is directly proportional to the number of molecules per c.c. in the gas. Hence we may write (21) in the form

$$\log_e \frac{n_0}{n} = \frac{MgH}{RT} \quad . \quad . \quad . \quad . \quad . \quad (22)$$

which gives the distribution of the molecules in a vertical column of the gas.

We can now apply this result to the case of the suspension. In this case if m is the mass of a single particle the "molecular weight in grams" will be equal to mN where N is the number of molecules in one gram-molecule of a gas, which by hypothesis is the same for all gases. The apparent mass of a particle suspended in a liquid is, however, less than its true mass m by the weight of the liquid it displaces; that is, it will be equal to

$$m \left(\frac{D-d}{D} \right),$$

where D is the density of the particle and d that of the liquid. Hence substituting in equation (22), we have

$$\log_e \frac{n_0}{n} = \frac{Nm}{RT} \left(1 - \frac{d}{D} \right) gH. \quad . \quad . \quad . \quad . \quad (23)$$

If the mass of the particles and their density are known a determination of the ratio of n_0/n for different depths will enable us to calculate N , the constant of Avogadro.

A suitable emulsion was found in gamboge, the particles being obtained of uniform size by centrifugal fractionation. The density could be determined by finding some solution in which the particles would remain suspended without falling, while the volume could be determined either by direct measurement of the radius of the particle or by calculating the latter from its rate of fall under gravity by Stokes' law.

To find the vertical distribution of the particles when in equilibrium a small drop of the emulsion was placed in a hollow cut out in a microscope slide (Fig. 20) and covered with a thin cover slip to prevent evaporation. A high power microscope was then focused on some definite layer of the emulsion and the field of view

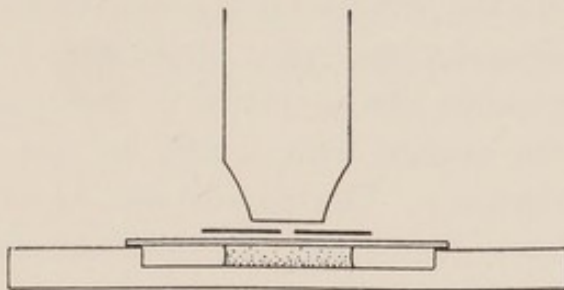

Fig. 20

limited by a stop so that not more than five or six grains were in the field of view at the same instant. Owing to the Brownian movement the particles are constantly appearing and disappearing but if not more than five or six are visible at the same time a practised eye can immediately grasp the number present at any given moment. Readings were made at equal short intervals of time, and the average number present in view is taken as proportional to n for that layer. Thus for some particular layer A in one set of experiments the numbers visible at ten successive moments were

2, 2, 0, 3, 2, 2, 5, 3, 1, 2,

giving an average of 2.2. At some higher level B the first ten readings were

2, 1, 0, 0, 1, 1, 3, 1, 0, 0,

giving an average of 0.9. The ratio n_1/n_2 for these two layers was therefore 2.2/0.9. In this way the average number of particles occurring at different depths in the liquid was deter-

mined and was found to agree very closely with the theoretical distribution, as calculated above. Substituting the experimental values in equation (23) N was found to be 68.2×10^{22} . A second method based on the distribution after a definite interval of time in a horizontal plane of a number of particles introduced at a given point in the liquid gave a mean value of $N = 68.8 \times 10^{22}$. Substituting these results in the equation $NE = .96 \times 10^4$ we find that the value of E the charge on a hydrogen ion in electrolysis is equal to 1.40×10^{-20} e.m.u. of charge or 4.2×10^{-10} e.s.u.

25. **Summary of results.** The value obtained by Perrin for the charge on a monovalent ion in solution is sufficiently close to the value obtained by Millikan for the charge on a gaseous ion to make it reasonably certain that in each case the charge with which we are dealing is the unit electronic charge e . The agreement, however, is not as close as might have been expected. Millikan claims an accuracy of one part in 1000 for his own experiments, and Perrin considers that the error in his cannot be more than 3 per cent. On the other hand the difference between the two values is nearly 15 per cent. Perrin believes that the correction applied to Stokes' law in Millikan's experiments was insufficient, and that consequently the mass of his drops was wrongly estimated. On the other hand Millikan's result is in close agreement with the values of e obtained by experiments on the α -particle (§ 98) and with that deduced by Planck from the theory of reduction. The various results are given in Table II. In the present volume we shall assume, as a provisional value,

$$\begin{aligned} e &= 4.7 \times 10^{-10} \text{ e.s.u.} \\ &= 1.57 \times 10^{-20} \text{ e.m.u.} \end{aligned}$$

Assuming this value for e the value of Avogadro's constant becomes 61×10^{22} molecules per gm. molecule. Since the ratio of the mass to the charge for a hydrogen ion in solution (i.e. the electrochemical equivalent of hydrogen) is 1.04×10^{-4} e.m.u. per gm., the mass of a hydrogen ion in electrolysis is $(1.04 \times 10^{-4}) \times (1.57 \times 10^{-20})$ or 1.64×10^{-24} gm. If the electro-

TABLE II

The charge on an electron

OBSERVER	METHOD	e in e.s.u.
Begeman	Water drops (original method of Thomson)	4.67×10^{-10}
Millikan	Oil and mercury drops	4.774×10^{-10}
Perrin	Brownian movements	4.2×10^{-10}
Rutherford	Charge on α -particle	4.65×10^{-10}
Regener	" "	4.79×10^{-10}
Planck	Theory of radiation	4.69×10^{-10}

lytic ion is an atom of the substance, as is generally assumed, this is the actual mass of a hydrogen atom. The masses of other atoms can be obtained by multiplying this number by the corresponding atomic weight.

CHAPTER V

IONIZATION BY COLLISION. THE SPARK DISCHARGE

26. **Ionization currents with large voltages.** We have already seen (§ 9) that the current through an ionized gas increases with increasing electric field up to a certain maximum value known as the saturation current. There is then a considerable range of electric fields greater than this saturation value for which increasing the field produces no appreciable increase in the current. It is found, however, that if the field is increased above a certain value the current again begins to increase,

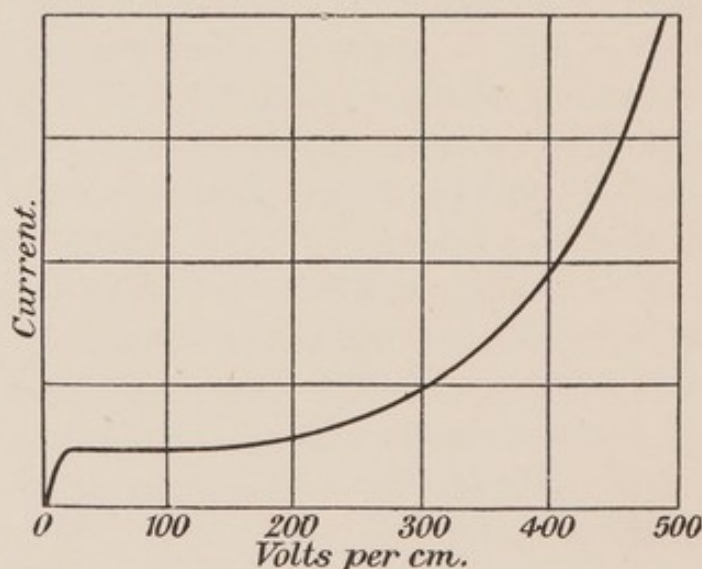

Fig. 21

at first slowly but soon with great rapidity (Fig. 21) until finally a spark passes between the electrodes, accompanied by a temporary but very considerable current. The field X required to produce an appreciable increase in the current above its saturation value depends on the distance apart of the electrodes, and on the nature and pressure of the gas. For air at ordinary pressures, and with distances of half a centimetre or more between the electrodes it is very large. It diminishes, however, as the pressure of the gas is reduced, and the phenomena are

most conveniently investigated in the case of gases at the comparatively low pressures of from one to ten millimetres of mercury. With such pressures it is possible to produce a considerable increase in the current through the gas with potential differences of not more than 50 volts.

The effect is to be ascribed to collision between the ions generated in the gas and the molecules of the gas. We have already shewn (§ 16) that the velocity acquired by an ion of mass m and charge e moving under the action of a field of strength X between two successive collisions is

$$\frac{Xe \lambda}{m V}$$

where λ is the length of the free path of the ion. Its velocity, on striking another molecule of the gas, is thus, for a given field, proportional to its free path.

The mechanism of ionization is a little obscure. Since however it involves the complete separation of a negative from a positive charge it is obvious that work must be done on the molecule so ionized, and the energy for this must be supplied by the source of ionization. In what follows we assume that this energy is supplied by the kinetic energy of the colliding particle. The kinetic energy of this particle must, therefore, reach a certain minimum value if fresh ions are to be produced by it in the gas by the process of collision.

The mean free path of a particle in a gas can be calculated from the kinetic theory of gases. The same theory, however, shews that in a considerable number of cases collision will not occur until the particle has described a free path considerably longer than the mean, while in others collision takes place before the mean free path has been described. Thus it can be shewn that in 14 per cent. of the total number of collisions, collision will not occur until the particle has described a path at least twice as great as the mean, while in 10 per cent. of the cases it takes place before one-tenth of the mean path has been completed. Thus assuming that the particle must describe a path λ before it has sufficient kinetic energy to produce fresh ions, ionization by collision will commence long before the mean

path of the ions has reached this critical value, and will not be complete until the conditions in the gas correspond to a mean free path considerably greater than the critical value.

27. Difference in the effects produced by positive and negative ions. It is found by experiment that the negative ion is much more efficient in producing ionization by collision than the positive ion, and begins to do so for much smaller values of the field. Consequently under ordinary circumstances the increase in the current across a gas caused by increasing the field above the critical value is due almost entirely to the ionizing action of the negative ions. Since the mean free path of a particle is inversely proportional to the pressure of the

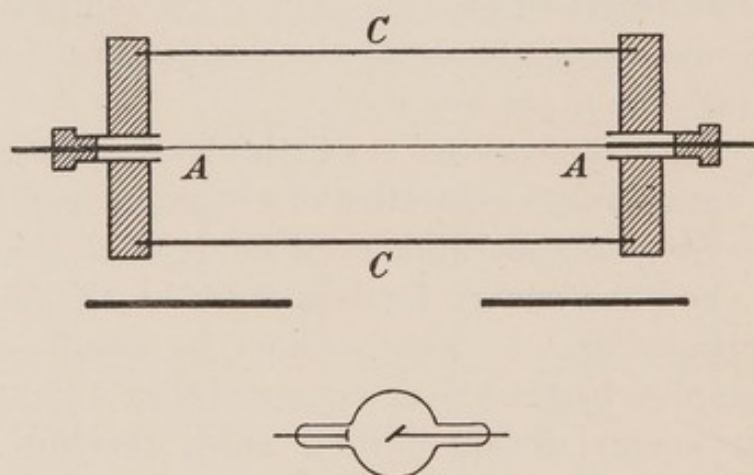

Fig. 22

gas the critical ionizing velocity is much more readily attained at low pressures than at high, and experiments on ionization by collision are most conveniently performed at pressures of the order of a few millimetres of mercury. At these pressures as we have seen the negative ion is identical with the electron, and has a much greater mobility than its positive partner. It is to this greater mobility that its superior efficiency is to be ascribed.

The difference in ionizing power can easily be demonstrated by experiments in which the field between the electrodes is not uniform but variable, as for example in the case where the field is set up between a central thin wire *A* and a coaxial cylinder *C* (Fig. 22). The field in this case is inversely propor-

tional to the distance from the axis, and is thus intense near the wire and very small near the cylinder. If air at ordinary pressures is enclosed in the cylinder, the saturation current is obtained with a difference of potential of a few hundred volts, and is independent of the direction of the field. It may be pointed out that owing to the want of uniformity of the field a much higher difference of potential is required to produce saturation in cylindrical ionization chambers of this kind than in those having parallel plate electrodes.

At low pressures a different state of affairs prevails. If X-rays are used as the ionizing agent it is known that the bulk of the ionization at low pressures is due to electrons emitted by the metal cylinder. The ionization produced in the gas by the

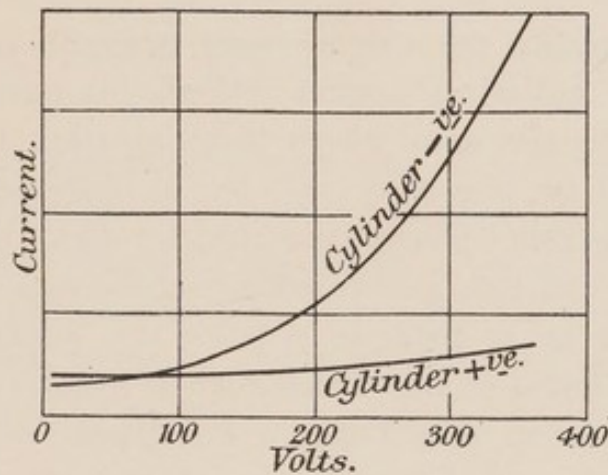

Fig. 23

direct action of the rays decreases proportionately to the pressure, while the number of electrons produced from the wire is small owing to its small surface. We may, therefore, regard the ionization as practically confined to the space near the walls of the outer cylinder.

If now the outer cylinder is positively charged the negative ions will be attracted to the cylinder and reach it after passing through a very small distance of air. The positive ions will be driven across the vessel to the wire.

If the field is reversed the opposite will be the case, the positive ions being withdrawn, and the negative driven across the chamber.

Since the velocity in collision is proportional to the field,

ionization by collision will be confined, under the conditions of the experiment, to the space near the central wire where the field is strong, and will thus be due entirely to ions of the sign driven across the chamber. We can thus study the effect of each kind of ion separately. The results of such an experiment are shewn in Fig. 23 where the lower curve refers to the positive ion and the upper to the negative. It will be seen that the positive ions produce no increase in the saturation current across the chamber at any rate until the voltage exceeds 350 volts. The negative however produce an appreciable increase in the current with a voltage as low as 100 volts. Thus until the field is very large ionization by collision is due almost entirely to the action of the negative ions in the gas.

28. Expression for the current through the gas when ionization by collision occurs. Confining our attention for the moment to the case where the ionization by collision is produced only by negative ions, let us consider the current between two parallel plates separated by d cm. of gas. Let n_0 be the number of ions generated per cubic cm. of gas by the ionizing agent at a distance x from the positive electrode. Let α be the number of ions which a single negative ion produces by collision in 1 cm. of its path. α will depend on the field and on the mean free path, but will be constant under the conditions of any one experiment. Then assuming that the ions so formed will in turn produce fresh ions by their collision the number of ions generated by collision in a distance dx will be equal to $\alpha n dx$, where n is the total number of negative ions present per unit volume at the point considered. Hence the rate at which negative ions are increasing as the positive electrode is approached is given by

$$\frac{dn}{dx} = \alpha n.$$

Thus the number reaching the positive electrode, which is equal to the sum of all the ions generated, is given by

$$\log n/n_0 = \alpha x \text{ (on integrating),}$$

$$\therefore n = n_0 \epsilon^{\alpha x} \dots \dots \dots (24)$$

In other words for every n_0 ions produced in a plane at a distance x cm. from the positive electrode a number $n_0\epsilon^{\alpha x}$ reach the positive electrode, assuming that there is no recombination.

If the ionization is confined to a single plane at a definite distance x from the positive electrode this expression will give the current across the gas. This is the arrangement generally adopted in experiments. If, however, the gas is uniformly ionized throughout its volume, the number of ions formed per c.c. per sec. being n_0 as before, we may proceed as follows. Consider two planes distant x and $x + dx$ from the positive electrode, the number of ions formed in this layer will be $n_0 dx$ and the number reaching the positive electrode due to this layer $n_0\epsilon^{\alpha x} dx$. The total number reaching the positive electrode will thus be the integral of this from $x = 0$ to $x = d$

or
$$\int_0^d n_0\epsilon^{\alpha x} dx = n_0 \frac{\epsilon^{\alpha d} - 1}{\alpha},$$

where d is the distance between the two electrodes. If there were no ionization by collision the number reaching the electrode in the same time would be $n_0 d$ which is the number formed by the ionizing agent in the same time. Hence, since the currents are proportional to the number of ions, the actual current i across the gas is given by

$$i = i_0 \frac{\epsilon^{\alpha d} - 1}{\alpha d}, \quad \dots \dots \dots (25)$$

where i_0 is the saturation current.

Similarly equation (24) can be written in the form

$$i = i_0\epsilon^{\alpha x}.$$

29. Townsend's experiments. Determinations of α have been made by Professor Townsend, to whom the above analysis is due, using a form of apparatus shewn in Fig. 24. He found it more accurate to adopt the arrangement in which the ionization is confined to a definite plane, in this case the surface of the negative electrode. This can easily be effected by using ultra-violet light as the ionizing agent. We shall see (Chapter IX) that ultra-violet light such as is given out by a quartz mercury arc lamp is unable to ionize a gas, but produces a copious

LONDON HOSPITAL MEDICAL COLLEGE

emission of electrons when allowed to fall on a metal plate. These form negative ions on entering the gas by attaching themselves to the uncharged molecules, so that the negative ions may all be regarded as starting from the illuminated plate. It will be noted that in this case there will only be a current through the gas if the illuminated plate is negatively charged.

The ultra-violet light passes into the apparatus through a quartz window *W* and through the lower electrode *P* which consists of a quartz plate silvered on its upper surface. The

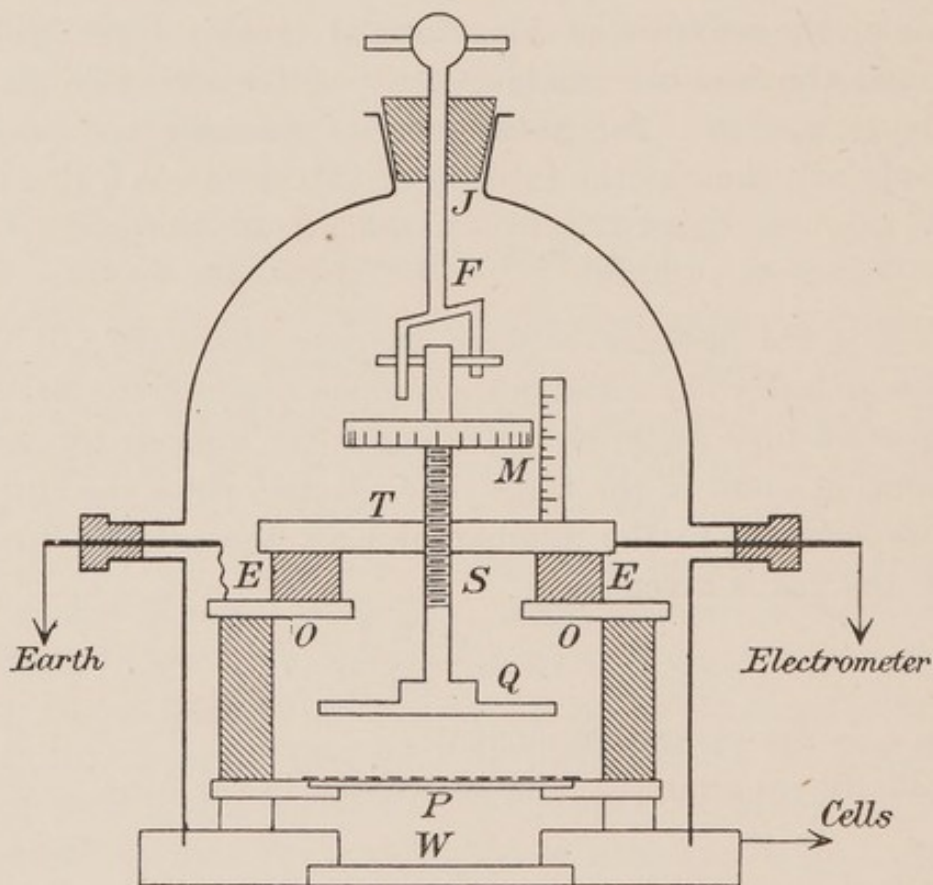

Fig. 24

silvering which is of course opaque is removed in a series of fine parallel scratches over the central part of the plate. The light passing through these scratches falls on the upper electrode *Q*, which is of zinc, since this metal gives a very large emission of electrons under the action of ultra-violet light. The plate *Q* can be moved parallel to itself by means of a thick screw *S* working in a thick brass plate *T*, which is connected to the electrometer by a wire *e*. A micrometer head and scale *M*

allows the position of the plate to be read accurately. The plate P is in metallic connection with the metal base of the instrument and is charged to a suitable voltage by means of a battery of cells. In order to ensure that no charge should reach Q except through the gas, a metal ring O divides the blocks of ebonite E , E separating P from T , and is put to earth. The screw S can be rotated (and the distance between the electrodes thus varied) by means of the fork F which engages two projections on the head of the screw. When readings are to be made the fork F can be turned so as not to touch the screw and thus perfect insulation is ensured. The fork F is operated from outside the apparatus by means of an air-tight ground glass joint, J .

In this apparatus the ions are all formed at the surface of the plate Q and hence the total current through the apparatus, if the intensity of the illumination remains constant, should be given by the equation

$$i = i_0 \epsilon^{\alpha x}$$

where i_0 is the current before ionization by collision sets in, and x is the distance between the plates. Since the value of α depends on the *field*, and not directly upon the potential difference between the plates, the voltage must be adjusted for each reading so that the field, which is equal to V/d , remains constant for the experiment. On making the experiments it was found that the relation (24) was accurately true for a very considerable range of fields.

The value of α could be deduced by making experiments at two different distances. In this case we have from (24)

$$\frac{i_2}{i_1} = \epsilon^{\alpha(d_2 - d_1)}$$

in which $d_2 - d_1$ is the distance through which the plate Q has been raised and is read off directly on the micrometer scale M .

As the ions do not reach their average velocity under the field until they have passed through a thickness of gas comparable with the mean free path in the gas, the equation will obviously no longer apply if the distance between the electrodes is comparable with the mean free path of the ions

in the gas. Hence the apparatus must not be used with too small a distance between the electrodes or, since the m.f.p. $\propto 1/\text{pressure}$, with too small pressures of the gas. The pressure can be read off on a gauge attached to the apparatus. Within these limits, and if the experiments are confined to the range of pressures and fields for which the effect of the positive ions in causing ionization is negligible, the results obtained are found to agree very closely with the theoretical curve.

30. Variation of α with pressure and field. The question as to whether a given collision will produce ionization depends, as we have seen, on the energy with which the ion strikes the molecule. The velocity of approach is given by $X \frac{e \lambda}{m \bar{V}}$. But λ is inversely proportional to the pressure p of the gas, so that if X and p are both increased or decreased in the same ratio the velocity and consequently the energy of impact will be unaltered, and the proportion of collisions which result in ionization will remain the same. On the other hand, the total number of collisions is directly proportional to the pressure, and thus increases as p is increased. Thus α is directly proportional to p , and also to some function of $\frac{X}{p}$. These results are expressed mathematically in the form

$$\frac{\alpha}{p} = f\left(\frac{X}{p}\right), \quad \dots \dots \dots (26)$$

where $f\left(\frac{X}{p}\right)$ represents some undetermined function which remains constant so long as the ratio $\frac{X}{p}$ is constant. Thus if a curve is plotted between $\frac{\alpha}{p}$ and $\frac{X}{p}$ the results should lie on a smooth curve. Professor Townsend, experimenting with various gases under many conditions, found this to be the case.

If we apply the results of the kinetic theory of gases to our assumptions we can calculate the form of the function of X/p which occurs in our equations. The probability that a particle will have a free path greater than some value x

is given by $\epsilon^{-\frac{x}{\lambda}}$ * where λ is the mean free path of the particle in the gas. If Y is the total number of collisions made by a particle in passing through unit distance of the gas the total number of collisions terminating free paths greater than x will be $Y\epsilon^{-\frac{x}{\lambda}}$. But since the mean free path is λ we have $Y\lambda$ equal to 1. Hence the number of collisions in a cm. of gas terminating free paths greater than x is equal to $\frac{1}{\lambda}\epsilon^{-\frac{x}{\lambda}}$. The velocity of the ion on striking the molecule at the end of a free path x is proportional to Xx where X is the field, assuming that the velocity is due entirely to the field. If we assume that ionization will occur if this velocity exceeds some constant value V we have $Xx \propto V$ or $x \propto V/X$. Substituting for x in the equation and remembering that λ is inversely proportional to p , we have

$$\alpha = Cp\epsilon^{-\frac{CVp}{X}} \quad . \quad . \quad . \quad . \quad . \quad (27)$$

which gives us the required expression.

For a given field the value of α reaches a maximum for some particular pressure, obtained by differentiating this equation with respect to p , and equating to zero. In this way we have

$$p_{\max.} = \frac{X}{VC} \cdot \quad . \quad . \quad . \quad . \quad . \quad (28)$$

The experimental results obtained by Townsend are found to agree closely with these equations.

The value of α thus depends on the pressure and the field; it also depends on the nature of the gas. It may be mentioned, as giving some idea of the order of the effect, that in air at a pressure of 4.1 mm. and with a field of 200 volts per cm. the value obtained by Townsend for α was .50. With the same pressure, but with a field of 320 volts per cm. α was 2.1; that is to say each ion produced rather more than two fresh ions along each cm. of its track through the gas. The number may, however, be much greater than this. Thus in carbon dioxide at a pressure of 3.95 mm. and with a field of 972 volts

* Meyer, *Kinetic Theory of Gases*, § 26.

per cm., the number of fresh ions produced along each cm. of the track was no less than 4330.

Although the most accurate results are obtained by ultra-violet light, the apparatus can be modified to allow the use of other ionizing agents. It is found that the results are the same whether the ionization is due to the action of, say, X-rays on the gas itself or to the liberation of electrons from the metal electrode. Thus the nature of the ions depends only on the gas and its pressure and is independent of the nature of the ionizing agent.

31. Average velocity required to produce ionization. The method of ionization by collision enables us to obtain a

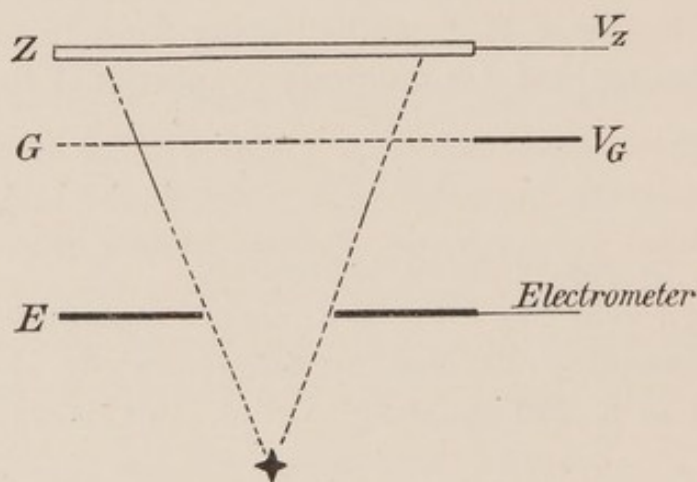

Fig. 25

value for the minimum velocity required to produce an ion in a gas. The simplest arrangement is that indicated in Fig. 25. The electrons are liberated by the action of ultra-violet light on a zinc plate Z , while parallel to this at some little distance from it are a piece of wire gauze G and a metal ring E , the latter being connected to an electrometer. The ring E is at zero potential, while G and Z are both maintained at a positive potential the potential of G being greater than that of Z . The electric fields are thus directed in each case from the gauze to the solid plate. Consider now an electron liberated from the plate Z . It is acted upon by the field and reaches G with a velocity v , given by $Ve = \frac{1}{2}mv^2$, $v^2 = \frac{2Ve}{m}$ where V is the potential difference between the two plates. If this velocity

is sufficient to produce ionization by collision with the molecules of the gas, positive ions will be formed in the space between G and E and will find their way under the action of the field to the electrode E , and there will thus be a current through the gas which will be recorded by the electrometer. If no collisions result in ionization the negative ion on entering the space between G and E finds itself in an adverse field and since $V_G - V_E$ is greater than $V_G - V_Z$ the velocity of the ion will be reversed before reaching E and it will return to the electrode G or Z . Thus the minimum difference of potential between Z and G for which a current is registered in the electrometer gives the minimum potential energy required to ionize the molecules of the gas between the electrodes.

Recent experiments made on this principle have shewn that the minimum value of $V_G - V_Z$ necessary to produce ionization is for hydrogen 11 volts, for oxygen 9 volts, for helium 20.5 volts and for nitrogen 7.5 volts. Since e has the value 4.7×10^{-10} e.s.u. and 1 volt is $1/300$ e.s.u. this corresponds to an amount of energy in the particles of 1.7×10^{-13} ergs in the case of hydrogen, 1.4×10^{-13} ergs for oxygen with corresponding values for the other gases. If the pressure is so low that we may assume that the negative particle is an electron the ratio $e/m = 1.77 \times 10^7$ e.m.u. per gm. and $V = 11 \times 10^8$ e.m.u. Substituting in the equation we find that the velocity which the particle must have to produce ionization in hydrogen is about 2×10^8 cm. per sec.

We have so far assumed that the ion is moving only under the action of the applied field. Owing to the fact that it is in a gas it will share the ordinary thermal agitations of the molecules of the gas and will thus have a velocity independent of that produced by the field. It can be shewn that for an electron at ordinary temperatures this velocity of thermal agitation would amount to about 10^7 cm. per sec. This is only one-twentieth of the ionizing velocity and hence can be neglected without introducing any serious error into our calculations.

32. Ionization by collisions with the positive ions. We have seen that if the field is less than a certain value ionization is produced only by the negative ions in the gas. It is

found, however, experimentally, that when the field is large the current increases more rapidly than would be the case if the negative ions alone were acting. For these fields we must assume that the positive ions also produce fresh ions by colliding with the molecules of the surrounding gas.

We can easily calculate the form of the expression for the current if we assume that a positive ion forms β fresh ions for each cm. of its path through the gas. The simplest case is that where the initial ionization is all produced at the negative electrode, for example, by the action of ultra-violet light. This corresponds to the experimental arrangements of Fig. 24.

Consider a pair of planes AB and CD parallel to the electrodes at a distance dx apart and x cm. from the negative electrode. Let p be the number of pairs of ions generated by both positive and negative ions between the negative electrode and AB , and q the number of pairs of ions generated between CD and the positive electrode. The number of ions arriving at the positive electrode per second is thus $n = p + q + n_0$ where n_0 is the number generated per second at the negative electrode. The number of pairs of ions generated between x and $x + dx$ is

$$(n_0 + p) \alpha dx + q \beta dx \quad . \quad . \quad . \quad . \quad . \quad (29)$$

since all the negative ions generated per second cross the planes in one direction and all the positive ions in the space below the planes cross them in the opposite direction, assuming that there is no recombination. This is obviously true since the saturation voltage is exceeded before ionization by collision begins. Substituting for q we have

$$\frac{dp}{dx} = (n_0 + p) (\alpha - \beta) + n\beta.$$

The solution of this equation is of the form

$$n_0 + p = A\epsilon^{-(\alpha-\beta)x} - \frac{n\beta}{\alpha - \beta}$$

and A can be found from the condition that $p = 0$ when $x = 0$. Thus substituting for A and solving for n we have

$$n = n_0 \frac{(\alpha - \beta) \epsilon^{(\alpha-\beta)d}}{\alpha - \beta \epsilon^{(\alpha-\beta)d}}, \quad . \quad . \quad . \quad . \quad . \quad (30)$$

where d is the distance between the electrodes.

This equation is due to Townsend and was carefully tested by him with the apparatus already described. It was found that an expression of this form represented the experimental results with considerable accuracy over the whole range of distances and forces.

The values of β are generally small compared with those of α and equation (30) shews that under these circumstances the effect of ionization by the positive particles will only be appreciable for large values of the field or for large values of d . The value of β deduced from the equation is relatively greatest in the case of hydrogen and decreases with increasing atomic weight of the gas. Thus for hydrogen in a certain experiment β was about one-fortieth of α , or the proportion of ions formed by collision of the positive particles per cm. was only one-fortieth of that formed by the negative. For air the ratio of β/α was less than one per cent. and for carbon dioxide less than 1/1000.

The positive ions are molecules of the gas, while the negative as we have seen are at the pressures used in these experiments probably electrons. Thus we see that for a given amount of energy the efficiency of a particle as an ionizing agent decreases rapidly as the size of the particle is increased.

33. The spark discharge. The equation (30) just developed suggests curious possibilities. It is evident that the current will become infinite for some distance d such that

$$\alpha = \beta e^{(\alpha - \beta)d} \dots \dots \dots (31)$$

This case corresponds to what is known as the spark discharge. A considerable amount of experimental research has been devoted to the spark discharge. If two electrodes are separated by a gas at any pressure and the difference of potential between them is gradually increased eventually a point is reached at which a bright spark accompanied by the well-known crackling noise will pass between them and the two conductors become completely discharged. If the difference of potential is continuously restored by connecting the two electrodes to an electrical machine a continuous torrent of sparks is obtained

which may pass into the form of an arc. In this case the current may rise to many amperes.

The spark may also be made to pass by bringing the electrodes nearer together as in the case of the discharge of a Leyden jar by discharging tongs, or by reducing the pressure of the gas between the electrodes. This latter is, however, only effective down to a certain point. It is found that for any given distance apart of the electrodes there is a critical pressure at which the discharge passes most easily. Reducing the pressure below this critical value causes a very rapid rise in the potential necessary to produce a spark, so that the potential at very low pressures may easily exceed by many times that which would suffice to produce discharge at the same distance in air at atmospheric pressure.

The critical potential difference between the electrodes necessary to produce a spark is called the sparking potential. If we assume that the spark takes place between two parallel plate electrodes situated S cm. apart the value of the sparking potential is equal to XS where X is the field between the plates.

Thus if α and β are the two coefficients of ionization under the conditions of the experiment, sparks should pass between the electrodes when their distance apart is given by

$$\alpha = \beta e^{(\alpha - \beta)S} \quad . \quad . \quad . \quad . \quad . \quad (32)$$

and the sparking potential should be equal to XS where X is the field between the plates.

This equation was tested by Townsend. α and β were measured for some definite field X and the value of S calculated from equation (32). The plates were then set at this distance apart and the potential difference between them gradually increased until a spark passed. The minimum sparking potential as thus obtained was found to agree in every case with the product XS as previously determined, the divergence between the two values being less than one per cent. This agreement is strong proof of the substantial accuracy of the theory.

It will be seen that this theory requires the existence of a certain number of free ions in the gas between the electrodes if the spark is to pass. Under normal circumstances the air

generally contains a few ions especially if the electrodes are illuminated by sunlight which contains a small proportion of ultra-violet light. If, however, the ions present are very few, as, for example, if the sparking experiments are made in the dark, a considerable time may elapse before the small number of ions originally present have increased sufficiently in number to give rise to a spark discharge, and under these circumstances the difference of potential may be increased considerably beyond the critical sparking potential without a spark passing. This phenomenon is well known and is called the retardation of the spark. Under certain circumstances this retardation may amount to several minutes. It is reduced to zero if the negative

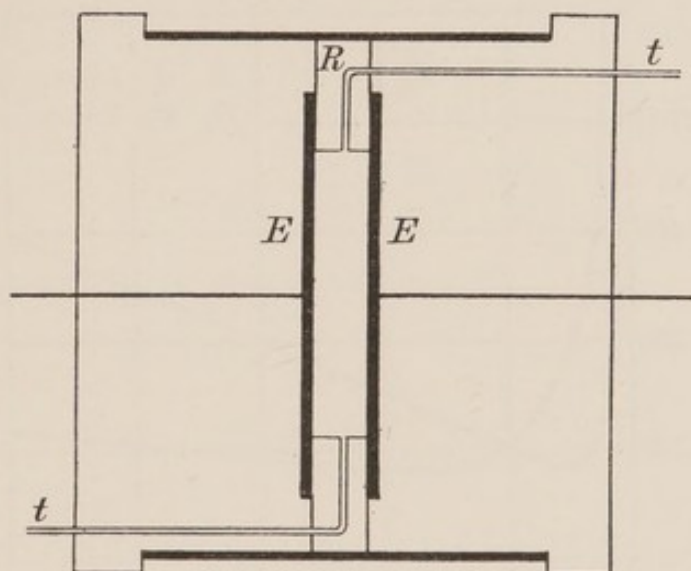

Fig. 26

electrode is exposed to a weak source of ultra-violet light. Many early experiments were vitiated by the neglect of this precaution.

34. Sparking potential for parallel plate electrodes. The conditions are most easily interpreted when the electrodes take the form of a pair of parallel plates. Experiments of this kind have been made by Carr, using apparatus as shewn in Fig. 26. If the discharge is taken between two metallic plates in the usual way it is found that the spark always passes between rough points or small projections on the edges of the disks. To avoid this the electrodes *E, E* were completely embedded

in ebonite except for a portion near the centre which was carefully planed and polished. The plates were separated by ebonite rings R of varying thickness so that spark lengths of different values could be used. The gas to be experimented on could be introduced by fine tubes t, t running through the ebonite, and the whole apparatus was made air-tight.

The experiments shewed that for a given gas there was a minimum potential difference depending only on the nature of the gas below which a spark would not pass. For any given distance between the plates it was always possible to find some pressure at which the spark passed at this minimum potential. Either increasing or decreasing the pressure from

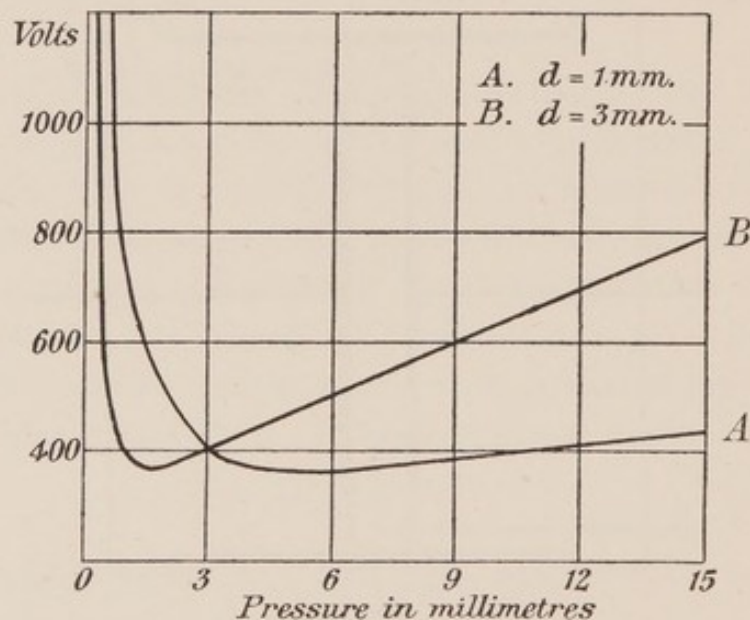

Fig. 27

this critical value increased the sparking potential. These results are shewn in Fig. 27 which represents some of Carr's observations on air at various pressures and for various distances between the electrodes. Similar results were obtained for other gases. The minimum sparking potential for hydrogen is about 280 volts, the critical pressure being 10.3 mm. when the sparking distance is 1 mm. and 1.46 mm. with a sparking distance of 10 mm. For air the minimum potential is about 340 volts and for carbon dioxide 419 volts. Within the limits of experimental error the product of the sparking distance into the critical pressure is a constant for a given gas. For different gases this

product is approximately proportional to the mean free path of the molecules of the gas.

35. Paschen's Law. As the result of a large number of experiments Paschen came to the conclusion that the sparking potential was a function only of the product of the sparking distance into the pressure of the gas, that is to say, of the mass of gas between unit area of the electrodes. This result applies also to the case of the discharge between two spheres if the distance between the spheres is appreciably less than the radius of curvature. It can easily be shewn that this result follows from the theory given above. Let V be the sparking potential. Then $V = SX$, and if M represents the product pS we have from (26)

$$\alpha = pf\left(\frac{X}{p}\right) = \frac{M}{S} f\left(\frac{V}{M}\right),$$

$$\beta = p\phi\left(\frac{X}{p}\right) = \frac{M}{S} \phi\left(\frac{V}{M}\right).$$

Hence, substituting in the equation (32),

$$\alpha = \beta e^{(\alpha - \beta)S}$$

we have $(\alpha - \beta)S = \log_e\left(\frac{\alpha}{\beta}\right)$,

$$\therefore M \left[f\left(\frac{V}{M}\right) - \phi\left(\frac{V}{M}\right) \right] = \log \left[f\left(\frac{V}{M}\right) / \phi\left(\frac{V}{M}\right) \right], \quad (33)$$

thus shewing that the sparking potential V depends only on M , that is, the product pS . Carr has shewn that this law is true for all pressures both above and below the critical pressure. It is thus a result of great importance. It follows that if p and S are varied in such a way that the product pS remains constant the sparking potential will be unaltered. Hence in order to be able to calculate the sparking potential for any given distance apart of the electrodes, and for any pressure of the gas, it is only necessary to have a complete set of observations on the variation of sparking potential and pressure for one definite spark length. For example to find the value of the sparking potential for a sparking distance of 10 cm. in air at 10 mm. pressure, in which case the product pS is 100, reference to

a standard curve for air shews that this product corresponds to a sparking potential of 5000 volts.

At pressures considerably above the critical pressure the relation between V and pS is practically linear and we can write

$$V = A + B(pS). \quad . \quad . \quad . \quad . \quad (34)$$

For air the values of A and B are respectively 1700 and 39; for hydrogen 1860 and 25.6.

36. Variation of sparking potential with temperature. Paschen's law applies also to different temperatures at any rate up to 300° C. Thus if the experiment is arranged so that the mass of gas between the electrodes remains constant (i.e. if the vessel is air-tight) increasing the temperature produces no alteration in the spark gap. If the gas is allowed to expand the sparking potential is that associated with the new density of the gas.

37. The brush discharge. If the conductors are of small dimensions and are separated by considerable distances so that the field between the electrodes is far from uniform the discharge presents a different appearance. Instead of one or more bright sparks passing completely from one electrode to the other a luminous brush is formed at the part of the conductor where the field is most intense fading away as the distance from the electrode increases. If the brush is examined minutely it is seen to consist of a large number of small sparks commencing at the electrode and terminating in the air. The luminous discharge is thus not continuous between the electrodes. If, however, the pressure of the gas is reduced the luminosity may grow until it reaches completely from one electrode to the other, in which case it is frequently striated.

The minimum potential required to start a brush discharge from a point depends on the sign of the point; the requisite potential being greater for a positive point than for a negative. The conditions for a discharge are obviously that the positive ions shall be able to acquire sufficient energy to produce an adequate supply of negative electrons to carry the current.

Now if the point is negative the positive ions are moving towards it and may produce electrons (1) by collision with the molecules of the gas, as in the cases already considered, and (2) by collision with the metal of the electrode. If the point is positively charged only the first of these sources is available and hence we might expect that the discharge would pass more readily from a negatively than from a positively charged point.

Let us suppose now that the point is equivalent to a small sphere of radius a . If the potential of the sphere is raised to V the difference in potential between the sphere and a point distant x from its surface is given by $Vx/(a+x)$. Suppose α , Fig. 28, is the curve connecting sparking potential with distance for the given pressure of the experiment. If the

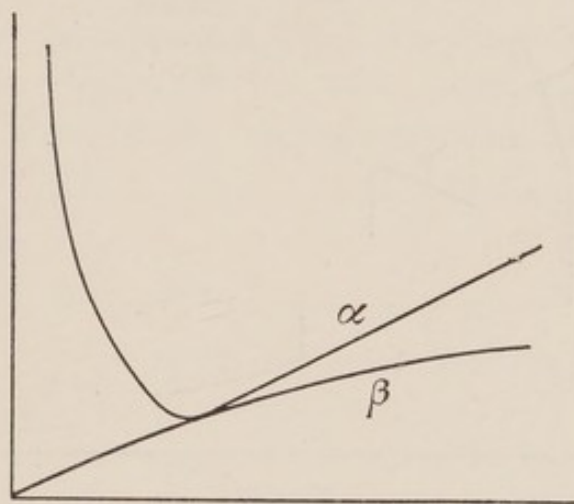

Fig. 28

difference of potential is so large that the curve β between difference of potential and distance cuts the sparking curve, a discharge will take place from the point to the air. The smallest value of the potential of the point for which the discharge takes place will be when the curves just touch as shewn in the figure. It can easily be seen from the character of the curves that they must touch at some point not far distant from the minimum sparking potential. Hence approximately

$$V \frac{x_0}{a+x_0} = V_0$$

$$V = \left(1 + \frac{a}{x_0}\right) V_0 \quad \cdot \quad \cdot \quad \cdot \quad \cdot \quad \cdot \quad (35)$$

where V_0 is the minimum spark potential, and x the corresponding distance.

38. The dark discharge. Although we have considered the conditions that a discharge may take place, it by no means follows that the discharge will be a luminous one. The discharge between a point and a plane frequently commences, and can be measured by a galvanometer, before any sign of luminosity is to be seen. If the potential of the point is increased a glow forms on the point and subsequently a brush discharge may be formed. If the *current* is increased sparking takes

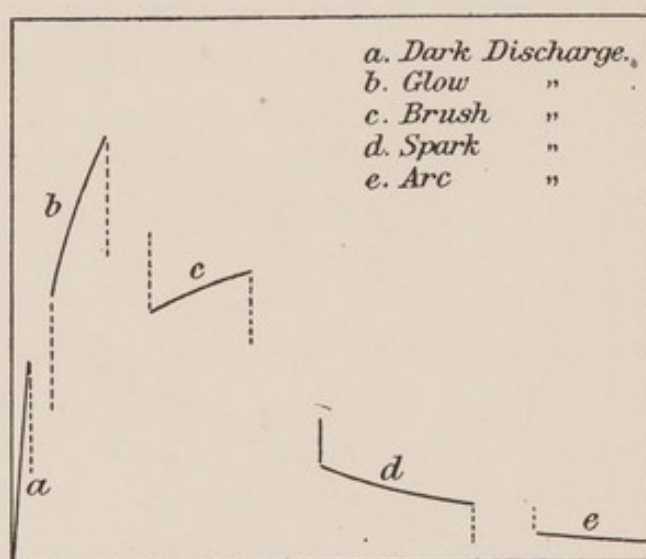

Fig. 29

place, which with further increase in current may produce an arc. At this stage the ratio of the current to the potential difference is very largely increased. In the case of the arc discharge the electrons carrying the current come mainly from the electrodes which usually become intensely hot. The conditions are, therefore, somewhat different to those of the spark, where the ions are formed from the molecules of the gas, and we shall not consider it further at this point. These results are shewn graphically by the curves in Fig. 29, in which the ordinates represent potentials and the abscissae the corresponding values of the current.

CHAPTER VI

THE PHENOMENA OF THE DISCHARGE TUBE

39. **Phenomena of the discharge in a gas at low pressure.** If the discharge takes place between electrodes enclosed in a glass tube, containing gas at low pressure, say, from a millimetre or so downwards, some very beautiful and interesting effects are observed. If the potential difference across the tube is not much more than the minimum necessary to maintain a current through the tube the luminosity is at first confined to the region of the two electrodes, the rest of the discharge being dark, as indicated in Fig. 30. As the

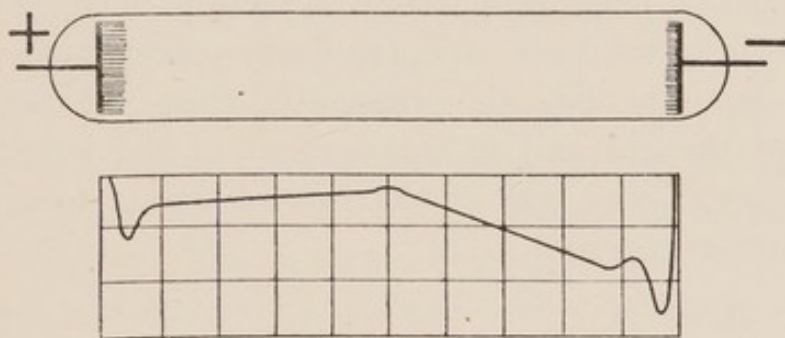

Fig. 30

pressure of the gas is reduced, say, to about one mm. or so of mercury, the two glows extend outward especially that at the positive electrode which now occupies the major portion of the tube. The potential necessary to maintain a current across the tube has now its minimum value.

As the pressure is still further reduced it is seen that the glow near the cathode consists of two parts separated by a dark space. The glow nearest the cathode, covering its surface with a velvety light, is called the *cathode glow*, the other which is much more extensive stretching at low pressures some considerable distance into the tube is known as the *negative glow*. The space between them which is comparatively non-

luminous is the *Crookes dark space*, while the similar region between the negative glow and the positive column is known as the *Faraday dark space*. At pressures of a millimetre or so of mercury the positive column presents a uniform luminosity, but as the pressure is reduced it generally breaks up into a series of bright and dark striae. The typical appearance of a

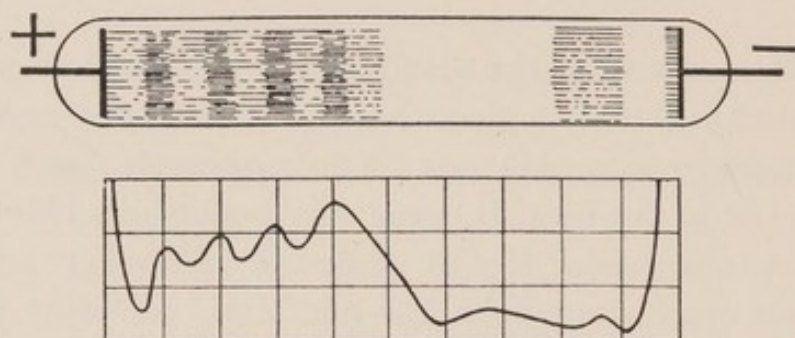

Fig. 31

discharge tube at this stage is represented in Fig. 31, which corresponds to a pressure of about half a mm. in the case of air.

The length of the tube occupied by the phenomena near the negative electrode depends principally upon the nature and pressure of the gas and is independent of the length of the discharge tube. The rest of the tube, however long, is filled by the positive column.

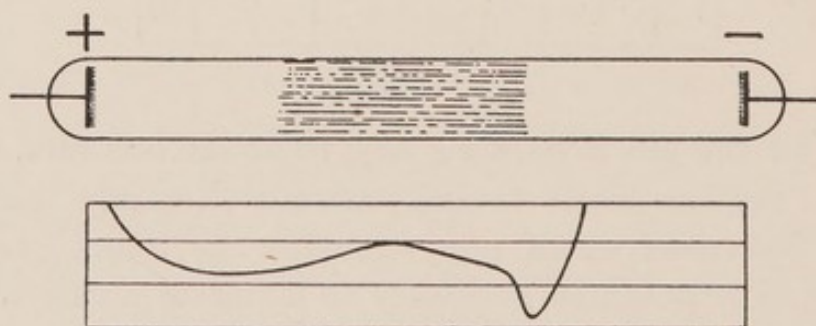

Fig. 32

As the pressure is reduced still further the negative glow and the Crookes dark space increase in length while the positive column contracts towards the anode and at very low pressures is represented only by a feeble glow on the surface of the anode (Fig. 32); at this stage there is no region of constant intensity in the tube. Finally if the exhaustion is pushed to extreme

limits as in a X-ray bulb, the Crookes dark space expands until it fills the whole of the discharge tube which is then entirely dark. At this stage the walls of the glass vessel fluoresce brightly, the fluorescence being bluish with soda glass, and greenish with German glass. The greenish coloration is probably due to traces of manganese.

40. Investigation of the intensity of the field in various parts of the discharge. The electric intensity in various parts of the discharge has been investigated by many observers. The most usual way is to insert in the tube a small subsidiary electrode consisting of a fine pointed platinum wire. If there are free ions in the tube and the potential of the wire is less than the potential of the space in its immediate neighbourhood there will be a field in the gas tending to drive ions of the appropriate sign up to the wire. For example if the wire has a smaller potential than the surrounding gas the field will drive up positive ions until the potential of the electrode becomes equal to that of the gas.

The accuracy of the method obviously depends on there being a plentiful supply of ions of both signs in the gas around the wire. If ions of one sign only are present the results may be very misleading. For example supposing only negative ions are present which is practically the case at points in close proximity to the anode, these negative ions will strike the surface of the wire and continue to do so until its negative potential is so high as to prevent by its electric repulsion any further ions from reaching it. As there are no positive ions to neutralize it, it will thus acquire a negative potential which may be considerably higher than that in any part of the original space before the introduction of the wire. Hence at points very near either electrode the results obtained by the exploring wire are apt to be misleading. In the main part of the discharge its results are no doubt sufficiently near the truth.

The method has been applied by means of the apparatus shewn in Fig. 33. The electrodes *C* and *A* were kept at a fixed distance apart by means of the glass rod *d* to which they were both attached. The glass tube containing the electrodes was

much longer than the distance between the electrodes which were connected to terminals passing through the ends of the tube by long wire spirals. A piece of soft iron R attached to one electrode enabled the electrodes to be moved about from one end of the tube to the other by means of a magnet. Two electrodes, e, f , were sealed into the tube, the line joining them being along the axis of the tube, and their distance apart about 1 mm. If the two electrodes are connected to opposite quadrants of an electrometer the deflection indicates the difference of potential between the two points: that is, since ef is constant, it is proportional to the field in the gas in the region of e, f . By sliding the electrodes along this region could be made to coincide with any part of the discharge, and in this way the field in any part of the discharge could be investigated.

An ingenious method which does not involve the uncertainties of the previous method is due to Sir J. J. Thomson. In this

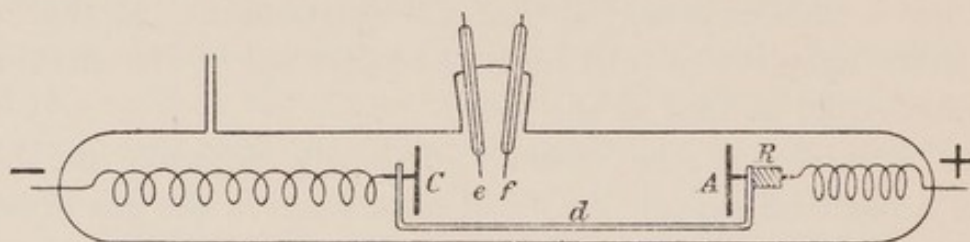

Fig. 33

the fact that a beam of cathode rays is deflected by an electric field is made use of. It will be shewn later (§ 46) that the deflection of the rays is proportional to the field through which they pass. The main discharge passes between C and A (Fig. 34), the experimental devices for moving the discharge electrodes being the same as in the apparatus just described. The cathode rays are generated in a side tube T at right angles to the discharge, and pass across the main discharge through a fine hole in the metal ring G which serves as anode. The deflected beam passes down a long tube S falling on a screen at the end of the tube where the deflection of the beam is readily measured. This method has been applied to investigate the field very near the cathode.

The results obtained vary somewhat with the state of the discharge, and are shewn in Figs. 30-32 immediately below the

diagrams of the discharge to which they refer. It will be seen however that they present certain constant features.

Starting at the cathode there is a very strong field in the Crookes dark space which drops with considerable rapidity as we approach the negative boundary of the negative glow where indeed it reaches its minimum value for the tube. Since the field is very strong the fall of potential between the surface of the cathode and the edge of the negative glow is very considerable and in many cases accounts for the greater part of the whole fall of potential across the tube. This is known as the *cathode fall of potential*. The field in general rises again slightly

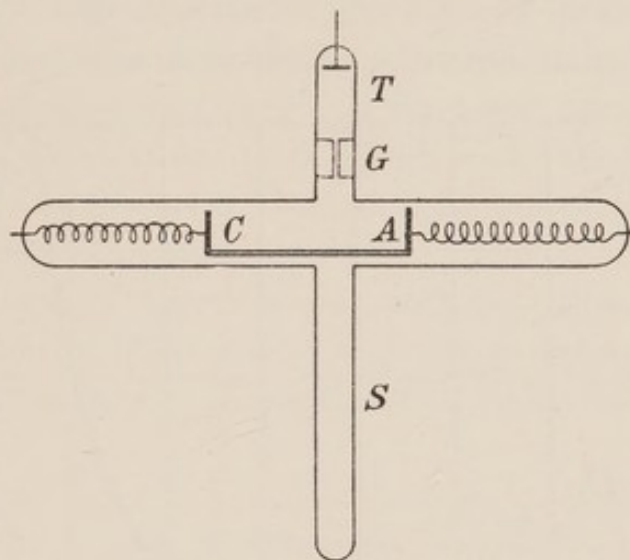

Fig. 34

in the negative glow and falls again in the Faraday space rising gradually as the edge of the positive column is approached.

If the positive column is uniform or unstriated the field has a constant value until the neighbourhood of the anode is reached when there is again a sharp increase in the field accompanied by rapid increase of potential up to the anode. This anode fall of potential is, however, always much less than that at the cathode.

If the column is striated the field shews variations superimposed upon the steady field, the field being a maximum where the striation reaches its maximum brightness. This is shewn in Fig. 31.

41. Number of ions in various parts of the discharge. The apparatus of Fig. 33 can be modified so as to give the

relative number of ions in different parts of the discharge. If the two points *e*, *f* are replaced by two small plates, their planes being parallel to the discharge, the current between the plates when some small constant difference of potential is maintained between them (say, for example, that of a Clark cell, which will suffice to produce the saturation current between the plates at these low pressures) will be proportional to the sum of the ions of each kind present in the gas at the given point. In this way by moving the discharge so that various parts of it come between the plates the distribution of ions in the discharge can be found. The results obtained by H. A. Wilson are shown in Fig. 35. It will be noticed that the number of ions is very small near the anode and again in the Crookes

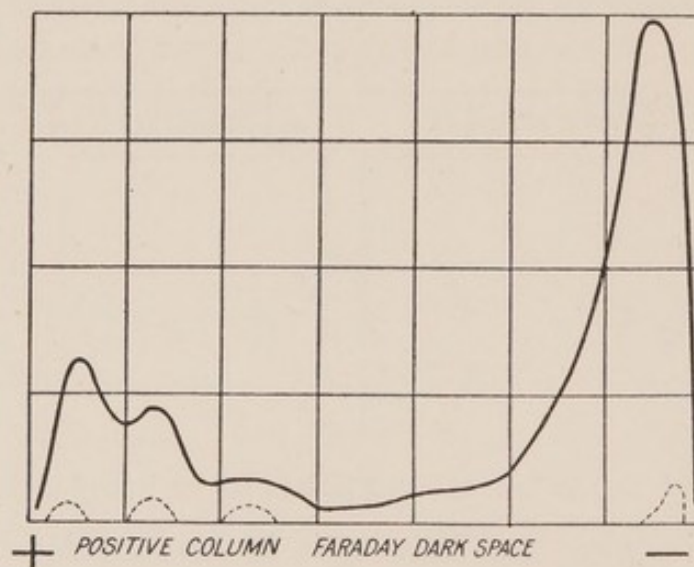

Fig. 35

dark space. It rises to a maximum in the negative glow, falls again in the Faraday dark space to rise again in the positive column. If the column is striated the ions are most numerous in the luminous parts and less numerous in the dark parts.

42. The cathode fall of potential. The fall of potential which occurs in the neighbourhood of the cathode is often a very large fraction of the whole fall of potential across the tube. If the current density of the discharge is not too large the cathode fall depends only on the nature of the gas and of the electrode and is independent of the potential difference between the

electrodes. If the current density is low the cathode glow only occupies part of the cathode, the area covered increasing as the current is increased. As long as the cathode is not completely covered the cathode fall remains constant; after this stage is passed, if the current through the tube is still further increased, the cathode fall increases with the current.

The fall of potential varies with the nature of the gas. For platinum electrodes it is about 340 volts in air, 300 volts in pure hydrogen, 167 volts in argon, and 470 volts in water vapour. The value is very nearly the same for electrodes of any of the less electropositive metals such as platinum, silver, copper, or iron, but is considerably reduced in the case of the active metals such as magnesium, sodium, or potassium. In the latter case the normal fall is no more than 172 volts in hydrogen, and 69 volts in argon, which is the smallest value yet recorded. This is probably due to the ease with which these metals emit negative electrons.

The anode fall of potential is much less than that at the cathode and varies little either with the pressure or nature of the gas, or the nature of the electrodes. It lies between 18 and 24 volts.

43. Theory of the discharge. The theory of ionization by collision can be extended to include the phenomena of the discharge tube. Let us suppose that the discharge is passing through the tube and that conditions have become steady. The ions necessary to carry the current from one electrode to the other are supplied by the collision of the ions already present with the molecules of the residual gas. It is evident that, in the absence of an external agent, a continuous supply of ions can only be obtained if both positive and negative ions produce fresh ionization in this way. Consider first the positive ions in the gas. The field near the negative electrode is many times greater than the field at any other part of the discharge. Hence the positive ions will attain their maximum velocity in the neighbourhood of the cathode. It is uncertain whether the negative ions are produced by the impact of the positive particles on the metal of the cathode itself or on the molecules

of gas near it. In any case since the field increases so rapidly near the cathode the bulk of the ionization will occur in a layer of the gas so near the cathode that the negative ions may be regarded as starting from the cathode itself. As the cathode field is so great the negative particles formed will be removed with considerable velocities by the field and hence there will be very few negative ions in the immediate neighbourhood of the cathode. This has been proved experimentally by Sir J. J. Thomson. There will thus be a considerable accumulation of positive ions just in front of the cathode. This accumulation of positive electricity near a negatively charged surface explains the very large values of the field in this region.

The negative particles, which at these pressures are all electronic, will move away from the cathode with high velocities and will produce ions by collision with the molecules of the residual gas. If we associate luminosity with ionization the gas will become luminous when ionization commences and this point will mark the beginning of the negative glow. The Crookes dark space, therefore, represents the distance fallen through by the negative particles before collision begins, and thus should be comparable with the mean free path of the electrons in the gas. This is found to be approximately the case. The presence of the excess positive charge in the Crookes dark space, however, reduces the value of the electric field in the space beyond it. Hence the field in the negative glow falls rapidly to a value which soon becomes insufficient to give to the electrons the energy necessary to produce fresh ionization, and luminosity ceases. This corresponds to the commencement of the Faraday dark space. The current in the dark space is here carried by negative ions drawn from the negative glow. There is, therefore, an excess of negative electricity in the dark space and this accumulation tends to increase the field between the dark space and the positive electrode. The field thus increases steadily through the dark space and finally attains a sufficiently high value to enable the negative ions again to ionize by collision. Hence luminosity is restored and we have the beginnings of the positive column. As the field in the positive column remains practically uniform,

ionization by collision of the negative ions will occur along its whole length and we shall get a uniform column of light. If, however, there happens to be an accumulation of positive ions at any point, this may produce a local fall of field and the discharge will cease to be luminous at that point. Just as in the case of the Faraday dark space this loss of ionizing power will be attended with an accumulation of negative electricity which will restore the field to its normal value. Thus a series of striae may be set up in the positive column, as is often found to be the case. The non-luminous parts of the striae on this hypothesis are thus a repetition of the phenomena of the Faraday dark space.

To sum up, luminosity occurs when the ions have sufficient velocity to produce fresh ions by collision; in the dark portions of the discharge the current is carried by ions drawn from the luminous parts of the tube.

It will be seen that on this hypothesis the phenomena are maintained by the collision of positive ions from the Crookes dark space with the cathode. That this is so may be readily illustrated by a very simple experiment. Some solid obstacle often in the form of a mica cross is placed in the tube and arranged so that it can be turned when required into the path of the discharge. If the obstacle is placed on the anode side of the Crookes dark space a shadow is cast on the anode owing to the stoppage of the stream of negative particles. If, however, the obstacle is placed within the Crookes dark space, not only is there a shadow cast on the anode but a corresponding shadow appears on the cathode; the glow entirely disappearing from that portion of the cathode which is shielded by the obstacle. Hence the phenomena at the cathode are due to particles approaching it from the boundary of the Crookes dark space. Since they approach a cathode they must be positively charged.

It is not necessary for the maintenance of the discharge that the average field across the tube shall be sufficient to cause the positive particles to ionize. It is sufficient that it shall rise to this value in a short region near the cathode. But the irregularities in the field between the electrodes which give rise to cathode fall of potential are due to the accumulation

of positive ions near the cathode. This accumulation is an effect of the discharge and is not initially present. Hence it will require a considerably higher voltage to start the discharge than will be necessary to maintain it when it has once begun. This result has also been verified. If the discharge is started by a small induction coil, a steady voltage of 470 volts is sufficient to maintain the discharge in air at a pressure of one mm. of mercury with a distance of 11.5 cm. between the electrodes. With this voltage the current was of the order of one milliampere. The voltage required increases as the pressure is reduced, a potential of about 1000 volts being required if the pressure is reduced to 1/10 mm.

If the pressure is very much reduced so that the tube is practically dark throughout, much higher voltages may be necessary. In the case of the tubes used for X-ray work 200,000 volts are often required to maintain a current of a few milliamperes across the tube, and it is possible to exhaust the tube to such an extremely low pressure that the highest potentials yet available are insufficient to start a discharge through it.

CHAPTER VII

CATHODE RAYS AND POSITIVE RAYS

44. **Cathode rays.** When the pressure in the tube is sufficiently low another phenomenon may be noticed, quite distinct from the glows already described, namely, a beam of bluish light proceeding normally from the cathode along the tube and penetrating to a greater or shorter distance along it as the pressure is comparatively low or high. If the pressure is sufficiently reduced these rays may reach the further boundary of the tube in which case vivid fluorescence is excited on the part of the glass on which they strike. These streamers are known as the *cathode rays*.

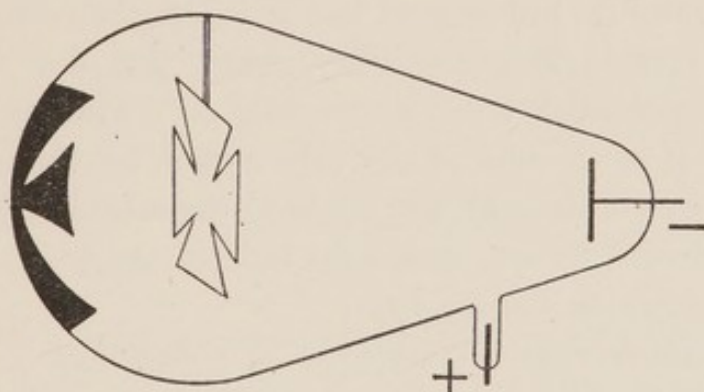

Fig. 36

The nature of these streamers was for long a subject of discussion. Goldstein, to whom the name is due, regarded them as some kind of disturbance in the ether. Crookes suggested that they were streams of highly charged particles of some very attenuated form of matter, projected by the electric forces from the surface of the cathode. The latter view is now universally accepted. The evidence for this hypothesis will appear from the following summary of the properties of the rays.

(1) *The rays travel in straight lines.* This can readily be shewn by constructing a discharge tube of the form of Fig. 36,

in which some obstacle, generally in the form of a mica cross, is placed in the path of the rays. A shadow of the obstacle appears in the centre of the fluorescence caused by the rays on the further boundary of the tube.

(2) *The rays emerge normally from the cathode.* If a tube such as that just described is constructed with a large plane cathode and a small obstacle such as a wire is placed near it a sharp shadow of the wire appears on the further wall of the tube without any sign of penumbra around it. If the rays were given off in all directions from the cathode (as, for example, light is emitted from a uniformly illuminated disk) no shadow of the wire would be seen. Similarly if the cathode is concave the cathode rays come to a focus at some point along the axis. Owing to the mutual repulsion of the rays the focus is generally somewhat beyond the geometrical centre of the concave surface. This property of the rays is made use of in the construction of X-ray tubes.

(3) *The rays can penetrate small thicknesses of matter* such as sheets of aluminium foil or gold leaf without producing perforations in the metal. This discovery, which was due to Lenard, can be demonstrated by constructing a "window" of thin aluminium leaf in the end of the tube struck by the rays. The passage of the rays through the foil is demonstrated by luminous blue streamers in the air on the far side of the leaf. These are sometimes known as *Lenard rays*.

(4) *The cathode rays are deflected by a magnetic field.* If an ordinary bar magnet is held near a discharge tube the deflection of the rays by the magnet is made evident by the movement of the fluorescent spot which they produce on the further boundary. We shall return to this important point later. The direction of the deflection shews that the cathode rays experience the same deflection as would be experienced by a flexible conductor coinciding with the path of the rays and carrying an electric current, the direction of the current being towards the cathode.

(5) *The rays carry a negative charge.* This was demonstrated by Perrin in 1895. A slight modification of Perrin's original experiment is shewn in Fig. 37.

The cathode *A* is contained in a small side tube which also contains the anode *B*. The rays starting from the cathode pass through a small slit in a brass plate *C* across the larger bulb *D*, where they manifest themselves by phosphorescence of the walls of the bulb. Enclosed in this bulb but out of the direct line of fire of the cathode stream is a small cylindrical vessel *E* having a small aperture facing the centre of the bulb. This vessel is carefully insulated and connected by the electrode *F* to an electrometer. The vessel is screened from the powerful electrostatic disturbances in the discharge tube by surrounding it with a nearly closed metal vessel *G* which is connected to earth. This arrangement forms what is known as a *Faraday cylinder*.

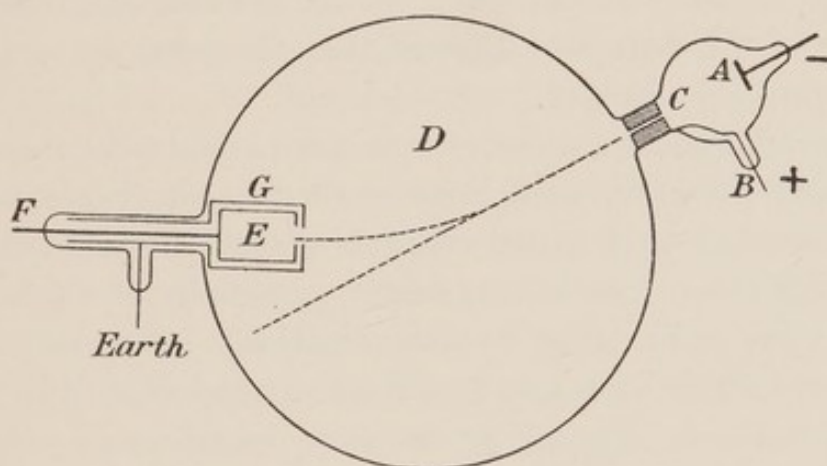

Fig. 37

When the discharge was passed the inner cylinder received a very small negative charge. If, however, the cathode rays were deflected by a magnet so as to fall on the openings in the Faraday cylinder a very large negative charge was recorded by the electrometer. This charge increased for some little time but finally became constant owing to the fact that the cathode rays turned the residual gas in the discharge tube into a partial conductor. The charge on the vessel increased until the loss by conduction through the ionized gas (which is roughly proportional to the potential of the Faraday cylinder) was equal to the gain from the cathode stream. This experiment proves conclusively that a negative charge is a necessary accompaniment of the cathode stream.

(6) *The rays are deflected by an electrostatic field.* This effect, which was a necessary consequence of the theory that the rays consist of charged particles, was for some time sought for in vain. The results just described gave a clue to the cause of the failure. We have seen that the cathode rays ionize the gas through which they pass, thus making it a partial conductor. In fact they move down the discharge tube through a sort of protecting conducting cylinder of their own construction, and are thus screened from the action of any electric field applied to the tube; there being, of course, no electrostatic field inside a closed conductor. By exhausting the tube very completely of the residual gas Professor Sir J. J. Thomson in 1897 succeeded in partially eliminating this effect and demonstrated the direct deflection of the cathode rays by an electrostatic field. The direction of the deflection shewed that the particles in the rays were negatively charged.

(7) In addition to these effects the cathode rays can exert mechanical pressure, and convey very considerable amounts of kinetic energy. A metal obstacle placed in the path of the rays quickly becomes incandescent, especially if the rays are focused upon it by using a concave cathode in the way already described. Much ingenuity has been expended by the makers of X-ray tubes in eliminating the very considerable production of heat at the point struck by the cathode rays. If the discharge is very powerful, portions of metal may be actually torn out of a solid plate by the impact of the rays.

A consideration of these facts leaves no doubt that the cathode rays consist of negatively charged particles. As we shall see these particles are identical with the electron, some of the properties of which we have already discussed. The supporters of the ether pulse theory relied mainly on the power of the rays to penetrate metal foil, and on the absence of electrostatic deflection. The latter objection was removed by the experiments just described, while the former vanished when it was shewn that the particles were not atoms but something many times smaller in size. In any case we now know that the objection was entirely illusory, though very reasonable at the time, as we have now direct evidence that even atoms such as those of

helium can under similar circumstances pass through solid matter without producing perforations.

By observing the combined action of an electric and a magnetic field upon the path of the particles it is possible to determine their velocity, and the ratio of the mass of the particle to the charge upon it.

45. Motion of a charged particle under the action of a magnetic field. Let us assume that we have a stream of electrified particles moving with a velocity v along some direction OX . If each particle carries a charge e the total transference of electricity across any cross section of OX is ev per second, which is electrically equivalent to a current ev in the direction OX . This current will produce a magnetic field at a point in the neighbourhood, and conversely will be acted upon by a mechanical force if placed in a magnetic field.

The mechanical force on a current element of strength ids in a magnetic field of strength H is equal to $Hids \sin \theta$, where θ is the angle between the direction of the current and the direction of the magnetic field, and acts in a direction perpendicular to these two directions. Putting the current i in the form dq/dt where q is the transference of electricity

$$\text{the mechanical force} = \frac{Hdq}{dt} ds \sin \theta.$$

Considering the case of a single particle, dq is the charge carried by the particle, while ds/dt is the velocity with which the particle is moving. Thus the mechanical force on the particle due to the magnetic field is equal to

$$Hev \sin \theta (36)$$

in a direction at right angles to the velocity and the magnetic field.

The magnetic equivalence of a moving electric charge to a current was demonstrated experimentally by Rowland. A large insulating disk was furnished near its circumference with a number of conducting studs which could be charged to a known value by induction from a neighbouring charged plate. On

rotating this disk at a rapid rate a magnetic field was produced, which was found to be, within the limits of experimental error, the same as that which would have been produced by a current of strength qv where q is the total charge on the studs, and v their velocity, if moving in a circuit coinciding with the path of the studs.

Suppose for simplicity that the particle is projected at right angles to the magnetic field (the mechanical force in this case is equal to Hev). Since the mechanical force is always at right angles to the path of the particle the speed will remain unaltered. Let ρ be the radius of curvature of the path of the particle under the action of the field, and m its mass. The centrifugal force is equal to $\frac{mv^2}{\rho}$ and for equilibrium this must be balanced by the mechanical force due to the field. Hence

$$\frac{mv^2}{\rho} = Hev,$$

$$\rho = \frac{m}{e} \frac{v}{H} \cdot \cdot \cdot \cdot \cdot \cdot \quad (37)$$

As v is constant the radius of curvature is constant, that is, the particle describes a circle of radius $\frac{m}{e} \frac{v}{H}$ in a plane at right angles to the magnetic field.

If the velocity of the particle has a component parallel to the magnetic field this component will remain unaltered since there is no mechanical force acting on the particle along this direction, and the particle thus moves forward through equal distances in equal times along this line, while at the same time describing a curved path around it. Its path is thus some kind of spiral, the axis of which is parallel to the field. If θ is the angle between the direction of projection of the particle and the field we have

$$\frac{mv^2}{\rho} = Hev \sin \theta,$$

$$\rho = \frac{mv}{eH \sin \theta} \cdot \cdot \cdot \cdot \cdot \cdot \quad (38)$$

Since v and θ are constant ρ is constant and the path of the particle is a helix wound on a circular cylinder with its axis

parallel to the magnetic field and of radius $r = \rho \sin^2 \theta = \frac{mv \sin \theta}{eH}$.

When $\theta = \frac{\pi}{2}$ this helix contracts into a circle, the case we have already considered.

In the general case, when the field is not uniform, the particles will describe spirals of varying amplitudes about the lines of the magnetic field.

46. Motion of a charged particle under the joint action of electric and magnetic forces. If the particle is moving in an electric field of intensity X it will experience a force equal to Xe , and in the absence of any resisting medium, as for example when it is freely moving through a vacuum, it will have an acceleration of Xe/m in the direction of the electric field.

If there is also a magnetic field it has, as we have seen, an acceleration $H (e/m) \sin \theta$ due to the magnetic field H , and its actual acceleration at any instant is the resultant of these two. The path will evidently depend on the magnitudes of the velocity, the magnetic, and the electric fields, and on their relative directions. The general solution has been obtained. It will, however, be sufficient to consider the cases which are of practical importance.

CASE 1. The magnetic and electric fields act in the same line and the particle is projected at right angles to them. In this case since the acceleration due to the magnetic field is at right angles to the field while that due to the electrostatic field is parallel to the field the two accelerations are at right angles to each other, and similarly the two deflections produced will also be at right angles to each other and to the path of the particle. Hence if the original velocity of the particle is so great that we may neglect the small change in its speed produced by the action of the electrostatic field on the particle, the deflection of the particle produced by one of the fields in the direction in which it acts will be independent of the action of the other. The final displacement of the particle will thus be the resultant of the two displacements which each would produce separately. For

example if the fields are arranged with their lines of force vertical, the electric field if acting alone would produce a vertical displacement of the particle of, say, y cm., while the magnetic field alone would produce a horizontal displacement of, say, x cm. Then if they are both acting together the particle will by their joint action be displaced to a position the co-ordinates of which will be x, y . This is the arrangement most generally employed in experimental work.

CASE 2. *The electric and magnetic fields are at right angles to each other, and the particle is projected at right angles to the two fields.* In this case the mechanical force due to the two fields acts along the same line, and at right angles to the original velocity v . Thus the resultant force on the particle is equal to

$$Hev - Xe$$

assuming that the fields are so arranged that the forces are in opposite directions and acts along the direction of the lines of force of the electric field. This force will be zero if

$$Hev - Xe = 0$$

or

$$v = X/H. \quad . \quad . \quad . \quad . \quad . \quad (39)$$

The motion of the particle will in this case be unaltered by the joint action of the electric and magnetic fields, an important relation, which has often been used to determine v .

CASE 3. *A charged particle, initially at rest, is exposed to the joint action of electric and magnetic fields at right angles to each other.* Suppose the electric and magnetic fields coincide with the axes of X and Z respectively. The particle being charged will begin to move in the direction OX . As soon, however, as it has acquired a velocity it will be acted upon by the magnetic field, and its path will therefore be modified.

Suppose that at any instant the component of its velocity parallel to the electric field is dx/dt . There is then a mechanical force acting on the particle at right angles to the magnetic field and to the electric field, that is, in the direction of OY , and equal by (36) to $Hedx/dt$. Hence

$$m \frac{d^2y}{dt^2} = He \frac{dx}{dt} \quad . \quad . \quad . \quad . \quad . \quad (40)$$

The electric force along OX is equal to Xe , and there will also be a mechanical force in this direction due to the magnetic field equal to $Hedy/dt$, where dy/dt is the component of the velocity of the particle along OY . Hence

$$m \frac{d^2x}{dt^2} = Xe - He \frac{dy}{dt} \dots \dots \dots (41)$$

The solution of equations (40) and (41) is

$$\left. \begin{aligned} x &= \frac{X}{\omega H} (1 - \cos \omega t) \\ y &= \frac{X}{\omega H} (\omega t - \sin \omega t) \end{aligned} \right\} \dots \dots \dots (42)$$

where $\omega = \frac{He}{m}$.

These are the equations to a cycloid, the curve traced out by a point on the circumference of a circle when the latter

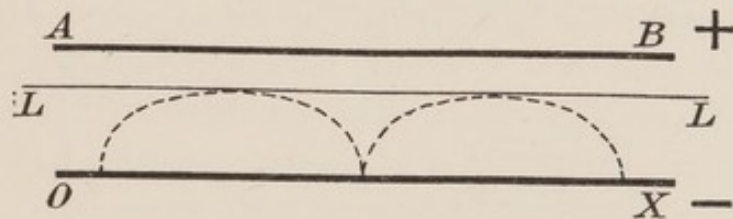

Fig. 38

rolls along a straight line. The path therefore consists of a series of loops as shewn in Fig. 38, where the electrons are supposed to be liberated from the surface of the plate OX . It is obvious that the particle can never reach more than a certain distance in the direction of the electric field, and cannot penetrate beyond the plane LL which is the common tangent to the curves. Since the minimum value of $\cos \omega t$ is -1 this

maximum distance is equal to $\frac{2X}{\omega H}$ or $\frac{2X}{H^2} \frac{m}{e}$.

Thus if AB and OX are two parallel plates, and an electric field of strength X is established between them, while a uniform magnetic field H is applied at right angles to the plane of the paper, then if ions are formed on the surface of the negative plate OX , either by the action of ultra-violet light, or by raising it to incandescence or otherwise, no charge will be received by the

similarly pierced but with a still finer slit is placed at B some distance from A . A very fine flat pencil of rays is thus obtained which in the absence of any deflecting fields falls on a fluorescent screen of barium platino-cyanide or powdered willemite at the far end of the tube.

The electric field is applied by two parallel plate electrodes J , K , their planes being parallel to the path of the rays. The lower plate is earthed while the upper is charged to a suitable potential by means of a large number of small accumulator cells. The field can thus be calculated if the distance between the plates is known. The deflection produced by the field on the negative particles of the rays is in the direction of the field, that is, in the plane of the paper.

The magnetic field is applied by a small electromagnet placed with its poles at right angles to the plates J , K . Since the magnetic deflection is at right angles to the magnetic field the magnetic deflection is also in the plane of the paper.

Suppose now that both the magnetic and the electric fields are uniform and coterminous being applied over a short length LM of the path of the particles. The two fields produce deflections in the same straight line and by properly adjusting the sign and intensity of the electric field these two deflections may be made to neutralize each other, a condition the fulfilment of which can be ascertained by the return of the spot of light on the fluorescent screen to its undeflected position. Under these conditions we have by (39)

$$v = X/H.$$

To find e/m for the particles we must now measure the deflection produced either by the magnetic or the electric field acting alone. Taking the former case the path of the particles while in the uniform field is bent into the arc of a circle of radius ρ given by

$$\frac{1}{\rho} = \frac{He}{mv}.$$

On emerging from the field at K the particles will continue to move along the tangent to the circle at K . The angle PNO through which the rays are deflected is by the geometry of the figure equal to the angle LCM , that is, to LM/ρ . Thus

$\frac{LM}{\rho} = \frac{OP}{ON}$ from which ρ can be determined when the deflection and the dimensions of the apparatus are known. Since the magnetic field and the velocity v are both known, e/m can be calculated.

The electrostatic deflection can also be calculated. The acceleration produced in this case is parallel to the field, that is, perpendicular to LO and equal to Xe/m . If the time during which the particle is in the field is t this produces a velocity $X(e/m)t$ or $\frac{Xe}{m} \frac{LM}{v}$ in a vertical direction. On leaving the field the particle moves with these two velocities. Hence if P' is the deflected position of the rays OP'/OM is equal to the ratio of the horizontal to the vertical velocity, that is, to

$$\frac{Xe}{m} \frac{LM}{v^2}, \quad \dots \dots \dots (44)$$

which can be evaluated for e/m since the field X and the velocity v are known.

It is obvious that under the conditions of the experiment neither of the fields can be perfectly uniform owing to the disturbances near the edges of the plates and the poles. A correction can be applied as follows.

Since the curvature of the path is small we have approximately, if x is the co-ordinate of the particle measured along the undisturbed path LO and y the co-ordinate at right angles to it, $\frac{1}{\rho} = \frac{d^2y}{dx^2}$. Hence

$$\begin{aligned} \frac{d^2y}{dx^2} &= \frac{He}{mv}, \\ \therefore OP &= \frac{e}{mv} \int_0^{BP} \left[\int_0^x H dx \right] dx. \quad \dots \dots (45) \end{aligned}$$

Similarly the electric deflection OP'

$$= \frac{e}{v^2 m} \int_0^{BP} \left[\int_0^x X dx \right] dx. \quad \dots \dots (46)$$

If these integrals are evaluated, which can be done when the distribution of the two fields is known we have two equations for determining e/m and v .

48. **Kaufmann's method of determining e/m .** A somewhat different method was used by Kaufmann. In order to obtain a very uniform magnetic field of calculable value he enclosed the whole of the path of the cathode rays from the limiting aperture to the screen in a uniformly wound solenoid (Fig. 40). The magnetic observations could thus be made with considerable accuracy. Instead of measuring the electrostatic deflection of the rays he assumed that the energy of the cathode particles was that due to a fall through the whole difference of potential between the cathode and the anode, that is, to Ve where V is the difference of potential between the electrodes of the discharge tube.

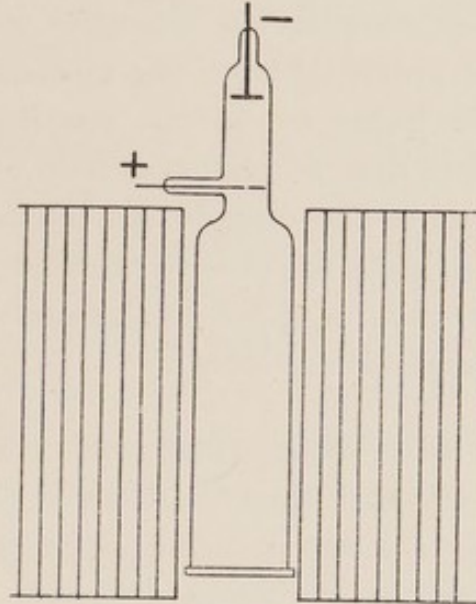

Fig. 40

V was measured by an electrostatic voltmeter. This assumption implies that the effect of the collisions of the rays with the residual gas is negligible. To test this point experiments were made for many different pressures of the gas in the tube. These different experiments were found to yield exactly the same results and hence, since the collisions would be relatively more frequent at high pressures than at low, Kaufmann's assumption seems justifiable. Hence we may write $\frac{1}{2}mv^2 = Ve$;

$$v^2 = 2V \frac{e}{m} \dots \dots \dots (47)$$

A very careful investigation of the magnetic field was made and the integral (45) evaluated. In this way Kaufmann obtained a value for e/m of 1.77×10^7 absolute e.m.u. per gm.; a value very near the mean of the best recent observations.

49. **The magnetic spectrum.** Since the velocity of the cathode particles depends on the difference of potential between the ends of the tube it will vary with the conditions of the experi-

ment. In an ordinary discharge tube run by an induction coil the cathode rays are far from homogeneous since the potential difference between the terminals of a coil is not uniform but rises rapidly, at each interruption of the current, from zero up to a certain maximum. Hence the cathode rays will contain particles having velocities corresponding to varying differences of potential from the minimum value necessary to produce the discharge up to the maximum value given by the coil. On applying a magnetic field, therefore, the single spot of light due to the undeflected beam will be drawn into a line at right angles to the lines of the field, each point of which will correspond to rays of a definite velocity. This effect is often known as a *magnetic spectrum*.

50. **Numerical value of e/m .** Though the values of v vary with the conditions of the experiment, the values obtained for e/m are invariably the same. Many experiments have now been made using different electrodes and different gases at different pressures. Experiments have also been made with other sources of electrons, such for example as the β -rays given off by radioactive bodies, the electrons emitted by heated oxides, and by the action of ultra-violet light on metals, all of which we shall consider later. In every case, however, the value of the ratio e/m is within the limits of experimental error the same. It is thus independent of all conditions and is a universal constant. A few of the many results obtained are

TABLE III
 e/m for electrons from various sources

OBSERVER	SOURCE OF ELECTRONS	e/m in e.m.u. per gm.
Kaufmann	Cathode rays	1.77×10^7
Classen	"	1.774×10^7
"	Hot lime	1.776×10^7
Bestelmeyer	"	1.766×10^7
Malassez	Slow β -rays from radium	1.769×10^7
Woltz	" "	1.767×10^7
Bucherer	" "	1.763×10^7
Gmelin	Zeeman effect (mean value)	1.771×10^7

collected in Table III. It will be seen that the value of e/m does not differ appreciably from 1.77×10^7 e.m.u. per gm. which is the value we shall assume in this volume. Assuming that e has the value 1.57×10^{-20} e.m.u. electronic charge the value of m is 8.9×10^{-28} gm. or about 1/1800 that of the hydrogen atom. The cathode particles are thus very small compared with the smallest atom hitherto known.

51. Direct measurement of the velocity of cathode rays.

The velocity of the cathode rays has also been determined by direct experiment by Wiechert. The principle of the method is as follows. The cathode rays from a cathode C (Fig. 41) fall normally on a hole in a screen A , and through another hole in a screen A' on to a narrow fluorescent plate S . The rays are then deflected by a permanent magnet M placed near the cathode so that they all fall on the solid part of A , the screen S

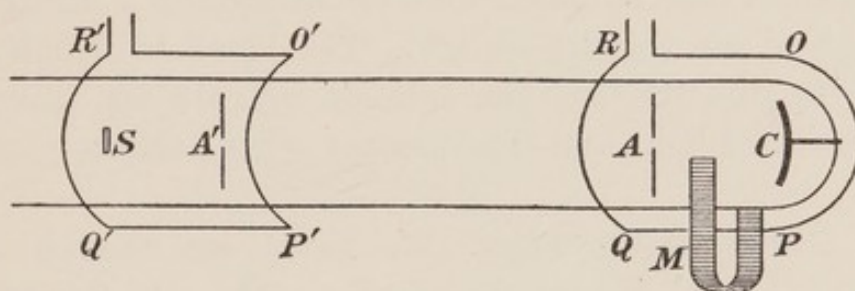

Fig. 41

in consequence being dark. A circuit $OPQR$ carrying a rapidly alternating current such as that obtained by the discharge of a condenser is brought near AC , thus producing a rapidly alternating magnetic field. This will set the beam of rays swinging like a pendulum at right angles to the field, and if the force is sufficiently great the oscillations will be sufficiently large to reach to the hole in A . Thus rays will pass through intermittently, and the screen S will again become bright.

A second circuit $O'P'Q'R'$ is now brought up near $A'S$ carrying the same alternating current as that in the circuit $OPQR$. If the time taken by the rays to pass from A to S is zero the two magnetic fields will produce at any instant fields of the same sign and intensity; hence the rays between A' and S will suffer the same deflection as between C and A and

will be deflected off the screen which will thus be always dark. If, however, the time taken by the rays to pass from A to S is such that the current has changed its phase by one-quarter of a period during that time there will be no current in $O'P'Q'R'$ when the rays reach A' . Thus the rays will suffer no further deflection and the screen will become bright.

Thus the screen will become bright if the time taken for the rays to describe a distance AS is equal to the time taken for the current in the wires to change by one-quarter of a whole period, that is, to $\frac{1}{4}L/c$, where c is the velocity of light and L the wave length of the current vibrations. The latter can be determined experimentally by any of the methods for determining wave lengths used in wireless telegraphy. Hence finally

$$v = AS \frac{4c}{L}.$$

The values thus obtained were of the order 3×10^9 or about one-tenth of the velocity of light. This result is of importance as proving directly that the cathode rays do not travel with the velocity of light and thus are not ether pulses.

52. The positive rays. We have seen that if a solid obstacle is placed in a discharge tube within the Crookes dark space it casts a shadow not only on the further walls of the tube but also on the cathode itself. This indicates that there are in the tube particles moving toward the cathode and, therefore, presumably positively charged. If a hole is made through the cathode normal to its surface these rays can be seen streaming through and causing phosphorescence in the residual gas behind the cathode. This phosphorescence is generally quite distinct in colour from that produced in the same gas by the cathode rays. In helium, for example, the path of the cathode rays is marked by a bluish light while that of the *Kanalstrahlen*, or *positive rays* as they are now called, is marked by a red glow.

The positive rays are now known to consist of positively charged molecules of the various gases in the discharge tube, moving with considerable speeds under the intense electric

field of the discharge. Their investigation proved a matter of great difficulty owing partly to the very intense ionization which they produce in the residual gases of the discharge tube, and partly owing to the secondary radiations to which they give rise. When a positive particle in the ray collides with a gas molecule, since the two are of comparable mass, it is frequently not the original particle but the molecule struck which continues the course of the rays, and this molecule may or may not be charged. Unless these effects are eliminated very curious and misleading results may be obtained. These effects may obviously be diminished by working at very low pressures so as to reduce the number of molecules of residual gas. On the other hand if the exhaustion is made very complete

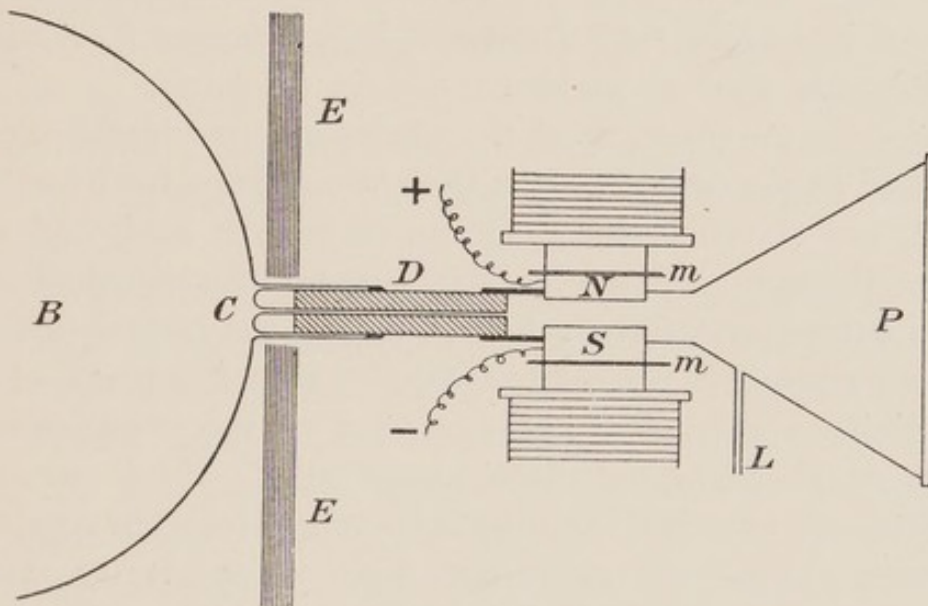

Fig. 42

it becomes a matter of very serious difficulty to obtain a discharge through the gas at all, and accurate measurements become impossible.

53. Thomson's experiments on the positive rays. Professor Sir J. J. Thomson was eventually after considerable research able to overcome these difficulties. One form of his apparatus is shewn in Fig. 42.

The discharge takes place in a large bulb *B* of considerable size, it having been found that a discharge takes place much

more readily at very low pressures if the discharge tube is of considerable volume. At one time bulbs of 40 or 50 cms. diameter were employed but it has since been found that a diameter of 20 cm. is sufficient for the purpose. The cathode *C* consists of an aluminium rod with a rounded end, pierced by a very fine copper tube. This tube which was generally less than 1/10 mm. in diameter, and in some experiments as little as 1/100 mm. diameter, was made by drawing down ordinary narrow copper tubing through a draw plate. In this way when the discharge is passing an exceedingly fine pencil of positive rays is obtained. It is obvious that with a tube as narrow as 1/10 mm. any stray magnetic field will deflect the charged particles constituting the rays against the walls of the tube where they will be lost. To prevent this the copper tube is enclosed in a thick tube *D*, of soft iron. Screens *E*, *E* also of soft iron are used to protect the main discharge.

Owing to the strength of the discharge considerable heat is produced at the cathode. It is therefore surrounded by a water jacket, not shewn in the diagram, to keep it cool, and so to protect the numerous sealing wax joints in the neighbourhood.

The narrowness of the tube perforating the cathode serves a double purpose. It not only produces a very fine pencil of rays thus giving a very clear luminous spot on the phosphorescent screen or photographic plate placed at *P*, but it serves to separate very effectively the discharge tube *B* from the measuring apparatus, or camera as we may term it for brevity. Owing to the fineness and length of the tube which is the only connection between the two, diffusion takes place very slowly through it, especially at the low pressures used. If the camera is continuously exhausted through the side tube *L*, by a large tube of charcoal kept cool in liquid air, it is possible to have the gas in the camera at a considerably lower pressure than that in the discharge tube. Thus we can keep the pressure in the discharge tube at the value most suitable for the discharge, and at the same time maintain the vacuum in the measuring part of the apparatus so low that the positive rays are not seriously affected by the presence of residual gas. To keep the pressure in the discharge tube constant, fresh supplies of

the gas under experiment are introduced at a very slow rate through a side tube.

To measure the velocity and the ratio of the mass to the charge for these particles, the same principles are employed as in the case of the cathode rays, the method adopted being that in which the two fields are applied in the same direction. The method of doing this, which is rather ingenious, is indicated in the figure. The pole pieces *N* and *S* are let into the sides of the chamber, the joints being made gas tight with sealing wax. They are electrically insulated from the core of the large electromagnet by thin strips of ebonite *m, m*. By connecting the magnetic pole pieces to the opposite poles of a large battery of small accumulators they can thus be used to apply the electrostatic field also.

Since the two fields are parallel the displacements they produce in the path of the rays will be at right angles to each other, the electrostatic displacement being in the plane of the diagram, the magnetic displacement at right angles to it.

In the final form of the apparatus the fluorescent screen *P* was replaced by a photographic plate. The positive rays affect the plate at the point where they strike it in the same way as light, so that on developing the plate the points struck by the particles appear as black spots or lines on the clear glass. The plate can then be placed under a travelling microscope and the deflections measured with accuracy.

The magnetic and electric displacements of a moving charged particle under the conditions of the experiment have already been calculated (§ 47). Taking the approximate formulae of § 47, in which the fields are assumed to be constant over the whole of their extent, we should have, if *x* and *y* are respectively the electric and magnetic displacements of the particle,

$$x = Dd \frac{XE}{mv^2} ; \quad y = Dd \frac{HE}{mv} ,$$

where *D* is the distance of the photographic plate from the field, *d* the length of the path of the particle in the field and *E*

and m its charge and mass. Taking the accurate formulae (45), (46), we have

$$x = \frac{E}{mv^2} \int_0^{OP} \left[\int_0^x X dx \right] dx ; \quad y = \frac{E}{mv} \int_0^{OP} \left[\int_0^x H dx \right] dx.$$

The values of these integrals depend only on the applied field between the plates and the geometry of the apparatus. Hence for a given tube we can write them in the form

$$\left. \begin{aligned} x &= k_1 \frac{EX}{mv^2} \\ y &= k_2 \frac{EH}{mv} \end{aligned} \right\}, \quad \dots \dots \dots (48)$$

where k_1 and k_2 are constants for a given apparatus and can be evaluated experimentally if required. Combining these equations we have

$$\frac{y}{x} = \frac{k_2}{k_1} \frac{H}{X} v, \quad \dots \dots \dots (49)$$

$$\frac{y^2}{x} = \frac{k_2^2}{k_1} \frac{H^2}{X} \frac{E}{m} \dots \dots \dots (50)$$

Thus if the two fields are maintained at a constant value throughout the experiment y/x is a measure of the velocity of the particle and y^2/x a measure of the ratio of the charge to the mass. The values of x and y can be obtained by measuring the co-ordinates of the deflected spot on the photographic plate.

54. Positive ray parabolas. Let us consider the matter in the light of equations (49) and (50).

If all the particles had the same velocity and the same value of E/m they would all be deflected to the same extent in the two fields, and the deflected rays would strike the screen in a single spot. Let us consider the production of the particles in the discharge. Some will be formed near the anode and will thus fall through the whole difference of potential between the cathode and the anode. Their energy will thus be VE where V is the difference of potential between the electrodes, and they will reach the cathode with a velocity v given by

$$\frac{1}{2}mv^2 = VE.$$

This is obviously the maximum velocity the particles can acquire. Those formed nearer the cathode will only fall through a fraction of this potential and will approach the cathode with smaller velocities. Hence the bundle of rays will contain particles of all velocities up to a certain maximum which will be a constant for the tube. Thus on applying the fields the single undeflected spot of light will be drawn out into a band on applying the two fields. It is obvious from equation (50) that all particles whatever their velocity for which the value of E/m is the same will lie on a single curve given by

$$y^2/x = \text{constant}$$

which is the equation to a parabola. If the stream of rays entering the two fields contains sets of particles for which the values of E/m are different, they will be sorted out into a series of parabolas, each of which corresponds to some definite value of the ratio E/m .

Again since the electric deflection x is given by $x = k_1 \frac{EX}{mv^2}$, and since the maximum value of v is given by $\frac{1}{2}mv^2 = VE$ the smallest possible deflection we can obtain is given by

$$x = k_1 \frac{X}{V},$$

and is constant for all the particles no matter what their mass and charge, if the deflecting field and the potential across the tube remain the same. Thus all the parabolas will stop abruptly at a line drawn parallel to OY at a distance $k_1 \frac{X}{V}$ from it.

If the magnetic field acts in the same direction throughout the experiment only one branch of each parabola will be obtained. By reversing the field half way through the experiment the direction of the deflection can be reversed and thus the lower half of the parabola can be obtained on the plate. This is always done in practice as it increases the accuracy with which the displacement can be measured. Thus on development the plate should have an appearance such as that shewn in Fig. 43, which represents the case of two sets of particles.

Two typical photographs taken by Sir J. J. Thomson by this

method are shewn in Fig. 44 (*a* and *b*). It will be seen that the single undeflected spot is drawn out by the action of the

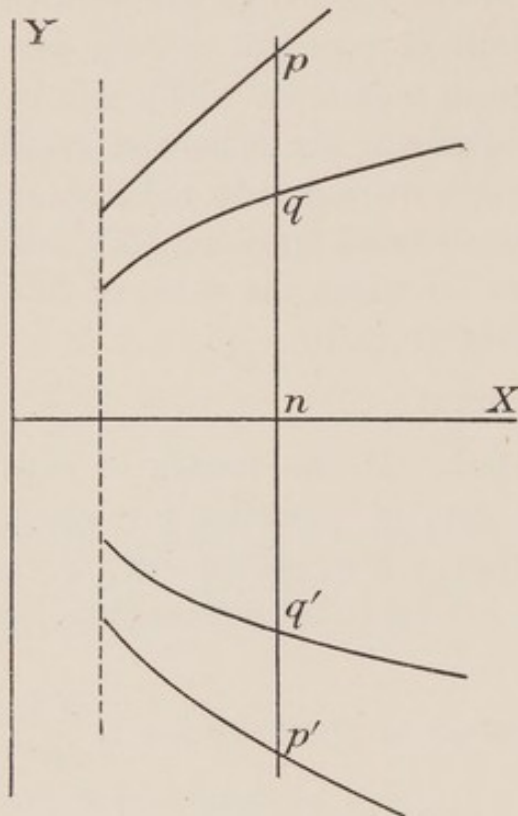

Fig. 43

fields into a series of curves one above the other which can be shewn by measurement to be parabolas. The curves in the lower half of the diagram are produced by reversing the magnetic field half way through the exposure, as already explained. It will be seen that they reproduce exactly the theoretical curves of Fig. 43.

It is evident from equation (50) that the most deflected parabolas correspond to the greater values of E/m , that is, assuming all the particles to carry the same charge, to the lighter particles. Evaluating the constants it was found that the value of E/m for the most deflected parabola of all the values was almost exactly 10^4 . This as we have seen is the value of this ratio for the hydrogen ion in electrolysis. The most deflected parabola corresponds therefore to a hydrogen atom carrying a single electronic charge. To find the value for any other parabola we may proceed as follows. Draw any ordinate cutting the two parabolas (Fig. 43) in p, p' and q, q' and the axis of X in n . Then since x is the same for all points on the ordinate we have

$$\begin{aligned} \frac{(pp')^2}{(qq')^2} &= \frac{pn^2}{qn^2} = \frac{y_1^2/x}{y_2^2/x} \\ &= m_2/E_2 \div m_1/E_1. \quad \dots \quad (51) \end{aligned}$$

If we can assume that the two sets of particles carry the same charge the ratio $\frac{pp_1^2}{qq_1^2}$ measures the ratio of the masses of the two particles, or in other words if the outer parabola is that of

the hydrogen atom, the ratio gives the molecular weight of the particle forming the parabola.

The matter is in general not quite so simple as this, since it is found that the particles in the positive rays may carry charges which are greater than the unit charge, that is, they may be atoms or molecules which have lost more than one electron. If they have lost n electrons the value thus deduced will be $1/n$ th of the molecular weight. The method of procedure and the nature of the results obtained will be clear from the example given in Table IV which refers to a photograph taken with atmospheric nitrogen in the tube. The first column gives

TABLE IV

Atmospheric nitrogen. Potential across discharge tube, 30,000 volts; current through magnet, 3.5 amperes; potential difference between plates, 200 volts.

d	m/E	NATURE OF PARTICLE	
7.2	200	Hg +	Mercury atom with single charge
10.3	100	Hg + +	Mercury atom with two charges
12.4	67	Hg + + +	Mercury atom with three charges
15.4	44	CO ₂ +	Molecule of carbon dioxide
16.5	39	A +	Argon (40) with single charge
19.4	28	N ₂ +	Nitrogen molecule with single charge
23.1	20	Ne +	Neon with single charge
25.6	15.9	O +	Oxygen atom with single charge
27.6	14	N +	Nitrogen atom with single charge
30.0	12	C +	Carbon atom with single charge
38.7	7	N + +	Nitrogen atom with double charge

the distance pp' between the two limbs of the same parabola (which are obtained as already explained by reversing the magnetic field in the middle of the exposure), the second column the value deduced for the ratio m/E , the value for the hydrogen parabola being taken as unity. It therefore gives the molecular weight of the particles forming the parabola assuming them to have the unit charge. The last column gives the origin assigned to the particles, a double electronic charge being expressed by two plus signs (+ +), and a triple charge by three. It will be seen that the rays contain atoms and

molecules of nitrogen together with other atmospheric gases such as argon and neon, carbon dioxide and carbon, probably from the grease used on the taps, mercury vapour from the pump, and oxygen, probably due to moisture. The hydrogen parabola has been deflected off the picture altogether.

It will be noticed that in several instances it is necessary to suppose that the particles carry twice or three times the unit charge. In the case of mercury as many as eight units of charge are occasionally met with giving a parabola the value of m/E for which is $200/8$ or 25 . The parabolas formed by the multiple charged atoms are always less distinct than those due to the same carriers with single charges. This result is often of value in enabling us to determine the origin of a given parabola, for example to distinguish between a singly charged atom of nitrogen and a doubly charged molecule of carbon monoxide, which would give the same value for m/E . In some cases however the uncertainty cannot be cleared up except from a consideration of the gases most probably present in the tube under the conditions of the experiment.

55. Negative parabolas. In some of the positive ray photographs parabolas are seen in the opposite quadrant to those we have just been considering. These give the same values for E/m as those in the first quadrant but it is obvious that the particles must carry negative instead of positive charges, since both the electrostatic and the electromagnetic deflections are in the opposite direction to those for the positive particles. Since these particles have come through the cathode it is also evident that they had a positive charge while in the discharge but that this charge had been not only neutralized but reversed before reaching the deflecting fields, that is, during their passage along the fine copper tube. It must be remembered that the positive rays produce ionization in the residual gas through which they pass and hence are surrounded by negative electrons. If the positive particle acquires two of these during its passage down the tube it will have a unit negative charge when it emerges and hence will give rise to a negative parabola. If only one is taken up it emerges uncharged and is



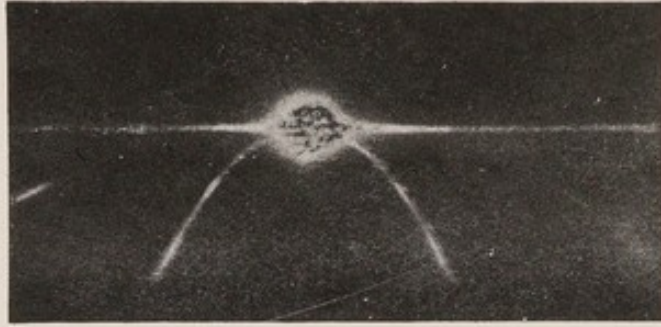

Fig. 44 *a*



Fig. 44 *b*

[To face page 107

then undeflected by the fields. This is probably the fate of the majority of the particles in the rays since there is always an undeflected spot on the plate as shewn in the photographs in Fig. 44, which is generally much more intense than any of the parabolas. The negative parabolas are most marked in the case of oxygen and the halogens, as we should perhaps expect, these elements being markedly electro-negative in character. Strangely enough the phenomenon also occurs with hydrogen. It has never been observed with nitrogen or helium.

56. Positive ray analysis. Since the molecules and atoms of the gases in the tube record, so to speak, their own molecular or atomic weight on the plate the method can be employed to analyse a given gas, at any rate qualitatively. For this purpose it is far more sensitive than the spectroscopic method which has hitherto been the most delicate known. The sensitiveness of the method is demonstrated by the following facts. Photographs taken with atmospheric argon in the tube at a pressure of $1/300$ mm. of mercury always shewed the helium parabola quite distinctly. The volume of the discharge tube was about two litres so that the volume of argon under experiment would have a volume of about $1/100$ c.c. at atmospheric pressure. This is the amount present in 1 c.c. of air. We can thus detect the helium present in a single cubic cm. of ordinary air. According to Ramsay this is of the order of four millionths of a cubic cm. The experimental difficulties are, however, very great and the method is not likely to come into general use.

It has however already proved its value in giving evidence of two new gases; one resembling neon in all its properties but with an atomic weight of 22, the other a gas of atomic or molecular weight 3, which may be either a new element or an allotropic form of hydrogen corresponding to ozone.

The method may also have applications in the study of chemical decomposition. Owing to the fact that the particles register themselves on the plate in a time which is generally considerably less than a millionth of a second, very unstable combinations of atoms may be found among the particles in

the positive rays. Thus, if the tube contains methane, parabolas are found representing not only methane itself and its constituents carbon and hydrogen but also the intermediate stages CH , CH_2 and CH_3 .

Only certain elements seem capable of entering into the positive rays. The metals are noticeably absent. Mercury always gives well-marked parabolas if present even in minute traces, and nickel has been obtained when nickel carbonyl is introduced into the tube, but only with much difficulty. The other volatile metallic compounds give no trace of their metallic constituent among the positive ray parabolas produced.

57. Electrical method of measuring positive rays. Since the particles carry positive charges it is possible to detect them electrically. For this purpose the screen P is replaced by a thick brass plate B (Fig. 45) in which a parabolic slit SS is cut at some distance from the centre. A small Faraday

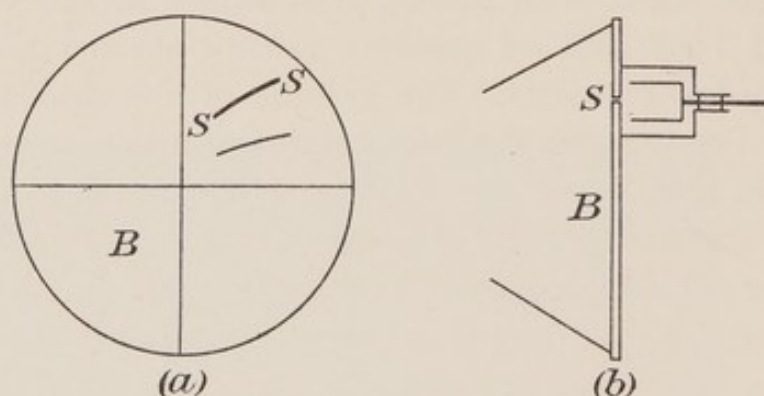

Fig. 45

cylinder is fastened behind the slit as shewn in Fig. 45 *b*, the inner cylinder being connected to a sensitive electroscope. Keeping the electric field constant the magnetic field is gradually increased so that each parabola in turn, in moving out from the axis of X , passes over the slit in the plate. The passage of each parabola across the slit is marked by a deflection in the electroscope. If the current is measured the relative number of particles in each parabola can be determined. The value of m/E can be deduced from the corresponding values of the fields, remembering that the value of y^2/x is now fixed by the position of the slit. If the slit is made sufficiently narrow, the

parabolas due to particles differing by only one or two units of atomic weight can easily be distinguished.

The results obtained shew that the photographic method may be very misleading if the relative darkness of the various lines is taken as a criterion of the relative number of particles going to form the parabolas. For some unexplained reason the atoms of the elements of low atomic weight produce far more effect on a photographic plate than an equal number of atoms of a heavier element. Thus the hydrogen parabola may often be the most intense on the plate although the number of hydrogen atoms in the rays is shewn by the electrical method to form no more than one per cent. of the whole.

58. Secondary effects. Lines which are not parabolic are sometimes found on the plates. These are generally due to particles which have lost their charge while actually in the two fields. Their deflection, therefore, has a value intermediate between that of a charged and an uncharged particle. These secondary effects can generally be recognized as such by repeating the experiments at a slightly lower pressure, when owing to the smaller number of molecules available for collisions they either disappear or at any rate alter their appearance or position. Unless they are carefully watched for they are apt to give rise to misleading results.

CHAPTER VIII

EMISSION OF ELECTRICITY BY HOT BODIES

59. **Loss of charge from a hot body.** The fact that heated bodies are unable to retain electric charges has been known for nearly two centuries. Thus it was found that a red-hot iron ball was unable to retain a positive charge but would retain a negative one, while at higher temperatures still it was unable to retain a charge of either sign. The early experiments were not made under very definite conditions and most of our knowledge of the phenomena is due to experiments made since 1900, and very largely to the work of O. W. Richardson, who has given the name *thermionics* to this branch of the subject. The current from a heated body is thus known as the *thermionic current*, while the carriers by which the discharge is carried are known as *thermions*. As we shall see the negative carriers are negative electrons, while the positive carriers are positively charged atoms. The terms are however very convenient, and will be retained.

The phenomena are in general very complex, the current depending on the nature and pressure of the surrounding gas, and on the nature and previous treatment of the heated substance. To simplify matters as far as possible we will take the case of a metallic wire which has been carefully treated to remove impurities, heated in a high vacuum so as to eliminate all effects due to the presence of gas. This effect can be studied conveniently with the apparatus shewn in Fig. 46. The wire *AB* to be heated is surrounded by an outer metal cylinder *CC* which remains cool during the experiment, the whole being enclosed in a glass vessel which can be evacuated. The wire is heated by a current from an insulated battery of cells and the temperature of the wire can be estimated by measuring its electrical resistance and thus making it serve as

its own resistance thermometer. If the wire is raised to a suitable small potential a current flows from the hot wire to the cool cylinder. This current can be measured either by the electrometer method, or in many cases simply by allowing it to flow to earth through a galvanometer.

Initially with a new wire the current will flow through the tube whether the wire is negatively or positively charged shewing that thermions of both signs are emitted. If, however, the wire is kept glowing for some time and the gases evolved from the heated wire are continually removed by pumping, or better still by sweeping them out with pure oxygen, it is found that the positive current rapidly decreases and finally becomes negligibly small. The negative emission is also much reduced by this process but finally settles down to a steady value. In a good vacuum the thermionic current is independent of the

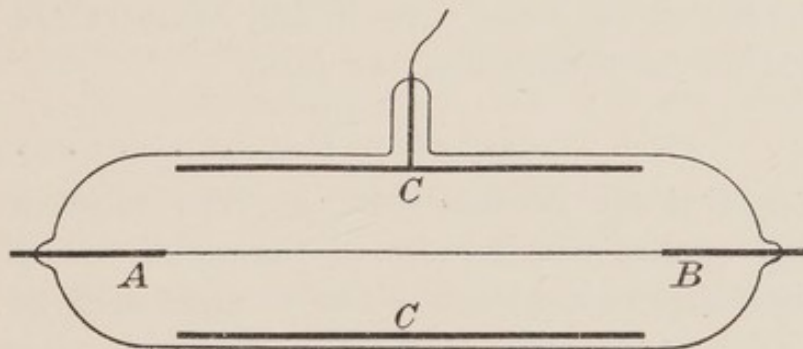

Fig. 46

potential difference if the latter exceeds a few volts. The maximum current between the electrodes under given conditions is known as the saturation current by analogy with the case of the current through ionized air. The temperature to which the wire must be raised for an appreciable current to flow depends on the nature of the substance. For platinum a temperature of about 1000° C. is required; for sodium on the other hand there is a very considerable thermionic emission at temperatures as low as 300° C.

60. Nature of the negative thermions. The value of the ratio e/m for the negative thermions emitted by a hot wire can be determined by making use of equation (43), p. 92. A measured difference of potential is applied between the hot

wire and the outer cylinder and a magnetic field is applied at right angles to the electrostatic field and parallel to the electrodes. The value H of the magnetic field which is just sufficient to prevent the thermions reaching the cold electrode is found whence

$$\frac{e}{m} = \frac{2V}{H^2 d^2}$$

where V is the difference of potential between the electrodes and d their distance apart. In this way a value of 1.6×10^7 was obtained for e/m for the negative thermions, agreeing as well as could be expected with the value of the same ratio for an electron.

61. Variation of the current with temperature. The thermionic current increases very rapidly as the temperature of the wire is increased. Richardson has found that in every case the relation between current and temperature can be represented by an equation of the form

$$i = A\theta^{\frac{1}{2}} \epsilon^{-\frac{Q}{2\theta}} \quad (52)$$

where A and Q are constants for a given substance. This relationship applies to all cases of thermionic emission, not only to that of pure metals, but also to cases such as that of carbon, and heated oxides where the current is often over a thousand times greater than that from, say, pure platinum. It thus represents a very fundamental property of thermionic emission. The relation is represented graphically by the curve of Fig. 47 which is drawn for the case of a platinum wire, the constants for which were

$$A = 6.9 \times 10^7, \text{ and } Q = 131,000.$$

For pure platinum in a good vacuum the observed current was at 1375°C. , 1.57×10^{-8} amperes per square cm. of area, and at 1500°C. , 128×10^{-8} . The calculated values using the above constants are respectively 1.49×10^{-8} and 128.5×10^{-8} . The results agree to within a few per cent.

62. Theory of thermionic emission. Let us assume that a conductor contains scattered through its volume a large

number of free electrons. There is much evidence for this view. It will, for example, enable us to account for the conductivity of the conductor by assuming that the electrons move through the metal under the action of the electric field in the same way that the gaseous ions move through a gas. The existence of these free electrons has also been postulated to explain the Peltier effect, the Thomson effect and various optical phenomena.

Let us assume also that the electrons in the metal behave like the molecules of a perfect gas. Since the spaces between the atoms are large compared with the radius of an electron this assumption seems justifiable. In this case the electrons will be moving with the kinetic energy characteristic of the temperature of the substance in which they find themselves. Their velocity will therefore increase as the square root of the absolute temperature. Thus the mean velocity of the electrons at an absolute temperature θ is given by $\frac{1}{2}mv^2 = \alpha\theta$, or

$$v = \sqrt{\frac{2\theta\alpha}{m}}, \dots \dots \dots (53)$$

where α is a constant which is the same for all gases.

While the electrons are in the metal they are perfectly free to move, except in so far as their motion is changed by collisions with atoms of the metal or with other electrons. If, however, an electron passes the surface, its charge will induce an opposite charge on the surface of the metal and work must be done to carry the electron completely away from the surface against the mutual attraction of the two charges.

The electron will succeed in escaping if its kinetic energy

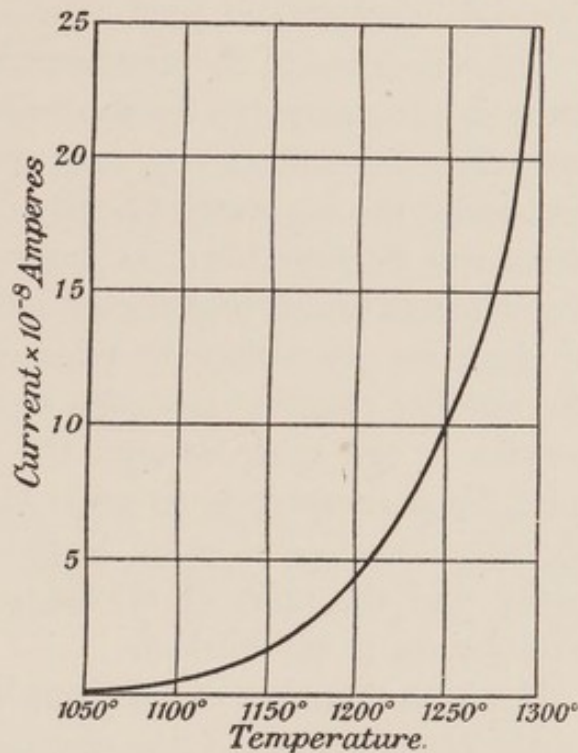

Fig. 47

in a direction normal to the surface is greater than the work w which must be done in separating the electronic charge from the surface, that is, if $\frac{1}{2}mv^2 > w$.

The velocities of the electrons will be distributed about the mean in the way given by Maxwell's distribution law. Theoretically there should at any temperature be occasional electrons possessing the necessary velocity, but at ordinary temperatures these will be very few. As however the temperature is raised the value of the mean velocity increases and hence the number of electrons possessing the minimum energy increases too, and the number escaping increases at a rapid rate. If the electrons remain in the space around the metal, they will accumulate until their pressure is so great that the number returning to the metal surface is equal to the number leaving it. We can easily find the ratio of the numbers in the two media when equilibrium is established.

If n is the number of electrons in unit volume, p the pressure of the electrons and X the electric force acting on an electron, the total force acting per unit volume must be equal to the rate of change of pressure. Thus

$$\frac{dp}{dx} = Xn.$$

But $p = \beta\theta n$ by the kinetic theory where β is a constant which is the same for all gases. Thus

$$\beta\theta \frac{dn}{dx} = Xn. \quad . \quad . \quad . \quad . \quad . \quad (54)$$

Let us integrate the equation from a plane within the metal surface to a parallel plane outside it. Then if n' is the number of electrons per unit volume in the space above the metal, N the number in the metal itself,

$$\beta\theta \log \frac{n'}{N} = - \int X dx = - w,$$

$$n' = N e^{-\frac{w}{\beta\theta}}, \quad . \quad . \quad . \quad . \quad . \quad (55)$$

where $w = \int X dx$ is the work which must be done to drag an electron out of the metal.

The number of electrons returning to the metal surface per unit area per second can easily be calculated from the kinetic theory. If we make the usual elementary assumption that the number of particles travelling in each of the six directions parallel to the faces of a cube is one-sixth of the number present in the gas, and that all the particles possess the mean velocity v for the temperature, the number n_0 striking the surface per unit area in one second will be all which are travelling normal to the surface whose distance from the surface is less than v , that is, $n'v/6$. Substituting for v its value in terms of θ we have

$$n_0 = \frac{n'}{6} \sqrt{\frac{2\alpha\theta}{m}} \dots \dots \dots (56)$$

The more correct value, taking into account the distribution of velocities among the particles, can be deduced from the kinetic theory. It differs only from the one given by a numerical constant. Hence we have

$$n_0 = Cn'\theta^{\frac{1}{2}} \dots \dots \dots (57)$$

where C is some constant for the electrons.

Now in the equilibrium state which we have been considering the number of electrons leaving the surface is equal to that returning to it. Also the number leaving the metal depends only on the conditions in the metal and not on the presence or absence of external electrons. Hence the number of electrons leaving unit area of a metal at a temperature θ is given by

$$\begin{aligned} n_0 &= Cn'\theta^{\frac{1}{2}} \\ &= C\theta^{\frac{1}{2}} N\epsilon^{-\frac{w}{\beta\theta}} \dots \dots \dots (58) \end{aligned}$$

The loss of charge is n_0e since each electron carries a charge e . This is obviously of the form of the experimental curves provided that N , the number of free electrons per unit volume of the metal, is independent of the temperature.

63. Evidence for the theory of thermionic emission. The hypothesis thus developed is capable of experimental verification in many ways. For example, since work is done in extracting the electron there should be a cooling of the wire when thermions are emitted. Thus more energy should be required to keep the wire at a given temperature if the

thermions are allowed to escape than if they are all kept in the wire by the application of a retarding electric field. This effect has been investigated by Richardson and is found to be of the magnitude demanded by the theory. The reverse effect of the production of heat in a wire when thermions are absorbed by it has also been investigated and found to agree with the theory.

A still more satisfactory proof of the theory is afforded by the measurement of the distribution of velocities among the thermions emitted by the wire. Since the velocities of the electrons in the metal are distributed according to the Maxwell-Boltzmann law, it can be shewn by the ordinary analysis of the kinetic theory that the velocities of the thermions which escape after parting with the definite amount of energy necessary to liberate them from the metal should also be distributed in the same way. This has also been investigated by Richardson by a method based on the following principle.

Let the cool electrode be maintained at a definite negative potential V . The work done by the negative electron in passing from the surface of the hot strip to the negative electrode will thus be Ve , and the electron will only succeed in reaching the electrode and imparting its charge to it if the kinetic energy $\frac{1}{2}mv^2$ is greater than Ve .

Thus the current reaching the electrode is a measure of the number of thermions whose kinetic energy perpendicular to the strip is greater than Ve . In this way the distribution of normal velocities of the thermions can be studied. A slight extension of the method can be used to measure the distribution of the velocities of the thermions in a direction parallel to the surface of the hot strip. In both cases the distribution found agreed very closely with that deduced from the Maxwell-Boltzmann law. This experiment is of great interest, not only as evidence for the hypothesis of thermionic emission but also as affording a direct proof of the validity of the assumptions of the kinetic theory of gases.

64. Discharge of negative electricity by various substances. The negative thermionic current is peculiarly sensitive

to the presence of various gases, and notably of hydrogen. The admission of a very minute quantity of hydrogen into the vacuum chamber, or even its previous absorption by the wire, is found to increase enormously the current from the wire. If hydrogen at a pressure of no more than 0.0006 mm. of mercury is admitted into the vessel the current from glowing platinum at a temperature of 1350° C. is increased no less than 2500 fold. The relation between temperature and current is still of the form given in (52) but the constants are both reduced, the value of A being reduced to 10^6 , while that of Q is reduced to 110,000. A reduction in A by itself would diminish the current. Owing however to the form of the equation the current depends principally on the value of Q , and the small reduction in Q is more than sufficient to outweigh the very considerable decrease in A .

The effect is probably due to the condensation on the platinum of a layer of hydrogen. Hydrogen is a very electro-positive element, and if we assume that the hydrogen atoms in the condensed layer are positively charged their presence will produce a field between the gas and the metal tending to assist the escape of the electrons from the metal. Less work will thus be required to extract an electron from the metal. Since Q is proportional to this work the value of Q will be decreased, as is actually found to be the case. The reduction in A is probably bound up in some way with that in Q .

In some solids the thermionic emission attains values very much greater than those obtained for pure metals in a vacuum. Thus ordinary carbon as used in carbon filament lamps gives a negative emission which even in a good vacuum may attain the order of several amperes per square cm. This effect which is known as the Edison effect has been used by Fleming to rectify the alternating currents set up in wireless receivers by the action of the wireless waves and is the principle on which the Fleming valve works. The effect in carbon is however due to impurities. Pure carbon has been found to give thermionic currents much smaller even than those from pure platinum.

The effect is also very marked in the case of certain metallic oxides, and notably those of calcium, barium and strontium.

Thus while pure platinum in air at low pressure gave a thermionic current of about 5×10^{-7} amperes per square cm. of surface, the thermionic current from lime at the same temperature was 5×10^{-2} amperes per sq. cm., and for lime in an atmosphere of hydrogen no less than 1000 amperes per sq. cm.

A strip of heated platinum coated with a small speck of lime thus furnishes a very convenient source of electrons and is known as a *Wehnelt cathode*. The strip of foil carrying the speck of oxide is heated by a current from an insulated battery, and a suitable potential is applied between the strip and the anode in the tube to give the electrons the desired velocity. Under these circumstances a pencil of cathode rays is given out by the lime, which if the pressure of the gas is not too low is made visible by a blue phosphorescence in the gas along the path of the particles. The deflection of these rays in the magnetic and electric fields can readily be demonstrated, and the value of e/m determined. As we have already seen (Table III) it is the same as that for the rays from an ordinary cathode.

The negative emission from these substances obeys the same temperature law as that from hot platinum. The value of Q is, however, generally much smaller. The great emission is therefore due to the smaller amount of energy necessary to extract an electron from the surface of these substances. The values of Q and A for a few substances are collected in Table V.

TABLE V

SUBSTANCE	Q	A
Platinum	131×10^3	6.9×10^7
Carbon	196×10^3	10^{15}
Sodium	63×10^3	10^2
Baryta	83×10^3	7×10^7
Lime	80×10^3	5×10^7
Magnesia	79×10^3	4

65. **Discharge of positive electricity.** We have already noted that if a new wire is used for the experiment there is an emission of positive electricity from the wire. This emission is noticeable at temperatures considerably lower than those

necessary to produce a measurable negative current from the wire. It is quite easily detectable at a temperature of 800° C. The exact method of formation of the positive carriers is unknown. The temperature variation of the current, however, follows the same law as that for the negative carriers, and the process may perhaps be regarded as analogous to some sort of evaporation from the surface of the metal.

The value of e/m for the positive carriers can be measured by the method already described for the negative thermions (§ 60). If the experiment is performed in a good vacuum the value of e/m for the positive carriers seems to be independent of the nature of the heated metal. Experiments made with, amongst others, platinum, carbon, gold, silver, copper, tungsten, and steel, all gave values of e/m for the positive thermions of the order of 400 e.m.u. per gm. The value of this ratio for the hydrogen ion in solution is as we have seen approximately 10^4 in the same units. Hence if the charges can be assumed to be the same in the two cases, that is, if the positive thermions are only singly charged, the mass of the thermionic positive carriers is about 25. They might thus be either atoms of sodium, which is an element universally present in small quantities, or molecules of carbon monoxide (28) a gas which also is extremely difficult to remove from discharge tubes.

In the absence of gas the positive thermionic current gradually disappears with continued heating. It is restored if the wire is removed and exposed for some days to the atmosphere of the ordinary laboratory. If, however, the tube contains gas at appreciable pressure the thermionic positive current persists and in this case a measurement of e/m for the carriers shews that they consist of the atoms and molecules of the gas in the tube.

Salts of the alkali metals give large positive emissions. In this case the carriers are always atoms of the metal in the salt; thermions having masses corresponding to the atoms of lithium, sodium, potassium and rubidium having been obtained from the corresponding salts. Certain phosphates also give large positive emissions. In this case the carriers appear to be molecules of carbon monoxide.

66. **Conductivity of flames.** If two platinum plates are placed a centimetre or so apart in a wide Bunsen flame and one of them is raised to a moderately high potential by means of a cabinet of small accumulators a current passes between the plates through the flame which is generally sufficiently high to be measured by an ordinary galvanometer if one of the terminals of the instrument is connected to the insulated plate and the other to earth. The current between the plates increases as the potential difference is increased in the manner indicated in Fig. 48. The curve in some respects resembled the curve for an ionized gas (Fig. 6). The current, however, shewed no appearance of saturation. Even when the field applied rose as high as 300 volts per cm. increasing the field still produced an appreciable increase in the current. The curve in fact

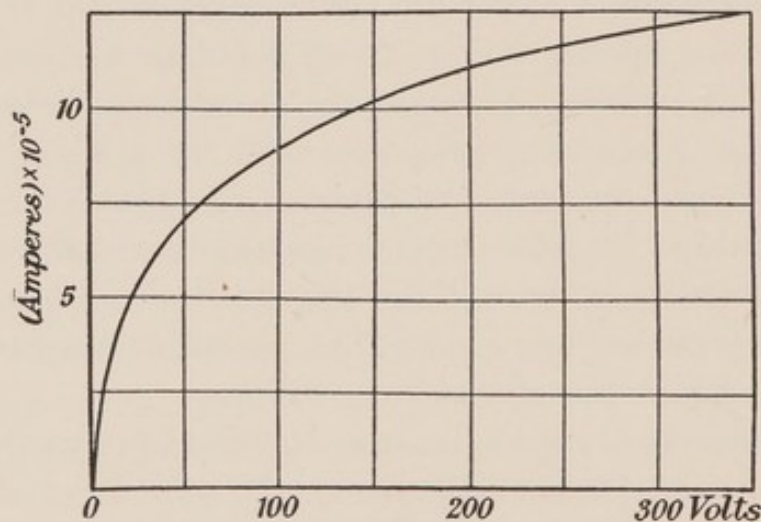

Fig. 48

approximated very closely to a parabola, and the relation between the current i and the potential difference V was expressed by an equation of the form

$$i^2 = A.V \dots \dots \dots (59)$$

where A is a constant.

The variation of the current with the distance between the electrodes also differs markedly from the saturation current through an ordinary gas. In the latter case the current for a given field is proportional to the distance between the electrodes; in the case of the current through the flame it is independent of the distance between the electrodes providing that they both remain within the flame.

67. **Distribution of potential between two electrodes in a flame.** The origin of these differences is made clear when the distribution of potential across the flame is examined. This can readily be done as in the case of the discharge tube (§ 40) by means of a fine platinum exploring wire, connected to one of the quadrants of an electrometer. The wire being in the presence of positive and negative ions takes up the potential of the point in which it is placed. Thus if two such wires are placed at a fixed distance apart and connected to adjacent quadrants of the electrometer, the deflection of the electrometer (which is proportional to the difference of potential between the two wires) will be a measure of the actual field at the part of the flame under observation.

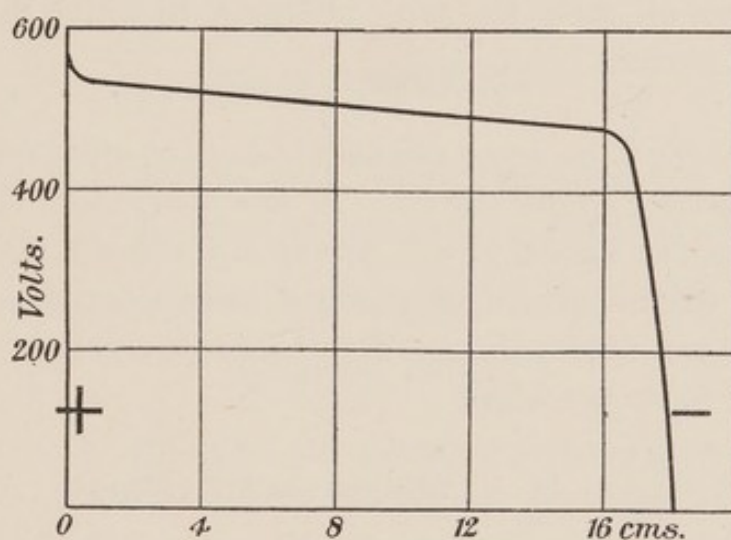

Fig. 49

Fig. 49 shews the potential at different points between two electrodes placed 18 cm. apart in a flame and maintained at a potential difference of 580 volts. The abscissae give the distance of the exploring wire from the positive electrode; the ordinates the difference of potential between the exploring wire and the negative plate. It will be noticed that the potential rises very rapidly near the negative plate, no less than four-fifths of the total change of potential taking place within the first two centimetres from the cathode. The potential then rises slowly but uniformly until the neighbourhood of the anode is reached when a further sharp rise takes place.

The field is, therefore, very intense near the cathode and very

weak but uniform across the rest of the gas, except for a slight rise near the anode. The actual field in the greater part of the flame therefore never approaches saturation value in spite of the large average value of the field between the electrodes.

The problem, which is rather interesting as throwing light on the mechanism of conduction, can be investigated theoretically as follows.

Let n_1 be the number of positive ions per c.c. at any point, e_1 their charge and k_1 their mobility; while n_2 , e_2 and k_2 denote the corresponding values for the negative ions. The current per sq. cm. at the point is thus equal to $n_1 e_1 k_1 X + n_2 e_2 k_2 X$ where X is the value of the electric field at the point. In general the ions in gases all carry the same charge e , in which case we may write, the current

$$i = Xe (n_1 k_1 + n_2 k_2). \quad (60)$$

Now if there is no accumulation of ions at any point the field will be constant across the gas. If, however, there is an excess, say, of positive ions this will produce a volume charge in the gas equal to the excess of positive over negative, that is to $e (n_1 - n_2)$ per unit volume. By the ordinary laws of electrostatics we have therefore

$$\begin{aligned} \frac{dX}{dx} &= 4\pi \times (\text{volume electrification}) \\ &= 4\pi e (n_1 - n_2). \quad (61) \end{aligned}$$

In the part of the gas where the field is constant $dX/dx = 0$, and thus $n_1 = n_2$ or the number of positive and negative ions are equal.

Now when the gas has reached a steady state the number of positive and negative ions in each unit of volume must remain constant. Hence considering unit of volume at a distance x from one of the electrodes the excess of the number of ions leaving the volume over the number entering it owing to the action of the field must be equal to the rate of formation of the ions in the unit volume less the number lost by recombination. Now the number flowing out over one face perpendicular to the current, and therefore parallel to x , less the number flowing

in at the other face is equal to $\frac{d}{dx} (n_1 k_1 X)$ for the positive ions, and $-\frac{d}{dx} (n_2 k_2 X)$ for the negative ions. Each of these quantities must by the above be equal to $q - \alpha n_1 n_2$ where q is the rate of formation of the ions and α the coefficient of recombination (§ 11). Thus we have

$$\left. \begin{aligned} \frac{d}{dx} (n_1 k_1 X) &= q - \alpha n_1 n_2 \\ -\frac{d}{dx} (n_2 k_2 X) &= q - \alpha n_1 n_2 \end{aligned} \right\} \dots \dots \dots (62)$$

Combining these equations with (61) and solving, we have, if k_1 and k_2 are constants for all parts of the field,

$$\frac{d^2 X^2}{dx^2} = 8\pi e (q - \alpha n_1 n_2) \left(\frac{1}{k_1} + \frac{1}{k_2} \right) \dots \dots (63)$$

Now in the part of the field where the potential gradient is constant the field is constant and hence dX/dx is zero, and thus $\frac{d^2 X^2}{dx^2}$ is also zero. Hence for this part of the field

$$q - \alpha n_1 n_2 = 0, \dots \dots \dots (64)$$

that is to say, the recombination exactly balances the ionization. Thus the ions formed in this layer all recombine there, none of them reaching either electrode. In other words the ionization in this part of the gas contributes nothing to the current, which is, therefore, independent both of the extent and also of the intensity of ionization in this layer. Hence so long as there is any portion of the gas in which the field is uniform the current will be independent of the distance apart of the electrodes.

On the other hand in the neighbourhood of either of the electrodes the recombination will be small. Taking the case of the cathode, for example, the negative ions are flowing rapidly away from the cathode while the positive ions are flowing in. Hence close to the electrode itself there will only be positive ions present and recombination cannot occur. Thus $\frac{d^2 X^2}{dx^2}$ will increase rapidly as the electrode is approached and hence

kind practically lets current through in one direction only, and might thus be used as a rectifier.

69. **Maximum current carried by salt vapours.** The current in salted flames is carried by the atoms of the radicles in the compound in the same way as the current in electrolytic solution. The matter has been investigated quantitatively by H. A. Wilson. A current of air was passed down a metal tube with a central wire electrode the whole being heated to a bright red heat in a furnace. If salt was added by spraying salt solution into the air current, a considerable current passed between the electrodes. This current was found to be exactly the same as that passing through a solution of the same salt in water when the rate at which the salt was being decomposed in solution was made equal to the rate at which salt was being supplied to the tube. The carriers of the current are thus the same in each case and carry the same charge.

CHAPTER IX

PHOTO-ELECTRICITY

70. **The photo-electric effect.** For some years before the development of the ionization theory gave an explanation of the effect it was known that a metal plate when illuminated by light from an arc or spark discharge emitted negative electricity. In general if the plate was carefully insulated it was found to acquire a small positive charge and hence a small positive potential, which however never exceeded about one volt. After this potential was reached the emission of electricity ceased. In most cases the effect was completely stopped if a sheet of glass was interposed between the light and the metallic plate, and it was thus shewn to be due to the ultra-violet portions of the spectrum. The alkali metals were, however, peculiarly sensitive and responded to rays from the luminous part of the spectrum even as far as the red. They could thus be excited by the light from a candle.

Whatever the nature of the surrounding medium or the state of the metallic surface the phenomenon was to be observed, but the rate at which electricity was emitted was found to be exceedingly variable, depending on the pressure and nature of the gas around the plate, the state of polish of the surface and even on the length of time since the plate was last polished. The effect is known as the *photo-electric effect*, or occasionally as the Hallwachs effect after one of its earliest investigators.

We now know that the effect is due to the emission of slowly moving negative electrons. They are often spoken of as *photo-electrons* to indicate their mode of production, but there is nothing except their speed to distinguish them from the electrons which make up the cathode rays. By enclosing the illuminated plate in a high vacuum, the ratio of the mass to the charge can be measured for the photo-electrons most conveniently by

the use of the relations (42), (43), p. 91. The ratio is found to be the same as for the cathode ray particles, that is to say, the negative emission takes the form of electrons. The effect is, in fact, a form of ionization. The light incident on the metal ionizes the atom of the metal, causing the emission of a negative electron with some small velocity; the atom itself being left with a positive charge. If the electron is ejected near the surface of the metal it will escape carrying away its negative charge. The process is thus identical with ordinary ionization except that the positive ion being in a solid is not free to move, and the whole current is carried by the negative ions.

This identity was at first concealed by the fact that ultra-violet light was not known to produce ionization in gases. Gases are, however, now known to be capable of ionization by light if light of suitable wave length is employed.

It has been found that for every substance there is a definite wave length at which the photo-electric emission commences; rays of longer wave length than the critical value producing no effect. This maximum wave length is greater according as the element is more electro-positive and shorter as the element becomes more electro-negative. Thus for the alkali metals which are extremely electro-positive, the critical or maximum wave length which will excite photo-electricity is actually in the visible spectrum being greater for caesium than for potassium and sodium; for other metals the critical wave length lies between 4000×10^{-8} and 2500×10^{-8} cm. For the non-metals waves of still shorter wave length are necessary to produce the effect: oxygen, for example, only emits photo-electrons if the incident rays have a wave length not greater than 1350×10^{-8} cm.

Now light of this wave length is exceedingly absorbable in almost all kinds of matter. It is completely absorbed by quartz, but is transmitted by an exceptionally good crystal of fluor-spar. The early attempts to ionize gases by light failed because the wave length of the radiation employed was too great.

71. Ionization of gases by ultra-violet light. Owing to their much smaller density and the difficulty of obtaining light of sufficiently short wave length, the effect in gases is

very much smaller than that at the surface of a metal, and the greatest care has to be exercised to avoid spurious effects due to the reflection of some portion of the incident light on to the metal electrodes of the chamber used for measuring the effect. The only satisfactory method is to expose the gas to the light in one chamber and then to pass it through a narrow winding tube to a second chamber in which its ionization is tested, relying on the slowness with which the ions recombine to enable them to persist until they can be measured. A suitable form of apparatus used by Hughes is shewn in Fig. 50. The light is produced by a discharge in hydrogen in a discharge tube *T* of special shape, the hydrogen discharge being very rich in the extreme ultra-violet. The gas under investigation

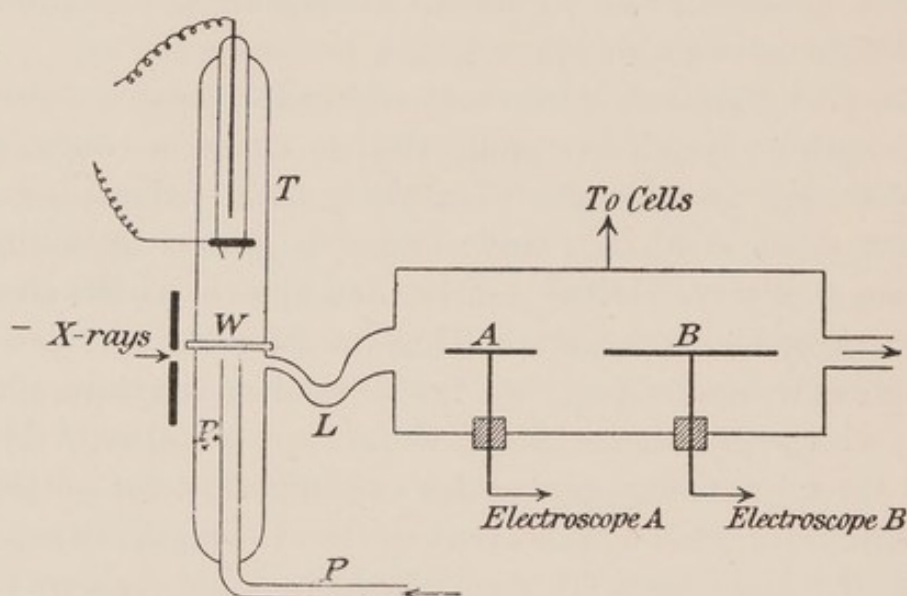

Fig. 50

is passed through the tube *P* and emerges close to a window *W* of exceptionally transparent fluor-spar, where it is ionized by the rays transmitted. It then flows through the winding tube *L* to the ionization chamber. If any ions are formed in the gas a current passes between the outer wall which is connected to a battery of cells and the electrode *A*. The second electrode *B* enables an estimate to be made of the coefficient of recombination of the ions formed. Keeping the apparatus the same but replacing the light by X-rays it can be shewn by direct comparison that the ions have the same coefficient of recombination in the two cases, and are thus presumably of the same nature.

The hydrogen discharge gives radiation of wave lengths from 1300 to 1600. Thin quartz becomes transparent for rays of wave length about 1450. If the fluor window W is replaced by quartz no ionization is produced in air. Hence the maximum wave length for air is somewhere between 1300 and 1450, or roughly 1350 as stated above. In chlorine which is still more electro-negative all attempts to produce ionization by light have so far failed. Various compound gases such as carbon dioxide and ammonia are ionized by the light coming through a thin quartz window, that is their maximum wave length is greater than 1450×10^{-8} cm.

72. Velocity of emission of the photo-electrons. It is found that a plate illuminated by ultra-violet light gives electrons of all velocities from a certain maximum downwards. The velocity is most conveniently measured by measuring the difference of potential necessary to prevent the escape of electrons from the plate. Suppose the metal plate emitting the electrons is at a positive potential V . The negative electron will experience a force attracting it backwards to the plate and by the time it reaches a place of zero potential it will have lost a quantity of energy equal to Ve , where e is its charge. If the original energy with which it left the plate was E it will now have energy equal to $E - Ve$. If this is equal to zero it will just escape being dragged back to the plate. Obviously if it is less than zero its motion will be reversed and it will return to the plate again. Thus the minimum velocity an electron can have to escape is given by

$$\frac{1}{2}mv^2 = Ve,$$

$$v^2 = 2V \frac{e}{m}.$$

If the active plate is surrounded by conductors at zero potential and carefully insulated it will gradually acquire a positive potential owing to loss of negative electricity. This potential will grow until it is just sufficient to prevent the escape of the fastest electrons which the plate emits. Thus a measurement of the potential acquired by a plate exposed under these circum-

stances to ultra-violet light will enable us to estimate the velocity of the swiftest electrons emitted.

On this account the very objectionable practice has grown up of stating the velocity in terms of the voltage acquired by the plate, and thus phrases like "a velocity of one volt" have become common. As will be seen from the formula the velocity is not even proportional to the potential but to the square root of it. The real velocity can readily be calculated from the formula, since e/m is equal to 1.77×10^7 e.m.u. Thus a "velocity of one volt" or 10^{-8} e.m.u. is equal to about 5.9×10^7 cm./sec.

Experiments have shewn that the velocity with which electrons are emitted is independent of the intensity of the light, and depends only on the frequency. It is found that for a given metal the potential acquired under the action of light of frequency n can be expressed by the relation

$$V = kn - V_0, \quad (66)$$

where k and V_0 are constants. The meaning of the equation can be made clearer by multiplying throughout by e , the charge on an electron and transposing,

$$Ve + V_0e = kne. \quad (67)$$

Ve is then the energy with which the electron actually escapes from the surface, and V_0e may be regarded as the energy lost by the electron in escaping from the interior of the atom. The left-hand side of the equation thus represents the initial energy given to the electron by the light, and in this form the equation shews that the total energy given to an electron by a light wave is proportional to the frequency of the light. The value of V_0 varies with the nature of the substance from 2.57 volts in the case of calcium to about 8 volts in the case of oxygen. The value of k is independent of the nature of the substance.

73. The "quantum" theory of radiation. This important result brings us to a consideration of a very fundamental and important theory of radiation which although originally propounded to explain quite a different set of phenomena has most important bearings on the photo-electric effect. It

has been suggested by Planck and Einstein that the interchange of energy between radiant energy and matter takes place, not continuously, but in certain definite small units, or bundles as it were, of energy which are known as *quanta*. Thus when a body gives out radiation of any sort it does so not continuously but in separate discrete amounts each of which forms a distinct bundle or *quantum of energy*. Conversely if radiant energy is taken up by any system that system must absorb either the whole or none at all of the individual quantum which falls upon it, though it may of course absorb two or more complete quanta under suitable circumstances. These quanta may be regarded as atoms of energy.

It can be shewn that the size of the quantum varies continuously with the frequency of the radiation. If n is the frequency then the energy δ making up the quantum for that frequency is given by

$$\delta = hn \dots \dots \dots (68)$$

where h is a universal constant known as Planck's constant. Its value can be deduced from the laws of radiation and is found to be 6.55×10^{-27} ergs.

The significance of this law is obscure, the original assumptions of Planck being open to grave objection. There is no doubt that it represents a fundamental law of radiant energy. It has been applied with great success not only to the complete radiation from a black body, from which it was originally deduced, but also to the absorption of light, to electrical conductivity and to the specific heat of the elements, where for example it gives an explanation of Dulong and Petit's law of atomic heats. It throws great light on the question of photo-electric emission.

It follows from this law that when light of frequency n falls upon a metal the electrons in it must absorb the corresponding quantum of energy, or remain entirely unaffected. The energy in the affected electron will thus be equal to the energy in the quantum falling upon it, that is hn , since the energy in each quantum is independent of the intensity of the radiation which only governs the number of quanta falling per second on the surface. Hence the velocity of ejection of the electrons will

be independent of the intensity of the light, a result already obtained experimentally. Again since the energy of the electron is equal to hn we have an immediate explanation of equation (67), ke being obviously the constant h . Since $h = 6.55 \times 10^{-27}$ and $e = 4.7 \times 10^{-10}$ e.s.u. we have $k = \frac{6.55 \times 10^{-27}}{4.7 \times 10^{-10}}$ e.s.u. or 4.19×10^{-15} volts, a result which agrees fairly closely with the values obtained for this constant by direct experiment.

The application to gases is equally satisfactory. The minimum frequency which will excite the ionization in oxygen is as we have seen 1350×10^{-8} cm. which corresponds to a frequency of $\frac{3 \times 10^{10}}{1350 \times 10^{-8}}$ vibrations per sec. The energy in the quantum is thus $(6.55 \times 10^{-27}) \times (2.2 \times 10^{15})$ or 1.45×10^{-13} ergs. This corresponds very closely with the value 1.4×10^{-13} ergs for the energy required to ionize a molecule of oxygen obtained by the direct method described in § 31.

It is an almost inevitable consequence of the quantum theory, that these quanta should be regarded as bundles of energy proceeding in definite straight lines along a definite path (for example, along a single Faraday tube), and not as spreading out in circular waves. The fact that the whole of the quantum can be absorbed by a single electron (which certainly has a volume of not more than 10^{-38} c.c.) at any distance from the point where the quantum was radiated, makes any other hypothesis almost unthinkable. The difficulties to which this conception of the nature of radiation gives rise are great, and no hypothesis has yet been evolved which will give even a partial explanation of them. For the explanation of the phenomena of the present and the following chapter some such theory, however, seems almost inevitable.

74. Distribution of velocities among the photo-electrons. So far we have considered only the maximum velocity of the electrons which emerge from the metal. If we maintain a constant difference of potential V between the radiator and its surroundings less than the maximum positive potential which would be acquired by the plate, the rate of loss of

electricity from the plate, that is, the negative current from it, will be proportional to the number of electrons which leave the plate with an energy greater than V_e the energy which would be required to escape from the positively charged plate. In this way the proportion of the electrons which emerge with various velocities less than the maximum can be measured.

On making the experiments it is found that the electrons emerge with all velocities from zero up to the maximum. It need not be assumed (and is indeed very improbable) that they are actually ejected from the atom with different velocities. The electrons will be formed at different depths in the metal (since the light can penetrate small thicknesses of metal) and hence will have different thicknesses of metal to traverse before escaping from the surface. Now in passing through matter electrons lose velocity owing to collisions with the molecules. Thus these electrons which are formed at the surface, having no matter to traverse will escape with the actual velocity with which they left the atom. Those formed deeper in the metal will lose some of their velocity before reaching the surface, until at last a layer is reached the electrons from which will be unable to penetrate to the surface at all.

75. Magnitude of the photo-electric effect. *The magnitude of the photo-electric effect may be defined as the total current from unit area of the illuminated surface when its potential is favourable to the escape of negative electricity.* Except under very special conditions it is an exceedingly variable quantity, and many futile experiments have been made on it. In the presence of gas it is found to depend on the pressure of the gas in a very complicated way. All surfaces condense on themselves a surface layer of gas or vapour which is exceedingly difficult to remove even in a vacuum. This layer may also be electrically charged and so influence the escape of the photo-electrons not only by its absorption but also by its field. Consistent results can only be obtained with films or surfaces not only kept but also prepared in the highest vacua obtainable and never exposed at any period to the action of a gas at a perceptible pressure. This applies also but to a smaller extent to experiments on the

velocity of the electrons, especially if the layer is charged. Velocities as much as six or seven times the normal maximum for the metal have been observed for example in the case of a radiator which has been used as the cathode in a discharge tube.

An apparatus suitable for the preparation and investigation of a metallic surface in vacuo is shewn in Fig. 51. The

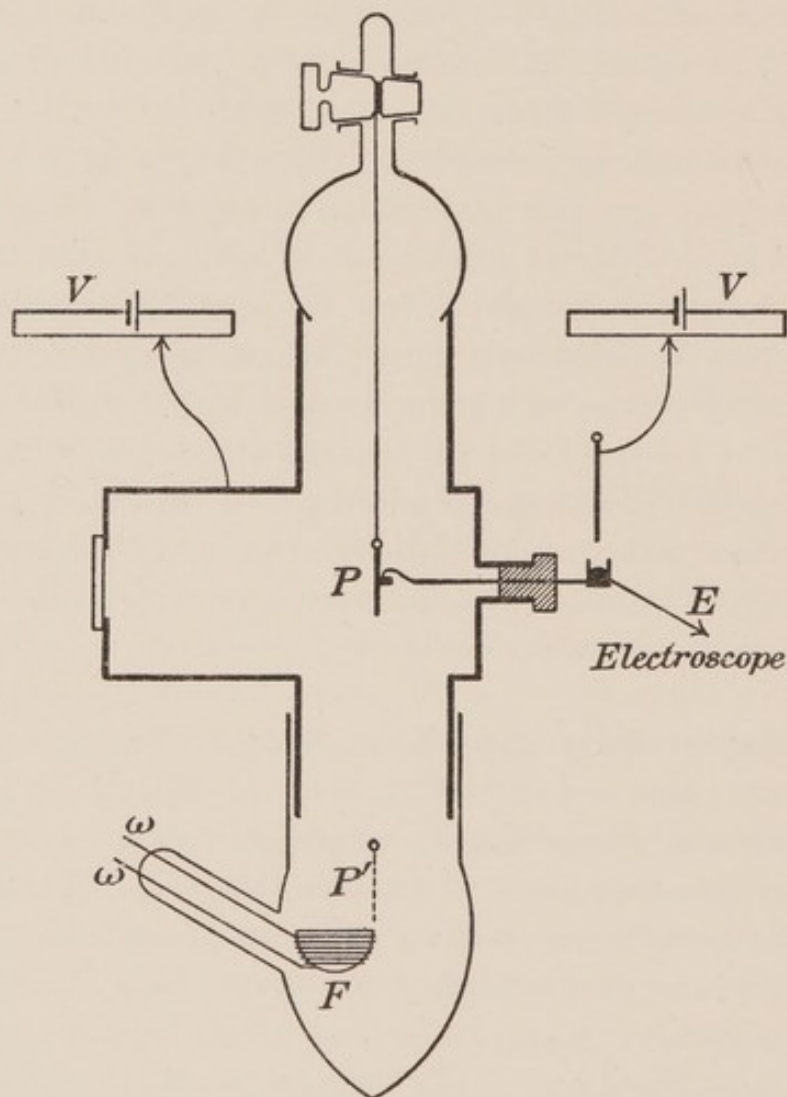

Fig. 51

thick lines represent the metallic part of the apparatus which extends far enough on all sides to screen the plate P from external electrostatic effects. When in the position shewn the plate makes metallic contact with a Wilson electroscop E , while the two potentiometers V, V can be adjusted so as to maintain a constant measured difference of potential between the radiator and its surroundings. To obtain a film on the

radiator P it is lowered to the position P' opposite the mouth of a small quartz crucible F , which contains the metal under investigation and can be electrically heated by the wires ω , ω passing through the walls of the tube. The metallic vapours condense on the cold plate forming a film which, as the whole apparatus is maintained at a high vacuum, has never been in contact with gas and so is free from the disturbing surface layer. If the outer case is earthed the maximum potential acquired by the plate P as measured by the electroscope gives the maximum velocity of emission of the photo-electrons, as already explained. By applying a small accelerating potential sufficient to produce the maximum emission the total photo-electric effect can be measured.

With films prepared and kept in vacuo, the total photo-electric effect is found to be directly proportional to the intensity of the light for intensities varying in a ratio of as much as 1 to 10^6 . On account of its importance with respect to the quantum theory of radiation experiments with exceedingly small intensities of illumination have been made, but even when the energy was as small as 10^{-7} ergs per sq. cm. per sec. no departure could be observed from the proportionality between the intensity and the current. The current is also independent of whether the light is continuous or is given out in a series of brief flashes. As long as the average energy remains constant the emission remains the same.

Temperature also is without influence on photo-electric emission on surfaces in vacuo although it has a considerable effect on surfaces in air, probably owing to changes in the layer of condensed gas.

76. Variation of the photo-electric effect with wave length and state of polarization. For the majority of metals the photo-electric effect increases as the wave length of the exciting radiation diminishes. The alkali metals for a certain part of the spectrum and with oblique incidence of the light form an exception; the current rising to a fairly sharp maximum at a definite wave length. In these metals the effect also depends on the plane of polarization of the incident light.

Let light be incident obliquely on a surface, say, of liquid alloy of sodium and potassium. These liquid alloys are convenient since they give perfectly plane surfaces. The plane containing the ray and the normal to the surface is known as the plane of incidence. According to the electro-magnetic theory of light, if the light is plane polarized in the plane of incidence the electric field in the pulse will be perpendicular to this plane, that is, parallel to the surface of the radiator. We will denote this state as the E_{\parallel} plane to indicate that the electric force is parallel to the radiating surface. On the other hand, if the light is plane polarized at right angles to the plane of incidence

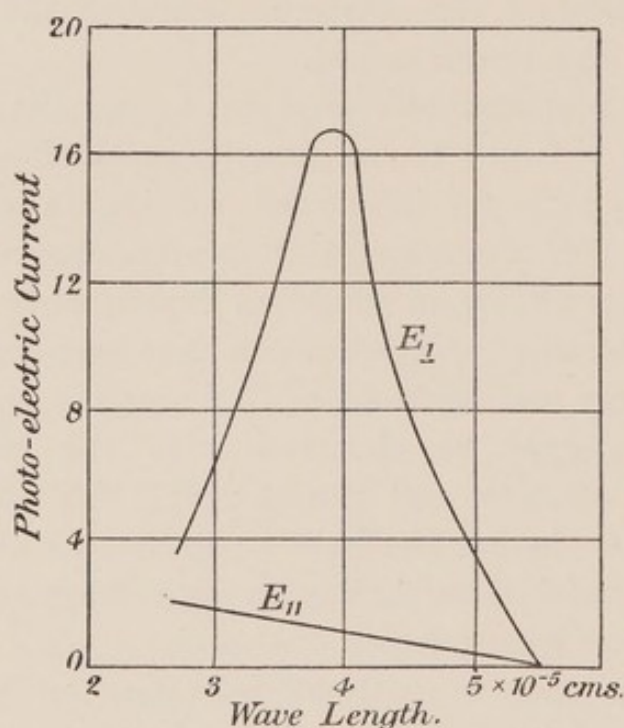

Fig. 52

the electric field will be parallel to the plane of incidence and thus will have a component if the ray is oblique, perpendicular to the surface. The more oblique the incidence the greater this component. We will denote this state of polarization by E_{\perp} .

If now experimental curves are drawn between the photo-electric intensity and the wave length of the incident light for the two states of plane polarization the results shown in Fig. 52 are obtained. It will be seen that when the electric field in the light waves is parallel to the surface of the radiator the emission decreases uniformly as the wave length is increased.

When, however, the light is polarized so that the electric field in the radiation has a component perpendicular to the radiator, the emission rises rapidly as the wave length decreases, reaches a maximum for a certain definite wave length and then decreases until it joins the other curve. The maximum intensity increases with the obliquity of the rays, but the corresponding wave length is constant. The ratio of the maximum to the normal effect differs widely for different surfaces even of the same alloy. It is normally as much as 15 to 1, but has been observed as high as 300 to 1, with an angle of incidence of 60° . The velocity of the electrons emitted is the same in the two cases.

So far as is yet known this selective effect is confined to the alkali and alkali earth metals and is only apparent over a comparatively short part of the spectrum. In the diagram (Fig. 52) which represents the case of a sodium-potassium alloy the maximum effect is reached at a wave length of 3400×10^{-8} cm.; for potassium the corresponding wave length is 4490 and for rubidium about 5000, that is, in the yellow green of the visible spectrum. The curve obtained with unpolarized light may obviously be obtained by compounding the two separate curves. If the light is incident normally on the surface the effect, of course, disappears, since the light has then no component normal to the surface.

The photo-electric effect is of considerable magnitude, especially in the case of the alkali metals which as we have seen have their maximum efficiency in the visible spectrum. The current produced can be largely increased by making use of ionization by collision, in the surrounding gas. Rubidium cells containing some inert gas such as argon at a pressure, chosen so as to produce the maximum amount of ionization by collision, have been used as radiometers to measure small quantities of radiation. Such a cell will easily detect the light radiation from a single candle at a distance of three miles, and is thus not at all inferior in its powers to the human eye.

77. Photo-electric fatigue. If a plate is polished and tested at various intervals, it is found that its photo-electric efficiency decreases. Thus the current from a polished copper

plate falls to one-third of its initial value if exposed to the air of a room for a single day. If on the other hand it is kept in a closed vessel containing air at the atmospheric pressure, the same amount of fatigue takes three months to develop. The effect doubtless has to do with the surface layer of gas condensed on the metal. Careful experiment has shewn that it does not occur with perfectly gas free surfaces kept in high vacua. The effect has been ascribed to ozone, to hydrogen peroxide, and to other gases, but the observations of different experimenters are exceedingly discordant.

78. Photo-electric effect in non-metals. The photo-electric effect can also be detected in non-metals, but owing to their more electro-negative character the maximum wave length at which the effect commences is smaller than in the case of metals. For carbon, for example, the emission of electrons begins when the wave length is reduced to 2550. The observations are somewhat more difficult to make if as usually happens the non-metal is also a non-conductor. In this case the charge on the surface is not conducted to a wire leading to the electrometer, and the positive charge accumulates until its potential is sufficient to stop the emissions of the photo-electrons. The accumulated charge can be measured by transferring the substance bodily into a Faraday cylinder connected with an electrometer. The charge measured by the electrometer is by the ordinary laws of electrostatics equal to that on the substance. The emission of electrons takes place throughout the mass of the substance as far as the light penetrates it. Owing to the presence of these free electrons in the substance a certain conductivity is imparted to those layers of it which actually come under the action of the light which lasts so long as the illumination is continued. Thus if a sheet of sulphur is enclosed between two electrodes and illuminated by the light from a quartz mercury lamp a current passes which increases uniformly with the voltage between the two electrodes. The conductivity is independent of the applied field up to 400 volts per mm. With a field of this intensity currents of the order of 2×10^{-9} amps. were observed when the sulphur was illuminated.

79. **Phosphorescence and the photo-electric effect.** No connection can be traced between photo-electricity and fluorescence, many fluorescent compounds being quite inactive. On the other hand, phosphorescent substances always shew a well-marked photo-electric effect. Thus calcium sulphide with a trace of powdered bismuth and a flux of sodium borate yields a very actively phosphorescent substance. On testing this it was found to be exceedingly photo-electric also, giving a photo-electric effect nearly as large as brightly polished magnesium. The three substances taken separately and also in pairs were found to be neither phosphorescent nor markedly photo-electric. By using absorbing screens it could also be shewn that light which did not produce phosphorescence did not produce a photo-electric effect. The two effects, therefore, seemed to run parallel to each other.

It has been shewn that phosphorescence is due to certain active centres in the "phosphor." In all probability these centres under the action of light emit an electron which if the centre is sufficiently near the surface escapes as a photo-electron. If the centre is too deep for this the electron remains embedded in the substance, which is always a non-conductor. Eventually, however, under the action of the attraction of the now positively charged centre the electron finds its way back into the "centre," producing disturbances there which cause the emission of the phosphorescent light. The photo-electric effect is thus connected with the excitation of phosphorescence, and not with the phosphorescence itself. The photo-electric effect itself ceases as soon as the exciting radiation is cut off.

CHAPTER X

X-RAYS

80. **Production of X-rays.** It was discovered by Röntgen in 1895 that if a discharge tube at low pressure was worked in the neighbourhood of a fluorescent screen the latter became illuminated as if exposed to ordinary light, and photographic plates were also affected, even though protected in their usual wrapping of opaque black paper. These effects were found to have their origin in radiations proceeding from those portions of the walls of the discharge tube struck by the cathode rays. These radiations pending a further inquiry into their nature were called X-rays. They have also been called Röntgen rays, after

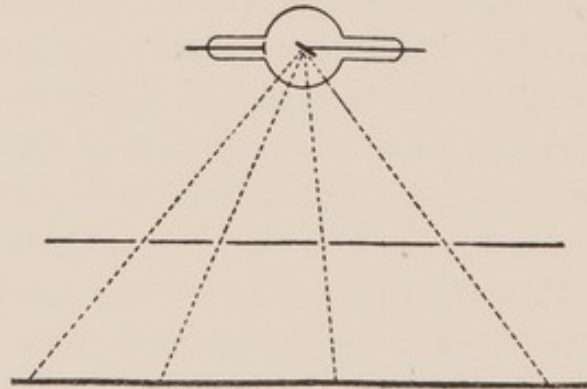

Fig. 53

their discoverer. The former term, however, seems to have found more favour, and is now almost universally employed.

The fact that the photographic plates are affected through the black paper shews that the rays can traverse substances opaque to ordinary light. Their penetrating power indeed depends principally upon density, light substances like paper, flesh, wood, etc., being relatively transparent to the rays, while dense ones such as bone, and most of the metals, being comparatively opaque. Thus, if a hand is placed between the source of the X-rays and a fluorescent screen the shadows

cast by the relatively opaque bones are distinctly visible, a result which has given these rays their great importance in surgery.

The shadows cast by the rays coming from the walls of an ordinary discharge tube are naturally blurred owing to the finite area of cross section of the cathode beam. If, however, we focus the cathode rays on to a single point by making use of a concave cathode a point source of X-rays is obtained and sharp shadows are cast. By joining points on the shadow to corresponding points on the obstacle (Fig. 53) and producing the lines backward they are found to meet in the spot where the cathode rays meet the walls of the tube, thus shewing that the X-rays start from the point struck by the cathode rays and travel out from it in all directions in straight lines.

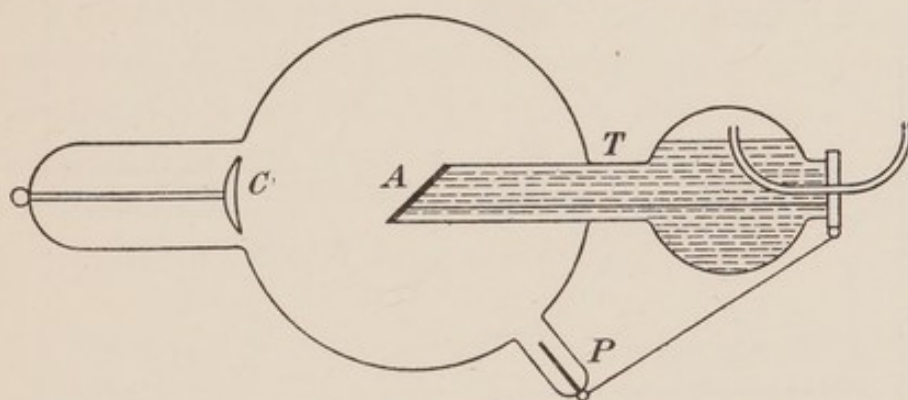

Fig. 54

Owing to the large amount of energy conveyed by the cathode rays it is impossible to focus them on the walls of the tube, the heat generated at the focus being sufficient to fuse glass in a few seconds. To overcome this difficulty the cathode rays are focused on a platinum or better still a tungsten plate supported in the centre of the discharge tube, and known as the anti-cathode. Even so with the currents which it is now possible to pass through the discharge tube the anti-cathode rapidly becomes red hot, unless special devices are employed to cool it. Of these the most successful is that in which the anti-cathode is cooled by water. A modern X-ray tube of this kind is figured in Fig. 54.

The cathode *C* is concave, and of aluminium, and is placed just in the neck of the bulb. The anti-cathode is a plate of

platinum which is fused on the end of the tube T which can be filled with water. A separate anode P is also placed in the tube, and is in metallic connection with the anti-cathode. The action of the separate anode is somewhat obscure, but it has been found in practice to improve the working of the tube. The tube is generally run by some form of induction coil. In modern X-ray photography the vacuum of the bulb is adjusted so that it works with a difference of potential of about 150,000 volts and currents of from 3-5 milliamperes are usually employed in the tube. The production of heat in the bulb is therefore some 150 calories per second.

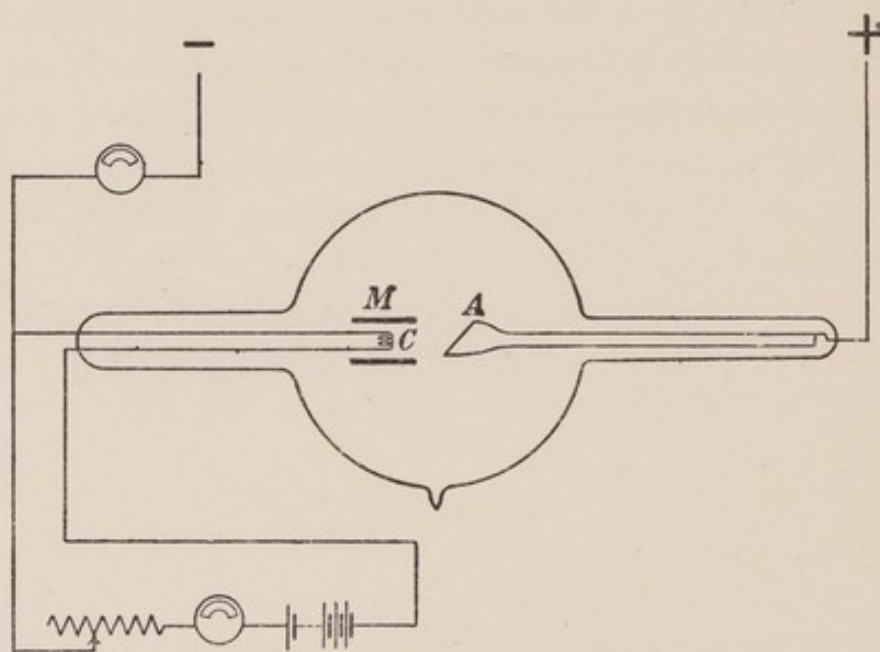

Fig. 55

We have seen that the potential required to send a discharge through a vacuum tube depends on the pressure of the residual gas; the smaller the pressure the higher is the required potential difference, and in consequence the greater the speed of the cathode rays. The quality of the X-rays produced depends on the velocity of the cathode rays. Thus a slight change in the pressure of the residual gas, which easily occurs when the tube is running, makes a considerable difference to the penetrating power of the rays. Also with the ordinary type of X-ray tube the penetrating power can only be altered by adjusting the vacuum. Devices for this are generally attached to the tube, but the adjustment requires some degree of experimental skill.

To avoid these difficulties a new type of tube, invented by Coolidge, has been placed on the market (Fig. 55). This tube is exhausted so completely of gas that no discharge can be sent across it when cold owing to the insufficient number of possible carriers left in the tube. To provide carriers for the discharge the cathode *C* is made of a spiral of tungsten wire which is heated to incandescence by means of an electric current. Large quantities of thermions are emitted, the number being a function of the temperature of the wire (§ 61). These thermions have very small velocities, but can be speeded up to any required extent by applying the corresponding P.D. across the tube. The velocity of the electrons and hence the quality of the X-rays emitted depends only on the P.D. applied across the tube; the current through the tube depends only on the number of electrons emitted per second from the glowing spiral, that is, on its temperature. The tube is therefore completely under control.

The negative electrons can be focused into a beam by surrounding the wire with a tube of molybdenum, *M*. The anti-cathode *A* is made of a massive block of tungsten. No cooling device is necessary.

81. Radiations emitted by the stoppage of a moving electrified particle. The fact that the X-rays have their origin at the point struck by the cathode rays led Sir G. Stokes to suggest that they are electro-magnetic waves set up by the sudden stoppage of the rapidly moving electrons which make up the cathode stream. This view is now generally accepted.

The effect is most readily understood by a consideration of the Faraday tubes of force. If a charged cathode particle is moving with a speed which is small compared with that of light, its electric field will be the same as that for a particle at rest, and the tubes will be therefore distributed uniformly round the particle. Assigning all the effects in the field round the charge to the action of the Faraday tubes it can be shewn that the motion of a single Faraday tube of force produces a magnetic field in the medium which is perpendicular to the length of the tube and to its direction of motion, and equal to $4\pi v$, where v is the velocity of motion of the tube in a direction perpendicular to

its length. (See J. J. Thomson, *Elements of Electricity and Magnetism*, Chap. XIII.)

Consider a single charged particle moving along a direction OX with a velocity v . This particle will carry with it a number of Faraday tubes of electric force, which when the motion has become steady will travel along as if rigidly attached to the particle.

Suppose the particle is suddenly stopped by striking a solid obstacle at the point A (Fig. 56), and let us suppose that disturbances are propagated along the Faraday tubes with a finite velocity c . It can be shewn that this velocity is the velocity of light.

Let t be the time that has elapsed since the particle was stopped. Describe round A a sphere of radius ct . Then all the

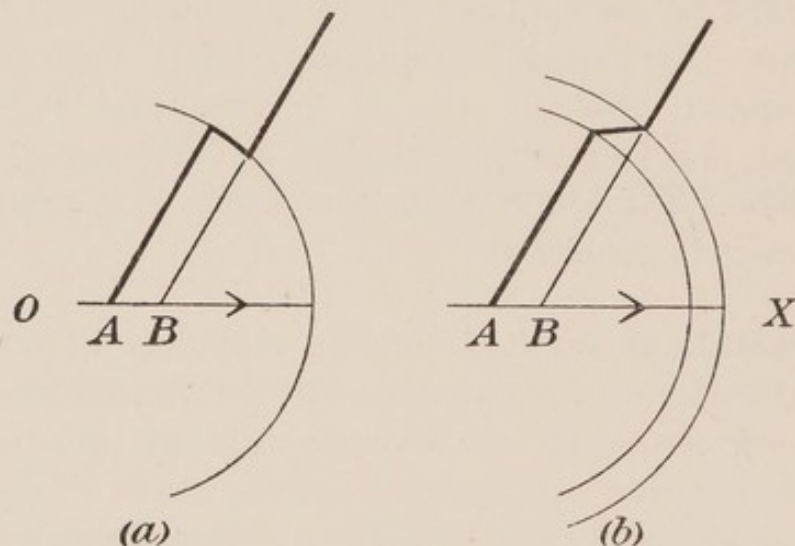

Fig. 56

portions of the tubes inside this sphere will be radiating from the stationary position of the particle at A . Outside this sphere however the disturbance produced in the Faraday tubes by the stoppage of the particle will not have arrived. They will thus be still moving in the direction OX with their original velocity v , and will be radiating from the position which the particle would have reached if it had not met the obstacle, that is, from a position B along OA produced where AB is equal to vt .

There will thus be a relative displacement between the two portions of the tube of force, and as we must regard the tube as

continuous it is evident they must wrap themselves round the surface of the sphere.

This sphere is expanding with a velocity c , and we thus have a sheet of electric force travelling out with a velocity c from the position of the particle. But the motion of the Faraday tubes at right angles to their length produces a magnetic field perpendicular to the Faraday tubes and to the direction in which they are moving, that is to say, also in the surface of the sphere. Thus a sheet of electromagnetic disturbance spreads out from the particle. This, on Stokes' theory, constitutes an X-ray.

It will not in general be possible to stop the particle abruptly. If τ is the time taken to reduce the particle to rest, the disturbance will be enclosed by two spheres of radii ct and $c(t + \tau)$ (Fig. 56 *b*). The thickness of the disturbance or pulse will thus be $c\tau$ and will be smaller the more quickly the particle is stopped.

Let Fig. 56 *b* represent this state of affairs. Then, since $AB = vt$,

$$\frac{\text{tangential electric polarization}}{\text{normal electric polarization}} = \frac{vt \sin \theta}{\delta}$$

where δ is the thickness of the pulse and θ is the angle between the direction of the tube and AX . But the normal polarization is $e/4\pi r^2$ and thus since $r = ct$ the tangential electric polarisation

$$= \frac{e}{4\pi r\delta} \frac{v \sin \theta}{c} \dots \dots \dots (69)$$

Now since this is moving at right angles to its direction with a velocity c it will produce a magnetic force H , equal to $4\pi c$ times the polarization, that is

$$\frac{ev \sin \theta}{r\delta} \dots \dots \dots (70)$$

Since these fall off inversely as the distance from the particle while the normal polarization falls off as the inverse square of the distance, the intensity in the pulse except for points near the particle will be great, compared with the intensity outside it. We shall thus get a pulse of electromagnetic disturbance travelling out from the particle, and behaving in many

respects like ordinary light. The chief differences are that in the first place the thickness of the pulse is found to be small compared with the wave length of visible light, while in the second place the X-rays lack that regular periodic character which occurs in a train of waves of constant wave length.

The energy in a pulse of this kind being equally divided between the electric and magnetic fields is equal to $2 \times \frac{\mu H^2}{8\pi}$ per unit volume, i.e.

$$\frac{\mu e^2 v^2 \sin^2 \theta}{4\pi r^2 \delta^2}$$

The energy radiated is thus zero along the direction of motion of the particle, and rises to a maximum at right angles to this direction. The volume of shell included between radii, making angles θ and $\theta + d\theta$ with the axis AB is therefore $\delta r \sin \theta 2\pi r d\theta$, and the total energy in the shell

$$2 \int_0^{\frac{\pi}{2}} 2\pi r^2 \sin^2 \theta \delta \frac{\mu e^2 v^2 \sin^2 \theta}{4\pi r^2 \delta^2} d\theta = \frac{2}{3} \frac{\mu e^2 v^2}{\delta} \dots \dots \dots (71)$$

on substituting for H from (70) and evaluating the integral. The energy is thus inversely proportional to the thickness of the pulse. Thus the more suddenly the particle is stopped the greater the energy radiated.

The method can easily be extended to the case of the acceleration of a charged particle which is not actually brought to rest. If f is the acceleration then the time τ which would be taken for the particle to be brought to rest is given by

$$v = f\tau.$$

Substituting this value for τ , and the value $c\tau$ for δ in equations (69) and (70) we have

$$\text{Tangential polarization } D = \frac{ef \sin \theta}{4\pi r c^2} \dots \dots (72)$$

$$\therefore \text{Magnetic induction } H = \frac{ef \sin \theta}{rc} \dots \dots (73)$$

The flow of energy across unit area therefore (by Poynting's Theorem) is $c^2DH = \frac{e^2f^2 \sin^2 \theta}{4\pi r^2 c}$ (74)

Integrating over the area of the sphere of radius r we have

$$\text{rate of loss of energy} = \frac{2}{3} \frac{e^2 f^2}{c} \text{ (75)}$$

82. The scattering of X-rays by matter. Suppose the radiation from one electron falls upon another. The second electron while the pulse is passing over it will be subject to an electric field X and will thus have an acceleration

$$f_1 = X \frac{e}{m} = \frac{4\pi e D}{m} = \frac{e^2 f \sin \theta}{mrc^2}$$

substituting for D from (72). This electron will, therefore, give out radiation which, since f_1 is proportional to f , will have the same quality as the radiation exciting it.

Thus if a beam of primary X-rays falls on a material substance, since all matter contains electrons, secondary X-rays will be given out in all directions which, since they are found to be of the same quality as the rays exciting them, have been called "*scattered radiation*," in order to distinguish them from another type of secondary radiation which may also be emitted the quality of which depends not on the primary radiation but on the chemical nature of the radiator. This latter type is often called "*characteristic*" radiation, since it is characteristic of the radiator used for the experiment.

These effects can easily be observed by allowing a narrow pencil of X-rays to fall on a thin sheet of aluminium, or paper. An electroscope placed near the radiator, but out of the direct line of the primary pencil, will lose its charge, shewing that ionizing radiations are being given out by the radiator. If the radiator is removed the rate of loss of charge becomes very small. If, however, a sensitive electroscope is employed it is possible to observe a residual effect due to the action of the primary pencil on the molecules of the air.

The scattered radiation is not uniformly distributed about the radiator. The simple theory already outlined leads to the conclusion that I_θ the intensity of the radiation emerging from

the radiator at an angle θ with the primary rays should be expressed in the form

$$I_{\theta} = I_{\frac{\pi}{2}}(1 + \cos^2 \theta) \quad . \quad . \quad . \quad . \quad (76)$$

where $I_{\frac{\pi}{2}}$ is the scattered radiation emerging at right angles to the primary beam. The scattered radiation is thus a minimum in this direction, and approaches twice this value as the direction of the primary beam is approached.

Careful experiments have shewn that this relation is not strictly true. In every case the intensity of the radiation on

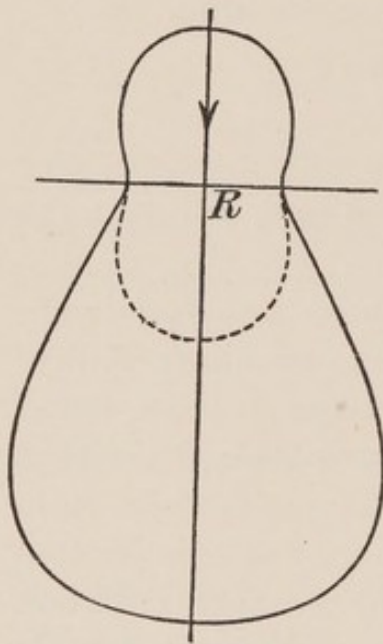

Fig. 57

the side of the radiator from which the primary rays emerge is greater than that given out at a similar angle from the face by which the rays enter. The distribution is thus unsymmetrical about a plane through the radiator at right angles to the primary beam. This is shewn by the thick line curve in Fig. 57, which represents the author's results for the actual distribution of the scattered radiation around a thin aluminium radiator placed at R . The dotted line gives the theoretical distribution as determined by (76).

The divergence is probably due to the

disturbance produced by the neighbouring electrons in the atom on the path of the vibrating electron.

83. Polarization of the scattered radiation. Consider a beam of cathode rays falling on an anti-cathode at O in the direction DO (Fig. 58). If the first impact of the electrons produced an X-ray the acceleration of the electrons would be in the direction OD , and the electric force in the resultant pulse at any point along the ray OP would be parallel to the plane of the paper. As a matter of fact the distribution of the primary rays round the anti-cathode shows that many of the cathode particles must experience considerable deviations owing to collisions with the electrons in the anti-cathode before producing a Röntgen ray, but at any rate we may expect a

preponderance of direct collisions and therefore a maximum electric force parallel to the plane of the paper. The effects will, therefore, be similar in kind but somewhat less in amount than in the simple case where all the electrons are stopped at the first collision. Since there is an excess of electric field in the pulses in a definite direction the emerging beam may be said to be polarized.

Suppose now that this partially polarized radiation falls on a mass of gas at P . The electric force will cause the electrons in the gas molecules to have an acceleration (§ 82), which if the beam is completely polarized will be in the direction PQ since the field must be in the plane of the paper and also perpendicular to the direction of the ray. Thus the electrons will be set vibrating in the direction PQ , and will emit radiation

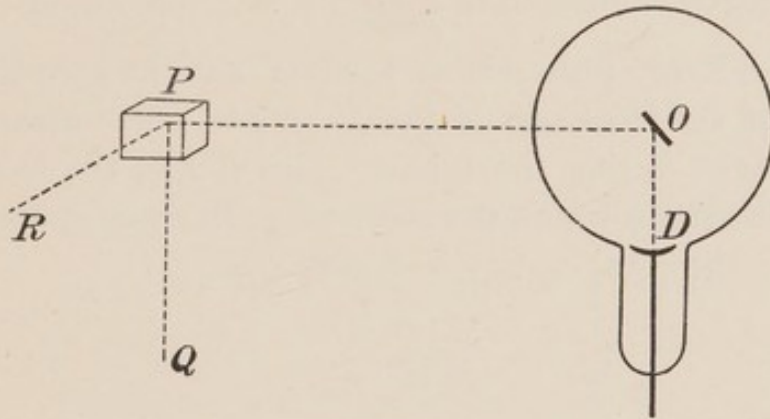

Fig. 58

which as we have seen will be zero in the direction of motion of the electron, and a maximum at right angles to it. Thus if the primary rays were completely polarized there would be no scattered radiation in the direction PQ while it would reach a maximum in a direction PR through P perpendicular to the plane containing OD and OP . In other words if we allow the rays from an X-ray tube to fall on a radiator we should expect that the scattered radiation would be a minimum in a line through the radiator parallel to the incident cathode rays, and a maximum in a direction at right angles to this. The experiments were carried out by Barkla in 1904 and shewed a very marked effect, the polarization often reaching as much as 20 per cent. The actual amount depends on the hardness of the rays and the nature of the anti-cathode.

84. Energy of the scattered radiation. The following expression has been deduced by Prof. Sir J. J. Thomson for the energy of the scattered radiation. From (75) we have rate of loss of energy $= \frac{2}{3} \frac{e^2 f^2}{c}$ where f is the acceleration produced in the radiating electron. The total energy given out when one complete pulse passes over the electron

$$= \frac{2}{3} \frac{e^2}{c} \int f^2 dt, \quad \dots \dots \dots (77)$$

the integration extending throughout the time for which the pulse is acting on the electron. But $f = \frac{Xe}{m}$ where X is the electric field in the primary pulse at any moment, and the energy radiated is therefore $\frac{2}{3} \frac{e^4}{m^2 c} \int X^2 dt$. We do not know the form of the X-ray pulse. If we assume that the field is constant throughout the thickness of the pulse and zero outside it, X is then constant during the time t . Also if δ is the thickness of the pulse the time which the pulse takes in crossing the electron is δ/c , and the total energy becomes

$$\frac{2}{3} \frac{e^4}{m^2} \frac{X^2 \delta}{c^2}.$$

But the energy in the primary pulse per unit area is given by

$$E = \frac{1}{4\pi} \frac{X^2 \delta}{c^2}.$$

Hence

$$E' = \frac{8\pi}{3} \frac{e^4}{m^2} E. \quad \dots \dots \dots (78)$$

This is the energy radiated by a single electron. If there are N electrons per unit mass and we assume that they do not influence each other's motion the total scattered radiation per unit mass of radiator will be

$$\frac{8\pi}{3} \frac{Ne^4}{m^2} E. \quad \dots \dots \dots (79)$$

This equation obviously enables us to calculate the number of electrons contained in unit mass of the radiator, if the ratio E'/E of the scattered to the primary radiation can be measured.

Since it is found by experiment that the qualities of the scattered and the primary radiations are the same, the amount of ionization which they produce in a given volume of gas will be simply proportional to the energy of the rays. Thus we can compare their intensities by allowing them to enter in turn a suitable ionization chamber and observing the saturation currents produced. These currents will be proportional to the number of ions formed per second by the rays, that is, to the energy of the rays and thus

$$\frac{E'}{E} = \frac{i'}{i}$$

where i' and i are the two currents.

For a carbon radiator of unit mass the author found $E'/E = 0.27$. Assuming $e = 1.57 \times 10^{-20}$ e.m.u. and $e/m = 1.77 \times 10^7$, we have from (79) the number of electrons in one gram of carbon = 4.17×10^{23} .

Now the mass of a hydrogen atom is 1.64×10^{-24} gm. and that of a carbon atom, therefore, $12 \times 1.64 \times 10^{-24}$ gm. or 2×10^{-23} .

The number of carbon atoms in one gram of carbon is therefore $\frac{1}{2 \times 10^{-23}}$ or 5×10^{22} . The number of electrons contained in an atom of carbon is therefore $4.17 \times 10^{23} \div 5 \times 10^{22}$ or about **8**. It is thus slightly more than half the atomic weight.

Experiments seem to indicate that, at any rate for substances of small atomic weight, the energy scattered per unit mass is independent of the nature of the radiator. The number of electrons per atom is therefore proportional to the atomic weight.

85. Interference phenomena with X-rays. The identification of X-rays with light of short wave length naturally led to many attempts to detect variations in the intensity of the X-rays passing through narrow apertures, comparable with the effects obtained under similar circumstances with a beam of light. Haga and Windt in 1901 made experiments with a V-shaped slit, a few thousandths of a mm. wide at its narrowest end, and obtained certain variations of intensity in the resultant photograph which if really due to diffraction would indicate

a wave length of the order of 1.3×10^{-8} cm. The experiments are difficult and have never been accepted as decisive, although it is only just to say that the value obtained by these experiments has been confirmed* by the method of crystal reflection which we are about to describe. Similarly numerous attempts to obtain regular refraction or reflection with X-rays all led to negative results.

The obstacle in the way of regular refraction or reflection is evidently, if we are to accept Haga and Windt's estimate, the extreme shortness of the wave length of the rays. The ordinary reflection of light by a polished surface depends upon the possibility of rendering the irregularities of the surface negligible in comparison with the wave length of the light. It is obvious that for rays of wave length comparable with the diameters of the individual molecules this is no longer a possibility, and even the best optical surface must present to the Röntgen beam an appearance very like a layer of shot.

It is equally obvious that it would be hopeless to attempt to rule a grating which would produce appreciable diffraction in waves of this wave length. A beam of sodium light of wave length 5.89×10^{-5} cm. is deflected through an angle of some 19° by a grating with 5500 lines to the cm., that is, a spacing of 0.00018 cm. To produce a similar deviation in X-rays would require each of these spacings to be divided into ten thousand spaces, a process mechanically and physically inconceivable. It was not until 1912 that Prof. Laue conceived the idea that the regular grouping of the atoms in a crystal, as affirmed by modern crystallography, might provide a natural grating of suitable spacing for the experiment. The problem is of course much more complicated than that of the ordinary grating in which the spacings are all parallel and all in one plane. The regularity of the crystal grating is in three dimensions instead of only one and may be roughly compared to a pile of gratings one on the top of the other. The mathematical solution is far from simple if attacked directly as by Laue. However a solution was obtained. He showed that if a narrow pencil of X-rays was made to pass symmetrically through a crystal diffracted rays would emerge in various directions from the crystal and

would form a symmetrical pattern of spots arranged according to definite laws on a photographic plate placed perpendicular to the beam.

Laue not being an experimentalist, the theory was put to the test by Friedrich and Knipping in 1913, and emerged triumphantly. Their apparatus is indicated in Fig. 59. *F* is the anti-cathode of a powerful focus tube, and the rays are limited to a narrow pencil by passing through a series of slits in the lead screens *A*, *B*, *C*. They then fall on a crystal at *X*. A sighting screen *S* enables the adjustment to be made. A photographic plate is then inserted at *P* and an exposure made lasting for some hours. On developing the plate it was found that the very black central patch made by the undeflected beam of rays was surrounded by a symmetrical pattern of spots as

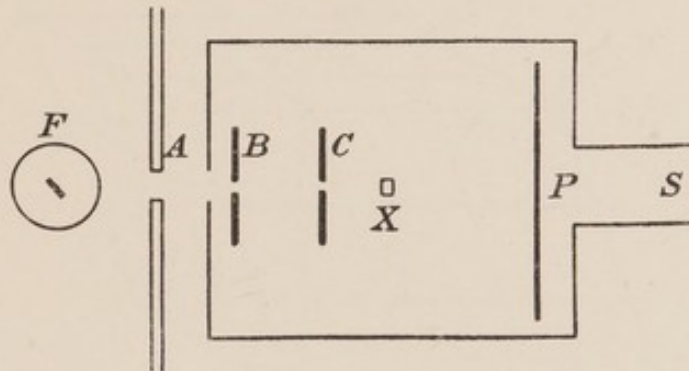

Fig. 59

indicated by the theory, some of the spots being deviated by nearly 40° from the direct line of the primary beam.

86. Theory of Laue's experiment. Modern crystallographers, following Bravais, have been led to regard the atoms in crystals as arranged with a definite spacial symmetry. All the atoms of the same sort are regarded as forming a regular system of points in space, the different systems belonging to the different atoms of course interpenetrating. This net-like arrangement is known as a space lattice.

In order that a set of points shall form one of these space lattices they must satisfy certain geometrical conditions. These conditions can be worked out irrespective of any definite knowledge of crystalline structure merely from the general laws to which all regular patterns in space must conform.

It has been shewn that the only method of dividing up space which will satisfy the conditions is as follows. A series of three sets of parallel planes is taken intersecting each other. All the planes in each set are parallel and equally spaced, but the spacings of the different sets need not be the same, and the planes may intersect at any angle. The space is thus divided up into a series of parallelepipeds (Fig. 60) the corners of which form a space lattice.

Let us for simplicity consider the special case, corresponding to the cubic system of crystals, in which the elementary parallelepipeds become cubes; that is, the three sets of planes are equally spaced and intersect at right angles. We have seen that an atom under the action of a Röntgen pulse becomes the centre of a secondary wave of disturbance which spreads out

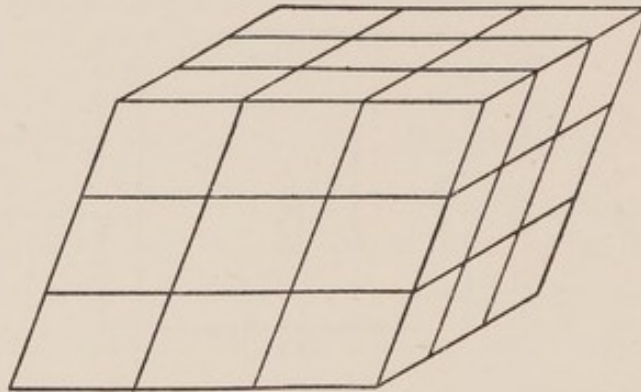

Fig. 60

through space. In fact each atom resembles very closely one of Huyghens' "elements."

Consider such an atom at O (Fig. 61) and take O as the centre of co-ordinates and the three directions of the space lattice as the axes. If the wave is passing in the direction OZ it will strike the three atoms O, A, B at the same moment. Let us consider the conditions which must be satisfied for the secondary wavelets from the four atoms O, A, B, C , to co-operate with each other in some direction OR . For the wavelets to co-operate they must arrive at a plane through C perpendicular to OR in phase with each other, that is, the different paths must each contain a whole number of wave lengths. These distances are $da, d\beta$, and $d(1 - \gamma)$ where a, β and γ are the direction cosines of OR and d is the side of the cube. Thus our condition

is that each of these distances shall be a whole number of wave lengths of the radiation used that is

$$\left. \begin{aligned} d\alpha &= p\lambda \\ d\beta &= q\lambda \\ d(1 - \gamma) &= r\lambda \end{aligned} \right\},$$

where p, q, r are whole numbers, representing the number of complete wave lengths in the given distances. Thus we have on reduction

$$\frac{\alpha}{p} = \frac{\beta}{q} = \frac{1 - \gamma}{r} = \frac{\lambda}{d} \dots \dots \dots (80)$$

Since p, q, r are integers, α, β and $(1 - \gamma)$ must bear to each other a simple ratio.

When this condition is fulfilled the secondary wavelets will reinforce each other in the direction OR and there will be a

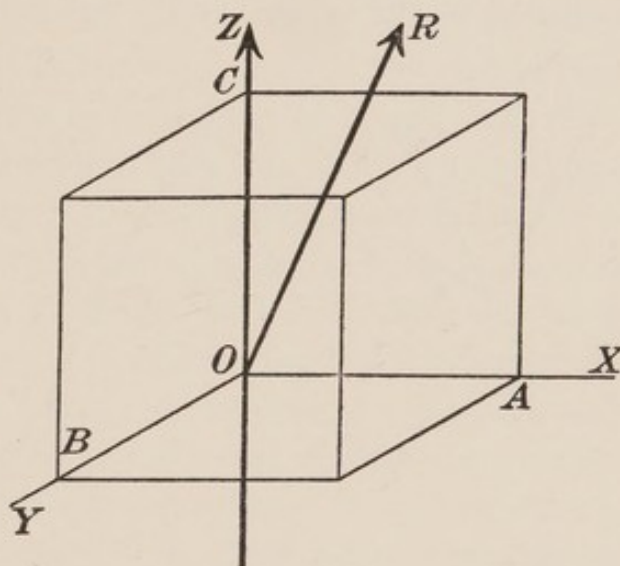

Fig. 61

spot on the photographic plate where this line meets it. From the position of the spot it will be possible to deduce the values of the direction cosines (knowing the distance of the plate from the crystal). Hence the theory can be brought to the test. On making the experiment it was found that in no case was it necessary to assign a greater value than 10 to the parameters p, q, r , in order to give to the quantities α, β , and $(1 - \gamma)$ an integral ratio.

The problem is really more complex than we have indicated, and the exact interpretation of the diffraction pattern obtained on the plate becomes a matter of some difficulty and uncertainty.

Fortunately a slight modification of the experiment can be made which gives not only a much simpler method of regarding the phenomena but also results capable of yielding more definite information.

87. Reflection of X-rays by crystal planes. Experiments of Bragg. Shortly after the publication of the work of Laue, W. L. Bragg discovered that X-rays could be regularly reflected by the cleavage planes of crystals when the rays were incident on the surface at nearly glancing angles. If we return to Fig. 60 it will be noticed that along certain planes drawn in the crystal, the construction planes, for example, the atoms are thickly studded, that is to say, these planes pass through a considerable number of molecules. It is possible to draw other planes in the crystal, such for example as those

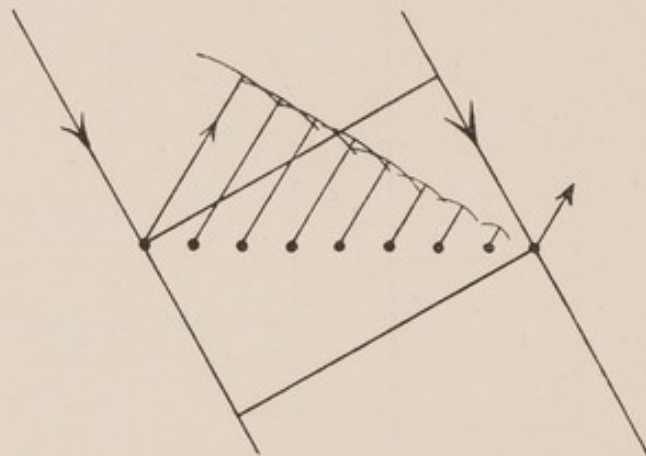

Fig. 62

drawn through opposite edges of the elementary parallelepipeds, which contain somewhat fewer but still considerable numbers of atoms. These planes are closely related to the surfaces of the natural crystal. They represent lines along which the crystal will cleave or split with comparative ease, and all are parallel to possible faces on the crystal. It is thus comparatively easy to identify them when the system of symmetry of the crystal is known.

Consider now a parallel beam of X-rays falling on one of these thickly studded planes represented in section by the dots in Fig. 62. As the wave front passes over each atom in turn, it becomes as we have seen the source of a secondary pulse

similar in character to that of the primary radiation. The separate secondary pulses will combine to form a wave front which at any appreciable distance from the plane will be practically plane, and will be inclined to the reflecting plane at an angle equal to that of the incident wave. We have in fact a reproduction of Huyghens' construction for the reflected wave from a plane surface, with the exception that in the case of light we regard the reflecting elements as perfectly continuous while in the case of X-rays owing to the much shorter wave length it is necessary to regard them as a finite number of definite points. The energy in the reflected wave, as we may call it, will obviously be proportional to the number of atoms per unit area in the plane.

There are many ways in which we can draw planes in the crystal but only in those few cases where the planes have some obvious relation to the symmetry of the crystal will these planes contain an appreciable number of atoms, and thus produce any appreciable reflection. Thus we may expect that when a beam of X-rays falls on a crystal the scattered radiation will be emitted in a comparatively few directions corresponding to the thickly studded planes in the crystal. For purposes of calculation we may regard these rays as having been reflected in the different sets of planes. It must be pointed out, however, that this reflection is a volume reflection taking place at all the planes in the crystal. It does not depend for its existence on any such plane on the surface of the crystal, nor indeed on the presence of any polished surface at all.

So far we have only considered the effect of a single plane. The energy scattered by a single plane, however, will be infinitesimally small, and it will only be in the case where the reflected rays from different parallel planes reinforce each other that the effect may be expected to be appreciable. It is owing to the fact that our crystal is in three dimensions and contains a series of planes one above the other all exactly similar, and parallel to each other, that any appreciable effect is produced.

Let pp, qq, rr, \dots (Fig. 63) be a series of such planes, and let PP'' be a wave front advancing on the crystal in the direction PQ , making an angle θ with the surface pp . It is obvious that

the reflected radiation will be most intense if all the waves from the successive layers reach R in the same phase, that is, if the difference in path of the rays $P'Q'Q$ and PQ is a whole number of wave lengths. Draw QSN perpendicular to pp and QD perpendicular to $P'N$. Then since PQ and QR make equal angles with the line pp , and QN is perpendicular to pp , $Q'Q$ is equal to $Q'N$ and the path difference between the two rays under consideration is $P'Q' + QQ' - PQ = P'Q' + Q'N - P'D$

$$\begin{aligned} &= DN \\ &= QN \sin \theta \\ &= 2d \sin \theta (81) \end{aligned}$$

where d is the perpendicular distance between the planes. Hence the condition for maximum reflection at any crystal

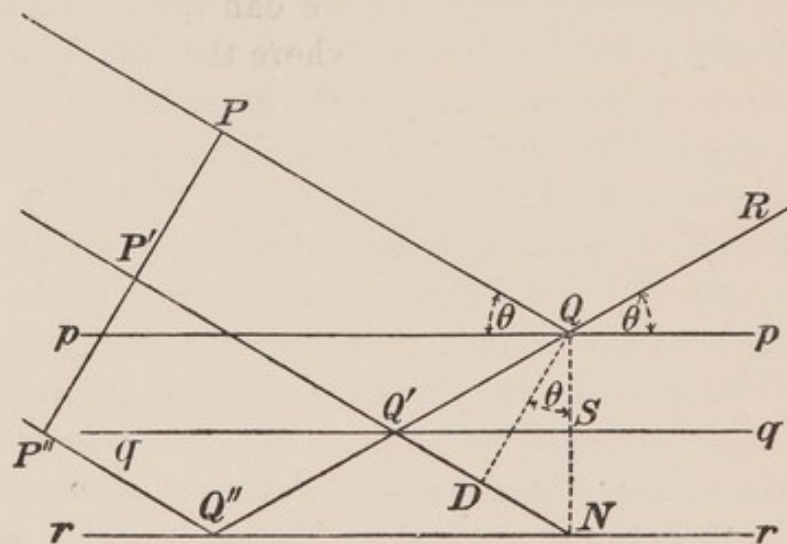

Fig. 63

face is that $2d \sin \theta$ shall be an integral number of wave lengths of the radiation used.

It will be noticed that the problem is exactly analogous to that of the diffraction grating, the various parallel planes acting as lines in the grating. Applying the usual optical principles it can be shewn that a very small discrepancy from exact agreement in phase between the separate elements will result in the almost complete extinction of the radiation by interference. The reflected image will therefore be very sharp just as in the case of the grating. Also, exactly as in the case of a grating, each particular wave length will be reflected at some single definite angle.

If the primary X-radiation is homogeneous there will obviously be a series of directions along which the radiation will be reflected, these being obtained by making n successively equal to 1, 2, 3, . . . in the general equation

$$2d \sin \theta = n\lambda, \quad . \quad . \quad . \quad . \quad . \quad (82)$$

where λ is the wave length. These will correspond to the spectra of different orders produced by a grating, and may be alluded to as the first, second, etc., order reflection spectra. These spectral lines can be identified as belonging to the same primary wave length by the fact that $\sin \theta_1 : \sin \theta_2 : \sin \theta_3 : \text{etc.} :: 1 : 2 : 3 \dots$

The method obviously gives us a means of comparing the wave lengths constituting our primary beam. For if we allow two beams of wave length λ and λ' to fall on the same face of the same crystal they will suffer reflection at angles θ and θ' respectively, such that $2d \sin \theta = n\lambda$, $2d \sin \theta' = n\lambda'$. Hence for the same crystal and the same order of reflection we have

$$\frac{\lambda}{\lambda'} = \frac{\sin \theta}{\sin \theta'} \quad . \quad . \quad . \quad . \quad . \quad (83)$$

Thus if our primary beam is made up of a number of definite wave lengths, there will be a series of definite angles at which we shall obtain sharp reflection of the rays, each angle corresponding to some definite wave length. If on the other hand the X-rays form a continuous series of wave lengths, there will be a certain range of angles between which reflection will take place. This corresponds to the case of the continuous spectrum formed by a grating with white light, and the radiation may conveniently be referred to as "white" X-radiation.

It is obvious that the phenomenon is confined to certain definite small limits. Since the maximum value of $\sin \theta$ is unity, then $n\lambda/2d$ must be less than 1. Thus reflection will only take place when n is sufficiently large and d sufficiently small. In very favourable cases, using the principal planes of the crystal d may be as much as five times λ , in which case as many as ten spectra may be observed. The intensity however as in the case of an ordinary grating decreases rapidly with the order of the spectrum. It is found experimentally that the

distance apart of the planes decreases rapidly as the planes become less fundamental, and eventually becomes so small that there are no values satisfying equation (82) for the wave lengths generally present in a Röntgen beam.

It is evident that if we keep λ constant and use different planes as reflecting planes we can find the relative values of d for the various crystal systems and thus obtain much light on crystal structure.

88. The X-ray spectrometer. The different angles at which reflection can occur may be investigated either by a photographic or by an ionization method, and each has been used by different investigators. The apparatus needed for the ionization method has been perfected by W. H. Bragg and is

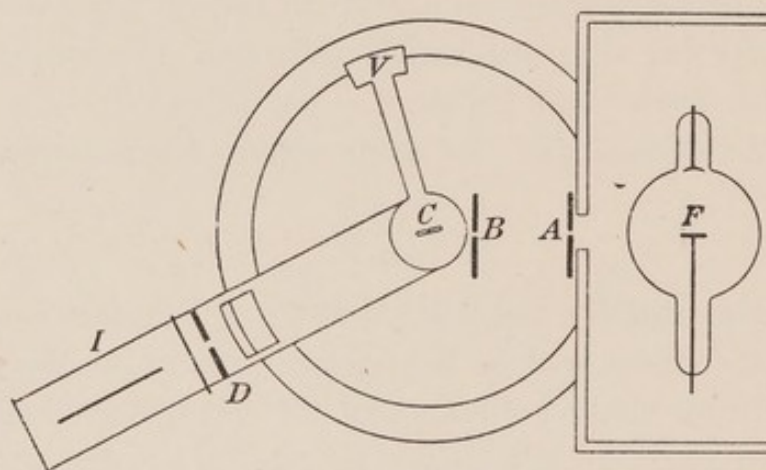
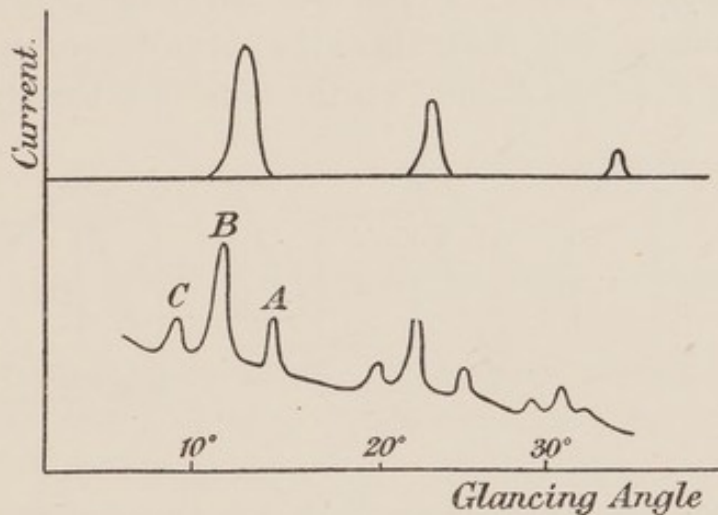

Fig. 64

indicated in Fig. 60. The rays from the anti-cathode of the X-ray tube are limited to a narrow pencil by two lead slits *A* and *B*. These are adjustable by a screw and their width can be read on a suitable scale attached to the screw. The arrangement may be compared to the collimator of a telescope. The crystal is mounted on the table of the spectrometer, as we may call it, at *C*, and its orientation may be read by the vernier *V* on the circular scale of the instrument. The ionization chamber *I* is carried by an arm also pivoted at the centre of the instrument, and the reflected beam can be limited by a third lead slit *D*. The current through the ionization chamber can be measured by electroscopes or electrometers in the usual way. As the intensity of the reflected ray is usually small the

ionization chamber is generally filled with some heavy gas such as sulphur dioxide, in which the ionization produced by a given beam of X-rays is more intense than it is in air. If a photographic method is preferred a photographic plate is substituted for the ionization chamber.

In using the apparatus the crystal and the chamber are moved together, the latter of course being always moved through twice the angle of the latter. As the glancing angle between the crystal face and the incident beam is gradually increased a point is reached where the electroscope shews a deflection, and the ionization current can be plotted against the glancing angle. If the rays are homogeneous the X-rays will only enter the chamber and the current will only flow at certain definite angles



Figs. 65 & 66

corresponding to the different order of spectra for that particular wave length, and the curve will be discontinuous.

This case is represented by the curve of Fig. 65, which shews the current through the chamber against the glancing angle θ . It will be seen that the curve shews three peaks or "lines," and these three peaks can be identified as being due to the same waves by the fact that $\sin \theta_1 : \sin \theta_2 : \sin \theta_3$ as $1 : 2 : 3$. In general, however, if the radiation is that from an ordinary X-ray tube, it will be made up of numerous rays of definite wave lengths together with more or less "white" radiation or radiation of continuous wave length. The curve will then be a continuous curve rising to various peaks or

maxima, the height of which affords a rough measure of the intensity of the corresponding wave length in the primary beam. This is shewn in Fig. 66 which gives the curve for the radiation from a platinum anticathode. It will be seen that in this very important practical case the rays consist of a mixture of three special wave lengths which are characteristic of platinum, on a background of "white" radiation. If the turning is continued these three peaks appear again in the second order reflections, and again in the third order. It will be noticed that the intensity decreases with the order of the spectrum. These three peaks are characteristic of the platinum anticathode. They reappear whatever the nature of the crystal used for the reflection; rock salt, iron pyrites, fluorspar, etc., all yielding the same result. The curves are in fact exactly similar in the three cases, only the scale of the curve depending, as might be expected from the theory, on the nature of the crystal used.

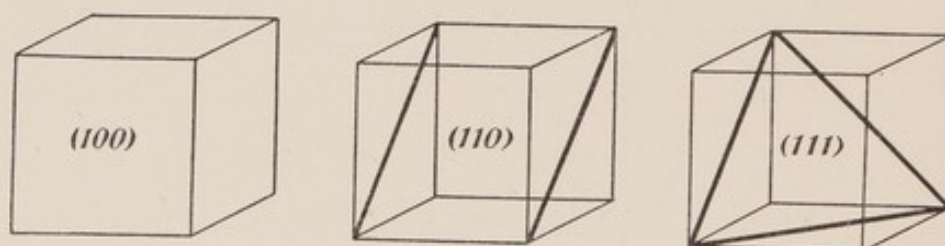

Fig. 67

89. **Determination of the wave length of X-rays.** The theory so far developed only enables us to compare wave lengths. To determine them in absolute units we must know the distance apart of the planes in our crystal grating. The discussion involves some acquaintance with elements of crystallography, but the argument is briefly as follows.

Taking the case of a simple cube (Fig. 67), the most important faces are (1) the face of the cube itself, (2) the face parallel to a plane through opposite edges of the cube, (3) the face parallel to a plane including one corner of the cube and passing through the diagonal of the opposite face. The development of this face gives rise to regular octahedra and is exceedingly common on cubic crystals. The three sets of planes are denoted in crystallography as $\{100\}$, $\{110\}$, and $\{111\}$, respectively.

Now crystallographers recognize three classes of cubic symmetry,

(1) the simple cube arising from a simple cube lattice such as we have already described,

(2) a cube with a single particle at the centre, known as the cube centred lattice,

(3) a simple cube with a particle at the centre of each face: this is known as the face centred lattice.

Now the ratios of the distances between two successive planes for the three sets of planes corresponding to the systems $\{100\}$, $\{110\}$, $\{111\}$ will not be the same for the three kinds of lattices. It can be shewn by simple geometry that

$$\begin{aligned} \frac{1}{d_{100}} : \frac{1}{d_{110}} : \frac{1}{d_{111}} \\ &= 1 : \sqrt{2} : \sqrt{3} \text{ for simple cube lattice} \\ &= 1 : \frac{1}{\sqrt{2}} : \sqrt{3} \text{ for a cube centred lattice} \\ &= 1 : \sqrt{2} : \frac{\sqrt{3}}{2} \text{ for a face centred lattice.} \quad (84) \end{aligned}$$

Now by using the same homogeneous X-radiation for the three faces $\{100\}$, $\{110\}$, $\{111\}$ respectively we can by (81) find the ratios of $d_{100} : d_{110} : d_{111}$. We can thus identify for any given crystal, by applying the above results, the particular order of cube symmetry to which the crystal belongs.

Let us apply these results to the important sylvine group, comprising rock salt (NaCl), sylvine (KCl) and the corresponding bromides and iodides. These are chemically and crystallographically similar and may reasonably be expected to have the same structure. In the case of sylvine the measurements would indicate that it has the simple cubic structure. With rock salt, however, we meet a new phenomenon. The reflections from the $\{111\}$ faces give a weak first order spectrum, a strong second, a weak third, a strong fourth, and so on. Judging only by the strong spectra we should assign to rock salt the simple cube lattice. Judging by the weak first order spectrum it would be a face centred lattice. How are the two

results to be reconciled with each other and with the result for the crystallographically identical sylvine?

W. L. Bragg made the suggestion that the points making up the crystal structure were not molecules but atoms of the constituents of the salt. Now we know that the intensity of the scattered radiation from an atom is proportional to the number of electrons in it and therefore to the atomic weight. Thus the reflections from the sodium planes ($\text{Na} = 23$) will be comparatively weak and those from the chlorine planes ($\text{Cl} = 35.4$) will be comparatively strong. There will, however, be no such

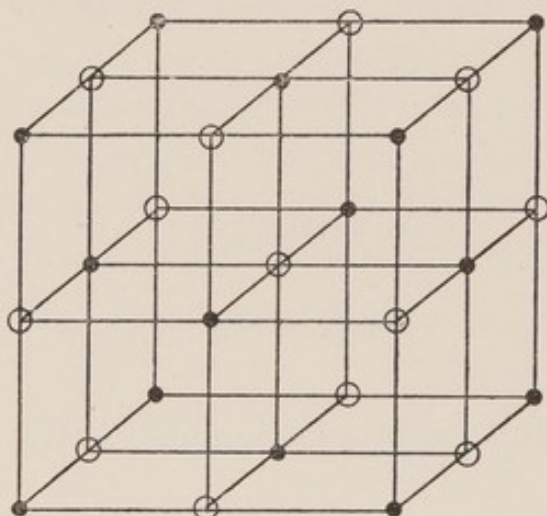

Fig. 68

difference in the case of sylvine, since the atomic weight of potassium (39) is very near that of chlorine. He found that all the results could be accounted for by assigning to both crystals the structure indicated in Fig. 68, the metallic atoms being represented by dots, the chlorine atoms by circles. If the dots and the circles produce identical effects as is practically

the case with sylvine, the system becomes a simple cube lattice. When the particles are different, however, the case corresponds to that of an optical grating in which every odd ruling is made somewhat wider than the even ones. In this case, as we know, a second set of spectra corresponding to a grating with twice the actual grating space appears, superimposed upon the normal spectra, the deflection of the first order spectrum being approximately half that of the normal first order spectrum.

Accepting this structure for the rock salt crystal we see (considering the adjacent cubes in all directions) that each sodium atom is associated with eight of the small cubes into which the figure can be divided, and assuming its mass to be equally divided among the cubes, one-eighth of the mass is included in each cube. There are four sodium atoms associated with each small cube and thus each small cube includes the

mass of half an atom of sodium, and therefore half a molecule of the compound sodium chloride. Thus the whole structure of Fig. 68 represents four molecules.

The distances apart of the planes bounding the small cubes is obviously d_{100} , all the planes being exactly similar. Hence the volume of each small cube is $(d_{100})^3$. The mass associated with each small cube is one half that of the sodium chloride molecule, that is $\frac{1}{2}(23 + 35.5) \times$ (the mass of the hydrogen atom). The mass of the latter as we have already seen (§ 25) is 1.64×10^{-24} gm.

Hence if ρ is the density of the rock salt crystal ($= 2.17$) the mass of the cube $= \rho (d_{100})^3 = 29.3 \times (1.64 \times 10^{-24})$

and $d_{100} = 2.80 \times 10^{-8}$ cm.

For the most pronounced radiation from platinum the glancing angle for the first order spectrum using the d_{100} planes of rock salt is 11.4° . Hence substituting in the equation $\lambda = 2d \sin \theta$ the wave length of this particular X-radiation is given by

$$\lambda = 1.10 \times 10^{-8} \text{ cm.}$$

90. The X-ray spectra. By means of the X-ray spectrometer we can measure the wave lengths of the X-radiation emitted by an anticathode when bombarded by cathode rays. By using anticathodes of different materials the X-ray spectra of the different elements can be investigated. To avoid the necessity of making and evacuating a large number of tubes the various anticathodes are mounted on a sort of trolley which can be controlled from outside the tube by a magnet. By moving the trolley the various anticathodes can be brought in turn into the path of the cathode rays and their emission investigated.

It is found that under suitable circumstances each element emits when used as an anticathode an X-ray spectrum which is as characteristic of the element as the light spectrum itself, while the phenomena are much simpler and their relationships more evident than in the case of the visible spectra of the elements.

Taking first the case of elements with a smaller atomic weight than that of silver (108) it is found that in each case the X-rays

emitted are of two definite and not very different wave lengths. The X-ray spectrum of these elements, therefore, consists of what we may term by analogy, a single doublet. The element of the doublet of greater wave length has the greater intensity.

The relation to ordinary spectra is more obvious if the ionization chamber of the spectrometer is replaced as in the experiments of Moseley by a photographic plate. In this case the two radiations register themselves on the plate as two lines, one faint and one intense, side by side. The method can also be used for analysis, just as in the case of the visible spectrum, brass for example shewing the lines both of copper and of zinc.

As we proceed from elements of lower to elements of higher atomic weight the wave length of the characteristic radiation decreases, and an examination of the numerical results shews that there is a simple relation between the frequency of the characteristic radiation and the atomic number of the element*. It is found that to a considerable degree of accuracy the frequency of the radiation emitted is directly proportional to the square of the atomic number. Thus

$$(\text{frequency}) \propto (\text{atomic number})^2. \quad (85)$$

The radiations with which we have been dealing form what is known as the *K* series of characteristic radiations. The existence of these characteristic radiations had been recognized before the development of the X-ray spectrometer, as they can be distinguished and identified by their absorbability in some substance such as aluminium, the absorbability decreasing with the wave length. Before the method of crystal reflection had been discovered they were particularized by the name of the element emitting them. Thus the principal X-radiation emitted by silver and having a wave length 0.560×10^{-8} was spoken of as the silver radiation, and so on. This nomenclature is

* The atomic number of an element is its number in the series of the elements arranged in order of ascending atomic weights. Thus hydrogen is 1, helium 2, lithium 3, and so on. Except in the case of hydrogen the atomic number is not far removed from one-half of the atomic weight. It is found that the various relationships between the atomic properties become much more exact when the atomic number is substituted for the atomic weight. We are thus led to regard the atomic number as more fundamental than the atomic weight, the variation of the latter from twice the atomic number being regarded as due to secondary and relatively unimportant causes which have yet to be elucidated.

convenient and will probably be retained. It is analogous to the method adopted by spectroscopists of referring to light of wave length 5.89×10^{-5} cm. as sodium light.

The elements from zirconium (90) to gold (196) give rise to an additional series of radiations, also consisting of a strong and weak component known as the *L* series. For these also the frequency is proportional to the square of the atomic number but the constant of proportionality is not the same for the two series. It will be noticed that the two series overlap so that elements from zirconium to silver emit radiations belonging to both series, the complete spectrum for these elements thus consisting of two doublets. For the same element the *L* series has a greater wave length than the *K* series and the rays are consequently much less penetrating. For silver for example the *K* radiation has a wave length 0.560×10^{-8} , the *L* 4.17×10^{-8} .

The present limits to the two series are due to experimental difficulties and each will no doubt be extended in both directions. The *K* series for elements of higher atomic weight than silver is difficult to excite, because, as we shall see later, the velocity of the cathode rays necessary to excite a given radiation increases with the frequency of the radiation. On the other hand the *L* radiation from elements of low atomic weight is difficult to observe on account of its great absorptivity.

In addition to the *K* and *L* series there is evidence of at least one, and probably more, similar series. The X-ray spectrum is at present very far from having been completely mapped.

Since the *K* and *L* series correspond to lines in an optical spectrum we should expect some relationship between them. It has been pointed out that if an element of atomic weight A_K emits *K* radiation of the same wave length as the *L* radiation emitted by an element of atomic weight A_L then

$$A_L = \frac{1}{2} (A_K - 48). \quad (86)$$

If this relation is universally true it follows that no element of atomic weight less than 48 can give out radiation belonging to the *L* series.

In addition to the radiation characteristic of the element the anticathode in an X-ray tube emits a considerable amount of general or "white" radiation, the average wave length of which decreases as the potential across the tube is increased. In many cases, for example in platinum which is very generally employed as an anticathode, the total intensity of the "white" radiation is large compared with that of the characteristic platinum lines (see Fig. 66). In tubes of this sort therefore the average frequency and consequently the average penetrating power of the rays increases as the potential across the tube is increased. Penetrating and absorbable rays are generally referred to by radiographers by the terms "hard" and "soft" respectively.

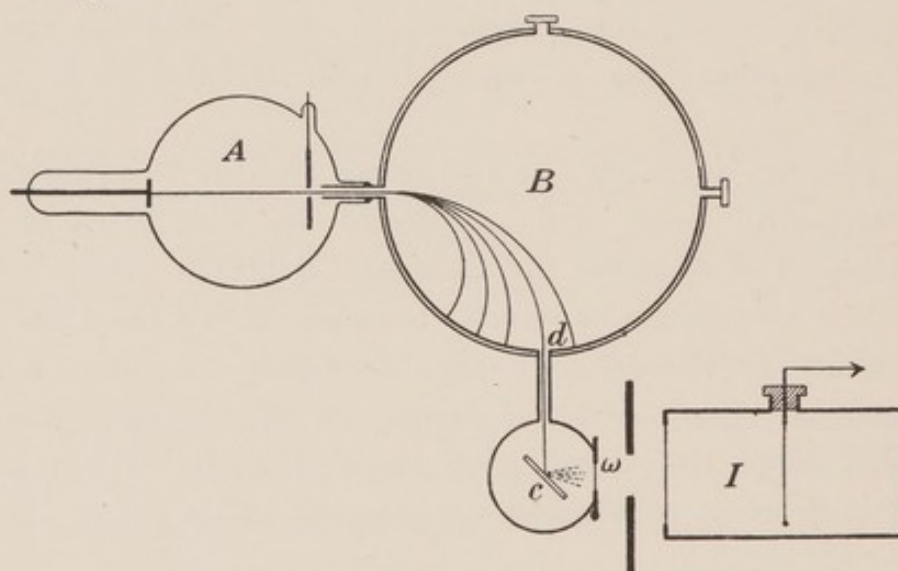

Fig. 69

91. Conditions for the excitation of characteristic radiation. It is found that the characteristic radiation of a given element when used as an anticathode will only be excited if the incident cathode rays reach a sufficiently high velocity. For cathode rays of smaller velocity than this only the "white" radiation is given out. The matter has been investigated by Whiddington using apparatus similar to that shewn in Fig. 69.

The cathode rays were generated in the bulb *A*, and passed through a narrow hole into the brass cylinder *B* which was wound as a solenoid. By sending suitable currents through the solenoid magnetic fields of calculable intensity could be applied at right angles to the path of the rays, which were deviated by

amounts depending on their velocity, and thus spread out into a magnetic spectrum each line of which corresponded to some definite known velocity of the cathode particles. By suitably adjusting the field, particles of any required velocity could be made to fall on the small hole d and so on to an anticathode at c . The X-rays generated passed out through a thin aluminium window ω into an ionization chamber I . If the incident cathode rays were too slow to excite the characteristic radiation of the radiator a certain amount of "white" radiation passed into I . This, however, was always largely increased when the characteristic radiation was excited and so a sharp increase in the ionization current occurred when the cathode rays reached the critical velocity.

It was found that for every element there was a definite critical velocity which must be attained by the cathode rays before the characteristic radiation was excited. This critical velocity was found to be proportional to the atomic number of the element. For the K series the minimum velocity of cathode ray which will stimulate the characteristic radiation in an element of atomic number A is expressed by the relation

$$V_K = 2A \times 10^8 \text{ cm. per sec.} \dots \dots (87)$$

Combining this with (86) we have for the L series

$$V_L = (A - 48) \times 10^8 \text{ cm. per sec.} \dots \dots (88)$$

Since the mass of an electron is approximately 9×10^{-28} gm. the energy necessary to excite, say the nickel K radiation, is $\frac{1}{2} (9 \times 10^{-28}) \times (56 \times 10^8)^2$ or about 1.4×10^{-8} ergs.

The energy necessary to excite a given radiation is by (87) proportional to the square of the atomic weight. The frequency of the characteristic radiation is also proportional to the square of the atomic weight (85). Hence the energy required to excite an X-ray of given frequency is proportional to the frequency, a result which is in agreement with Planck's theory described in the previous chapter.

The frequency of the nickel radiation is 1.8×10^{18} . Substituting in Planck's equation $E = hn$, the quantum of energy for the nickel ray is $(6.55 \times 10^{-27}) \times (1.8 \times 10^{18})$ or 1.2×10^{-8} . This agrees with the direct measurement given above as well as could

be expected from the difficulties involved in the various measurements.

92. Characteristic secondary radiation. The radiation characteristic of the different elements may be excited not only by the impact of cathode rays but also by the action of a beam of X-rays from an X-ray bulb, providing that the latter are of suitable wave lengths. The rays so excited may be described as characteristic secondary rays, to distinguish them from the purely scattered secondary radiation already described.

Much work had already been done on these characteristic secondary rays by Barkla and others, before the phenomena of crystal reflection gave us a means of actually measuring their wave lengths. In order to identify the different radiations their absorbability in a light substance such as aluminium was used as a test both of their homogeneity and of their wave length.

The absorption of a beam of homogeneous rays is an exponential function of the thickness of the absorbing substance so that we have

$$I = I_0 e^{-\lambda d}, \quad (89)$$

where I_0 is the original intensity of the beam, I its intensity after passing through a thickness d of the substance, and λ a constant known as the coefficient of absorption depending on the nature of the absorbing substance and the wave length of the radiation. Experiments recently made with homogeneous beams of known wave length have shewn that the coefficient of absorption λ decreases with decrease in the wave length, the relation being

$$\text{coefficient of absorption} \propto (\text{wave length})^{\frac{5}{2}}. \quad . . (90)$$

It can thus be used as a test of the quality of the rays.

If the absorption of a beam of X-rays is measured using different thicknesses of the absorbing substance we can get a rough test of the homogeneity of the beam. If we have a primary beam of rays containing both hard and soft rays the latter will be absorbed by the first few thicknesses of material while the former being more penetrating will be largely transmitted. The beam will thus become relatively richer in the more pene-

trating components as it passes through greater thicknesses of material, and hence its absorption will not follow an exponential law. It was found by Barkla that the absorption of the primary rays from an ordinary focus tube was not exponential, and the rays were thus presumably complex. It was found, however, that the secondary radiation given out by a copper radiator for example when illuminated by a beam of primary X-rays was absorbed very accurately according to an exponential law, and was, therefore, homogeneous. For this reason the characteristic secondary radiation from a radiator is often described as its "*homogeneous radiation*". As we have seen, neither series of characteristic radiations is strictly homogeneous, as the lines are all doublets. As, however, the two components of the doublet are not very different and one is comparatively weak we should not expect to disentangle them by the comparatively crude absorption method.

In this way the existence of the two series of radiations was recognized, and the characteristic *K* radiations of all the elements from sulphur to barium, and the *L* radiations from silver to bismuth investigated and their absorption coefficients in aluminium determined. Aluminium is used as a standard of absorption because in the first place it can readily be obtained in sheets of any required thickness, and in the second place owing to its small atomic weight its own characteristic radiations are not excited in appreciable quantity and thus do not interfere with the results.

It was found as a result of these investigations that the coefficient of absorption in aluminium of the characteristic radiation of a given element was inversely proportional to the fifth power of the atomic weight. This follows directly from the laws already stated; the coefficient of absorption being proportional to $(\text{wave length})^{\frac{5}{2}}$ while the wave length of a characteristic ray is inversely proportional to the square of the atomic weight of the element emitting it.

It is found that in order to excite the characteristic radiation in an element it is necessary that the incident primary beam should have a shorter wave length than that which it is wished to excite. Thus the radiation from copper cannot be excited

by the characteristic radiation from nickel, or even by the characteristic radiation from copper itself. It is, however, excited by the characteristic radiation of zinc, which of course has a slightly shorter wave length. The analogy with the phenomenon of optical fluorescence is obvious, and on this account some writers refer to the characteristic secondary radiation as the *fluorescent* radiation.

These phenomena can easily be studied by the simple apparatus illustrated in Figure 70. The primary rays from a focus tube F fall on a radiator R_1 and thence through an aperture in a lead screen L on to a second radiator at R_2 . The radiation

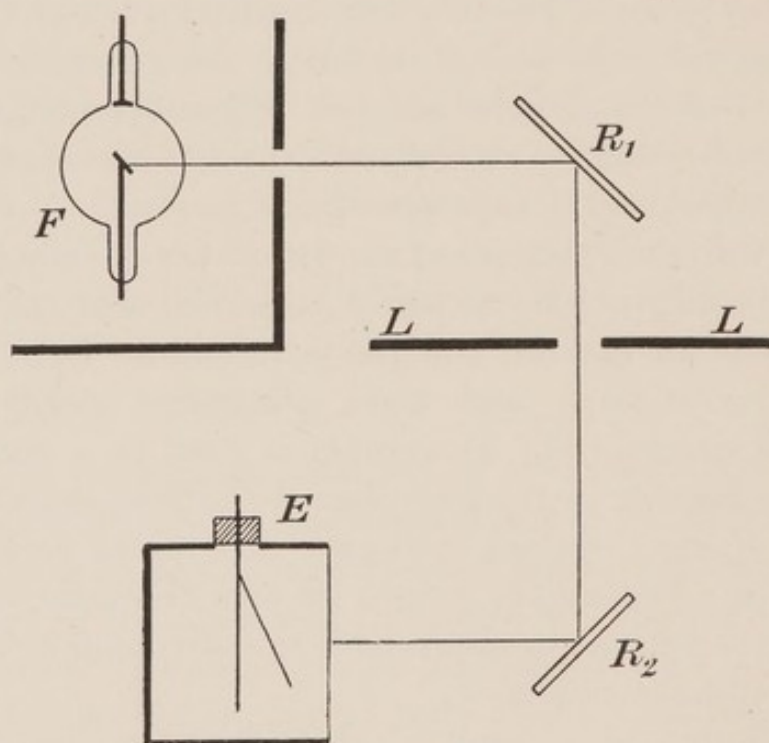

Fig. 70

from R_2 can be measured by a gold leaf electroscope of simple type placed at E out of the direct line of the rays from R_1 . The purely scattered radiation from R_2 is generally too weak to produce any appreciable ionization in E , the energy scattered by a radiator being normally only a very small fraction (1 per cent. or so) of that which it emits when its fluorescent radiation is excited. If, however, the radiation from R_1 is of suitable quality to excite the characteristic radiation in R_2 the electroscope will lose its charge at a rate which is proportional to the intensity of the fluorescent radiation from R_2 . Thus if R_2 is

copper and R_1 is nickel there will be practically no effect on the electroscope E , but if the nickel radiator is replaced by one of zinc a large effect is obtained. By placing aluminium screens of various thicknesses in front of E , the coefficient of absorption of the rays can be measured, and most of the measurements, hitherto obtained, have been obtained in this way. It is now, however, both more accurate and more convenient to isolate radiation of the particular wave length required by means of the X-ray spectrometer and to measure its absorption coefficient by placing the aluminium screens in front of the ionization chamber I (Fig. 64) when the spectrometer is adjusted.

It has been shewn by the author that unlike the scattered radiation the homogeneous radiation is emitted uniformly in all directions round the radiator.

93. The absorption of X-rays. The absorption of a beam of homogeneous X-rays is as we have seen expressed by the relation

$$I = I_0 e^{-\lambda d}$$

where λ is the coefficient of absorption. If the wave length of the radiation is not too close to that of the characteristic radiation from the substance we are using to absorb the rays experiment has shewn that

$$\lambda \propto (\text{wave length})^4. \quad (91)$$

Further, if we keep to radiations of the same wave length, and use different absorbing screens, then so long as in each case the wave length is not too close to that of the radiation characteristic of the absorbing screen, it is found that the coefficient of absorption in the substance is proportional to the fourth power of its atomic weight.

It is obvious from a consideration of the facts of the emission of the fluorescent radiation that these laws cannot hold throughout the whole spectrum. The energy of the fluorescent secondary radiation must come from the primary rays, and hence the absorption when the secondary rays are excited must be considerably greater than in the case where the incident waves are unable to produce this emission. There will thus be certain critical values of the primary wave length for each substance at which the coefficient of absorption experiences a sharp change.

Suppose for example we take the case of the absorption by different elements of the radiation characteristic of nickel. This will excite the characteristic K radiation in all elements of lower atomic weight than its own, and the coefficient of absorption of the nickel rays in these substances will be high. It is found to vary as the fourth power of the atomic weight of the absorbing substance. On reaching nickel itself the K radiation is no longer excited in the absorbing element. Thus less energy is absorbed from the primary beam, and the coefficient of absorption is much reduced. Nickel is exceptionally transparent to its own radiation.

After this critical point is passed the absorption again

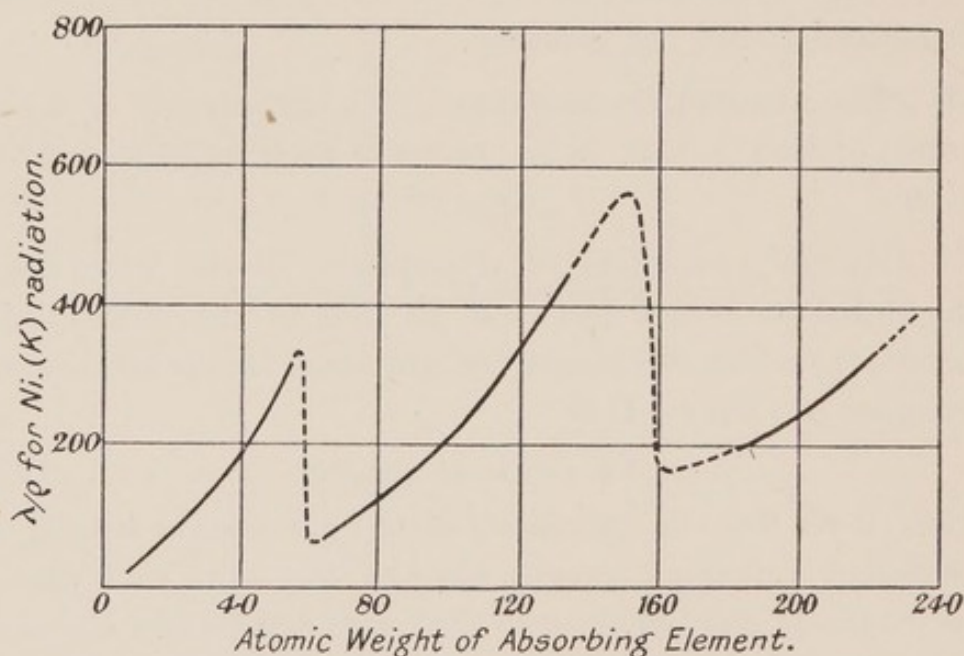

Fig. 71

increases with the fourth power of the atomic weight of the absorber, but with a smaller coefficient of proportionality. The K radiation in these elements is not excited but the L radiation is, and energy is thus withdrawn from the primary beam. Eventually we come to some element for which the nickel radiation is unable to excite the L radiation also. Applying the relation (86) between the two series we see that this would occur for an element of atomic weight about 167, that is one of the rare earths. Here again, as the L radiation is not now excited, there is a large fall in the absorption coefficient. From

this point the absorption again increases with the fourth power of the atomic weight of the absorbing substance but with the proportionality factor again reduced.

The complete curve between absorption and the atomic weight of the absorber for X-rays of definite wave length thus takes the form shewn in Fig. 71. The separate parts of the curve each obey the fourth power law, but with different constants of proportionality. There is thus nothing which exactly corresponds to a definite absorption band such as we get in the visible spectrum.

The absorption of the rays in a given substance is independent of its state of concentration. Thus for a given substance the ratio λ/ρ , where ρ is the density, is constant. On this account the absorption of the rays is generally expressed in terms of this ratio.

Table VI, which contains the universal values of wave length and coefficient of absorption of the characteristic radiations for a number of different elements, may be studied in conjunction with the foregoing account.

TABLE VI

Wave lengths and absorption coefficients of characteristic X-rays

<i>Element</i>	Wave length of characteristic radiations ($\times 10^{-8}$ cm.)				λ/ρ (<i>K</i> series)	
	<i>K</i> series		<i>L</i> series		in Al	in Cu
	<i>a</i>	β	<i>a</i>	β		
Al	8.36	7.91	—	—	—	—
Ca	3.37	3.09	—	—	—	—
Cr	2.30	2.09	—	—	136	143
Fe	1.95	1.77	—	—	88.5	95.1
Co	1.80	1.63	—	—	71.6	75.3
Ni	1.66	1.51	—	—	59.1	61.8
Cu	1.55	1.40	—	—	47.7	53.0
Zn	1.45	1.31	—	—	39.4	55.5
As	—	—	—	—	22.5	176
Zr	0.79	—	6.09	—	—	—
Mo	0.72	—	5.42	5.19	4.8	40.3
Ag	0.56	—	4.17	—	2.5	24.3
Sn	0.50	0.43	3.62	—	1.57	—
Sb	0.48	0.41	3.46	3.25	1.21	—
W	0.20	0.18	1.49	—	—	—
Pt	—	—	1.32	1.12	—	—

94. **Secondary corpuscular radiation.** In addition to the scattered and homogeneous secondary radiations which are themselves X-radiations, a beam of X-rays when falling on a substance also gives rise to a very easily absorbable radiation which can be deflected by a magnetic field, and can thus be shewn to consist of negatively charged electrons. The velocity of these electrons can be measured by the application of equation (37). These corpuscular rays are all absorbed within a cm. or so of gas, and hence the ionization they produce is very intense.

The electrons are not emitted equally in all directions. If a very thin radiator is used (such as a sheet of gold leaf) it is found that, just as in the case of the scattered radiation, considerably more of the corpuscular radiation emerges on the emergence side than on the incidence side of the radiator. The electrons are, therefore, projected from the atom with a component velocity in the direction of the primary beam.

Taking the theory of X-rays already propounded, the electric force in the primary pulse will be at right angles to its direction of propagation. The electrons will, therefore, have an acceleration in this direction, which if their attachment to the atom is sufficiently weak will cause them to be projected in this direction, that is at right angles to the primary beam. This lateral projection is extremely well shewn in photographs taken by the expansion method of C. T. R. Wilson and shewn in Fig. 18. The primary beam which is invisible, passes across the gas from left to right. The tracks of the electrons ejected by the rays are revealed by the condensation of water upon them. It will be seen that each of these tracks begins nearly normal to the line of the beam.

There is however a magnetic field in the pulse, so that when the particles have been projected they are acted upon by a magnetic field. It is easy to shew that the direction of this field will be such as to deflect the particles towards the direction in which the primary X-rays are travelling. In addition to their lateral velocity the particles will thus have a component in the direction of the primary rays.

The matter can easily be dealt with numerically by Planck's

theory. The energy absorbed by the electron is hn where n is the frequency. Since this energy was travelling with a velocity c in the direction of the rays it has a momentum hn/c which is also absorbed by the electron. Hence if u is the forward velocity of the electron and m its mass we have

$$mu = \frac{hn}{c} \dots \dots \dots (92)$$

But if v is the velocity of projection due to the absorbed energy hn

$$\frac{1}{2}mv^2 = hn.$$

$$\therefore \frac{u}{v} = \frac{v}{2c} \dots \dots \dots (93)$$

For the particles projected by X-rays v is of the order of 10^{10} cm. per sec. Thus $u/v = \frac{1}{6}$, which is approximately the value obtained by direct experiment.

Since the electrons are projected mainly in a sideways direction, the fact that they emerge from both surfaces of the radiator is due to the deflections they suffer during collision with the molecules of the radiator. Since, however, they have a component of velocity in the forward direction there will always be a preponderance of electrons on the emergence side of the radiator.

The velocity of emission of the corpuscular rays is independent of the nature of the substance in which they are formed and depends only on the frequency of the incident X-radiation. Using homogeneous beams of known wave length it can be shewn by experiment that the velocity of emission of the electrons varies directly as the square of the frequency of the exciting rays. But we have already seen that the velocity which the primary cathode rays must have in order to excite radiation of given frequency is proportional to the square of the frequency. Hence the velocity of the secondary electrons emitted from the radiator should be proportional to the velocity of the cathode rays which gave rise to the primary radiation used.

On making the actual experiments it is found that within the limits of experimental error the velocity of the corpuscular radiation which is excited when X-rays fall on a radiator is

identical with the velocity of the cathode rays used to excite the X-radiation. Since the masses of the two electrons are identical it follows that their energies must be the same. Hence we have the remarkable result that an X-ray pulse is able to concentrate at any distance from its point of origin the whole of its original energy upon a single electron, a result for which the older theories of radiation offer no explanation. We are thus led again to the point which we reached in our discussion of the photo-electric effect (§ 73).

95. Ionization by X-rays. The ionization of gases by X-rays has been frequently referred to, being the property usually employed to measure the intensity of the rays. The number of ions so formed is never more than an exceedingly small fraction of the total number of molecules subjected to the rays; even in the most favourable cases the proportion does not exceed one in 10^{12} .

The degree of ionization produced by a given beam of X-rays depends on the nature of the gas and on its pressure. If the conditions are such that no homogeneous radiation is excited in the gas, the ionization is directly proportional to the pressure of the gas down to the lowest pressures at which measurements have been made. The relative amount of ionization produced in various gases at the same pressure depends upon the nature of the gas, and also to a smaller degree on the quality of the rays. In general it increases with the atomic weight of the gas. It is exceptionally small in hydrogen, the number of ions per unit volume for a given intensity of radiation being less than one per cent. of that in air at the same temperature and pressure while the ionization in mercury methyl is no less than 425 times that in air under the same conditions.

Providing the density of the gas is kept constant the ionization produced in a gas under given conditions is independent of the temperature over a range of temperatures from -180° C. to $+180^{\circ}$ C.

In all experiments on ionization of gases by X-rays it is most important to avoid exciting the corpuscular radiation from the electrodes or the walls of the ionization chamber, as the

ionization produced by these rays is sufficiently large to mask almost completely the ionization produced by the direct action of the beam on the gas. The form of ionization chamber shown in Fig. 5 is convenient. The incident rays must be carefully limited by lead diaphragms so as not to strike the electrodes which are made of aluminium, in order to reduce as much as possible the effects which may be produced by the scattered radiation from the gas falling on them. The window admitting the rays and the far end of the chamber should be sufficiently far from the electrodes to ensure the complete absorption of the corpuscular radiation from them in the gas before reaching the neighbourhood of the electrodes. The electrode connected to the electroscope may be surrounded if desired by a wide guard ring, so that the electric field across the gas is straight and uniform.

X-rays ionize the gas, not directly but by means of the corpuscular radiation excited in the gas by the passage of the rays. These electrons as we have seen are emitted with a high velocity, and in passing through the gas produce ionization by collision with the molecules of it. Various indirect evidence of this has been accumulated. It is, however, proved directly by the photographs of the passage of a beam of X-rays through a gas taken by C. T. R. Wilson's expansion method (Fig. 18). The tracks of the electrons emitted by the rays are shown up clearly by the condensation of the water drops on the ions produced by them. The track of the beam of primary X-rays shows no such ions. It is only evident as the line from which the corpuscular tracks begin. Hence the X-rays produce no ions directly, but only through the medium of the secondary electrons ejected by them from the atoms of the gas. It is also clear from the photograph (Fig. 18), which is taken in a gas at ordinary pressure, that only an exceedingly minute proportion of the atoms through which the rays pass eject an electron. This fact has found no explanation on the ordinary continuous wave front theory of radiation.

CHAPTER XI

THE α -RAYS

96. **Properties and nature of the α -rays.** The α -rays from radio-active substances are distinguishable from the other radiations by their absorbability, being completely stopped by less than 10 cm. of air or 1/10 mm. of aluminium. They can be detected by their action on a photographic plate, which is, however, very weak, by the ionization they produce in the gases through which they pass which is very intense, or by the fluorescence they produce on a fluorescent screen, the latter method being extremely convenient especially when the radiation is weak. On observing the fluorescence through a low power microscope it is found to consist of a succession of scintillations produced by the successive impact of the individual particles in the rays. It has been shewn that each particle produces a separate flash on the screen when it collides with it. The impact of a single α -particle can thus be observed.

With sensitive apparatus the ionization produced by a single α -particle can also be detected, especially if the effect is multiplied by causing the ions originally produced to make fresh ions by collision. On account of the ease with which a single particle can be observed much more is known about the properties of the α -particles than about those of the β -rays.

By passing a beam of the rays down a long exhausted tube and applying electric and magnetic fields it can be shewn that the α -rays consist of particles carrying a positive charge. The velocity of the particles and the value of the ratio e/m can be deduced from the deflections in the usual ways. The value of e/m is the same for all the α -particles no matter what their source and is equal to 4823. The velocity depends on the radio-active substance from which they are ejected but is a constant for all the particles coming from the same sub-

stance. These velocities range from 1.45×10^9 to 2.2×10^9 cm. per sec.

97. Nature of the α -particle. The ratio of charge to mass for a hydrogen atom when carrying a single electronic charge is 9647 e.m.u. per gm. The value for an α -particle is 4823 or half that of the hydrogen atom. If the charges were the same the particle would thus be twice the mass of the hydrogen atom, and hence probably a hydrogen molecule. It will be shewn later that the particle carries double the charge carried by an electron; its real mass is therefore four times that of a hydrogen atom, and thus corresponds very closely with the helium atom (atomic weight 3.96).

The proof of the identity of the particles with helium has been rendered complete by an experiment due to Rutherford. A very thin walled glass tube *A* (Fig. 72) was sealed into an outer tube *B* which was highly exhausted and connected to a small discharge tube *C*. To prove that there was no connection between *A* and *B* the former was filled with helium under pressure and left for some hours. No trace of the helium spectrum was obtained in the discharge tube *C*. The helium was carefully removed and radium emanation was passed into *A*, and allowed to stand. The glass walls of *A* were sufficiently thin to allow the α -particles from the emanation to pass into *B* where they were stopped by the outer walls. Under these circumstances the helium spectrum became visible in *C* in a few hours, and became brighter as the experiment was continued. As the α -rays were the only particles entering *B* during the experiment it is clear that the α -particles must be atoms of helium.

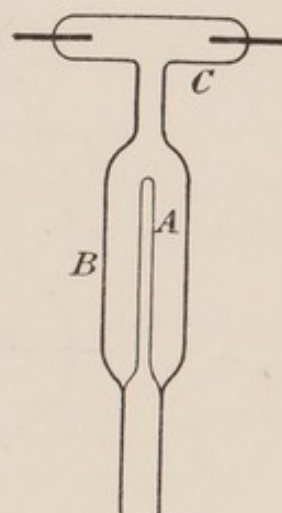

Fig. 72

98. Determination of the charge on an α -particle. Let N be the number of α -particles given out per second by a point source of rays. The number falling on a surface subtending a solid angle Ω at the source will be $\frac{\Omega}{4\pi} N$, assuming that the

particles are given off equally in all directions. If E is the charge on each particle the total charge reaching the area per second will be $\frac{\Omega}{4\pi} EN$. Thus if we can determine this charge and the value of N we can deduce E .

The experiments were first performed by Regener. The number of α -particles striking a given area per second was determined by counting the scintillations they produced on a fluorescent screen of brown diamond, of known area placed at a known distance from the radio-active material. The charge carried by the rays was found by allowing them to enter a

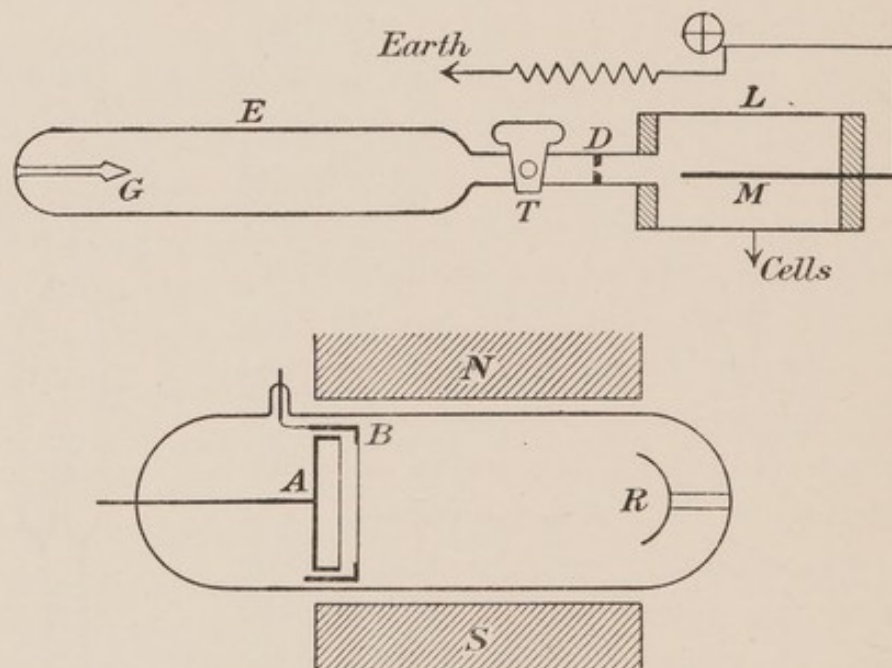

Fig. 73

Faraday cylinder. In this way Regener obtained a value for the charge on an α -particle of 9.58×10^{-10} e.s.u.

Owing to the uncertainty which existed at the time as to whether every α -particle produced a scintillation on striking a fluorescent screen, the experiments were repeated by Rutherford, using an ionization method. Rutherford's apparatus is shewn in Fig. 73.

The detector consisted of a cylindrical ionization chamber L with a central wire electrode M , the rays entering the chamber through a stop D of known aperture. The central wire was connected to an electrometer, while the outer case was connected

to a battery of cells. The pressure in L was reduced until the field applied was sufficient to produce a considerable degree of ionization by collision in the remaining gas. Thus when a supply of ions was created in the gas by the entrance of an α -particle the effect was multiplied by collision and a considerable charge reached the electrometer, the needle of which gave a considerable deflection. Thus the entrance of a single particle was signalized by a kick in the electrometer needle. As it was not desirable to let these charges accumulate, the electrometer quadrant was placed to earth through a very high resistance, so that the charges leaked away to earth.

The source of rays was radium C (§ 127) which was concentrated on a metal cone G . The distance GD being known (about 150 cm.) the solid angle subtended by the aperture at the source G could be calculated. From the number of particles actually entering the chamber through the aperture the whole number emitted per second could be calculated. When desired the particles could be prevented from entering L by turning the tap T as shewn in the diagram so as to close the passage. It was found that the number of particles emitted per gm. of radium C per second was 3.4×10^{10} .

The charge emitted per second by the same product was measured by allowing the rays to fall on a thick plate A connected to a sensitive electrometer. The radium C was deposited at the bottom of a shallow cup R , and the area of the aperture B and its distance from R were accurately known. In order to avoid any loss of charge from A by ionization currents the apparatus was exhausted to a very high vacuum. When α -rays impinge on matter they give rise to a considerable emission of very slowly moving negative corpuscles often known as δ -rays. If these were allowed to leave the disc A , or to reach it from other parts of the apparatus struck by the rays, a considerable error would arise. To prevent this the whole apparatus was placed between the poles of a strong electromagnet NS , which by curling the paths of the δ -rays into very small circles prevents them from leaving their point of origin. Very thin aluminium leaf placed across the opening B and across the entrance to A serves a similar purpose.

In this way it was calculated that one gram of radium C would give out 31.6 electrostatic units of positive charge per second.

The number of carriers was, as we have seen, 3.4×10^{10} per second, and thus the charge on each α -particle is 9.3×10^{-10} e.s.u. Regener obtained a value 9.58×10^{-10} e.s.u. using a polonium disc. It will be seen that the mean of these numbers is almost exactly twice the value 4.7×10^{-10} which we have seen represents the best value for the charge on an electron. Thus the charge on an α -particle is twice the charge on an electron, and the α -particle is an atom of helium which has lost two electrons. The close agreement of the numbers obtained in this way with those previously obtained by experiments on negative electrons is a further proof of the atomic nature of electricity. Their mutual agreement proves the truth of the assumption made by Regener that each α -particle produces a separate scintillation on a suitable fluorescent screen.

99. Passage of the α -rays through matter. It has been noted that the α -rays are completely stopped in a very small thickness of matter. If a layer of radio-active material is deposited on a plate and successive thin sheets of, say, aluminium leaf are placed over the layer the activity of the rays passing through is gradually reduced. The method, however, is not a good one. The α -rays are emitted in all directions and the path of the oblique rays in the absorbing sheet will be much greater than that of the rays which are projected normally to the surface. The effects are, therefore, complex, and in order to study the subject in detail it is necessary to work with pencils of the rays of small angle so that the paths of the different particles are approximately parallel to each other. This can most easily be effected by taking a point source of radiation and limiting the rays by means of a small aperture in a lead plate at some little distance from the source.

If such a pencil is allowed to fall on a fluorescent screen the number of particles falling on the screen can be measured by counting the scintillations. If now very thin sheets of some absorbing substance are interposed between the aperture and

the screen, it is found that the number of scintillations made per second on the screen remains constant until the thickness of absorbing material reaches a certain critical value (depending on the nature of the absorbing substance and the velocity of the rays) at which the scintillations suddenly cease entirely. There is thus for each substance a definite thickness which the rays can penetrate; all the particles making up the rays penetrating to exactly the same distance. This critical distance is called the *range of the particles* in the substance.

The range depends only on the velocity of the particles and the nature of the absorbing substance. It is of course necessary in these experiments to work with a very thin layer of radioactive substance. All the particles are initially projected from the same radio-active substance with the same velocity. If, however, the emitting layer is thick the particles from the deeper portions of it will have completed part of their course before reaching the surface, and their range in the air or other absorbing medium above will be correspondingly reduced.

As the absorption in solids is very large, the range is generally measured in air at atmospheric pressure. Under these circumstances the range of the α -particles from radium C is 7.0 cm., and those from radium itself 3.5 cm. The range in a given substance depends only on the mass of matter traversed by the rays. In a gas it is thus inversely proportional to the pressure. This fact is made the basis of a very simple method of finding the range of an α -particle. The radio-active matter is placed at the centre of a spherical flask, the walls of which are coated inside with willemite or other phosphorescent substance. The flask is then gradually exhausted until the α -particles can just reach the walls of the flask and scintillations begin to appear. The range at atmospheric pressure is then the radius of the sphere multiplied by the ratio of the atmospheric pressure to the actual pressure in the flask.

The absorption of the α -rays is thus not due to a gradual diminution of their number, as this number remains constant until the rays completely disappear. It must consequently be due to a gradual absorption of their energy. The matter has been tested directly by measuring the velocity of the particles

after passing through various absorbing sheets of matter. The experiments are made particularly easy by the use of the fluorescent screen. The rays from a wire R excited by exposure to radium emanation pass down a long exhausted glass tube T (Fig. 74) and are formed into a narrow pencil by the lead diaphragm D . This beam then continues between the poles of an electromagnet NS , and falls on a screen F . From the geometry of the apparatus and a measurement of the shift produced in the fluorescent spot when the magnetic field is turned on the radius of curvature of the rays in the magnetic field can be calculated, and using the equation $\rho = vm/He$ (37) v can be calculated since the ratio of e/m for the rays is known. It was found that the velocity of the rays after passing through a distance x of air could be expressed in the form

$$v^3 = a(R - x) \dots \dots \dots (94)$$

where R is the range of the particle in air. The cube of the

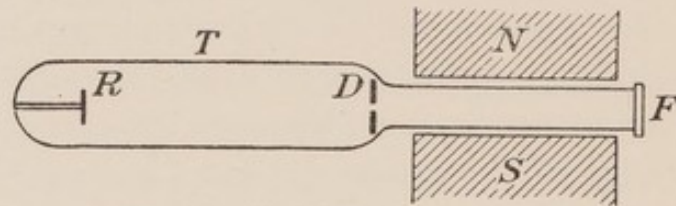

Fig. 74

velocity is thus directly proportional to the distance the ray has still to run. The absorption is thus an absorption of the energy of the particles during their passage through matter.

A portion of any rate of this energy absorbed is used in ionizing the gas. It is a probable assumption that the ionization produced by an α -ray in a given thickness of matter is proportional to the energy absorbed. On this assumption the intensity of the ionization I will be proportional to $\frac{d}{dx}(\frac{1}{2}mv^2)$ or since the mass is constant

$$\begin{aligned} I &\propto \frac{d(v^2)}{dx} \propto \frac{d}{dx}(R - x)^{\frac{2}{3}} \\ &\propto (R - x)^{-\frac{1}{3}}, \\ \therefore I^3 &= a'/(R - x) \dots \dots \dots (95) \end{aligned}$$

where a' is a constant.

According to this expression the ionization produced by an α -particle should increase as the velocity decreased, rising to a very sharp maximum as the particle reaches the end of its range and then immediately dropping to zero when the particle comes to rest.

It will be noticed that combining the two equations we have

$$Iv = \text{constant.} \quad (96)$$

The amount of ionization produced in an atom by an α -particle is thus proportional to the time which the particle takes to pass across an atom, a very interesting result.

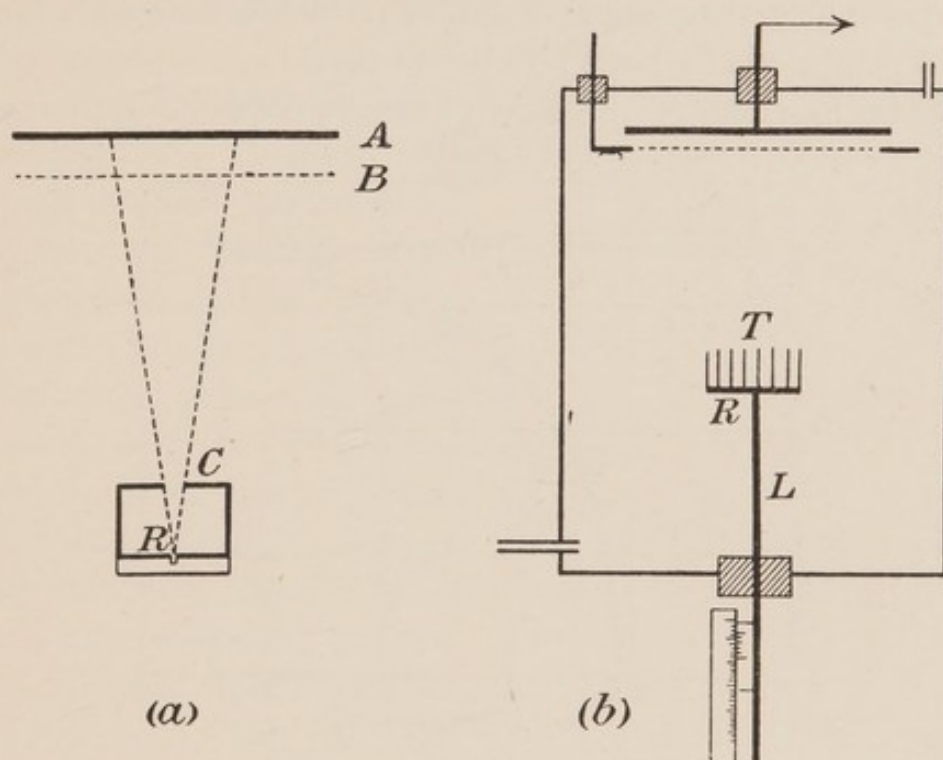

Fig. 75

100. Bragg's experiments on the range of the α -particles. The measurement of the ionization produced by α -rays at various points along their path was investigated by W. H. Bragg, whose experiments (which were considerably earlier than those we have just described) were the first to throw light on the absorption of the rays. His apparatus is shewn very diagrammatically in Fig. 75 *a* and in rather more detail in Fig. 75 *b*. The α -rays originate in a very thin film of radio-active substance at *R* and are limited to a fine pencil by the lead stop *C*. The

ionization chamber consists of two plates *A* and *B* very close together, the lower one being made of gauze to allow the entrance of the rays. The saturation current between the electrodes is proportional to the mean intensity of ionization between *A* and *B*. By altering the distance between the ionization chamber and *R* the ionization produced by the particles at various points on their path can be measured.

The ionization produced in such a narrow chamber by such a small pencil is very small. The effect is increased therefore by forming what is practically a series of such arrangements side by side. The radio-active substance is deposited in a very thin layer over the plate *R* (Fig. 75*b*), which is then covered with a grid *T* formed of a large number of metal tubes placed side by side. It is found more convenient to move the radio-active matter

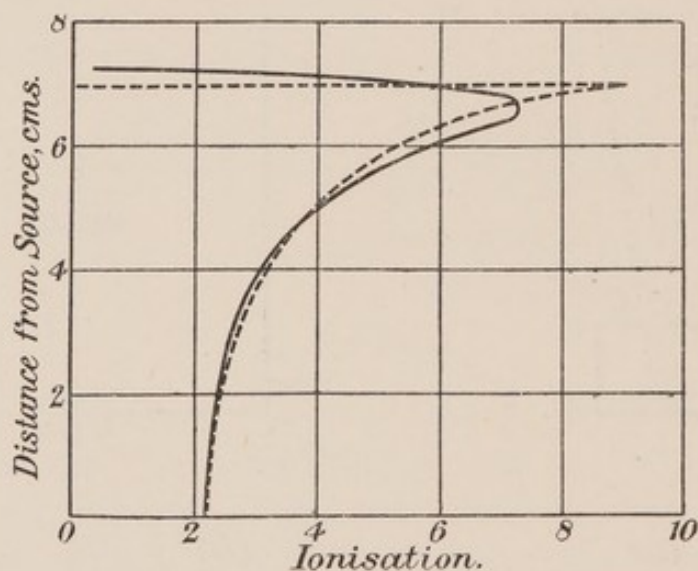

Fig. 76

rather than the ionization chamber, so that *R* is carried by a rod *L* which can be raised or lowered by a micrometer screw. The distance of *R* from the ionization chamber can thus be accurately measured. In order that different gases and different pressures could be employed the apparatus was enclosed in an air tight case.

Using a single radio-active substance, such as radium C, Bragg obtained a curve similar to that in Fig. 76. The ionization produced increases with the distance from the source up to a maximum and then drops with great rapidity to zero.

The agreement with the theoretical curve shewn by the dotted lines in the same diagram is thus sufficiently close. The fact that the cessation of ionization is not quite abrupt is due to two causes. In the first place the beam used is not accurately parallel, so that the normal rays penetrate to a somewhat greater distance from the source than those which are more oblique before traversing the same actual distance in the gas. In the second place some of the rays are deviated by collision with the particles of air and hence even if the beam were originally parallel some of the particles would become oblique before reaching the end of their path and would thus not travel the full vertical distance from the source. We shall return to this later.

The ionization per cm. of path depends only on the speed of the α -particle. Thus, if the curve is drawn for the α -particles from radium itself, the rays from which have only half the range of those from radium C, it will be found to be the same as that for radium C but with each ordinate decreased by a constant amount equal to the difference between the ranges of the two sets of particles. The relation between the curves for the two sets of rays is represented by the two curves in Fig. 77.

In his earliest experiments Bragg used a thin layer of ordinary radium and obtained a complex curve shewn by the thick line in Fig. 78. We are now in a position to consider this curve.

It has been shewn that a sample of radium which has been standing for some time is really a mixture of several radio-active substances, namely radium itself, its emanation, and radium A, B and C (Chap. XIV). Of the five substances present, radium B emits only β - and γ -rays. We are

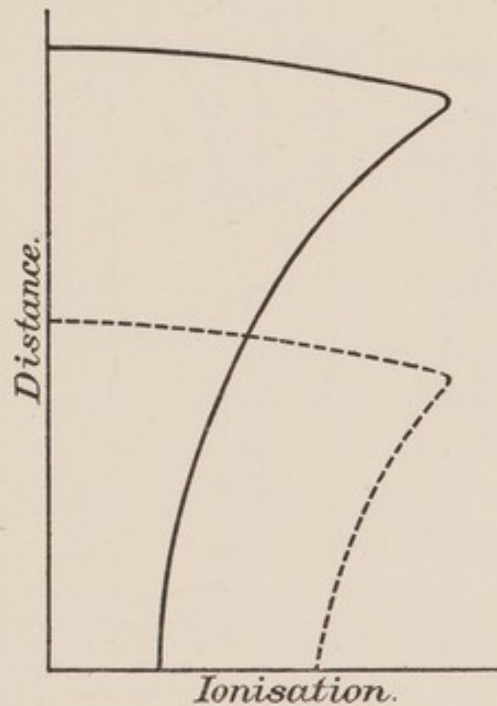

Fig. 77

thus left with four α -ray producing substances, and four sets of α -rays. Their ranges in air at normal pressure are 3.50, 4.23, 4.83, and 7.06 cm. respectively.

Let us commence by drawing the curve for the α -particles from radium C, which have the longest range. It is represented by the line *Oabc* on Fig. 78. The *abscissa* of this curve represents the total ionization at the distance of the corresponding *ordinate* due to the rays from radium C. Now by Rutherford's theory of radio-active equilibrium (§ 118) the number of atoms of each product which are transformed in each second must be the same for each product, since for

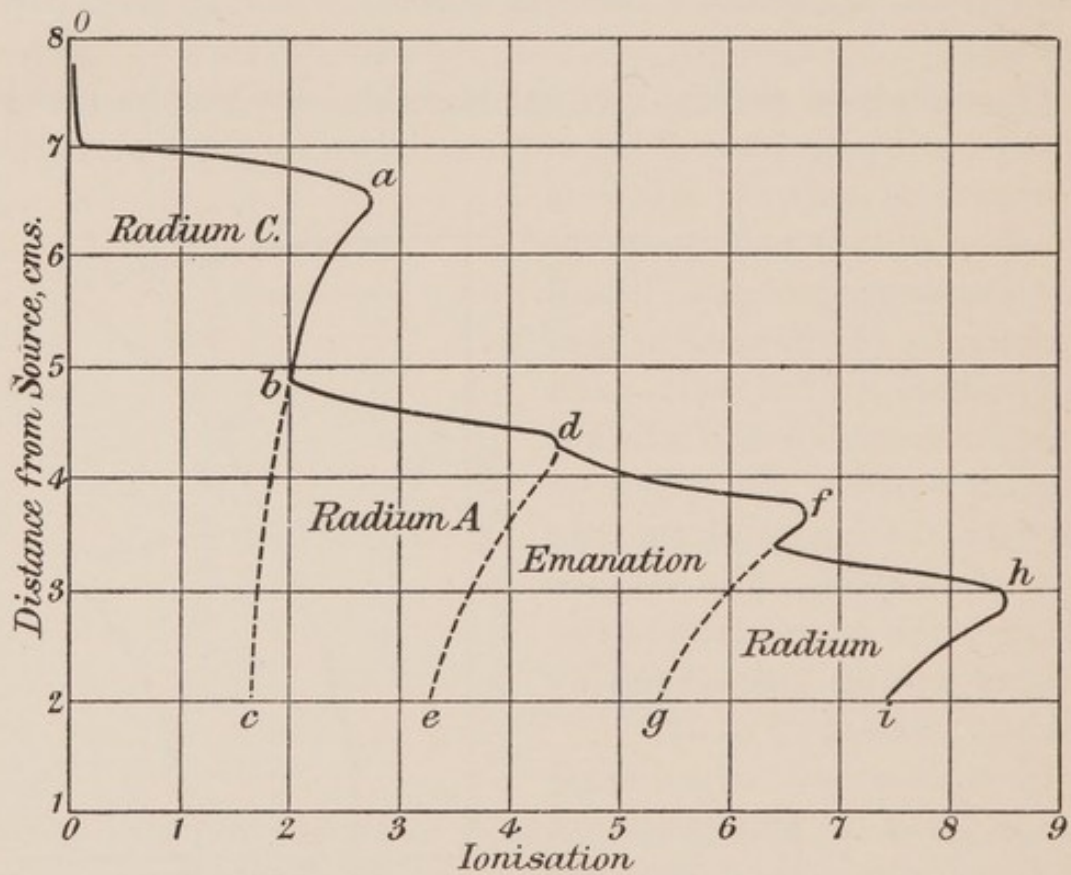

Fig. 78

equilibrium the quantity of radium emanation, say, which is changed into radium A must equal the amount of emanation formed from the radium in the same time, and hence the amount of radium decomposed. Hence if each atom is disintegrated with the emission of one α -particle, the number of α -particles from each of the products must be the same. To obtain the curve for radium A we have to lower each of the ordinates

of the radium C curve by 2.23 cm. the difference in range between the two sets of particles. The sum of the abscissae of these two curves will give the ionization due to the α -particles from the radium C and radium A, in the substance. In an exactly similar way we can obtain the curves for the emanation and radium itself since all the ranges are known. The sum of these abscissae at any point will give the total ionization to be expected at a distance from the source given by the corresponding ordinate. In this way we can build up the full curve *Oabdfhi* (Fig. 78). The curve so obtained is found to agree exactly with the experimental curves obtained by Bragg for radium in radio-active equilibrium with its products.

This agreement affords an excellent proof of the two assumptions we have made (*a*) that allowing for the difference in velocity of projection the ionization curves are the same for radium and each of its products, (*b*) that with radium in radio-active equilibrium, the number of α -particles projected per second from each product is the same. This affords very strong confirmatory evidence of the truth of Rutherford's theory of radio-active change which is described more fully in a subsequent chapter (Chap. XIII).

101. The stopping power of an atom for α -particles. If the source of α -rays is covered with a thin sheet of metal, the effect is to reduce the velocity of the particles and thus to reduce each ordinate of the distance-ionization curve (Fig. 76) by a definite amount. By measuring the distance through which the maximum of the curve is lowered, that is, the reduction of the range of the particle, we can calculate the quantity of air at normal pressure and temperature to which the given sheet is equivalent. In a compound curve such as that of Fig. 78 each ordinate is reduced by exactly the same amount. Experiments on these lines using leaf of different materials enable us to find the equivalent thickness of air for various substances. It is obvious that for a given substance it is the mass and not the thickness of it on which the reduction in velocity depends.

The ratio of the mass of a column of air of unit cross-section

to the mass per unit area of the substance which produces the same diminution in the speed of the α -particle is called the *stopping power* of the substance.

It was found better to express the stopping power in terms of the number of atoms traversed rather than in terms of the mass. The transformation can easily be made. Thus the stopping power of silver is 0.415; that is to say, in passing through a given mass of silver the velocity of the α -particle is only reduced by 0.415 of the decrease produced in passing through an equal mass of air. But for equal masses of air and silver the former contains $108/14.4$ times the number of atoms, hence atom for atom silver stops $0.415 \times \frac{108}{14.4} = 3.1$ times as much as air. This is called *the stopping power of the atom*. Experiment has shewn that except in the case of very light elements *the stopping power per atom is proportional to the square root of the atomic weight*, the mean value of the stopping power over the root of the atomic weight being about 0.3.

The stopping power of an atom is independent of its state of chemical combination, being the same in compounds as in the free state. Thus the stopping power of a compound can be calculated from that of its constituents.

102. The scattering of the α -particles. We have so far tacitly assumed that the α -particles travel in straight lines through the gas, and the agreement observed between theory and experiment shews that this assumption is true in the main. There is, however, always the possibility that a collision between an α -particle and an air molecule may produce a deflection of the former. In this case although the actual length of path of the particle might remain the same it would not penetrate so far from the point of origin. Thus taking a bundle of rays, the ionization between the plates would fall off somewhat less abruptly than would be the case if the particles suffered no deflection. This is illustrated in Fig. 79, where e , f and g are supposed to represent the actual paths of three α -particles of equal range, two of which suffer deviation from their course before reaching the ionization chamber AB . Such a deviation

is to be seen in the case of one of the actual tracks of α -particles shewn in Fig. 16.

The scattering of the α -rays has been investigated by Geiger using the fluorescent screen method, which is specially convenient for experiments of this kind as it enables us to detect individual particles. He found that in many cases the individual particles suffered appreciable deflections from their initial directions, before reaching the end of their course. The deflections were, as might be expected, distributed according to the probability law. In passing through a thickness of gold leaf equivalent in stopping power to 3.68 cm. of air the average deflection was as much as 7° . The most probable

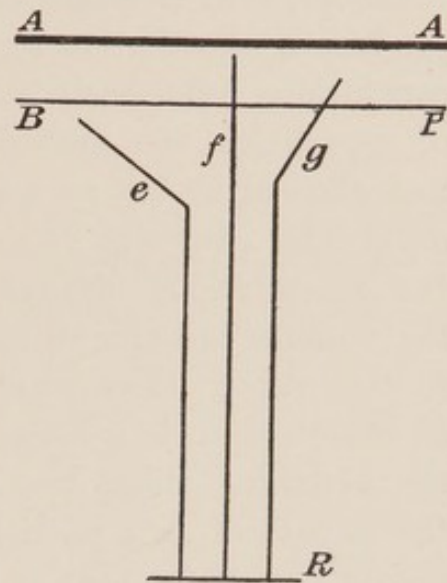

Fig. 79

angle was roughly proportional to the thickness of material through which the rays had passed.

Occasional particles were, of course, in accordance with the law of probability deflected through much larger angles. Using a gold plate it was found that one particle in about 8000 suffered a deflection greater than 180° and so emerged on the side on which it had entered. These results sufficiently explain the want of abruptness in the ending of the curve of Fig. 76.

For different absorbing substances the amount of the scattering increases with the atomic weight being roughly proportional to it.

As might be expected the deviations are most violent where the velocity is smallest, that is, near the end of the path.

Having lost its velocity the α -particle is no longer able either to ionize or to produce scintillations on a screen. It is also unable to retain its charge, and thus becomes simply an atom of helium subject to the ordinary laws governing a gaseous particle.

So far we have been considering only the effect of the collision on the α -particle itself. It is obvious, however, from the ordinary laws of impact, that if the atom with which it collides is free to move, if for example the α -particles are passing

through a gas, the atom itself will be projected as the result of the impact, with a velocity which may be comparable with that of the α -particle itself, or, if the atom is lighter than the α -particle, may even exceed that velocity. We should expect therefore, that it would be able, under these circumstances, to produce a scintillation on striking a fluorescent screen. These conclusions have been verified by Marsden. A narrow pencil of α -particles was passed down a tube containing hydrogen and allowed to fall on a fluorescent screen. The range of the α -particles used was 24 cm. in hydrogen, and the majority of the scintillations disappeared abruptly when the length of the column through which the rays had to pass was increased to this value. Occasional scintillations however continued to be observed up to a distance of 82 cm.; that is to say, some of the hydrogen atoms had acquired a velocity, as the result of the impact of an α -particle, sufficient to give them a range of nearly four times that of the α -particles themselves. Allowing for the fact that a hydrogen atom has only one-quarter the mass of a helium atom it can be shewn that the maximum velocity of these long range hydrogen atoms is approximately 1.6 times that of the α -particles themselves. This result has important bearings on the theory of atomic structure.

The impact between the α -particle and the atom is so great that the latter is apparently occasionally broken up by the force of the blow. Thus Rutherford, by passing the rapidly moving α -particles from radium C through pure nitrogen, has recently obtained long range particles the properties of which seem to identify them with hydrogen. This disintegration of a nitrogen atom is of great interest.

CHAPTER XII

THE β - AND γ -RADIATIONS

103. **Nature of the β -rays.** The β -rays can be distinguished from the α -rays by their greater penetrating power, as they are able to produce measurable effects after passing through absorbing sheets of 100 times the thickness required to stop the α -particles. Their nature was first investigated by Becquerel who shewed that they consisted of charged particles by the following simple experiment. A small quantity of uranium oxide was placed in a small lead dish on the back of a photographic plate, the film side being downward. The whole was then placed between the poles of an electromagnet in a dark room. After some hours the plate was developed, and was found to be blackened immediately below the lead dish, the paths of the rays having been bent into circles by the action of the field.

A modification of the same experiment (Fig. 80) shewed that the rays were heterogeneous.

The plate was placed film side upwards between the poles of the magnet and exposed to the rays for some time. On developing the plate a diffuse

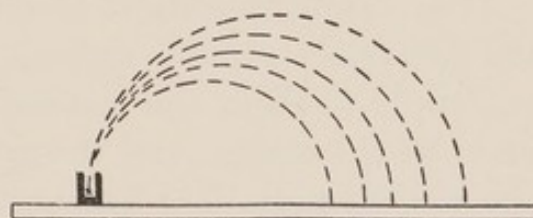

Fig. 80

patch was found shewing that some of the rays had been bent into smaller circles than others. By placing different thicknesses of aluminium foil on the plate it was found that the part of the patch nearest the source disappeared sooner than that further away. The more deviable rays were thus more absorbable than the others. Since

$$\rho = mv/He$$

these rays are the slower ones, assuming that the ratio of e/m is constant.

The similarity of the β -rays to cathode rays was further

established by Curie, who shewed that they carried a negative charge. In performing this experiment it is necessary to avoid the presence of air, as the latter becomes conducting under the action of the rays and the charge is thus unable to accumulate. In recent experiments this difficulty is overcome by working in a high vacuum. Curie however surrounded his plate by a solid dielectric instead. His apparatus is shown in Fig. 81.

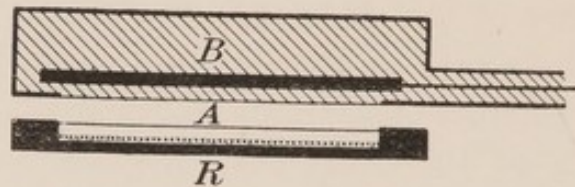

Fig. 81

The β -rays from the radio-active material in *R* penetrate the thin aluminium leaf *A* and the thin layer of wax, but are stopped by the lead plate *B*, giving up their charge to it. On performing the experiment it was found that the electrometer connected to *B* shewed a gradual but steadily increasing deflection when the source of radio-active substance was placed below *A*. The sign of the charge was negative.

104. Determination of e/m and v for the β -rays. Since the β -rays are rapidly moving negatively charged particles we can apply to them the methods of measuring the ratio of the mass to the charge, and the velocity, which were employed for the cathode rays. The first accurate experiments were made by Kaufmann; they have been repeated by numerous observers.

The method adopted was the one where the electric and magnetic fields are parallel, and the two deflections thus at right angles to each other, the theory of which has already been considered (§ 53) in connection with the positive rays. The apparatus used is shewn in Fig. 82 (*a*).

The source of the rays was a small speck of radium compound placed at *R*, while the rays were limited to a narrow pencil by a slit *A* in a thick lead plate. Before reaching the hole *A* the rays passed between two metal plates, which could be adjusted by levelling screws to be perfectly parallel. The plates could

be raised to different potentials by means of wires which were fused through the walls of the containing glass vessel. The photographic plate P was mounted at the top of the chamber, and the whole was carefully exhausted to a very high vacuum. The whole vessel was placed between the poles of a strong electromagnet N, S .

On developing the plate a trace of the rays was a single continuous curved line (Fig. 82 (b)). If the rays had differed only in velocity this line would have been straight (see (49), p. 102). It was, however, found to be curved, shewing that the value of e/m was not constant but varied with the velocity. The fact that the line was single and unbroken shewed that this important

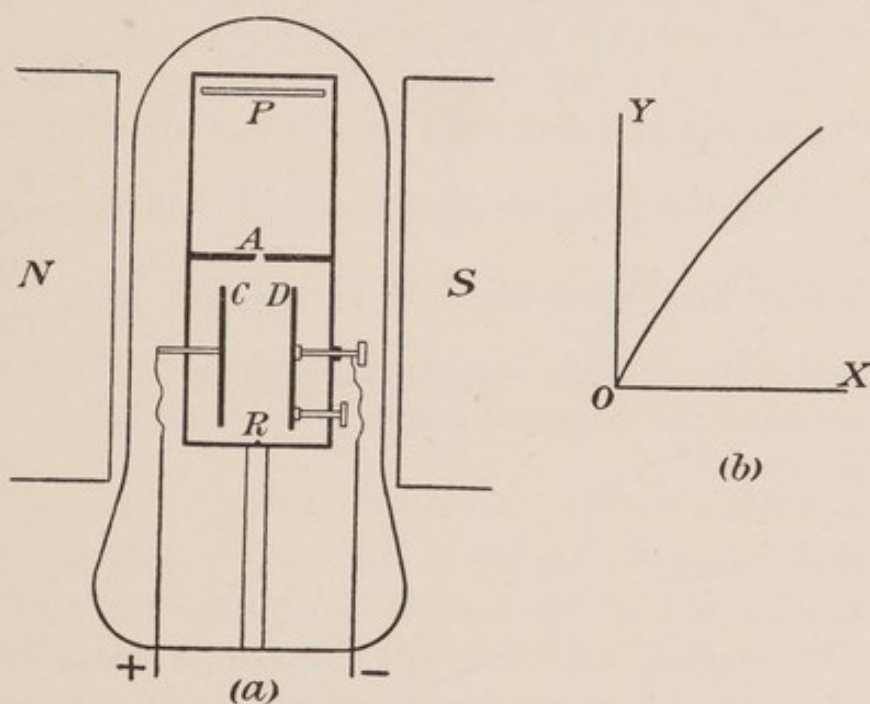

Fig. 82

ratio was a continuous function of the velocity of the rays. In other words for every value of the velocity there was a corresponding value for the ratio e/m which depended on the velocity alone.

The calculations necessary to evaluate the results are hardly so simple as those for Sir J. J. Thomson's experiments on the positive particles. Allowance has to be made for the fact that the two fields are not coterminous. Very careful experiments and elaborate calculations were made to determine the end-corrections for the two fields.

Since the curve shewed no signs of breaks it was very improbable that the rays consisted of sets of different particles. It is equally improbable that the charge was gradually changing, since the great accumulation of evidence has shewn that the charge e is atomic. We are thus led to the conclusion that the mass of a β -particle is a function of the velocity with which it is moving.

105. Electromagnetic mass. It can easily be shewn that a moving charge will act as if it possessed mass from the mere fact that it carries a charge. Consider a point charge moving with a velocity v . This will be equivalent to a current element coinciding with the path of the particle and equal to ev , where e is the charge and v the velocity. The magnetic field due to the moving charge at a distance r from it in a direction making an angle θ with the direction of motion will thus be $\frac{ev \sin \theta}{r^2}$.

The energy in a magnetic field of strength H is $\frac{\mu H^2}{8\pi}$ per unit volume. Hence if du is a small element of volume at the point considered the magnetic energy in that element of volume will be $\frac{\mu}{8\pi} \left(\frac{ev \sin \theta}{r^2} \right)^2 du$.

The whole magnetic energy in the space round the particle will be the integral of this from the surface of the particle to infinity. To evaluate this, with the electron as centre describe two spheres of radii r and $r + dr$ and draw two radii making angles θ and $\theta + d\theta$ with the direction of motion. If these are supposed to rotate about the direction of motion of the electron they will cut out from the spherical shell an annulus the volume of which is

$$2\pi r \sin \theta \cdot r d\theta \cdot dr.$$

But the magnetic field is obviously constant throughout the space so obtained and hence the energy in the annulus is

$$\frac{\mu}{8\pi} \left(\frac{e^2 v^2 \sin^2 \theta}{r^4} \right) 2\pi r^2 \sin \theta d\theta dr = \frac{\mu e^2 v^2 \sin^3 \theta d\theta dr}{4r^2}.$$

The energy in the spherical shell is thus

$$\begin{aligned} 2 \int_0^{\frac{\pi}{2}} \frac{\mu e^2 v^2 \sin^3 \theta dr}{4r^2} d\theta &= \frac{\mu e^2 v^2 dr}{2r^2} \int_0^{\frac{\pi}{2}} \sin^3 \theta d\theta \\ &= \frac{1}{3} \frac{\mu e^2 v^2}{r^2} dr. \quad \dots \quad (97) \end{aligned}$$

If the charge is carried by a small sphere of radius a the total

$$\begin{aligned} \text{magnetic energy in the space is } \int_a^{\infty} \frac{\mu}{3} \frac{e^2 v^2}{r^2} dr \\ = \frac{\mu}{3} \frac{e^2 v^2}{a}. \quad \dots \quad (98) \end{aligned}$$

This energy must be given to the particle when it is set in motion. If the particle has a mechanical mass of M the work done in giving the particle a velocity v is thus

$$\frac{1}{2} M v^2 + \frac{\mu}{3} \frac{e^2 v^2}{a} = \frac{1}{2} \left(M + \frac{2}{3} \frac{\mu e^2}{a} \right) v^2. \quad \dots \quad (99)$$

The particle thus behaves as if its mass had been increased by $\frac{2}{3} \frac{\mu e^2}{a}$. Thus even if M is zero the particle will have a mass

equal to $\frac{2}{3} \frac{\mu e^2}{a}$ due to its charge e ; this is called its *electromagnetic mass*.

It can be shewn on the electromagnetic theory that the above analysis is only true if the velocity of the particle is small compared with that of light (practically if it is less than one-tenth that of light). If the velocity of the particle approximates to that of light the distribution of the electric field round the moving charge is altered in such a way as to increase the electromagnetic energy of the field, and thus the electromagnetic mass of the particle. The analysis is complicated and starting from different assumptions as to the behaviour of the electron somewhat different formulae have been developed by different physicists. The various formulae differ very little from each other when translated into numbers, and it has been a matter requiring much experimental skill to distinguish between them.

Kaufmann adopted the formula of Abraham who gave

$$\frac{m_v}{m_0} = \frac{3}{4\beta^2} \left(\frac{1 + \beta^2}{2\beta} \log \frac{1 + \beta}{1 - \beta} - 1 \right) \quad \dots \quad (100)$$

where m_v and m_0 are the electromagnetic masses of the charged particle when moving with a velocity v and with an infinitesimally small velocity respectively, and β is the ratio v/c where c is the velocity of light. Kaufmann found that within the limits of experimental error his results could be exactly represented by this formula. But this formula represents only the electromagnetic mass of the particle. If the particle has any mechanical mass M , this will presumably be independent of the velocity, and the total mass of the particle will vary less rapidly than the electromagnetic mass alone. This is not found to be the case. Hence we are led to conclude that the whole mass of the negative particles constituting the β -rays is electromagnetic in nature. Since the value of e/m for the slowly moving β -particles agrees exactly with that for electrons from other sources (Table III, p. 96) the β -particles must be identified with the electron. Hence the mass of any electron is electromagnetic and is due simply to the charge, which it possesses.

The formula (99) can be applied to give us a value for a , the radius of an electron. Since m the mass of an electron is 8.9×10^{-28} gm.

$$8.9 \times 10^{-28} = \frac{2}{3} \frac{\mu e^2}{a}$$

and since μ the magnetic permeability of a vacuum is unity and e is 1.57×10^{-20} e.m.u. the radius of an electron is 1.85×10^{-13} cm. or roughly one ten-thousandth of the radius of an atom. The electron will therefore bear to the atom which contains it approximately the same proportions as those of a pea to a cathedral.

106. Variation of the mass of an electron with velocity. Bucherer's experiments. Owing to the progress of modern theory a much simpler relation between mass and velocity, obtained originally by Lorentz, has now replaced the early formula of Abraham, and is found to give a better agreement with the latest experimental results. Lorentz's formula gives

$$m_v = m_0 (1 - \beta^2)^{-\frac{1}{2}} \quad . \quad . \quad . \quad (101)$$

where β is the ratio of the velocity of the particle to the velocity of light and m_v and m_0 have the same meaning as before.

This formula has been experimentally tested by Bucherer using a very ingenious method. The source of the β -radiation was a small speck of radium fluoride R placed at the centre of two parallel plates A and B (Fig. 83) which were very close together. The plates were maintained at a considerable difference of potential, and the apparatus was placed in a uniform magnetic field at right angles to the plane of the paper. The β -particles from the radium will obviously only be able to escape from between the plates if the electric and magnetic forces upon them are exactly equal and opposite. Otherwise the particles will be deflected by whichever of the two fields is the stronger, and will strike one or other of the plates. The particles are projected at all angles to the magnetic field. Those which emerge from

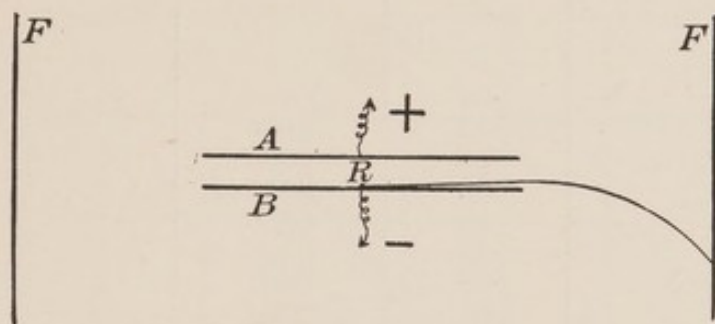

Fig. 83

between the plates at an angle θ with the magnetic field will have a velocity given by

$$Xe = Hev \sin \theta,$$

$$\therefore v = \frac{X}{H \sin \theta}.$$

Thus for any given value of the angle θ the rays which succeed in escaping from between the plates have a definite and calculable velocity.

On emerging from the plates the electrons are acted upon only by the magnetic field, and their deviation is proportional to e/m where m is the mass corresponding to the velocity v . To measure the deviation the rays are allowed to fall upon a photographic film F, F , which is bent into a cylinder coaxial with the plates. The field is reversed during the experiment and the distance between the two traces on the film gives twice the magnetic deviation corresponding to that

direction, from which e/m can be calculated. Hence v and e/m are known for each point on the film.

Bucherer found that the results so obtained agreed very closely indeed with the formula of Lorentz, but less closely with that of Abraham. The values of m_v/m_0 given by the Lorentz formula are contained in Table VII. It will be noticed that the increase in mass is inappreciable until v is at least one-tenth the velocity of light. The discrepancy between the Lorentz formula and the experimental results of Bucherer was less than one per cent.

TABLE VII

β	m_v/m_0
.01	1.000
.10	1.005
.30	1.048
.50	1.115
.60	1.250
.70	1.400
.80	1.667
.90	2.294
.95	3.203
.98	5.025

107. **Passage of the β -rays through matter.** The absorption of the individual β -particles by matter would probably follow a law similar to that for the absorption of the α -particles already considered, that is to say, all particles of the same velocity would be absorbed after traversing some definite length of path in the matter. Unfortunately, owing to the much smaller energy of the particle, it is not yet possible to detect a single β -particle either electrically or by the fluorescent screen. We are thus limited to working with pencils containing large numbers of particles. We saw that the possibility of finding the range of the α -particles from experiments of this kind was due to the fact that the α -particles are but little deflected by matter. With β -rays however, the deflections are very large. Thus absorption experiments corresponding to those of Bragg afford no information as to the range of the

rays, since, owing to the numerous changes in the direction of the path in the matter, the actual path of the particles may be many times greater than the thickness of the absorbing material.

Experiments of this kind have been made by the author. The β -rays were confined to a pencil of small angle by means of lead diaphragms, and the selected pencil of rays was rendered homogeneous (that is, of uniform velocity) by sorting out the complex beam emitted by radium into a "magnetic spectrum" by a transverse magnetic field. It was then allowed to fall normally upon absorbing screens of different materials and the proportion of the radiation transmitted was measured by an ionization method. The curve obtained for aluminium is shewn in Fig. 84, the ordinates giving the ratio I_t/I_0 , where I_t is the

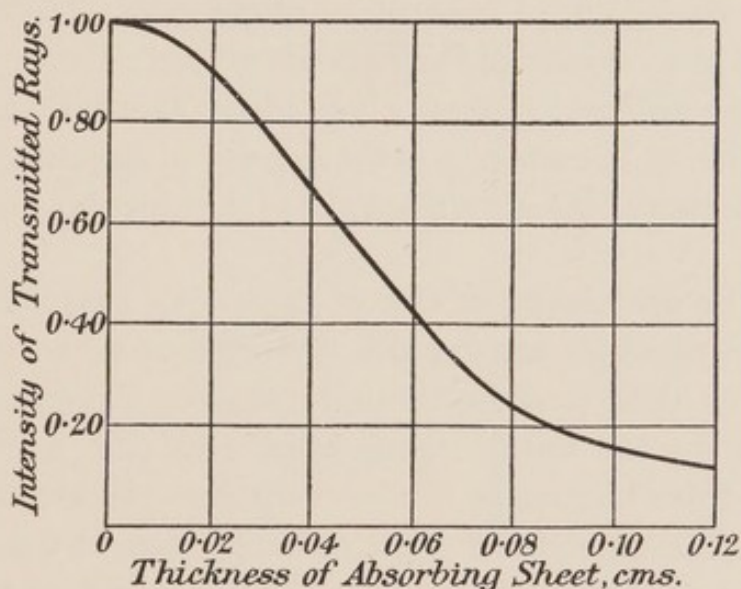

Fig. 84

intensity transmitted through a thickness t of the substance, and I_0 the incident radiation for various thicknesses of absorbing material.

By measuring the velocity of the rays before and after passing through different thicknesses of an absorbing substance W. Wilson shewed that, like the α -particles, the β -rays lose velocity in passing through matter. Owing to experimental difficulties the law of the loss of velocity could not be determined with any accuracy. In the case of the cathode rays however where the experiments are much easier it has been found that

$$V_0^4 - V^4 = kx \quad . \quad . \quad . \quad . \quad (102)$$

where V_0 is the initial velocity, V the velocity after passing through a thickness x of the substance, and k a constant. This law possibly holds also for the β -particles. Owing to the intense scattering, however, it must be noted that the path of the particle in the absorbing screen is probably much greater than the thickness x .

If instead of forming the rays into a definite pencil they are allowed to fall at all angles on an absorbing screen, for example if the screen is placed directly above a layer of the radio-active substance, the absorption of the rays follows an exponential law, the intensity of the transmitted rays being given by the formula

$$I = I_0 e^{-\lambda x} \quad . \quad . \quad . \quad . \quad . \quad (103)$$

λ being the coefficient of absorption of the rays. The coefficient increases as the velocity of the rays is reduced. Using absorbing screens of the different elements it has been shewn by the author that the value of λ/ρ , where ρ is the density of the substance, is a periodic function of the atomic weight of the absorbing substance.

108. The scattering of the β -rays. As has already been noted the β -particles are rapidly deflected from their original course during their passage through matter. The question was investigated by the author using apparatus shewn in Fig. 85. The β -rays from radium at R were bent into the arc of a circle, of constant radius, defined by a series of stops, by a magnetic field at right angles to the plane of the paper. Since the radius of the path of the particles was fixed, for each value of the magnetic field rays of definite velocity given by $\rho H = mv$, where ρ is the radius of the circle and H the field, passed through the apparatus. The rays on emerging from the field fell normally upon an absorbing screen at P . The parallel beam was scattered in the screen and rays emerged at all angles. When circular stops of known radius were placed at S the number of β -particles passing through S into the ionization chamber T was equal to the number which had not been deflected through an angle greater than the angle subtended at P by the radius of the stop. Using stops of different radii the distribution of the particles about their original path could be determined.

Let us suppose that in passing through a single atom the particle is deflected by a small angle θ . The direction of this deflection will be perfectly arbitrary, depending on the exact way in which the particle strikes the atom. The problem is exactly similar to that of the composition of a large number of random displacements, the solution of which has been given by Rayleigh, who shewed that after N encounters the most probable value of the deflection is equal to $\theta\sqrt{N}$. But if n is the number of atoms per unit volume and b the radius of the atom the number of encounters in a thickness t is equal to πnb^2t . Thus the most probable angle of deflection should be

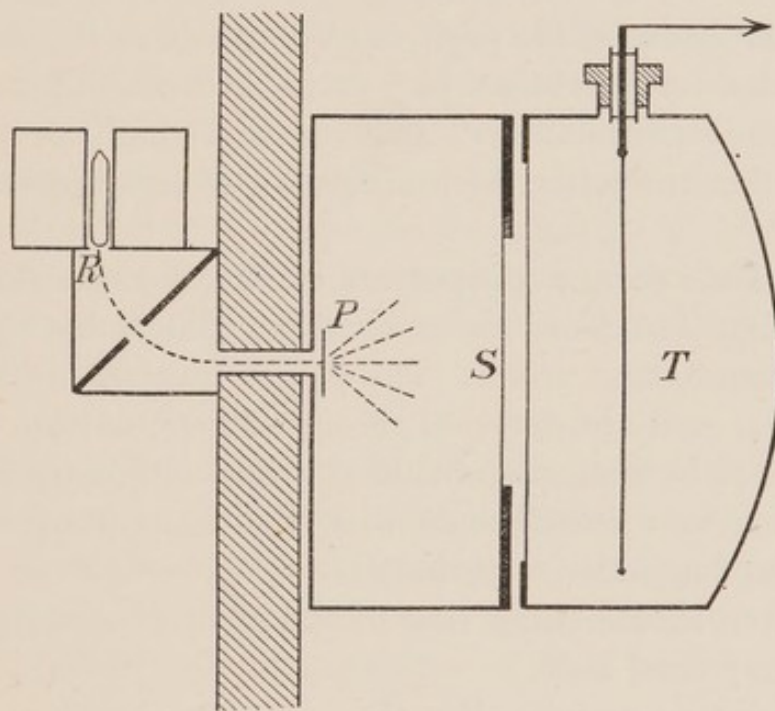

Fig. 85

proportional to the square root of the thickness of the absorbing sheet. This relation was found to be true.

If ϕ is the most probable angle of emergence from a sheet of thickness t , $\frac{\phi}{\sqrt{t}}$ is thus a constant for rays of given velocity and for screens of given material. The ratio increases with the atomic weight of the absorbing substance being roughly proportional to it. For a given angle ψ the thickness of material for which that angle is the most probable angle of emergence is directly proportional to the energy of the incident β -particles.

If we can calculate the deflection produced in a β -particle in its passage through a given atom in terms of the number of electrons present in the atom the results of these experiments can be used to determine the number of electrons present in the atom. Unfortunately different assumptions as to the arrangement of the atom lead to somewhat different estimates. On Sir J. J. Thomson's theory on which the electrons were supposed to be uniformly distributed through a positively charged sphere of atomic radius the number works out at about three times the atomic weight. On Rutherford's theory of the atom the positive electricity is supposed to be confined to a central nucleus of very small dimensions. In this case the deflection will be mainly due to the positive nucleus and on this assumption the number of electrons per atom becomes approximately equal to the atomic number. Evidence is gradually accumulating which makes the latter the more probable assumption.

109. Nature and properties of the γ -rays. The γ -rays are distinguished from the α -rays and β -rays by their much greater penetrating power. The γ -rays from 30 milligrams of radium can easily be detected through 30 cm. of iron. They are not deviated by a magnetic field and therefore carry no charge. Their behaviour corresponds with the assumption that they are electromagnetic disturbances of extremely short wave length, even shorter than that of the most penetrating X-rays from a very hard bulb.

If in sufficient intensity they produce luminosity in a fluorescent screen, and affect a photographic plate. They also produce ionization in gases, and are generally detected by this action.

The relation of the γ -rays to the β -rays is the same as that of X-rays to cathode rays. In all probability the γ -ray is produced by the sudden emission of a β -particle from the radio-active atom. Thus γ -rays are only produced by radio-active substances which are known to emit β -radiation. The actual connection is however somewhat obscure, as there seems to be no proportionality between the intensities of the two phenomena. Thus if the ratio of the γ -radiation to the β -radiation is taken as unity

for radium C, then for thorium D it is about 0.74, for actinium D 0.077, and for uranium X as little as 0.02 or only one-fiftieth of that for radium C.

110. Absorption of γ -rays. The absorption of a beam of γ -rays follows at any rate approximately an exponential law so that if I is the intensity after passing through a thickness of matter equal to d

$$\frac{I_d}{I_0} = e^{-\mu d}. \quad (104)$$

The value of μ depends upon the absorbing substance, and on the source of the rays. The rays from uranium are less penetrating than those from radium, their coefficient of absorption in lead being 0.725 as against 0.50 for the rays from radium. Taking the same source of radiation but different absorbing substances it is found that the value of μ/ρ where ρ is the density is very nearly constant for the majority of the elements. It shews however a marked increase at both ends of the periodic table being exceptionally high both for the very light and the very heavy atoms.

111. Secondary γ -rays. In the same way that a primary beam of X-rays gives rise to scattered X-radiation so a beam of γ -rays gives scattered γ -radiation when it falls on a radiator. The distribution of the secondary radiation round the radiator is very similar to that of the scattered X-rays.

In addition to the scattered γ -radiation, secondary β -rays are liberated when the γ -rays fall on a radiator. This radiation is very much more intense in the direction in which the rays are travelling than in the reverse direction, the eccentricity being generally much more pronounced than in the case of X-rays. The ratio for aluminium is as high as 6 : 1. This result might have been expected from equation (93), since u/v the ratio of the forward to the transverse velocity is proportional to the velocity of the electron ejected, which is in this case a swift moving β -ray having a velocity which may be more than ten times that of the cathode particles ejected by X-rays.

112. Production of γ -rays from β -rays. The reverse effect, that of the direct production of γ -rays by β -rays, has also been demonstrated. The difficulty lies in the fact that the number of β -particles emitted even by a powerfully radio-active substance is quite insignificant in comparison with the number of electrons in the cathode rays of an ordinary X-ray tube. As

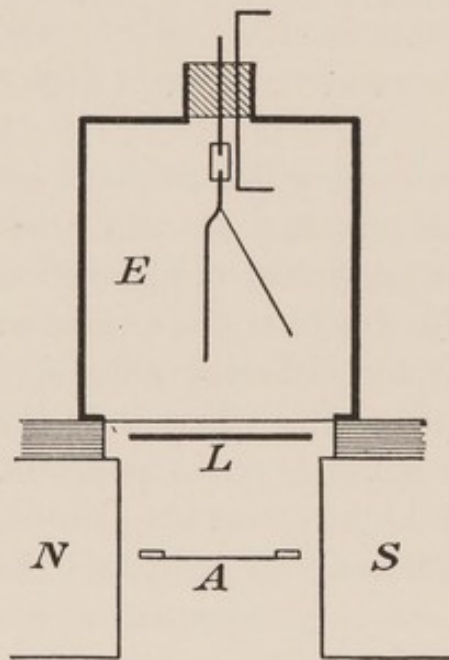

Fig. 86

only a very small fraction of the energy of the β -rays is transformed into γ -radiation, the effect has been somewhat difficult to demonstrate. The method used is indicated in Fig. 86. The measuring apparatus was a simple gold leaf electroscope, *E*. For measurements on the γ -rays an electroscope of this type is generally preferred to the use of an electrometer with a separate ionization chamber. Owing to the great penetrating power of the radiation it would be quite impossible to shield the connecting tubes and the electrometer from

the action of the rays, and thus loss of insulation would result owing to the radiation ionizing the gas in the electrometer and tubes. This would cause a distinct and not readily calculable loss of charge.

The electroscope is usually constructed of lead walls 2 mm. in thickness, so as to cut off all secondary β -radiation from the surrounding air, table, walls, etc. This thickness causes little appreciable diminution in the intensity of the γ -rays themselves.

A source of β -rays (radium E) was chosen which while rich in β -rays was yet poor in γ -radiation. This was spread on a thin sheet of paper at *A*, the paper being used to reduce as much as possible the γ -radiation which might be excited by the β -rays falling upon the support. The substance was placed between the poles *N*, *S* of an electromagnet. The lower face of the electroscope was closed by a thin sheet of aluminium leaf. When the β -rays were deflected away from the electroscope

the current was due solely to the γ -rays from the radium E, and was therefore quite small.

If, however, a lead plate sufficiently thick to absorb all the β -rays was placed at L , immediately below the electroscope, and the field removed so that the β -rays fell upon L , the ionization in E at once increased. This could not be due to the β -rays themselves, as they were unable to penetrate the lead. If, however, the field was again applied so as to prevent the β -rays from reaching L the effect at once ceased. The increased ionization must therefore be due to γ -radiation set up in L by the impact of the β -rays upon it.

The matter has recently been further investigated by Rutherford and his pupils. The γ -rays produced by the impact of the β -rays from a radium compound on a lead radiator were allowed to fall on a lead block, and the velocity of the secondary β -rays produced by them from the block was measured. It was found that just as in the case of the secondary cathode rays produced by the impact of X-rays on a radiator, the velocity of the secondary β -rays produced by the action of the γ -rays on the metal was exactly the same (to an accuracy of within one per cent.) as that of the β -rays used in exciting the γ -radiation.

113. Characteristic γ -radiations. Rutherford has recently shewn that the γ -rays from various radio-active substances contain homogeneous groups of rays. For example the rays from radium C are homogeneous and have a coefficient of absorption λ in aluminium of 0.042ρ where ρ is the density of aluminium. Applying the fifth power law (§ 92) we find that this would be the coefficient of absorption in aluminium of the characteristic K radiation of an element with an atomic weight 214. This is actually the atomic weight assigned to radium C. Hence the γ -radiation from radium C is apparently its characteristic X-radiation excited in it by the action of its own β -rays. Radio-actinium again gives out two sets of γ -rays having values of λ/ρ in aluminium of 9.2 and 0.070. These are found to agree respectively with the absorption coefficients (as calculated by the fifth power law) of the K and L radiations for an element of atomic weight 228, which is that provisionally

assigned to this element. Other homogeneous γ -radiations which have been discovered, such as that from thorium D which gives a value of λ/ρ of 0.035, and which is the most penetrating radiation known, apparently belong to a series of characteristic rays which have not yet been isolated in the X-ray part of the spectrum.

It may further be noted that the less penetrating γ -rays such as those from actinium or radium E will excite the characteristic X-radiation of elements having atomic weights ranging from silver to didymium. The γ -rays are thus merely X-rays of very short wave length corresponding to the characteristic X-radiations of the elements of high atomic weight.

114. Determination of the wave length of γ -rays. The matter has been placed beyond all doubt by the determination recently made by Rutherford of the wave length of the

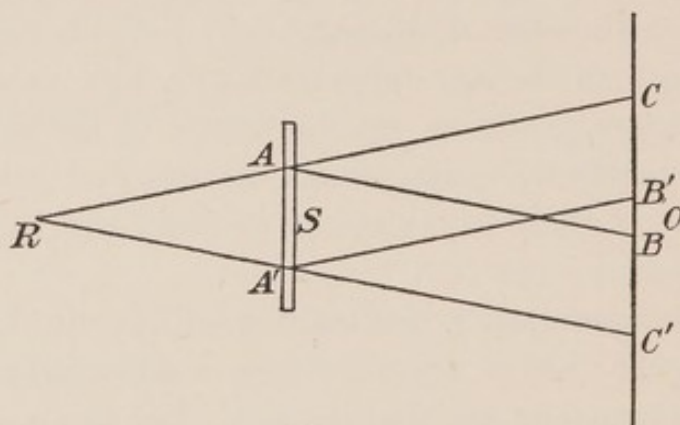

Fig. 87

γ -rays. The method adopted was an interesting modification of that of the X-ray spectrometer already described. As the glancing angle decreases with the wave length it is very small for γ -rays, only about 1 or 2 degrees, and hence could not be measured with any precision. To overcome the difficulty a crystal *S* of rock salt was mounted with cleavage planes parallel to the line *RO* (Fig. 87), the source of γ -radiation being placed at *R* and a photographic plate at *O*. The γ -rays strike the crystal at all angles but only those which fall upon it in such a way that the angle between them and the reflecting planes is the glancing angle for the particular wave length will be reflected. The rays are thus left as it were to pick out their

own reflecting planes, and beams of reflected rays AB and $A'B'$ will emerge from the crystal and fall on the photographic plate.

Neglecting the absorption of the crystal, which will be very small, the energy in the primary beam must be equal to the energy transmitted plus the energy reflected. Hence a ray such as RA which is selectively reflected will suffer a much greater loss of energy in going through the crystal than rays which pass through without any loss by reflection. Thus in the direction RA produced the rays will be relatively enfeebled and thus the effect on the photographic plate will be small. The reflecting plane thus casts a shadow on the photographic plate at a point C in the direction RA produced. Similarly the plane A' casts its shadow at C' . It is evident that the angle CAB subtended by the distance between corresponding bright and dark lines at the crystal is equal to twice the glancing angle for the rays. In this way by measuring the distance CB on the plate and the distance of the plate from the crystal the angle of selective reflection for the rays used can be accurately determined.

The values of the glancing angle for the γ -rays from the mixture of radium B and radium C used for the experiment ranged from $44''$ to 4° . The corresponding wave lengths ranged from 0.71×10^{-9} to 4×10^{-9} cm. The most penetrating rays had thus about one-eighth of the wave length of the characteristic K radiation of silver.

CHAPTER XIII

RADIO-ACTIVE CHANGES

115. **Disintegration of uranium.** We have already considered the nature of the radiations emitted by radio-active substances. We must now investigate more closely the nature of radio-activity itself. Uranium supplies us with perhaps the simplest case. Uranium and its salts were found to give off both α - and β -rays, γ -rays of small intensity attending the latter. Using a thick layer of the substance practically the whole of the effect on a photographic plate is due to the β -radiation, since owing to the great absorbability of the α -rays only those from a comparatively thin layer can reach the surface and at the best of times the photographic effect of an α -ray is small. In 1900 Sir Wm. Crookes shewed that it was possible by a single chemical operation to obtain uranium which was photographically inactive, while the whole of the photographic activity was concentrated in a very small residue, free from uranium and consisting chemically of the small traces of the impurities present in the original salt. This residue to which he gave the name of uranium X could be obtained many hundred times as active weight for weight as uranium itself, while the major fraction which could be shewn by chemical tests to be uranium was photographically inactive. The method originally used was to precipitate the uranium with ammonium carbonate and to dissolve the precipitate in excess of the reagent. On filtering a trace of precipitate remained behind on the filter paper. This contained the uranium X. The same separation can also be carried out by other methods. So far the phenomena resemble very closely the separation of two ordinary chemical substances by the usual methods of analysis. However, if the two fractions are laid aside for two or three months it is found that the uranium has recovered the whole

of its original activity while that of the uranium X has completely disappeared. The loss of activity of the uranium was therefore only temporary in character, while the increased activity of the separated uranium X was equally short lived.

It was further found that the total activity, as measured by the photographic effect, that is, by the β -rays, was constant at any time before or after the separation, the gain of activity of the uranium exactly corresponding to the loss of activity of the uranium X. The measurements are most conveniently made by the electrical method. The substance to be examined is spread in a thin layer over the lower plate *B* of the parallel

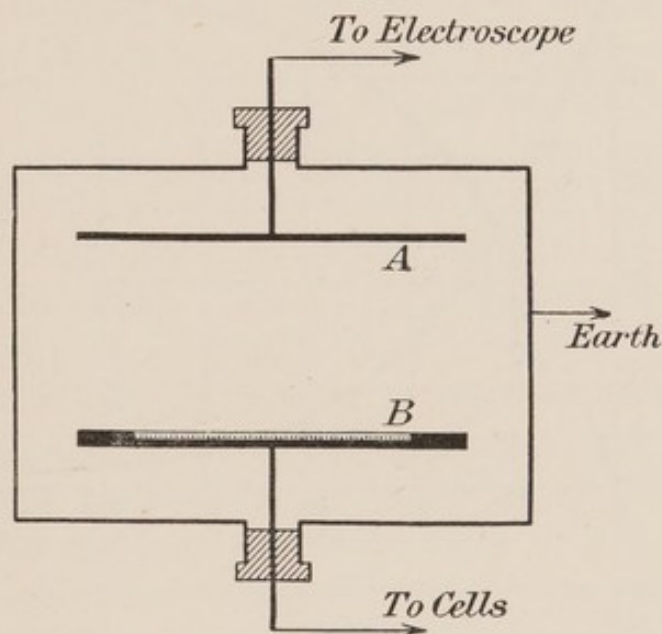

Fig. 88

plate ionization chamber (Fig. 88) which is used as the high potential plate and connected to a battery of cells. The upper plate *A* is connected to the electrostatic or electrometer, and the saturation current is measured in the usual way. The saturation current is taken as proportional to the activity of the substance. In order to be comparable with the photographic effect, which we have been describing and which as has been pointed out is due to the β -rays, the substance must be covered with 1/10 mm. of aluminium to cut off all the α -radiation.

Using two chambers of this type we can investigate more closely the change of activity with time in the two fractions. The results for uranium are shown in Fig. 89. The two

curves are complementary, the sum of the two ordinates at any point being the same.

By plotting the *logarithms* of the currents against the time it is found that the decay curve of the uranium X follows an exponential law, that is, if I_t is the activity at a time t , then

$$\frac{I_t}{I_0} = \epsilon^{-\lambda t} \quad . \quad . \quad . \quad . \quad . \quad (105)$$

where I_0 is the activity at the moment when the measurements began, and λ is a constant, which is known as the *radio-active constant* for the particular substance, in this case uranium X.

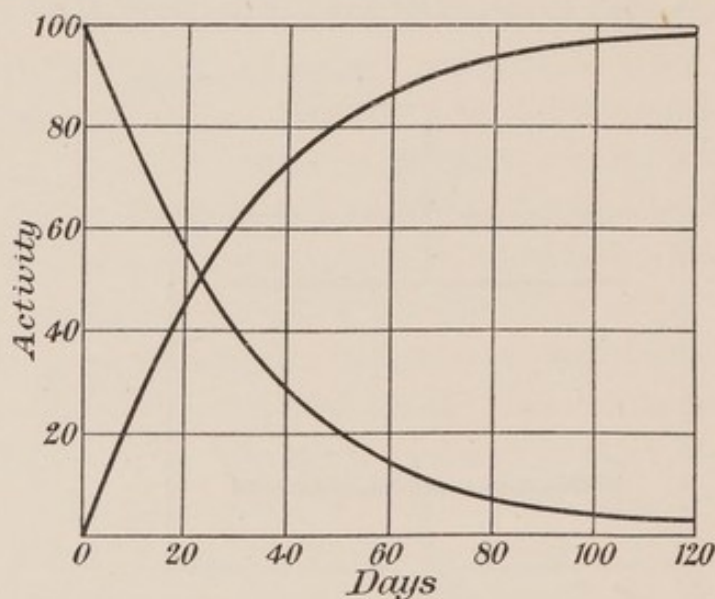

Fig. 89

Since the curves are complementary the recovery curve for the uranium can be expressed in the form

$$\frac{I_t}{I_0} = 1 - \epsilon^{-\lambda t} \quad . \quad . \quad . \quad . \quad . \quad (106)$$

where t is the time which has elapsed since the uranium was completely freed from uranium X, and λ is the same constant as before.

Differentiating the expression for the decay of uranium X we have

$$\frac{dI}{dt} = -\lambda I_0 \epsilon^{-\lambda t}.$$

But $I_0 \epsilon^{-\lambda t}$ is the quantity of the uranium X still present = I , say. Thus

$$\frac{dI}{dt} = -\lambda I. \quad . \quad . \quad . \quad . \quad . \quad (107)$$

In other words *the rate of decay at any moment is simply proportional to the quantity of radio-active matter still present*, a very important result.

The uranium which has been freed from Ur. X is inactive as measured by its β -ray effect. If, however, we remove the aluminium screens from the two fractions in Fig. 88 we find that the ionization is now nearly all due to the uranium itself, the activity of the separated fraction being negligible in comparison with that of uranium itself. In other words uranium itself gives out α -rays but no β -rays while the uranium X gives out β -rays but no α -rays.

The rate of decay of activity of the Ur. X has been shewn by many experiments to be quite independent of external conditions. It is the same whether the two fractions are kept separate or whether they are enclosed in the same tube; the same whether the product is exposed to the air or sealed in a thick walled lead box, so as to be freed as far as possible from all external influences. It is quite independent of temperature being the same at the temperature of liquid air as at a red heat. It does not depend on the processes used for the separation of the two substances and is therefore presumably independent of the state of combination of the substance. The growth of activity of the uranium salt is the same if it is changed into some other salt of the metal, or whether it is solid or in solution. It is in fact a constant of the substance itself.

116. Theory of radio-active change. It is at first sight somewhat remarkable that the processes of recovery and decay should be so closely connected even when the two fractions are separated from each other in such a way as to preclude all possibility of interaction between them. The effects however have found a complete explanation on the following assumptions.

- (1) That there is a constant production of the new radio-active substance (Ur. X) by the radio-active body (uranium).
- (2) That the new substance (Ur. X) itself disintegrates according to an exponential law, with a constant equal to the radio-active constant λ for the change.

Suppose that from the given mass of uranium q_0 particles of uranium X are produced per second. The activity of the particles produced in a short interval of time dt will at their moment of production be equal to $Kq_0 dt$, where K is a constant measuring the effect produced on our electroscope by one particle of Ur. X. The activity of these particles after a time τ will be given by

$$Kq_0 \epsilon^{-\lambda\tau} = dI. \quad . \quad . \quad . \quad . \quad (108)$$

Suppose we wish to know the total activity of the uranium at a time T after it has been completely freed from the product Ur. X. Then the time which has elapsed since the formation of the particular particles we are dealing with is equal to $T - t$ where t represents its moment of formation. The effect due to these particles is thus $Kq_0 \epsilon^{-\lambda(T-t)}$ and the total activity at the time T is therefore given by

$$\begin{aligned} I_T &= \int_0^T Kq_0 \epsilon^{-\lambda(T-t)} dt \\ &= \frac{Kq_0}{\lambda} (1 - \epsilon^{-\lambda T}). \quad . \quad . \quad . \quad . \quad (109) \end{aligned}$$

The maximum activity is reached when the process has been going on for a sufficient time to make $\epsilon^{-\lambda T}$ negligible, and is given by

$$I_0 = \frac{Kq_0}{\lambda}.$$

Calling this value I_0 we have

$$\frac{I_T}{I_0} = 1 - \epsilon^{-\lambda T}$$

which agrees with the experimental results. It will be noted that λ is the constant measuring the rate of decay of the product.

The equilibrium state is obviously reached when the loss of activity due to decay of the product is equal to the rate of formation of the product from the original substance. Since the product is always decaying according to the exponential law, whether it is mixed with the parent substance or separated from it, it follows that uranium is constantly producing a new substance uranium X from itself at a definite constant rate. When equilibrium has been established it is evident that the

quantities of the two substances present will bear a constant ratio to each other.

The possibility of separating uranium X from uranium in various chemical ways shews that the two substances are chemically distinct. This is still more obvious in the case of radium, in which, as we shall see, the first product of the radio-active change is a gas. Moreover, the uranium not only gives uranium X but in the process emits α -particles which, as we have already seen, are material in nature, being neither more nor less than charged atoms of helium. It is impossible in view of these and many other facts which will appear throughout the discussion to avoid the conclusion that the atom of uranium disintegrates, spontaneously giving off a charged helium atom and forming a new element uranium X which, although owing to its rapid decay it is always present in quantities too small to admit of direct chemical investigation, can be detected by the β -radiations which it emits. The product of the decay of uranium X has been identified as a new radio-active substance, Ionium, which in its turn is proved to be the origin of the element radium. Owing to the relation between the radio-active constants of the various products the investigation of this sequence has proved difficult. We will therefore postpone its consideration until we have considered the case of radium itself in which owing to its intense activity, and to special circumstances which render the separation of the various products easy, the phenomena of successive changes are easier to follow.

117. Theory of successive transformations. The case we have so far considered has been a very simple one for two reasons. In the first case the amount of uranium breaking up during the time of our experiments is so infinitesimally small that we can without error regard the amount of uranium present during the experiment as constant. In the second place the substance formed by the disintegration of the uranium X is so feebly radio-active that its effect upon the electroscope is inappreciable. In general these simple conditions do not hold. Radium, for example, which has been prepared for more than a few days

is found to contain at least five radio-active substances whose activity must be taken into account. The same principles which were successful in explaining the decay and recover curves of uranium and its product can also be applied to the more complex cases with equal success. For convenience these principles have been stated in the form of six propositions by Sir Ernest Rutherford, to whom the theory is due.

(1) The activity shewn by radio-active substances is due to the disintegration of the atom.

(2) A definite fraction of the total number of atoms present become unstable in a given small interval of time.

(3) In most cases this instability and disintegration is accompanied by the emission of energy in the form of α -, β - and γ -rays, by α -rays alone or by β - and γ -rays alone. Occasionally it takes place without emission of ionizing radiations. If radiations are emitted it is assumed that the fraction of the atoms changed per second can be measured by the intensities of the radiations emitted.

(4) The expulsion of a single α -ray of atomic weight 4 gives rise to an atom differing in atomic weight by four units from the parent atom. The expulsion of β -particles, which have a mass insignificant compared with that of a hydrogen atom, produces no change in atomic weight, but only in the internal structure of the atom.

(5) At any time after disintegration has commenced there exist together in the substance

(a) the unchanged substance,

(b) the immediate product of its disintegration of the same or smaller atomic weight,

(c) any product or products formed from the disintegration of (b) if it is itself radio-active.

(6) Each of the products of radio-active change is a new element, and has different chemical properties from those of the parent atom. This is shewn by their different behaviour to various chemical reagents as in the case of uranium. It is still more clear in the case of radium in which the first decomposition product is a gas.

The general problem may be stated as follows: Suppose we

have a series of elements A, B, C, D, \dots such that A changes into B , B into C , C into D , and so on. Given that the number of atoms of each present at a given moment in a substance is a, b, c, d, \dots respectively to find the number of each still present in the mixture after a time t has elapsed. The general problem is capable of solution, but it will be simpler and more instructive to confine our attention to one or two illustrative cases which are met with in actual practice.

By assumption (2) we have for each of the substances

$$dn/dt \propto n,$$

where n is the number of atoms of that substance actually present at the given moment. Thus

$$\frac{dn}{dt} = -\lambda n; \quad n = n_0 e^{-\lambda t}, \quad . \quad . \quad . \quad (110)$$

that is to say, each element by itself decays according to an exponential law. λ is known as the radio-active constant for the substance.

We shall see later that the decomposition of the atoms follows a probability law, and that λn is only the most probable value of the number disintegrating per second. When, however, as is usually the case, the total number of atoms is large, the actual value over a finite interval of time will not differ from its most probable value by an appreciable amount.

It must be noted that λn is also the rate of formation of the new substance B . We have already seen that λ is independent of the most extreme changes in external and chemical conditions. It is also independent of the age of the substance. Experiments have been made with radium emanation which loses half its activity in 3.85 days, over a period exceeding three months. The rate of decay throughout was strictly exponential, the constant λ being the same at the end of the experiment as at the beginning. It is thus the same for emanation which is freshly formed as for emanation three months old. In fact the break up of the atom depends solely on the law of probability and the nature of the atom.

Two other ways of defining the rate of decay of the radio-

active substance are often used. The *half period value* is the time taken for the activity of the substance to fall to one-half its original value. This can be obtained from (110) by putting $n/n_0 = \frac{1}{2}$ and solving for t . Thus $-\lambda t = \log_e \frac{1}{2}$,

$$t = \frac{\log_e 2}{\lambda} = \frac{0.693}{\lambda} \dots \dots \dots (111)$$

The *average life* of the radio-active atom can also be calculated. The number of atoms changing per second at a time t since the separation of the substance = $\lambda n dt$. Also $n = n_0 e^{-\lambda t}$ and thus $dn = \lambda n_0 e^{-\lambda t} dt$. These atoms have had a life of t seconds. The average life of all the atoms of the substance is therefore

$$\begin{aligned} \frac{1}{n_0} \int_0^\infty t \lambda n_0 e^{-\lambda t} dt \\ = \frac{1}{\lambda} \dots \dots \dots (112) \end{aligned}$$

118. Radio-active equilibrium. Suppose we commence with some substance such as uranium or radium the life of which is comparatively long compared with the time occupied by our experiments. The average life of uranium, for example, is about 7×10^9 years and that of radium about 2880 years. Over any ordinary period of time therefore the quantity of the original radio-active substance which we will call A remains constant, and hence fresh radio-active matter is produced from it at an approximately constant rate, which will be equal to $\lambda_1 a_0$ where a_0 is the number of atoms of A present, and λ_1 its radio-active constant. If B is the immediate disintegration product of A , B is being formed in the substance at this constant rate $\lambda_1 a_0$. But the rate at which B disintegrates is proportional to the amount of B actually present, and thus increases with the increase in the quantity of B . Hence a point will come when the rate of disintegration of B is equal to its rate of formation from A and the amount of B in the substance will then remain constant. The rate at which B increases is equal to the difference between its rate of formation from A and its rate of disintegration into C . Thus

$$db = \lambda_1 a_0 dt - \lambda_2 b dt \dots \dots \dots (113)$$

where b is the number of atoms of B present at the given instant. Similarly for the element C we have

$$dc = \lambda_2 b dt - \lambda_3 c dt.$$

It is evident that the amounts of B, C, \dots present in the mixture will become constant when

$$\lambda_1 a_0 = \lambda_2 b = \lambda_3 c = \dots \dots \dots (114)$$

Thus when radio-active equilibrium, as it is called, has been established the various radio-products will bear to each other a constant ratio which is inversely proportional to their radio-active constants. Conversely, if on analysis two radio-active substances are always found occurring in nature in the same ratio, one of them must be a product, direct or indirect, of the other. Thus the fact that the proportion of radium to uranium in minerals is always constant is evidence that radium is a product of the disintegration of uranium.

A hydrostatic analogy may prove useful in understanding the process. Suppose we have a series of tanks P, Q, R, \dots emptying one into the other as shewn in Fig. 90. The rate at which water flows out of any tank will be proportional to the area of the aperture and to the height of the water in the tank at the moment under consideration. In other words, supposing the tanks to have the same area of cross section, the flow will be proportional to the quantity of water in the tank. The rate of efflux of the water thus follows the same law as the rate of decomposition of a radio-active substance.

Supposing now that the water in the tank P is kept at a constant level. This will correspond to the case we have just been considering. Water will rise in each tank until the rate of efflux, which is proportional to the quantity of water in the tank, is equal to the rate at which water pours into it from the tank above. When equilibrium is established the rate of flow will be constant throughout, and the height of the water in the

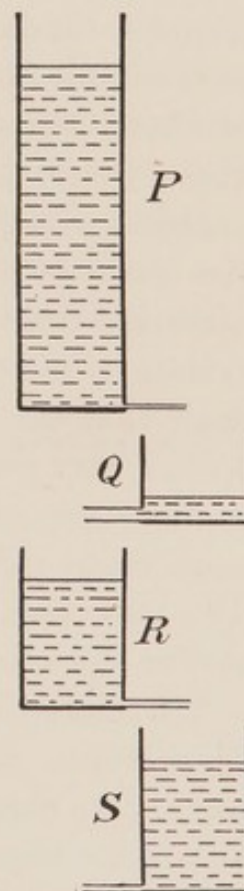

Fig. 90

different tanks will be inversely proportional to the size of their apertures. If the aperture is small the height of the water will be large, if on the other hand it is large a comparatively small height of water will produce the necessary efflux. Similarly when equilibrium is established substances of quick decay, for which the radio-active constant is large, will be present in relatively small proportions while those which decay slowly and for which the radio-active constant is small, will be present in large amounts. It is thus only the comparatively long-lived radio-active substances, such for example as radium itself, which we could expect to obtain in measurable quantities.

The case which we have just considered constitutes what may be described as permanent radio-active equilibrium, the amounts of each substance present remaining constant after equilibrium has once been reached. Let us suppose now that water is no longer poured into the first tank P , but that P has a small aperture so that the rate of efflux is small. This will correspond to the case of the decomposition of a radio-active substance of small but appreciable radio-active constant. The rate of flow of water through the system will obviously be governed by that of the tank with the smallest aperture, in this case by P . It is evident, therefore, that when equilibrium has been established the quantity of water in each tank will be proportional to the quantity remaining in P , since the rate of flow through the system is governed by this factor. A little consideration will shew that the relative amounts of water in the different tanks will be very nearly the same as if the level in P were maintained at the value which it has at the moment of observation by a continuous influx of water. It will actually be slightly larger. The two cases will approximate more nearly to each other the slower the rate of efflux from P .

We thus get a state which we may describe as that of *transient equilibrium*, the relative quantities of water in each tank remaining constant, but each of the quantities decreasing in absolute magnitude proportionately to the quantity in the first tank.

This case corresponds to that of a radio-active substance which gives rise by its disintegration to a series of radio-active

substances, the average life of which is short compared to its own. For example, radium emanation which has an average life of 5.55 days gives rise to successive radio-active substances which have average lives of 4.32 minutes, 38.7 minutes, and 28.1 minutes respectively. Thus, if radium emanation is placed in an enclosed space and left to decay, after equilibrium has been established, which takes place in about four or five hours, the quantity of any one of the products present is simply proportional to the quantity of the emanation remaining in the vessel. This is a case of transient radio-active equilibrium. It can be shewn that in this case the quantity of each product actually present is about one per cent. greater than the value which it would finally attain if the quantity of emanation present were maintained at its actual value at that instant by an external source.

The problems arising can easily be solved if required by an application of the principles enunciated by Rutherford.

Taking the case we have just considered for an example, suppose that A, B, C, \dots are a series of such elements so that A changes into B , B into C , and so on. Then if the substance at the beginning consists only of the element A (for example only of radium emanation), and if a, b, c, \dots are the number of atoms of each element present at a time t from the start, and $\lambda_a, \lambda_b, \lambda_c, \dots$ are the corresponding radio-active constants, we have

$$a = a_0 \epsilon^{-\lambda_a t}$$

where a_0 is the number of atoms of A with which we commenced the experiment. Also by (113) we have

$$db = \lambda_a a dt - \lambda_b b dt,$$

$$dc = \lambda_b b dt - \lambda_c c dt,$$

and so on. Substituting for a , we have

$$\frac{db}{dt} = \lambda_a a_0 \epsilon^{-\lambda_a t} - \lambda_b b.$$

The solution of this equation is of the form

$$b = a_0 (k_1 \epsilon^{-\lambda_a t} + k_2 \epsilon^{-\lambda_b t}). \quad \dots \quad (115)$$

Now $b = 0$ when $t = \infty$, since all the substances eventually disintegrate completely; $\therefore k_1 = -k_2$. Differentiating the equa-

tion and applying the conditions that when $t = 0$, $a = a_0$ and $b = 0$, we find $k_1 = \frac{\lambda_a}{\lambda_b - \lambda_a}$; and thus finally

$$b = \frac{a_0 \lambda_a}{\lambda_b - \lambda_a} (\epsilon^{-\lambda_a t} - \epsilon^{-\lambda_b t}). \quad . \quad . \quad (116)$$

The method can obviously be continued to give the corresponding value of c , and so on. If λ_b is large compared with λ_a , then when t is comparatively large $\epsilon^{-\lambda_b t}$ will be small compared with $\epsilon^{-\lambda_a t}$ and the quantity of b present will thus be proportional to $a_0 \epsilon^{-\lambda_a t}$, that is, to the quantity of A remaining; the result we have already obtained from general considerations.

CHAPTER XIV

RADIUM AND ITS PRODUCTS

119. **The nature and properties of radium.** The principles we have been considering will be made clearer, and the evidence for them more conspicuous, if we study in detail one series of radio-active changes. That of radium is the most suitable for the purpose, not merely on account of its intrinsic importance but also owing to various accidental causes which render the phenomena particularly clear.

Radium can be isolated from uranium ores, in which it exists as a product of the radio-active disintegration of the uranium. It is obtained by the processes used in the extraction of barium from the ores, to which element it bears a close chemical resemblance. It can be obtained free from barium by repeated fractional crystallization of the bromide, the radium salt being somewhat less soluble in water than the corresponding salt of barium, with which, however, it is isomorphic.

The proof of the elementary nature of radium is now complete. It is afforded, in the first place by the spectrum, which is characteristic of the metal, and differs from those of all other elements. The lines in the radium spectrum have now been analysed into their component series, and are found to present the common characteristics of the metals of the alkali earths. Applying the usual laws of spectra the spectrum of radium is found to correspond to that of an alkali earth metal of atomic weight about 225.

Radium has now been obtained in sufficient quantities and of sufficient purity to enable its atomic weight to be obtained by direct chemical methods. The method employed is that of precipitating the radium chloride with silver nitrate, and weighing the silver chloride formed. By repeated crystallization Madame Curie obtained a product so pure that the strongest

barium line was only feebly visible in the spectrum of the salt. In this way the atomic weight was found to be 226.4. Other recent determinations give values ranging from 225.95 to 226.45. The atomic weight of radium may thus be regarded as known within these narrow limits.

The value of the atomic weight of radium is strong evidence for the disintegration theory of its formation. It is known that the conversion of uranium into radium is attended with the expulsion of three α -particles, each of which has an atomic weight of 3.99. Thus on the disintegration theory the atomic weight of radium should be less than that of uranium by the weight of three α -particles or atoms of helium. The atomic weight of uranium is 238.5. That of radium should therefore be $238.5 - 3 \times 3.99$, or 226.5, in satisfactory agreement with the chemical determinations.

Radium can be obtained in metallic form. It is a silver white metal, melting at about 700° C., and beginning to volatilize at a slightly higher temperature. It is attacked by air forming a nitride, and by water forming the hydroxide. It forms a series of salts similar in properties and appearance to those of barium. It thus possesses in every particular the characters of a metallic element of the alkali earth group.

120. Radium emanation. The first product of the disintegration of radium is the heavy inert radio-active gas known as radium emanation. It is found that a sample of pure radium emits this gas at a constant, definite rate, the emission being attended by the expulsion of an α -particle. The phenomena of radio-active change are peculiarly striking in this instance, the parent substance being a metallic solid, while the disintegration product is an inert gas, which can thus be easily separated from it by purely physical means.

The existence of a radio-active gas was first recognized in the case of thorium. It was noticed that the measurements of the activity of this substance were liable to peculiar fluctuations, being for example much diminished in a strong draught of air. The phenomena were finally traced by Rutherford to the emission by the thorium of a substance which was carried

about by the air currents, and thus gave rise to the observed peculiarities. In order not to prejudice future investigation these products were called "emanations," a name which has stuck to them in spite of subsequent research. They are now known to possess all the properties of ordinary gases of high atomic weight.

Investigation of radium salts immediately shewed that a similar emanation was given off by radium. Owing to its comparatively long life (it decays to half value in about 3.85 days) this emanation is more easily investigated than that from thorium which decays to half value in less than one minute. Radium emanation is itself radio-active. It gives off α -particles changing into a substance, radium A, which being solid is deposited on the walls of the vessel containing the gas.

121. Elementary nature of radium emanation. Radium emanation, though formed from radium, is itself an element. This is shewn by its characteristic spectrum, which differs equally from that of radium as from the spectra of all other elements. The spectrum can easily be obtained by passing a little of the emanation into a small discharge tube. The colour of the discharge is bluish, and shews numerous bright lines differing from those of all other elements.

Since the emanation is formed from radium by the expulsion of an α -particle of mass 3.99 its atomic weight should be about 222.5, taking that of radium as 226.5. The matter has been investigated directly by Ramsay and Gray, who succeeded in determining the density of the emanation using a quartz microbalance of special construction. For details of this brilliant piece of experimental work reference should be made to the original paper. The principle of the balance is simple. Two bulbs of very unequal size but of equal mass are placed at the two ends of the beam of a small quartz balance enclosed in a small air-tight chamber. The weights are adjusted so that the beam is horizontal when the balance case is completely evacuated. If gas is now admitted to the space around the balance the buoyancy of the gas will reduce the effective mass of the larger bulb, and thus cause a deflection of the beam.

The buoyancy of the gas can be calculated in terms of the deflection of the beam when the sensitivity of the balance is known, and from the buoyancy the density of the gas can be at once determined.

The mean result of several experiments shewed that the density of the emanation was 111.5 times that of hydrogen. This gives a molecular weight to the emanation of 223. The chemical properties of the gas resemble those of the argon group, and it is thus presumably monatomic. In this case its atomic weight is also 223. Considering that the total weight of the emanation available for the experiment was no more than 1/1000 of a milligram the agreement with the theoretical value is surprisingly good.

The emanation has been found to behave as a gas at ordinary temperatures. It obeys Boyle's law, it liquefies at -65° C. at normal pressure, but exerts an appreciable vapour pressure down to a temperature of -150° C. According to Ramsay and Gray its critical temperature and pressure are 104.5° C. and 63 atmospheres respectively. The density of the emanation at the temperature of liquid air, at which it is probably solid, is between 5 and 6.

Radium emanation is thus a definite chemical element belonging to the group of inert gases. Sir W. Ramsay proposed to emphasize this fact by giving it a separate name, Niton. The proposal, although desirable, has not met with general acceptance.

122. Rate of decay of radium emanation. As radium emanation is extensively used in experimental researches it is necessary to know its rate of decay with some accuracy. The simplest method is to allow the emanation in a closed tube to attain radio-active equilibrium with its immediate products radium A, B and C. These products are all short-lived, the most stable having a half period value of 26.8 minutes. A few hours thus suffices to set up transient equilibrium in the system. The rate of decay of any part of the activity is then, as we have already seen (§ 118), that of the most stable of the constituents, in this case the emanation. The advantage of this method is

that it allows us to use the β - and γ -rays, which, as we shall see later, are actually emitted by its disintegration products, radium B and radium C, as a measure of the activity of the emanation itself. It further allows us to evade the complications due to the growth of these products in the emanation during the first few hours after separation.

The apparatus used by Curie is shewn in Fig. 91. The radium emanation, enclosed in a sealed glass tube *A*, is placed inside the brass tube *B*, which can be connected to a battery of cells and forms one plate of the ionization chamber. The

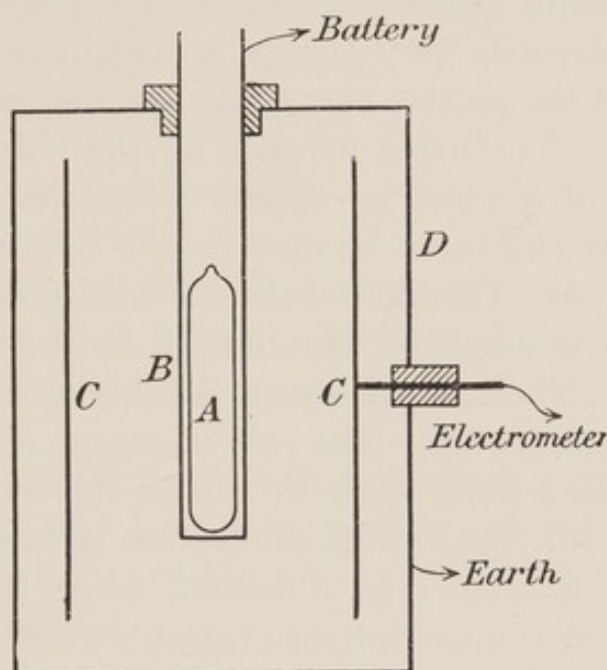

Fig. 91

insulated plate *C* takes the form of a cylinder concentric with *B*, and is connected in the usual way to an electrometer. The whole is surrounded by a metal chamber *D* which is earthed and serves to screen *C* from electrostatic disturbances. If *D* is made perfectly air-tight, changes in the current owing to fluctuations in the temperature and pressure of the atmosphere are avoided. The α -rays due to the emanation itself are of course completely absorbed by the glass tube *A* and the metal tube *B*. The current is due to the β - and γ -rays from the radio-active decomposition products of the emanation. After a few hours these decay with the period of the emanation.

In this way the radio-active constant of the emanation was

found to be $0.1801 \text{ (day)}^{-1}$ or $2.085 \times 10^{-6} \text{ (sec.)}^{-1}$. Rutherford by a different method obtained a value $0.1802 \text{ (day)}^{-1}$. The value of λ may thus be regarded as known to approximately one part in a thousand. It corresponds to a half value period of 3.85 days.

123. Rate of escape of the emanation. The rate of production of the emanation is simply proportional to the quantity of radium present. It follows the usual radio-active laws, and is independent of conditions. The rate at which the emanation escapes from the radium is, however, quite a different matter and depends very largely on conditions. If the compound is solid the greater part of the emanation is occluded by it. The amount occluded depends on the nature of the salt, and the area of it which is exposed to the air. A considerable fraction of the emanation escapes from a thin layer, much less from a thick one. The bulk of the occluded emanation is given off if the salt is dissolved, especially if air is bubbled through the solution. The rate of escape is also much increased by raising the temperature. The rate of escape of the emanation can be increased forty times by raising the temperature from -80° to 800° C. The rate of production is, however, constant throughout the range, the difference being that at the low temperatures the emanation disintegrates within the substance, while in the latter it is given off into the space above the radium before disintegrating. Similar results are obtained with thorium and thorium emanation.

124. Measurement of the volume of the emanation in equilibrium with one gram of radium. The quantity of emanation in radio-active equilibrium with one gram of radium is by the laws of radio-active change a definite amount. It is termed a *curie*. Since the curie is a somewhat large standard compared with the amounts of emanation generally available for experimental purposes one-thousandth part of this is taken as a subsidiary standard and is known as the *millicurie*. The value of the curie can be estimated from the radio-active constants. It has been found by the method of § 98 that one

gram of pure radium (free from its products) emits 3.4×10^{10} α -particles per second. As each atom of radium disintegrates into one atom of emanation with the expulsion of one α -particle this is also the number of emanation atoms formed per second. But the number present when equilibrium is reached is equal to q/λ where q is the rate of formation of the atoms, and λ the radio-active constant of the emanation. The total number of atoms of emanation in equilibrium with one gram of radium is thus

$$3.4 \times 10^{10} / 2.085 \times 10^{-6} = 1.63 \times 10^{16}.$$

Since there are 2.78×10^{19} molecules in one c.c. of gas at normal temperature and pressure the volume occupied by one curie of emanation under these conditions is

$$1.63 \times 10^{16} / 2.78 \times 10^{19} \text{ c.c.} = 0.59 \text{ cubic mm.}$$

This value has been confirmed by direct experiment, the purified emanation from a known weight of radium being passed into a calibrated capillary tube. The observed value agreed closely with that calculated, again affording further proof of the correctness of the principles involved.

125. The active deposit from radium emanation. If a plate or wire of any kind is exposed to radium emanation for a few hours and then withdrawn it is found to have become radio-active, the more concentrated the emanation the greater the activity. This phenomenon was at first described as induced or excited activity. It is now known to be due to the deposition on the surface of the substance of a radio-active product due to the decomposition of the emanation.

If the wire is allowed to remain in the emanation sufficiently long to attain equilibrium the amount of the activity is independent of the position or material of the plate, and is strictly proportional to the amount of emanation present. It is also directly proportional to the area of the surface exposed.

A curious property of the excited activity is that it can be concentrated on a very small area if the latter is charged negatively. Thus if a wire *B* (Fig. 92) is passed into a metal chamber *A* containing a radium compound, and charged to a high potential, the activity when the charge on the wire is

negative is as much as 200 times its activity when positively charged. In this way practically the whole of this "excited" activity can be concentrated on the wire, which may be made to have an activity per unit area of over 10,000 times that of the surface of the radium itself.

Since the activity is concentrated on the negative electrode the carriers of the activity must have a positive charge. Since the active deposit is formed from the emanation by the emission of a positive particle carrying two electronic charges we should have expected the residual atom to have been negatively charged. We know, however, that the impact of a positive particle on matter gives rise to a number of slow-moving electrons, or δ -rays as they have been called. It seems evident,

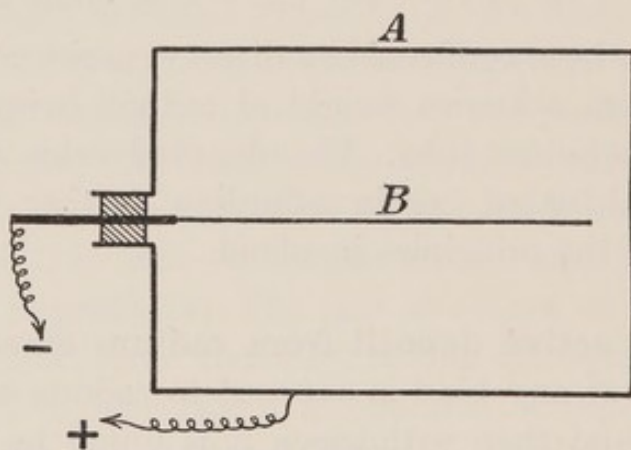

Fig. 92

therefore, that the escape of a positive ray from an atom must also be attended by an emission of negative electricity, probably in the form of these slow-moving electrons. Since the residual atom has a positive charge it is evident that at least three such electrons must be expelled with each positive particle.

These positively charged carriers move under the electric field in the same way as the ions in a gas, and similarly lose their charges owing to recombination with the negative ions in the gas. Thus if the potential of the negative electrode is gradually increased the activity on the electrode increases in almost exactly the same way as the current through an ionized gas, the activity reaching a constant maximum when the field is sufficiently large to convey all the carriers to the negative electrode before any appreciable recombination has taken place.

The velocity of the carriers in an electric field can be measured by methods analogous to those used to determine the mobilities of the ions. Their velocity in a field of one volt per cm. is about 1.4 cm. per sec. or very nearly that of the positive ion in a gas. There is some evidence for the assumption that they carry a single negative charge.

126. Recoil atoms. The α -particle is expelled from the emanation atom with considerable velocity. The residual atom itself must thus be projected in the opposite direction with a velocity which is given by the consideration that the momentum of the system as a whole must be zero. Since the mass of the α -particle is 4, and that of the residual atom (222 - 4), the velocity of the recoil atom will be $4/218$ or about $1/55$ of that of the corresponding α -particle. These recoil atoms as they are termed are brought to rest in passing through a gas in exactly the same way as the α -particles. Owing to their much smaller velocity, however, their range is considerably less.

Owing to the high kinetic energy of the recoil atoms the electric field has little effect upon them until they have been reduced to rest by the surrounding gas. They then behave as ordinary charged ions and are dispatched to the negative electrode. Hence if the pressure in the vessel is reduced so low that the recoil atoms can reach the walls of the vessel before coming to rest the distribution of the activity will be uninfluenced by an electric field, the cathode having no larger share of the activity than the rest of the chamber, and the activity is then uniformly distributed. This has been shewn to be the case experimentally, the pressure at which it occurs in ordinary sized vessels being of the order of 1 mm. The range of the recoil atoms, as of the α -particles, is directly proportional to the pressure of the gas. Thus the range of the recoil atoms can be deduced by the method described in § 99. It is found to be about 0.12 mm. in air at atmospheric pressure and about 0.7 mm. in hydrogen. The velocity of the recoil atoms has been measured directly, and found to be in good agreement with that deduced from a consideration of the range, and with that to be expected from the theory of their origin stated above.

127. Analysis of the active deposit of rapid change. A body which has been exposed to radium emanation is found after removal from the emanation to give out all three kinds of radiations. The activity is comparatively short-lived and almost completely disappears within 24 hours after withdrawal from the emanation. There is, however, always a small residual activity which if the body has been exposed to emanation for several days may reach as much as one-millionth of the initial activity, and the activity of this portion is found to increase steadily with time over the space of several years.

We may therefore for convenience divide the excited activity into two parts, (1) the active deposit of rapid change, (2) the active deposit of slow change. Since the activity of the latter is in general minute compared with that of the former, we may neglect the small residual effects due to it in our analysis of the short-lived deposit.

For experimental purposes it is convenient to obtain the deposit on a wire or thin rod. This may be done in the apparatus shewn in Fig. 92. The central wire *B* is raised to a high negative potential, and radium emanation is passed into the apparatus. The bulk of the active deposit collects on the negative wire *A*. If the activity is to be measured by the α -rays the rod may then be made the central electrode of a cylindrical ionization chamber, the saturation current being measured by an electrometer in the usual way. If β - or γ -rays are to be used to measure the activity a simple electroscope of the type described in § 112 (Fig. 86) is convenient. If β -rays are to be employed the opening of the electroscope is covered with only sufficient thickness of aluminium foil to absorb all the α -rays. If only γ -rays are to be dealt with the electroscope may be placed on a sheet of lead some half centimetre in thickness, which will cut off every thing except the γ -rays.

The shape of the decay curves depends on whether the α - or the β -rays are used for the measurement, and also on the time of exposure of the wire to the emanation. The active deposit consists therefore of a mixture of radio-active substances, all in the solid state, some emitting α -rays, and some β - and γ -rays only.

The decay curve obtained after a short exposure of the wire

to the emanation, and measured by the α -ray activity, is shown in Fig. 93. It will be seen to be divisible into three parts. The first stage shows a rapid decay falling to some 10 per cent. of its initial value in 15 minutes. This is followed by a period of some 20 minutes in which there is little variation in the activity. Then a gradual exponential decrease follows, the curve falling to half value in about 28 minutes.

Since the exposure was short the initial substance consisted almost entirely of the first decomposition product of the

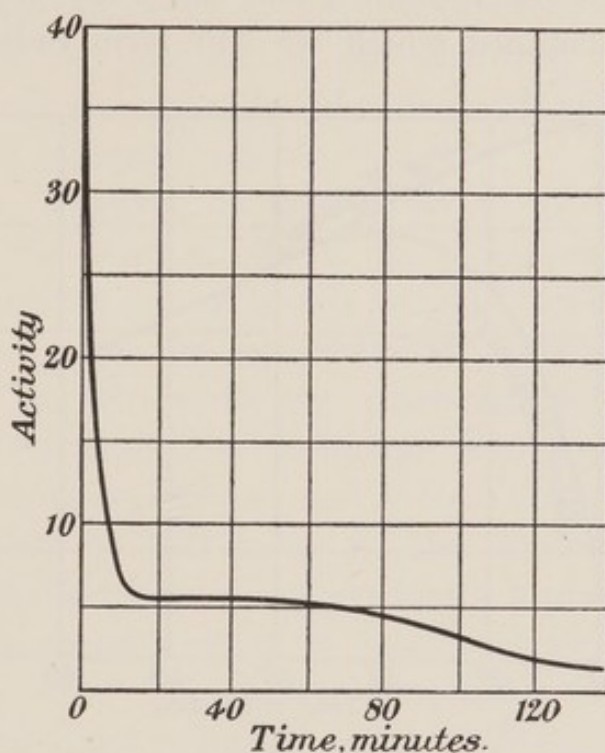

Fig. 93. Decay of excited activity; α -ray curve

emanation which we will call radium A. An analysis of the first part of the decay curve shows that this substance emits α -particles and decays to half value in about three minutes, giving rise to a product which emits α -rays and decays with a half value period of 28 minutes.

Further evidence on the nature of the changes can be obtained from a study of the β -ray curves. The β -ray curves for short and long exposures are shown in the curves of Fig. 94. The curve for a short exposure of one minute shows that the β -ray activity is initially absent, and that therefore radium A emits only α -rays. If, however, the product emitting the β -rays was

the immediate product of the decomposition of the radium A, the curve for the rise of activity of the β -ray product should be (neglecting the decay of the latter) complementary to the decay curve of radium A, that is, it should rise to half value in about three minutes. As a matter of fact the rise to half value occupies rather more than ten minutes and a substitution of the numerical values in the formulae shews that this discrepancy cannot be explained by the small decay of the β -ray product in that interval of time. We are thus led to the conclusion that there is between the radium A and the β -ray product another radio-active substance which we will term radium B, which

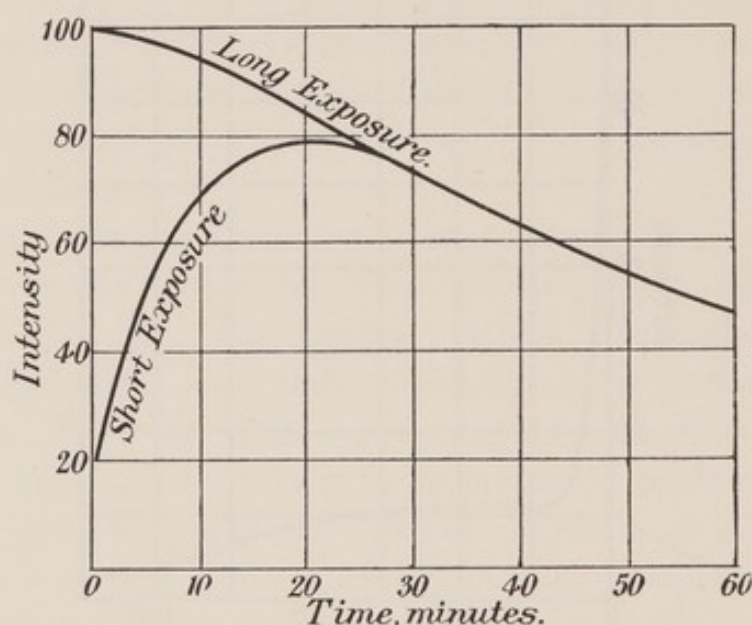

Fig. 94

without itself emitting ionizing rays gives rise to the product radium C which does.

The period of the two products radium B and C can best be obtained from a study of the curves obtained for the β -ray activity with long exposure. In this case the three products will be in radio-active equilibrium, and the relative amount of the short-lived radium A will consequently be very small. Moreover as it has a short period it will rapidly cease to affect the shape of the decay curves. The whole of the radium A (except one per cent.) is, in fact, disintegrated within twenty minutes after removal from the emanation and the curve is then due solely to radium B and C.

Now it is found that this curve can be accurately expressed by an empirical formula of the form

$$I_t/I_0 = a\epsilon^{-\lambda_3 t} - (a - 1)\epsilon^{-\lambda_2 t} \dots (117)$$

where a is a numerical constant and λ_3 and λ_2 have the values 5.38×10^{-4} and $4.13 \times 10^{-4} (\text{sec.})^{-1}$ respectively. It will be seen that the second of these gives a half value period of 28 minutes, the other a half value period of about 20 minutes.

Now we have already seen that the final rate of decay will be governed by the decay of the substance of longest period, irrespective of its position in the chain of decomposition. Hence we cannot immediately infer to which of the substances B or C the two constants refer.

Fortunately, however, it is possible to separate the two products. If the wire is heated to a temperature of some 600°C . surrounded by a cooled outer cylinder it is found that the activity can be separated into two parts, one part remaining on the wire while the other part is volatilized and condenses on the cool outer cylinder. The portion remaining on the wire emits α -radiation and β -radiation, the activity in each case falling to half value in 19.5 minutes. The other portion is initially inactive but gradually begins to emit both α - and β -rays corresponding to those of the substance left behind on the wire. The shorter period therefore corresponds with the final product, radium C, which emits both α - and β -rays, while the longer period 26.8 minutes is that of the radium B which without emitting radiations is the direct parent of the radium C and the immediate product of the decomposition of radium A.

The series of changes with which we are dealing can thus be represented by the following chain:

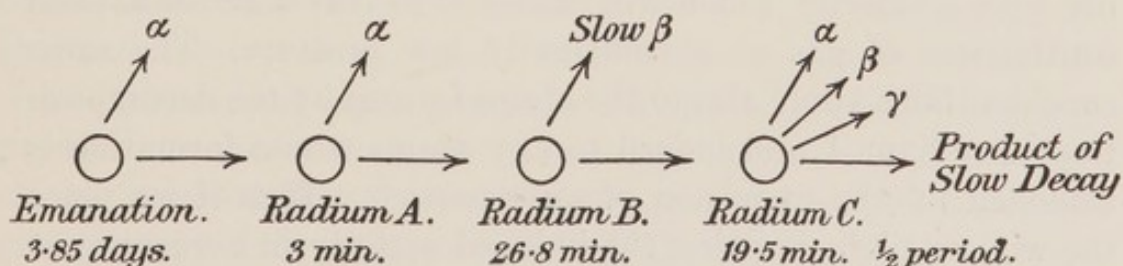

It has been found that the change from radium B to radium C is not entirely rayless. A quantity of slowly-moving β -particles comparable with the δ -rays are given off. These, however, have so little penetrating power that they are completely absorbed in the thickness of aluminium necessary to cut off the α -rays. Under the conditions under which the β -rays curves are generally measured they are therefore unable to enter the ionization chamber and hence exercise no effect on the shape of the curves for the β -ray activity. It is possible that all the changes described as rayless are really of this nature.

The theoretical shape of the various decay curves can be deduced from equations similar to those on page 224 since the various radio-active constants are known.

In order to test the adequacy of the disintegration theory the theoretical decay curves for the cases we have just been considering have been drawn by Rutherford, and compared with the decay curves obtained by actual experiment. The agreement of the two sets of curves was most satisfactory, the discrepancy being in general no more than one per cent. The theory of radio-active disintegration contained in the propositions in § 117 is thus completely adequate to explain even such complicated cases of radio-active change as those we have been discussing.

128. Separation of the products by the method of "recoil." Complex nature of radium C. Although the analysis of the radio-active product of short period was made in the manner explained above we have now a more powerful means of separating the various products of radio-active change. This can be done by making use of the "recoil" atoms already described. We have seen that the atom of radium A produced by the decomposition of radium emanation starts life with a velocity which will enable it to travel across several centimetres of gas at a sufficiently low pressure. The same considerations apply also to the atoms formed by the decomposition of radium A and indeed to any atoms whose formation is attended by the expulsion of an α -particle. Thus if we place the wire or plate carrying the induced activity in a vacuum at

a short distance from another inactive plate, the atoms of radium B formed by the decomposition of radium A will in many cases be shot across the intervening space, and collect on the inactive plate. In this way radium B of considerable purity can be obtained, since the atoms of radium C, which are formed from radium B with the emission of slowly moving β -particles only, have no appreciable velocity. The radium C thus remains on the active plate. The individual properties of the separate substances can thus be studied.

An application of this method to the case of radium C has led to interesting results. Most radio-active atoms disintegrate with the emission of either α -rays or β - and γ -rays but not both. Radium C, as we have noted, gives all three types. Pure radium C can be obtained from the radio-active deposit of radium emanation by dissolving it in acid, and suspending a nickel plate in the solution. The radium C is deposited on the plate, leaving the radium B in solution. It must be remembered that each radio-active product is an element with definite chemical properties, and differs from ordinary elements only in its instability. The various products can thus be separated by the usual methods of chemical analysis. If the nickel plate bearing the radium C is placed in vacuo near a negatively charged disk recoil atoms from the radium C collect on the disk, which thus becomes radio-active. It is found, however, that the properties of the radio-active substance thus collected are quite distinct from those of the normal product of the disintegration of radium C (which is known as radium D). Thus it has a half value period of 1.38 minutes as against 16 years for radium D. This new substance which has been called radium C₂ gives out only β - and γ -rays of the same quality as those of radium C. Further, it does not give rise to radium D on disintegration.

We have here a case (the first one actually observed although others have now been recorded) in which a branch occurs in the radio-active chain. Radium C splits up in two different ways; the normal disintegration gives rise to radium D and its products in the normal line of descent, but a certain fraction of the atoms (about 1 in 6000) break up in a different way giving rise to this new product, radium C₂, the disintegration

products of which have not yet been determined. These exceptions to the usual rule are of great interest, as they may possibly throw some light on the mysterious question of the origin of radio-active change.

129. The radio-active product of slow change. As we have seen, radium C normally breaks up with the expulsion of an α -particle into a product radium D. Radium D marks a period of comparative quiescence in the radio-active decay, its half value period being about 16.5 years. Owing to its long period it is present in minute but appreciable quantities in ores containing radium from which it can be separated by the chemical processes used for the separation of lead, to which metal indeed it bears so close a resemblance that no chemical test has yet been devised for distinguishing between them. Radium D gives out neither α - nor β -rays of the ordinary type. It has, however, been shewn to give off very slow β -rays (or δ -rays) of the type given off by radium B.

The succeeding product, radium E, gives off β - and γ -rays and has a period of five days. The relation between radium D and its immediate product is thus the same as that for uranium and uranium X, and the decay and recovery curves follow the same laws. Thus in freshly prepared radium D the β -ray activity rises according to equation (106) to a maximum which owing to the slow decay of radium D remains sensibly constant for a considerable time.

Radium F, the product of the decay of radium E, emits α -rays and decays to half value in 136 days. Its rate of decay and the range of its α -particles identify it with the substance polonium, the first radio-active substance actually isolated from pitchblende. The product of the disintegration of polonium is apparently not radio-active, no trace of any radiations being observed after the α -ray activity of the polonium has disappeared. The final product of the chain has with much probability been identified with lead.

The period of radium D is too long to be determined by direct measurements. It can, however, be deduced by indirect methods which form an interesting illustration of the principles

we have been discussing. Suppose we commence with a definite quantity of emanation, say, one millicurie. The number of atoms of emanation present is then known from the determination of the curie already discussed (§ 124). Let it be N . The number of atoms of emanation breaking up per second at the beginning of the experiment is therefore $\lambda_1 N$, where λ_1 is the radio-active constant of the emanation. This will be the number of α -particles n_1 , emitted per second by the emanation present, a quantity which we can determine by the method already described (§ 98).

The emanation is then allowed to decay for a month or so at the end of which time it is practically all in the form of radium D. The number of atoms of radium D present is thus the same as the number of atoms of emanation with which we started, that is N , and the number breaking up per second is therefore $\lambda_2 N$ where λ_2 is the radio-active constant of radium D. Now radium D itself emits no α -particles. As, however, the period of radium D is long compared with that of its products E and F, the latter will be in radio-active equilibrium with it and hence the number of radium F particles breaking up per second will be the same as the number of radium D atoms disintegrating in the same time, that is $\lambda_2 N$. But this is the number n_2 of α -particles emitted per second by the mixture of radium D, E, and F in our tube, since D and E give no α -radiation. Hence

$$\frac{\lambda_2 N}{\lambda_1 N} = \frac{n_2}{n_1},$$

from which we can determine λ_2 since all the other quantities are known. The value of λ_2 is found to be 0.042 (year) $^{-1}$, corresponding to a half value period of 16.5 years.

130. The radio-activity of thorium and actinium. The element thorium is radio-active and gives rise to a chain of radio-active products in the same way as uranium gives rise to the radium chain. The disintegration process can be studied in detail by the methods already discussed, and involves no new principles. The results are sufficiently summarized in Table IX. For further details Rutherford's *Radio-active Substances and their Radiations* may be consulted.

A new element, actinium, also gives a radio-active chain of products. Both its atomic weight and its relation to the other two series, if any, are at present unknown.

TABLE VIII
Uranium-Radium series

SUBSTANCE	Radio-active constant λ in (sec.) ⁻¹	Half value period	Radiations emitted	Range of α -particles in air in cm.
Uranium 1 ...	4.3×10^{-18}	5×10^9 years	α	2.37
↙ Uranium Y	5.4×10^{-6}	1.5 days	β (slow)	—
↓ Uranium X ₁ ...	3.3×10^{-7}	24.6 days	β (slow)	—
Uranium X ₂	1.0×10^{-2}	1.15 min.	β	—
Uranium 2 ...	1×10^{-14}	2×10^6 years	α	2.75
Ionium ...	1×10^{-13}	2×10^3 years	α	2.85
Radium ...	1.26×10^{-11}	1730 years	α	3.13
Radium emanation	2.085×10^{-6}	3.85 days	α	3.94
Radium A ...	3.85×10^{-3}	3.0 min.	α	4.50
Radium B ...	4.33×10^{-4}	26.7 min.	β (slow)	—
Radium C ...	5.93×10^{-4}	19.5 min.	α, β	6.57
↘ Radium C ₂	8.3×10^{-3}	1.4 min.	β	—
Radium D ...	7.3×10^{-9}	16.5 years	β (slow)	—
Radium E ...	1.6×10^{-6}	5.0 days	β (slow)	—
Radium F ... (Polonium)	5.90×10^{-8}	136 days	α	3.58
? Lead ...	—	—	—	—

It may be noted that very careful analysis has shewn that the disintegration of uranium is considerably more complex than we have described in the previous chapter. Uranium in fact contains two radio-active substances which can be differentiated by a slight difference in range of the α -particles which they emit. There is also some evidence for a branching of the

chain at uranium resembling that already described for radium C. It is possible that actinium may be a product of one of these branches.

TABLE IX
Thorium and Actinium Series

SUBSTANCE	Radio-active constant λ in (sec.) ⁻¹	Half value period	Radiations emitted	Range of α -particles in air in cm.
Thorium ...	1.2×10^{-18}	1.8×10^{10} years	α	2.58
↓ Mesothorium 1	4.0×10^{-9}	5.5 years	—	—
↓ Mesothorium 2	3.1×10^{-5}	6.2 hours	β	—
↓ Radiothorium	1.09×10^{-8}	2.0 years	α	3.67
↓ Thorium X ...	2.20×10^{-6}	3.64 days	α	4.08
↓ Thorium emanation	1.28×10^{-2}	54 sec.	α	4.74
↓ Thorium A ...	5.0	0.14 sec.	α	5.40
↓ Thorium B ...	1.8×10^{-3}	10.6 hours	β (slow)	—
↓ Thorium C ...	1.9×10^{-4}	60 minutes	α	4.55
↙ Thorium D	3.7×10^{-3}	3.1 minutes	β	—
↓ Thorium C ₂ ...	7×10^{10}	10^{-11} sec.	α	8.16
<hr/>				
Actinium ...	—	—	—	—
↓ Radioactinium	4.1×10^{-7}	19.5 days	α	4.36
↓ Actinium X ...	7.6×10^{-7}	11.4 days	α	4.17
↓ Actinium emanation	1.8×10^{-1}	3.9 sec.	α	5.40
↓ Actinium A ...	350	.002 sec.	α	6.16
↓ Actinium B ...	3.2×10^{-4}	36.1 min.	β (slow)	—
↓ Actinium C ...	5.37×10^{-3}	2.15 min.	α	5.12
↓ Actinium D ...	2.26×10^{-3}	4.71 min.	β	—

CHAPTER XV

SOME PROBLEMS IN RADIO-ACTIVITY

131. Uranium and the origin of radium. That the origin of radium was to be found in uranium was long suspected. It is obvious that since radium decays to half value in less than 2000 years it would no longer exist on the earth at the present day unless it were being continually formed from some more stable substance. The constant association of radium with uranium ores and the radio-activity of the latter element naturally led to the supposition that radium was formed by the disintegration of the uranium atom.

The observed constancy of the ratio of the radium to the uranium in uranium ores of very varied composition strongly supported this assumption. The constancy of the ratio is, indeed, very remarkable, the only exceptions being in the case of minerals which are known from geological evidence to have been comparatively recent deposits (in which case radio-active equilibrium will not have been established) or to have been subjected to the action of water or other disintegrating circumstances.

While this proves that radium is a member of the uranium disintegration series it does not follow that it is the direct product of the decomposition of uranium X. In fact it is quite easy to shew that this is not the case. The transformation constant of uranium is 4.3×10^{-18} secs. or 1.4×10^{-10} years. As an atom of uranium of atomic weight 238 produces one of radium with an atomic weight 226, the total weight of radium formed in one year from a kilogram of pure uranium should, if the uranium changes directly into radium, be

$$1000 \times (1.4 \times 10^{-10}) \times 226/238$$

or 1.3×10^{-7} gm. This could be detected with ease. In fact even one-thousandth part of this could be detected with some certainty. On making the experiments it was found that com-

mencing with pure uranium (free from all its radio-active products) the rate of production of radium was certainly less than one-thousandth part of what would be expected if uranium X changed directly into radium. There must therefore be some product of long period intermediate between these two members of the chain.

Two intermediate substances have now been isolated. One is known as ionium. It has a period which is estimated at about 2×10^3 years, and gives off α -particles of comparatively small range. It is chemically similar to thorium, but differs from it in the range of the α -particles and in its radio-active constant. The production of radium in solutions of ionium has been observed. The other is known as Uranium 2, and has a period of 2×10^6 years.

132. Production of helium from uranium. Geological age. Since each α -particle is an atom of helium, helium must be in process of formation in all minerals containing uranium. The number of α -particles given out by one gram of uranium in equilibrium with all its products has been found to be 9.7×10^4 per second. The number of atoms of helium formed per annum by one gram of uranium is thus

$$(9.7 \times 10^4) \times 60 \times 60 \times 24 \times 365$$

or taking Avogadro's constant as 2.7×10^{19} molecules per c.c., about 11×10^{-5} cubic mm. The direct measurement of the rate at which helium is produced in uranium ores is in fair agreement with this estimate.

Thus if we can assume that the helium produced is all occluded by the mineral, the ratio of the helium to the uranium present affords us a method of estimating the age of the mineral. The results are found to be qualitatively consistent with the ages suggested by geological considerations, that is to say, the rocks of older formations give a higher ratio of helium to uranium than those of more recent formation. Strutt, to whom most of our information is due, estimates the age of the oligocene rocks as eight million years, and the ages of the eocene, carboniferous, and archæan periods as respectively 31, 150 and 700 million years. Since there is always the possi-

bility of a certain loss of helium from the rocks by diffusion into the air, these are obviously minimum estimates.

133. The end-product of the uranium chain. Polonium is the last radio-active member of the uranium-radium series. After the decay of the polonium no residual activity of any kind has been discovered. As we have seen the atomic weight of the final product should be about 206, approximately that of lead (207). If this is so, there should be some definite constant ratio between the amount of lead present in a uranium ore and the quantity of helium also present. For the formation of one atom of lead by the disintegration of an atom of uranium is attended with the emission of eight atoms of helium each of atomic weight 4. Hence the mass of lead present should be $207/(8 \times 4)$ or 6.5 times that of the helium present supposing both to be formed by the disintegration of uranium.

The observed ratios vary considerably in different minerals. This is to be expected since in the first place helium may escape through diffusion from the mineral, while in the second place lead may have been originally present in the mineral apart from its uranium constant, as lead is a somewhat widely diffused element. In general the ratio of lead to helium is about twice the calculated value. Under the circumstances the agreement is sufficiently satisfactory, and the production of lead by the disintegration of uranium may be regarded as reasonably certain.

The ratio of lead to uranium may therefore be used as a criterion of the age of the minerals. This will obviously give a maximum estimate. In this way the age of the carboniferous rocks has been calculated as about 340 million years, and of the archæan rocks as about 1300 million years. Their true age probably lies between these values and those given by Strutt from a study of the helium content.

134. The heating effect of radium. Since the various radiations from radio-active substances are emitted with very high velocities it is evident that a radio-active substance is giving out energy at a very appreciable rate. If it is surrounded by sufficient material to absorb all the radiations this energy will manifest itself eventually in the form of heat. Thus radium,

for example, is constantly producing heat and will maintain itself at an appreciably higher temperature than its surroundings.

Owing to their relatively large mass the bulk of the energy is carried by the α -rays. The percentage of energy carried by the β - and γ -rays is somewhat difficult to estimate exactly but is certainly small. The total number of ions formed in air by the complete absorption of the β -rays from a gram of radium is estimated at 9×10^{14} , and by the γ -rays at 13×10^{14} . The number of ions produced by the α -rays from the same source is 2.56×10^{16} . If we assume that these numbers are approximately proportional to the energy in the rays, these results shew that about 8 per cent. of the energy is associated with the β - and γ -radiations.

The heating effect of the α -rays can be calculated from their known velocities. Let n be the number of α -particles of velocity v emitted per second by each of the α -ray products present; n will be the same for each if equilibrium is established. The total energy of the α -rays is thus $\frac{1}{2}m \sum n v^2$ where m is the mass of an α -particle. To this we must add the energy of recoil of the various recoil atoms which as we have seen is m/M of that of the corresponding α -particle, where M is the mass of the recoil atom. Thus the total energy associated with the α -radiation, is

$$\frac{1}{2} m n \Sigma \left(1 + \frac{m}{M} \right) v^2.$$

In the case of radium in equilibrium with its short period products this is equal to 1.38×10^6 ergs per second, or about 118 gram calories per hour. If only the α -rays are absorbed in the apparatus this should be the rate of emission of heat by one gram of radium in equilibrium with its short lived products. If the radium has been prepared for several years so that an appreciable amount of polonium is present the heating effect of this must be added. If the apparatus, as is usually the case, absorbs an appreciable percentage of the β - and γ -rays the heating effect will be somewhat greater; if all the rays are absorbed it should be about 128 calories per hour.

The effect is thus quite measurable. The most sensitive form of apparatus for this purpose is that designed by Duane, following a suggestion of Callender's. It is shewn in Fig. 95.

The radio-active compound is placed in the bulb *A* of a sort of differential vapour pressure thermometer, which is connected to a second similar bulb *B*. Both bulbs contain a volatile liquid (ether, for example) but are carefully freed from air. A short liquid index *X* in the connecting tube shews the equality of pressure in the two bulbs.

Owing to the emission of heat by the compound in *A* the temperature in *A* would rise and thus the vapour pressure increase. As the vapour pressure of ether increases rapidly with temperature the instrument is very sensitive to tempera-

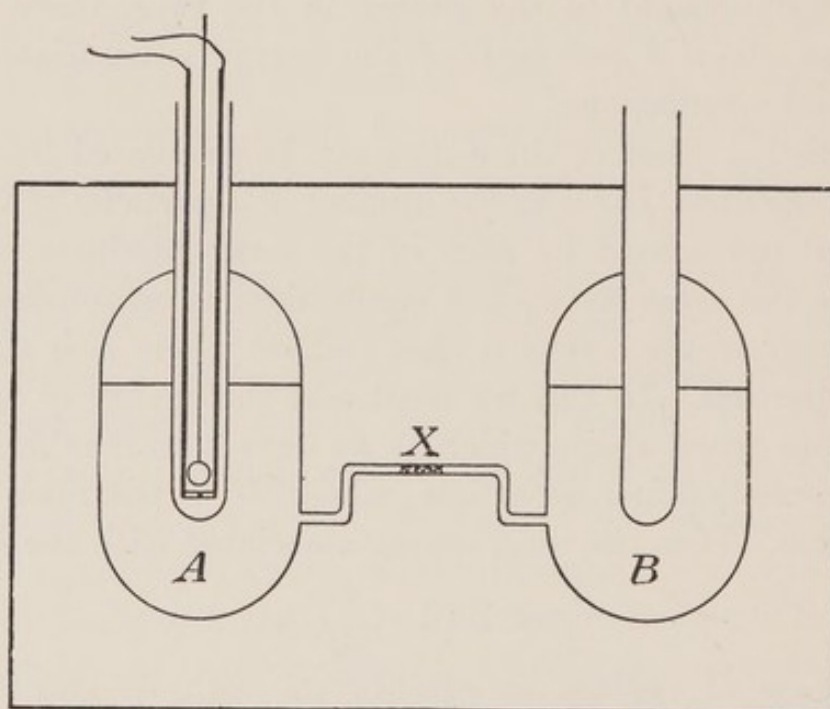

Fig. 95

ture changes. The heating effect is, however, counteracted by passing a current in the proper direction through a junction of bismuth and antimony. This produces an absorption of heat (Peltier effect) which is proportional to the current and is known if the coefficient of the Peltier effect for the two metals is known. By adjusting the current until the index remains stationary, the emission of heat by the compound is equal to the absorption of heat by the junction and is thus known if the current is measured. An emission of heat of $\cdot 0002$ calorie per second can be detected with certainty. The values obtained in this way vary between 120 and 132 calories per second, figures which agree sufficiently closely with the calculated values.

It has been found, using an apparatus of this sort, that in the case of such a substance as radium emanation the rate of emission of heat decays at the same rate as the substance itself. We can thus calculate the total heat emitted by a radio-active substance during its life. Taking the case of radium emanation, for example, it is found that one curie of emanation gives out 109 calories per hour. The mass of one curie is 6×10^{-6} gm., and hence the rate of emission of heat by the emanation is 1.82×10^7 calories per hour per gm. But since the rate of emission decreases with the decay of the emanation we have

$$H = H_0 e^{-\lambda t}$$

where H is the rate of emission at the instant t . Thus the total heat emitted by the emanation is

$$\int_0^{\infty} H_0 e^{-\lambda t} dt = H_0 / \lambda.$$

Now λ , the radio-active constant of the emanation, is 2.085×10^{-6} per sec. or .0075 per hour, and H_0 has just been obtained. Hence the total heat emitted by a gram of emanation would be no less than $1.82 \times 10^7 / .0075$, or 2.44×10^9 calories.

The formation of one gram of water is attended with the liberation of about 3.8×10^3 calories of heat. This is the most energetic reaction known to chemists. It will be seen therefore that the heat liberated in any chemical reaction is infinitesimal compared with that produced by radio-active changes.

The change also differs from chemical action in the fact that it is independent of temperature. If a quantity of radium enclosed in a tube is lowered into liquid hydrogen, the rate of heat emission can be calculated by measuring the rate at which the liquid hydrogen is evaporated, the latent heat of liquid hydrogen being known. The experiment was performed by Curie and Dewar, and gave results comparable with the values obtained by other methods at ordinary temperatures. Thus even at the temperature of liquid hydrogen, a temperature at which even the most active chemical changes cease, the rate of emission of heat by the radio-active substance remains unaltered.

This energy must be derived from the internal energy of the atoms themselves. Since the radio-active elements differ in no

way from non-active elements except for their instability the amount of intra-atomic energy must be very large. Thus the emanation gives out 2.44×10^9 calories in changing from an atomic weight of 222 to one of 210 with the emission of three helium atoms. As the final product and the helium atoms presumably also contain amounts of energy comparable with that of the emanation atom, the total energy in the atom must be exceedingly large.

135. The range of the α -particles and the period of decay. A very interesting relation has been discovered by Geiger between the range of the α -particles emitted by a radioactive substance and its coefficient of transformation. If the logarithm of the transformation constant is plotted against the logarithm of the range of the α -particles emitted, the points for all the disintegration products of the uranium chain are found to lie on a single straight line. The shorter the transformation product the greater the range. Thus the more unstable the atom the greater the velocity of the α -radiation. A similar relation holds for the members of the thorium series. The straight line in this case is parallel to that of the uranium chain but is displaced slightly, the α -particles from the thorium series being ejected with rather higher velocities than those from products of similar period in the uranium chain.

This important result has not yet found an explanation. It suggests that the chance of an atom disintegrating increases with the amount of energy which it can give out in forming the next member of the series. This seems not improbable on general grounds.

136. Radio-activity of ordinary matter. The instances of radio-active change which we have considered naturally provoked the question as to whether all elements might not be radio-active to some extent. It was pointed out that every physical property as yet discovered in one element was possessed to a greater or smaller degree by all other elements. Magnetism, for example, provided an instance very much to the point. As tested by rough experiments only iron, cobalt, and nickel

possessed magnetic properties to a noticeable degree. On making careful examination by powerful methods it was, however, found that all substances had some magnetic properties, being either para- or dia-magnetic.

The experiments were most conveniently carried out using an electroscope of the form shewn in Fig. 1. By lining the walls with sheets of the various substances under investigation, the amount of ionization produced in the presence of these different substances could be determined. It was found, as we have already mentioned, that there was always a certain amount of ionization in the gas of the electroscope, even in the absence of any recognized radio-active substance. The amount of this ionization was found to depend on the nature of the lining. This suggested that the source of the ionization was some form of radiation proceeding from the lining of the vessel. Campbell, after an exhaustive series of experiments, came to the conclusion that all substances shewed feeble radio-active properties, emitting rays which were characteristic of the metal.

The matter is an exceedingly difficult one to elucidate. Radium in very minute quantities is exceedingly widely distributed. Most soils contain an appreciable quantity, and most natural waters can be shewn to be feebly radio-active from the dissolved salts of radium which they contain. As radium emanation is a gas at ordinary temperatures it is always present in the air, in amounts which can be measured by suitable means, and which vary from day to day in a somewhat inexplicable manner.

The gas in the vessel is thus subjected to the ionizing influence of the γ -rays from the radium in the soil and its disintegration products in the atmosphere. This can be partly screened off by the use of lead blocks of considerable thickness. By finding how the ionization in the vessel decreases with the thickness of the screen, the residual ionization not due to these radiations can be calculated. A much better plan has been used by McClennan, who found that the waters of Lake Ontario were sufficiently deep to cut off the whole of the γ -radiation from the earth below them, while they themselves did not contain sufficient radio-active matter to cause any appreciable ionization

in the electroscope. By making experiments over the lake he found that the number of ions formed per second per cubic centimetre of gas was reduced to 4.8 when the electroscope was of aluminium and 6.3 when it was of brass. The difference in the two values suggests that the small residual effect is due to the metal of the electroscope.

The effect is however so minute that it is difficult to decide with certainty. A single α -particle from radium produces more than 10^5 ions during its path of 3 cms. The passage of a single α -particle through each cubic centimetre of the gas, once every three hours, would therefore be sufficient to produce the average ionization found under these circumstances. The quantity of radio-active impurity in the metal necessary to produce an emission of this order is so minute that it is difficult to prove conclusively that the effect is not due to this cause, and Rutherford after a careful survey of the results has come to the conclusion that ordinary matter is not radio-active. On the other hand experimenters who have actually worked on the subject generally incline to the view that there is a residual effect due to the actual radio-activity of the elements themselves.

The survey of the subject has, however, led to the discovery of one more radio-active substance, namely potassium, which is found to emit β -radiation of very much the same type as that from uranium. The activity of a surface of potassium salt is quite appreciable, being in general about one per cent. of that of a surface of a salt of uranium. Rubidium has also been found to possess a similar radio-activity. In neither case is anything yet known as to the nature of the product, or the period of the change.

CHAPTER XVI

THE ELECTRON THEORY OF MATTER

137. **The constitution of the atom.** The researches chronicled in the preceding chapters have thrown considerable light on the obscure subject of the nature of matter and the constitution of the atom. Let us recapitulate, briefly, the information which has actually been obtained on this important subject.

In the first case we have seen that matter of all kinds is capable of emitting electrons when subjected to suitable ionizing agents. Thus electrons are emitted from all kinds of matter under the influence of X-rays, or of ultra-violet light of suitable wave length. They are produced by the impact of the α - and β -rays from radio-active substances, or by that of the charged gaseous ions. They are present in large numbers in the discharge tube, and may even be produced from any metal, merely by raising its temperature to a sufficiently high value. They are, therefore, present in all kinds of matter, and thus presumably form an integral part of the atom of every element.

The number of electrons present in a given atom has been estimated in various ways, for example from the intensity of the scattered X-radiation (§ 84) and from the scattering of the β -particles (§ 108). The results obtained by different methods agree fairly well and, though more precise experiments are desirable, indicate clearly that the number is certainly less than the atomic weight, and is approximately equal to one-half the atomic weight. We have noted (§ 90) that the relationships detected between the X-ray spectra become more exact if we substitute for the atomic weight of the element its atomic number, that is to say, its number in the list of the elements arranged in order of ascending atomic weights. The atomic number is, except in the case of hydrogen, approximately

equal to one-half its atomic weight. It is probable, therefore, that the atomic number is more fundamental than the atomic weight, and that the slight variations observed between the atomic number and one-half the atomic weight are due to secondary causes. Van der Broek has suggested that the number of electrons in an atom is equal to its atomic number. This suggestion is at any rate very probable.

We have seen that the electrons emitted from different substances and by different ionizing agents are identical, except in velocity. Each electron carries a negative charge of 4.7×10^{-10} e.s.u., has a radius of the order of 10^{-13} cm. (assuming it to be spherical) and a mass of about 9×10^{-28} gm. Further, the mass of the electron has been shewn (§ 105) to be entirely due to the charge upon it. The mass of the electron is an insignificant part of the mass of the whole atom (about 1/1800 in the case of hydrogen) and its volume an infinitesimal fraction of the volume of the atom.

Since the atom as a whole is neutral (except when ionized by the emission of an electron) it must contain a positive charge of magnitude ne , where e is the electronic charge and n is the number of electrons in the atom. On Van der Broek's hypothesis n will be equal to the atomic number, a result which is confirmed by experiments on the scattering of the α -particles by matter (§ 102).

The fact that the α -particles, which as we have seen are atoms of helium, are able to penetrate appreciable thicknesses of solid material effectively disposes of the hard or "solid" atom theory. It is evident that these results can only be explained on the assumption that the atoms are capable of inter-penetration to a very considerable extent. The modern view is that the atom consists merely of electrons and positive electricity. While this may not be definitely established we may affirm that none of our experiments have given any indication of the presence of anything besides.

Assuming, then, that an atom consists of electrons together with a corresponding positive charge it is easy to shew that the latter must occupy a space of very small dimensions. The experiments on the projection of hydrogen atoms by the impact

of α -particles (§ 102) shew that the former is projected with a velocity about 1.6 times that of the α -particle. Assuming that the force is due to the mutual repulsion of the positive charges on the two particles it can be shewn that the centres of the two charges must approach to within 1.7×10^{-13} cm. and that they behave as point charges at least up to this distance. In other words the positive charge on the hydrogen atom is confined to a nucleus the radius of which is certainly less than 10^{-13} cm., that is, less than that of the negative electron.

The positive charge is never found associated with a mass less than that of an atom. Thus the α -particles are atoms of helium carrying a charge $2e$, while all the positive particles in a discharge tube (§ 54) have masses equal to those of the atoms and molecules in the tube. In no case has a positive charge been found associated with any particle of smaller mass than the hydrogen atom. As the negative electrons form but an insignificant fraction of the mass of the atom it is clear that this mass must be associated with the positive charge, and so far all experiments have failed to obtain the positive charge dissociated from this mass. It seems a reasonable inference that mass is a property of the positive charge.

We have seen that a particle carrying a charge e has an electromagnetic mass due to its charge and equal to $\frac{2}{3} \frac{e^2}{a}$ where a is the radius. This result has been confirmed in the case of the negative electrons. It is clear from the formula that the electromagnetic mass is inversely proportional to the radius of the particle on which the electricity is concentrated. Thus if the positive nucleus carries the same charge, e , as an electron, its mass will be equal to that of a hydrogen atom if we assume it to be concentrated on a sphere of radius $1/1800$ of that of the electron. The fact that the radius of the positive nucleus is at any rate less than that of an electron, certainly lends weight to the assumption. It would seem probable, therefore, that all mass is electromagnetic, and that a hydrogen atom consists solely of a positive charge concentrated on a nucleus of very small dimensions, and a single attendant negative electron.

138. **Arrangement of electrons in an atom.** If we accept these conclusions, the atom of an element of low atomic weight is a comparatively simple structure. Thus the hydrogen atom would consist of a single positive nucleus, and one electron; the helium atom would have a nucleus bearing a double positive charge, with two electrons, and so on, each element differing from the one preceding it, in containing one additional charge on its nucleus, and one additional electron. It would seem at first sight that the arrangement and therefore the properties of these systems should be easily calculable. This, however, is far from being the case. Numerous mathematical physicists have attacked the problem, including Schott, Thomson, Nicholson, and Böhr, but none of the results obtained so far have been at all decisive. The attempts of Böhr have been on the whole the most successful, but as his assumptions involve not only the abandonment of the ordinary Newtonian mechanics, but also very extensive changes in the generally accepted electromagnetic theory, they cannot be regarded as certain, nor indeed at present as having found their final form.

The different theories, however, seem to have reached agreement on certain important points. In the first place the electrons must arrange themselves in certain definite rings within the atom. In the second place a ring system of electrons consisting of a given number of electrons will in general only be stable if it contains within its boundaries a certain minimum number of other electrons. The atomic system then in all probability consists of a number of concentric rings of electrons grouped around a positively charged central nucleus, and thus forms a system something like that of the planet Saturn on an infinitesimal scale.

Sir J. J. Thomson has obtained a complete solution of the problem on the assumptions that the positive electricity is uniformly distributed throughout a sphere of atomic radius, and that further the rings of electrons are confined to a single plane. The former assumption is almost certainly not valid, and the actual numbers have, therefore, no special significance. They will, however, serve to illustrate the nature and effect of the laws of electron grouping stated above.

For any number of electrons up to five, it was found that they could arrange themselves in a single ring. A ring of six electrons was, however, unstable, and broke up into an outer ring of five, with a single electron in the middle. The ring of six could, however, be made stable by placing a single electron within it, and rings of seven and eight were also stable under the same conditions. An outer ring of nine, however, required three electrons to make it stable, and an outer ring of 16 no less than twenty. For large values of the number n in the outer ring the number p required inside it to ensure stability varies approximately as n^3 . These inner electrons will arrange themselves according to the same laws as the others and will thus break up into a series of ring systems as indicated in the following table.

A Outer ring	1	2	3	4	5														
B Outer ring	5	6	7	8	8	8	9	10	10	10	11								
Inner ring	1	1	1	1	2	3	3	3	4	5	5								
C Outer ring	11	11	11	12	12	12	13	13	13	13	14	14	15	15					
2nd ring	5	6	7	7	8	8	8	9	10	10	10	10	10	11					
1st ring	1	1	1	1	2	3	3	3	3	4	4	5	5	5					
D Outer ring	15	15	15	16	16	16	16	16	16	16	17	17	17	17	17	17	17		
3rd ring	11	11	11	11	12	12	12	12	12	13	13	13	13	13	14	14	15	15	
2nd ring	5	6	7	7	7	7	8	8	8	8	9	9	10	10	10	10	10	11	
1st ring	1	1	1	1	1	1	1	2	3	3	3	3	3	4	4	5	5	5	
											<i>a</i>	<i>b</i>	<i>c</i>	<i>d</i>	<i>e</i>	<i>f</i>	<i>g</i>		
E Outer ring	17	18	18	18															
4th ring	15	15	15	15															
3rd ring	11	11	11	11			etc.												
2nd ring	5	5	6	7															
1st ring	1	1	1	1															
	<i>h</i>	<i>i</i>																	

The results are very suggestive. In the first place it will be noted that a given grouping of electrons recurs again and again in the table. Thus the grouping 11, 5, 1, which commences series C, recurs again at the beginning of D with an extra ring of 15, and at the beginning of E with a further additional ring of 17. We should expect that systems with the same internal structure would exhibit very similar properties. If this is the case we should also expect that these systems should

be separated by others having increasingly divergent properties. This is exactly what is found when the actual elements are arranged in order of their ascending atomic weights, elements such as lithium, sodium, potassium, etc., having very similar properties recurring from point to point in the table, while they are separated by other elements differing increasingly widely in character from them. Some such arrangement as is actually to be found in Mendeleef's periodic law is therefore a necessary consequence of the laws of electron grouping.

139. **Chemical properties of the elements a result of electron grouping.** The analogy between these systems of electrons and the periodic classification can be brought out still more clearly if we consider the equilibrium of a number of consecutive systems ($a-h$) in the table, p. 257, having the same number of electrons in the outer ring, say, for example, those with seventeen. The first of these systems a is the first "element" with an outer ring of 17 and has only just sufficient inner electrons to render this outer ring possible. It is, therefore, only just stable and will require therefore only a small force to displace an electron from it, leaving an outer ring of 16. But the system 16, 13, 9, 3 is exceedingly stable as it contains nine electrons over and above the number required to make its outer ring stable. It would, therefore, be very unlikely to give up any further electrons, especially when it contains a positive charge owing to the emission of an electron. The system a would therefore very readily part with one, but only one electron. It would thus behave as a monovalent electro-positive element, such as sodium. The system b containing one more electron is naturally somewhat more stable, and will not part with its electrons under such small forces as are sufficient for a . It can, however, part with two of them before reaching the stable state. It is therefore divalent, but not quite so electro-positive as the element a . Its properties therefore correspond with those of, say, the element magnesium. Similarly c would be trivalent, but less electro-positive than either of its predecessors, corresponding thus to aluminium, and so on.

Coming now to the other end of the series, the element h

should theoretically be able to emit eight electrons. Its system is an exceedingly stable one, and the force required to remove an electron would thus be very large, probably too large to be exerted by the action of another atom upon it, so that it is unlikely that this valency would be increased. Again it will not be able to absorb an electron into its system, and thus acquire a negative valency, for if it did so it would have to form an outer ring of 18. As this system even when neutral is very unstable it would obviously be even more so if negatively charged. The atom *h* is therefore incapable of shewing either a positive or a negative valency. It thus corresponds to one of the inert gases, such as argon for example. On the other hand, the preceding element in the series *h* will obviously tend to acquire an extra electron since this would increase its stability. It could not, however, acquire more than one, for as the preceding argument shows, this would lead to complete instability. It would, therefore, behave as a monovalent electro-negative element, corresponding thus to chlorine. Similarly *g* would have a negative valency of two and so on. The results for this series of elements are summarized in the following table.

	<i>a</i>	<i>b</i>	<i>c</i>	<i>d</i>	<i>e</i>	<i>f</i>	<i>g</i>	<i>h</i>
Total number of electrons	42	43	44	45	46	47	48	49
Positive valency	1	2	3	4	5	6	7	(8)
Negative valency	7	6	5	4	3	2	1	0
Element	Na	Mg	Al	Si	P	S	Cl	A
Atomic number	11	12	13	14	15	16	17	18
Positive valency	1	2	3	4	5	6	7	0
Negative valency	7	6	5	4	3	2	1	0

The corresponding properties of the elements from sodium to argon are placed below for comparison.

The numbers are illustrative only. As we have seen, the actual number of electrons in the various rings has yet to be determined. It suffices, however, to illustrate the fact that some such arrangement as the periodic table is a natural result of the electron theory of the structure of the atom.

140. **The nature of the nucleus. Radio-activity.** The positive nucleus of the hydrogen atom is probably a single positive charge, or positive electron, as we may call it. It is probable, however, that the nuclei of the elements of higher atomic weight are complex and also contain negative as well as positive electrons. The helium atom, for example, which has an atomic number two, should have a nuclear charge $2e$. Its mass is, however, four times that of the hydrogen atom, so that, assuming the positive electrons to be all of the same kind, it would require four of them to produce the required mass. The simplest assumption we can make is that the helium nucleus contains four positive electrons together with two negative electrons, which would produce a resultant positive charge of the right size.

The presence of negative electrons in the nucleus itself seems required by the phenomena of radio-activity. The β -rays are ejected from radio-active substances with enormous velocities, approaching within two per cent. of that of light. These velocities could hardly be produced by the comparatively weak forces between the nucleus and its external electrons. They might easily be produced by the very intense forces set up when such a comparatively large number of charges are contained within such a small volume as that of the nucleus of a radium atom. The energy of the α -particles would be due to the same cause. The fact that the ejected α -particle seems to be invariably an atom of helium would suggest that the helium nucleus is present as such in the nuclei of elements of higher atomic weight. We have at present, however, no means of investigating these points.

The actual cause of radio-active disintegration is not yet known. It is easy to shew on general principles that the conditions requisite for the equilibrium of a number of discrete charges become more difficult to fulfil as the number is increased. It may be noted that all the elements of atomic weight greater than 208 are radio-active and that no element of higher atomic weight than 238.5 is known. This point seems therefore to be the upper limit of possibility for the existence of structures such as we have been describing.

141. Emission of light. The Zeeman effect. It is generally recognized that light is transmitted by wave motion and is, therefore, due to the vibrations of systems in the substance emitting the light. On the electromagnetic theory of light, the disturbances are electromagnetic waves. They thus differ from X-rays only in wave length and in the fact that instead of being discontinuous pulses they form trains of disturbances containing a considerable number of wave lengths. We have seen (§ 81) that an electron when accelerated gives out radiation at a rate equal to $\frac{2}{3} \frac{e^2 f^2}{c}$ where f is the acceleration and c the velocity of light. An electron executing harmonic vibrations of any kind would therefore radiate energy, the period of the radiation being equal to that of the electron. It is natural to suppose that these radiations constitute light.

The matter can fortunately be put to the proof. If a source of light, say, for example, a sodium flame, be placed between the poles of a strong electro-magnet, and the light emitted be analysed by a powerful interference spectrometer, it is found that the spectral lines emitted by the source are split up into two or more components. If the lines are observed in a direction at right angles to the magnetic field, the original line is seen to be accompanied by two other lines, one on each side of it, and separated from it, in the case of very strong fields, by a distance which may amount to as much as one-fifth of the distance separating the two sodium lines. If the light is viewed in a direction parallel to the lines of the field, the centre line disappears, and the two outer components are seen alone. This is known as the Zeeman effect. The two outer components are circularly polarized in opposite directions, when viewed along the lines of the field.

The explanation of the Zeeman effect has been given by Lorentz. Since the systems emitting the light are influenced by a magnetic field they must obviously be charged. Let e be the charge and m the mass of one of these vibrating systems. Assuming that the vibrations are simple harmonic they may be resolved into components perpendicular and parallel to the magnetic field. The vibrations parallel to the field will be

unaffected by the field since a magnetic field has no effect on a charged particle moving parallel to the lines of force. The component at right angles to the field may be regarded for convenience as equivalent to two equal and opposite circular rotations, executed in the same period, but in opposite directions. In other words we may regard the particles as describing circular orbits of equal radius, and in equal times, but in opposite directions.

Let f be the retaining force in the absence of the field. Then since the motion is simple harmonic

$$f = kr$$

where r is the radius and k a constant. Also by the ordinary mechanical laws

$$f = \frac{mv^2}{r}.$$

If T is the time of vibration, $v = \frac{2\pi r}{T}$;

$$\therefore k = \frac{4\pi^2 m}{T^2}.$$

The field H produces a force on the particle equal to Hev which since it is at right angles to the field and to the direction of motion of the particle must always act along the radius. Since the two orbits are described in opposite directions it will in one case be directed outwards, in the other inwards, along the radius. The direction of the force depends on the direction of rotation and the sign of the charge and can be determined by the usual rule when these are known. Thus, when the field is applied we have

$$\left. \begin{aligned} \frac{mv_1^2}{r_1} &= kr_1 - Hev_1 \text{ for the clockwise rotation} \\ \frac{mv_2^2}{r_2} &= kr_2 + Hev_2 \text{ for the counter-clockwise rotation} \end{aligned} \right\}, \quad (118)$$

where e is supposed to carry its own sign. Substituting in these equations for k and for the velocities, we have

$$\begin{aligned} \frac{4\pi^2 m}{T_1^2} &= \frac{4\pi^2 m}{T^2} - He \frac{2\pi}{T_1}, \\ \frac{4\pi^2 m}{T_2^2} &= \frac{4\pi^2 m}{T^2} + He \frac{2\pi}{T_2}, \end{aligned}$$

or on subtracting

$$4\pi^2 m \left\{ \frac{1}{T_1^2} - \frac{1}{T_2^2} \right\} = -2\pi H e \left\{ \frac{1}{T_1} + \frac{1}{T_2} \right\}$$

$$\frac{e}{m} = \frac{2\pi}{H} \frac{T_1 - T_2}{T_1 T_2} = \frac{2\pi}{H} \frac{T_1 - T_2}{T_0^2} \quad \dots \quad (119)$$

writing T_0 for $T_1 T_2$ which is permissible since the change produced in the periods is very small. But if λ is the wave length of the light emitted $\lambda = cT$ where c is the velocity of light. Hence finally if λ_0 is the original wave length, λ_c that of the clockwise disturbance, λ_a that of the counter-clockwise rotation

$$\frac{e}{m} = \frac{2\pi c}{H} \frac{\lambda_c - \lambda_a}{\lambda_0^2} \quad \dots \quad (120)$$

Thus if the particles carry a positive charge so that e is positive the component of greater wave length will be circularly polarized in a clockwise direction; if negative it will be polarized in a counter-clockwise direction, as viewed along the positive direction of the lines of the magnetic field. The latter is found experimentally to be the case. Hence the particles emitting the light are negatively charged.

The component of the vibration parallel to the field will produce no radiation in this direction, as a charged system gives no radiation along the line of its motion (§ 74). If viewed at right angles to the field this component will give a line in the undisplaced position of the original line which will be plane polarized, the direction of the electric displacement being parallel to the field. The two displaced lines will be plane polarized in a plane at right angles to this, since from this direction their orbits are viewed end on. These predictions are verified by experiments.

Runge and Paschen found that for a certain series of mercury lines the value of $\frac{\lambda_c - \lambda_a}{\lambda_0^2}$ was -2.14 for a magnetic field of 24,600 gauss. Substituting these values in the equation (120), we have

$$\frac{e}{m} = \frac{2.14 \times 2\pi \times (3 \times 10^{10})}{24,600} = 1.65 \times 10^7.$$

This value agrees closely with the value of the same ratio for a negative electron. The systems emitting the lines in the spectra are therefore electrons.

The Zeeman effect is often more complex than we have described it, some lines breaking up into as many as thirteen components. A more complete analysis on lines similar to the above but taking into account the fact that the vibrations of the electron are not necessarily simple harmonic, has enabled Lorentz to explain these more complex phenomena successfully.

There is one difficulty which immediately arises. A hydrogen atom, as we have seen, probably contains only a single electron. This will at most have three possible periods of vibration, which if the atom is symmetrical will all have the same period. It should therefore emit only one spectral line. As a matter of fact its spectrum shews a considerable number. It is evident, therefore, that the lines of the hydrogen spectrum cannot be emitted by the hydrogen atom itself. This result is indeed fully borne out by the phenomenon of the dispersion of light in hydrogen which is consistent with the assumption that hydrogen possesses one absorption line situated far in the ultra-violet. As is well known any system shews very marked absorption for radiations corresponding to its own free period, the effect being well shewn by the Fraunhofer lines in the solar spectrum and by the well-known reversal of the sodium lines by passage through sodium vapour. Hydrogen shews no selective absorption for the lines of the hydrogen spectrum.

It has been pointed out that a substance only emits its characteristic spectrum when it is subjected to intense ionization. Thus we have seen (§ 41) that the luminous parts of a discharge tube are exactly those parts where the ionization is most intense. Similarly we have seen (§ 68) that a flame, especially when containing salt vapours, is the seat of intense ionization. Thus it is only when the substance is ionized that light is emitted. It is interesting to note that Ladenburg obtained evidence of selective absorption of the hydrogen lines when the light from a very bright discharge in hydrogen was passed through a long discharge tube containing hydrogen which was kept feebly glowing by a much weaker discharge. It would seem a fair inference that the light emitting systems are only brought into existence when the atom has lost an electron.

It seems probable that an electron on recombining with an ionized atom does not fall immediately into the atom, but owing to its velocity describes a series of orbits round it, in the same way that the planets describe orbits round the sun. Each of these orbits will be described in a definite period, and will give rise to a single line in the spectrum. A single electron in passing successively through each of these orbits will thus emit in succession each of the lines in the spectrum. If the process was one of gradual collapse, so that the electron described circles of gradually diminishing radius, the light emitted would of course contain vibrations of every possible period, that is to say, it would be white light. It can, however, be shewn that the number of orbits in which it is possible for the electron to move with the periodic motion necessary for the production of light is not infinite, but that their number and radius depend on the arrangement of the electrons in the atom. They are thus as characteristic of the atom as the periods of its own electrons, while at the same time the light of corresponding frequency is only emitted when the atom is undergoing recombination. Böhr on the assumption that the difference in the energy of the electrons describing two successive orbits is equal to the "quantum of energy" (§ 73) has succeeded in accounting numerically for some of the lines in the hydrogen spectrum.

142. Electron theory of metallic conduction. The phenomenon of the conduction of metals for electricity, at any rate as far as its main outlines are concerned, presents no difficulties on the electron theory. We have seen (§ 62) that a metal contains free electrons which are capable of moving about through it, and behave very much as the molecules of an ordinary gas. The actual cause of emission of these electrons is perhaps not altogether clear, but all metals are electro-positive, that is to say, they are substances the atoms of which readily emit electrons. The atmosphere of electrons is in equilibrium with the atoms, and the number per unit volume is thus kept constant by a process analogous to that of evaporation. We may regard the pressure of the electrons in the metal

as analogous to that of a saturated vapour in contact with its own liquid.

We have seen (§ 62) that these electrons partake of the energy of thermal agitation of the surrounding atoms, and may be treated by the ordinary principles of the kinetic theory of gases. The velocity v of thermal agitation is, therefore, given by

$$\frac{1}{2}mv^2 = \alpha\theta \quad . \quad . \quad . \quad . \quad . \quad . \quad (121)$$

where α is a constant which is the same for all gases, and θ is the absolute temperature. The velocity can thus be determined, for if m_h and v_h are the mass and velocity of the hydrogen molecule we have

$$\frac{1}{2}mv^2 = \alpha\theta = \frac{1}{2}m_h v_h^2,$$

$$\therefore v^2 = \frac{m_h}{m} v_h^2.$$

But the velocity of a hydrogen molecule in a gas at 0° C. is 1.842×10^5 cm./sec. Hence

$$v^2 = 2 \times 1840 (1.84 \times 10^5)^2,$$

$$v = 11 \times 10^6 \text{ cm. per sec.},$$

since the mass of an electron is about $1/1840$ that of a hydrogen atom.

These velocities are equally distributed in all directions and thus cause no transference of electricity through the conductor. If, however, an electric field X is applied it will cause a steady drift of the electrons in the opposite direction to the field, since the electrons are negatively charged. The positive atoms being fixed do not move under the field and therefore add nothing to the current. Thus if n is the number of electrons per unit volume, the current across any cross section of the conductor of area A is given (5) by

$$i = AnekX$$

where k is the mobility of the electron. The mobility of the electron can be calculated in exactly the same way as the mobility of a charged ion in a gas and is therefore (12) given

by $\frac{1}{2} \frac{e \lambda}{m v}$ or substituting for m from (121) by $\frac{e \lambda v}{4 \alpha \theta}$. Thus

$$i = A \frac{ne^2 \lambda}{2mv} X = A \frac{ne^2 \lambda v}{4 \alpha \theta} X. \quad . \quad . \quad . \quad (122)$$

If the field is uniform we have $X = \frac{E}{d}$, where d is the length of the conductor and E the applied E.M.F. Thus $i = \frac{A}{d} \frac{ne^2\lambda v}{4\alpha\theta} E$, which leads at once to Ohm's law. Comparing with the equation $i = \frac{A}{d} \sigma E$ where σ is the specific conductivity, we see that the specific conductivity is given by $\frac{ne^2\lambda v}{4\alpha\theta}$, and is constant for a given temperature. The only quantities in this expression which vary for different substances are λ and n . It does not seem probable that the variations in λ will be very great. The conductivity of a substance therefore should depend mainly upon n , the number of free electrons per unit volume. It is found experimentally that for most pure metals the conductivity is inversely proportional to the absolute temperature θ . Since α is a constant this leads to the result that $n\lambda v$ is independent of the temperature.

143. Relation of electrical and thermal conductivities. Law of Wiedemann and Franz. Suppose that one part of a metallic conductor is heated. The electrons in the heated part have their velocities increased to correspond with the new value of the temperature. The electrons moving away from the heated part will therefore have a greater energy than those moving towards it. There will thus be a transference of energy from the hot to the cold part of the conductor, or in other words there will be conduction of heat through the metal by the electrons. It is known that non-conductors of electricity are very poor conductors of heat. It seems probable therefore that the conduction by the electrons is very much greater than that due to the atoms of the substance.

Assuming that the atmosphere of electrons in the metal can be treated as a gas, the thermal conductivity k of the electrons should be given by

$$k = \frac{\pi}{8} nva\lambda \quad (123)$$

(see O. Meyer, *Kinetic Theory of Gases*), where n , v , a and λ have the same significance as in the equation for electrical

conductivity. Neglecting any conductivity due to the molecules this will be the thermal conductivity of the metal. Thus the ratio of the thermal to the electrical conductivity is given by

$$\frac{k}{\sigma} = \left(\frac{\pi}{8} n v \alpha \lambda \right) / \left(\frac{n e^2 \lambda v}{4 \alpha \theta} \right) = \frac{\pi}{2} \left(\frac{\alpha}{e^2} \right)^2 \theta. \quad (124)$$

The ratio of the thermal to the electrical conductivity should at a given temperature therefore be independent of the nature of the conductor. This is the well-known law of Wiedemann and Franz. Again this ratio should be directly proportional to the absolute temperature, that is, its temperature coefficient should be 3.67×10^{-3} per degree Centigrade. The following table shews that, for most pure metals, these deductions from the electron theory are very approximately true.

TABLE X

Ratio of thermal to electrical conductivity

Material	k/σ at 18° C.	Temperature coefficient
Copper	6.7×10^{10}	3.9×10^{-3}
Silver	6.9×10^{10}	3.7×10^{-3}
Gold	7.1×10^{10}	3.7×10^{-3}
Lead	7.2×10^{10}	4.0×10^{-3}
Tin	7.4×10^{10}	3.4×10^{-3}
Platinum	7.5×10^{10}	4.6×10^{-3}
Palladium	7.5×10^{10}	4.6×10^{-3}
Iron	8.0×10^{10}	4.3×10^{-3}

We can moreover obtain a numerical value for the expression (124). We have (121)

$$\alpha = \frac{1}{2} \frac{m v^2}{\theta} = \frac{1}{2} \frac{(9 \times 10^{-28})(11 \times 10^6)^2}{273} = 2 \times 10^{-16} \text{ (approx.)},$$

substituting for m the mass of an electron (§ 50) and for v its thermal velocity at 0° C. (273° approx.) (§ 142) while

$$e = 1.57 \times 10^{-20} \text{ e.m.u.}$$

Hence

$$\frac{k}{\sigma} = \frac{\pi}{2} \left(\frac{2 \times 10^{-16}}{1.57 \times 10^{-20}} \right)^2 291$$

$$= 7.4 \times 10^{10}$$

at a temperature of 18° C.

The agreement of the calculated value with the mean of the experimental results given in the table is very remarkable considering the nature of the assumptions made in the course of the argument, and the possible errors in the data used; and may be regarded as giving considerable weight to the electron theory of conduction.

144. Thermoelectric effects. If we assume that the number of electrons per unit volume is different, in different conductors, we can obtain a qualitative explanation of the various thermoelectric effects. Thus, considering the electrons as a gas, if the number per unit volume in one conductor is greater than in the other, the electronic pressure in the first will be greater than that in the second; so that when the two are brought into metallic contact there will be a flow of electrons from the first to the second, until the charges carried by the electrons so transferred produce a difference of potential sufficient to prevent any further transference. There will thus be established a permanent contact difference of potential between the two metals.

Again if we wish to transfer electrons from the metal of lower to the metal of higher electronic pressure work must be done against this difference of pressure. Thus when a current is sent through the junction work must be done and energy is thus absorbed in the form of heat. Similarly if the current is reversed energy is liberated in the form of heat. This is obviously the Peltier effect.

An expression can easily be obtained for this effect. Let π be the work done per unit quantity of electricity. π is the coefficient of the Peltier effect. Thus

$$\pi = \int_{v_1}^{v_2} p dv.$$

Now by the kinetic theory of gases

$$p = \frac{1}{3}nmv^2 = \frac{2}{3}na\theta$$

and since unit quantity of electricity contains $\frac{1}{e}$ electrons

(where e is the electronic charge) the volume v occupied by the $\frac{1}{e}$ electrons in the unit quantity transferred will be $\frac{1}{ne}$ where n is the number of electrons per unit volume.

$$\therefore n = \frac{1}{ev} \quad \text{and} \quad p = \frac{2}{3} \frac{\alpha\theta}{ev}$$

and

$$\begin{aligned} \pi &= \int_{v_1}^{v_2} p dv = \frac{2}{3} \frac{\alpha}{e} \theta \int_{v_1}^{v_2} \frac{dv}{v} \\ &= \frac{2}{3} \frac{\alpha}{e} \theta \log_e \frac{v_2}{v_1} \\ &= \frac{2}{3} \frac{\alpha}{e} \theta \log_e \frac{N_1}{N_2} \end{aligned}$$

where N_1 and N_2 are the number of electrons per unit volume in the two conductors. This result was given by Sir J. J. Thomson.

The phenomena just described have been dealt with to illustrate the nature of the electron theory of matter and the kind of progress which has already been made. In many directions, however, the theory is as yet only tentative, and the underlying assumptions still under discussion. In particular until the actual arrangement of electrons in the atomic systems is more accurately determined, and until more is known as to the nature of the action which causes energy to be radiated and absorbed in definite "quanta," the principles of the subject cannot be said to have been definitely laid down. For this reason, as well as for the reason that the mathematical analysis involved is often of the most intricate kind, we shall not pursue the subject further in the present volume.

TABLE XI

Table of Atomic Data

Electronic charge, e	4.7×10^{-10} e.s. units
e/m for electron	1.57×10^{-20} e.m. units
Mass of an electron	1.774×10^7 e.m. units per gm.
Radius of electron	8.9×10^{-28} gm.
E/m for α -particle	1.85×10^{-13} cm.
Mass of α -particle (helium atom)	4.823×10^3 e.m. units per gm.
e/m , hydrogen ion in solution	6.5×10^{-24} gm.
Mass of hydrogen atom	9.6×10^3 e.m. units per gm.
Radius of hydrogen molecule	1.64×10^{-24} gm.
Gas molecules per c.c. at N.T.P.	1.21×10^{-8} cm.
Radius of nucleus of hydro- gen atom	2.705×10^{19}
Wave length of X-rays (char- acteristic K rays from silver)	$< 10^{-13}$ cm.
Wave length of hard γ -rays	0.56×10^{-8} cm.
	7×10^{-10} cm.

REFERENCES

Sir J. J. Thomson's *Conduction of Electricity through Gases* (2nd edition), 1906, contains a full account of the whole of the subject treated of in the present volume with the exception of the portions on Radio-activity (Chaps. XIII–XV), and is the standard authority for all the work done prior to its date of publication. Much progress has, however, been made in many branches of the subject since the volume appeared.

J. S. Townsend's *Electricity in Gases* (1915) contains a full account of the subject-matter of Chaps. II–VII of the present volume, and should specially be consulted on the subjects of Ionization by Collision and the Spark discharge (Chap. VII).

Sir E. Rutherford's *Radio-active substances and their radiations* (1912), is the standard work on the subject of Radio-activity (Chaps. XIII–XV) and also contains much information on the radiations from these substances (Chaps. XI, XII).

On the more theoretical side O. W. Richardson's *Electron theory of Matter* (2nd edition, 1916) and N. R. Campbell's *Modern Electrical Theory* (2nd edition, 1913) may be consulted.

On the special subjects treated of in the chapters named the following books and original memoirs may be consulted:

- Chap. IV. J. Perrin, *Les Atomes* (1914). English translation, Ham-
mick, 1916.
C. T. R. Wilson, "The Photography of Particles ejected
from Atoms." *Proc. Roy. Soc.* (1913).
A. Millikan, "Elementary electric charge." *Physical Review*
(1913).
- Chap. VII. Sir J. J. Thomson, *Rays of Positive Electricity and their
Application* (1913).
- Chap. VIII. O. W. Richardson, *Emission of Electricity from Hot Bodies.*
- Chap IX. A. L. Hughes, *Photo-electricity.*
H. S. Allen, *Photo-electricity.*
- Chap. X. W. H. and W. L. Bragg, *X-rays and Crystal Structure*, 1915.
G. W. C. Kaye, *X-rays* (2nd edition), 1917.

INDEX

References are to pages

- α -particles, charge on, 181, 182
 „ e/m for, 180
 „ nature of, 181
 „ production of helium from, 181
 „ range of, 185
 „ relation between range and rate of decay, 250
 „ scattering of, 192
 „ stopping power of atoms for, 191
- α -rays, 5, 180
 „ passage of, through matter, 184
- ABRAHAM, 199
- Actinium, 242
- Analysis of gases by positive ray experiments, 107
- Atom, constitution of, 253
 „ grouping of electrons in, 256
 „ mass of hydrogen, 50
 „ number of electrons in, 151, 206
 „ positive nucleus of, 255
 „ stopping power of, 191
- Atomic number, 166, 253
- Atoms, recoil, 233
- Average life of radio-active substances, 220, 242, 243
- AVOGADRO'S constant, 46, 50
- β -rays, absorption of, 202
 „ charge on, 195
 „ e/m for, 196, 200
 „ nature of, 195
 „ production of, from γ -rays, 208
 „ scattering of, 204
- BARKLA, 149, 170
- BECQUEREL, 4, 195
- BRAGG, W. H., 187
- BRAGG, W. L., 156, 164
- Brownian movements, 46
 „ „ determination of e/m from, 50
- Brush discharge, 70
- BUCHERER, 200
- CAMPBELL, 251
- CARR, 67
- Cathode, fall of potential at, 78
 „ glow, 73
 „ rays, 83
- Cathode rays, charge carried by, 84
 „ electrostatic deflexion of, 86
 „ e/m for, 92, 95
 „ magnetic deflexion of, 84
 „ magnetic spectrum of, 95
 „ nature of, 83
 „ velocity of, 92, 97
- Characteristic γ -radiation, 209
 „ X-radiation, 165
- Cloud experiments, Wilson's, 37
- Collision, ionization by, 53
- Condensation experiments, 37, 41
 „ „ determination of e by, 41
- Condensation on ions, 36
 „ „ effect of sign of charge on, 40
- Conduction through flames, 122
 „ through gases, 17
 „ through metals, 265
- Conductivity of salt vapours, 124
 „ of flames, 120
- COOLIDGE tube, 143
- CROOKES, 1, 83, 212
- CROOKES dark space, 74
- Crystals, diffraction of X-rays by, 153
 „ reflexion of X-rays by, 156
- CURIE, 4, 196, 229, 249
- Curie (unit), 230
- Current through a gas, 7
 „ „ methods of measurement of, 10
 „ thermoelectric, 269
- Dark discharge, 72
- DEWAR, 249
- Diffraction of γ -rays, 210
 „ of X-rays, 153
- Discharge, at low pressure, 73
 „ from hot bodies, 110
 „ intensity of field in, 75
 „ number of ions in, 77
 „ theory of, 79
- Discharge tube, 73 et seq.
- DOLEZALEK electrometer, 11
- DUANE, 247
- e , atomic nature of, 43

- e*, determination of, by Millikan, 43
 " " by Thomson, 41
 " " by Wilson, 42
 ,, value of, 51
e/m, for α -rays, 180
 ,, for β -rays, 196, 200
 ,, for cathode rays, 92, 95
 ,, from Zeeman effect, 263
 ,, table of values of, 96
 ,, variation of, with velocity, 198, 200
 Electrical conductivity, relation of, to thermal conductivity, 267
 Electromagnetic mass, 198
 Electrometer, Dolezalek, 11
 Electron, 1
 ,, charge on (*see e*)
 ,, electro-magnetic mass of, 198
 ,, mass of, 2, 97
 ,, motion of under magnetic field, 87
 ,, radiation emitted by, 143
 ,, under magnetic and electric forces, 89
 ,, variation of mass with speed, 198, 200
 Electrons, arrangement of in atom, 256
 ,, emitted by ultra-violet light, 126
 ,, ,, by X-rays, 176
 ,, from hot bodies, 110 (*see also* Thermions)
 ,, number of in an atom, 151, 206, 254
 ,, tracks of, 176
 Electroscopes, C. T. R. Wilson, 12
 Emanation, radium, *see* Radium emanation
 Equilibrium, radio-active, 220
 Excited activity, 231
 FARADAY, cylinder, 85
 ,, dark space, 74, 78
 ,, tubes, 143
 Flames, conductivity of, 120
 ,, distribution of potential in, 121
 FRIEDRICH and KNIPPING, 153
 γ -rays, 5
 ,, absorption of, 207
 ,, characteristic, 209
 ,, nature of, 206
 ,, production of, from β -rays, 208
 ,, secondary, 207
 ,, wave length of, 210
 Gaseous conduction, ionization theory of, 9, 17
 Gaseous conduction, variation of current with potential difference, 15, 20
 ,, with ionization by collision, 56
 Gases, normal conductivity of, 7, 251
 GEIGER, 193, 250
 Geological age, 243
 GOLDSTEIN, 83
 HAGA and WINDT, 152
 HALLWACHS, 126
 Heating effect of radium, 246
 Helium, production of, from α -rays, 181
 ,, content in uranium ores, 245
 HUGHES, 128
 Ionic mobilities, 19
 ,, calculation of, 28
 ,, effect of pressure on, 30
 ,, in different gases, 27
 ,, measurement of, by Rutherford, 23
 ,, ,, by Langevin, 24
 Ionium, 245
 Ionization by collision, 53
 ,, ,, effect of sign of charge, 54
 ,, ,, positive ions, 63
 ,, ,, Townsend's experiments, 57
 ,, variation of, with pressure and field, 60
 ,, velocity required to produce, 62
 Ionization, by ultra-violet light, 127
 ,, by X-rays, 178
 Ionization chamber, 14
 Ionization currents, 8, 56
 ,, measurement of, 10
 ,, variation of, with potential, 15
 ,, with large voltages, 52
 Ionizing potential, 63
 Ions, gaseous, 9
 ,, condensation on, 36
 ,, mobility of, 19, 23-27
 ,, motion of, in a uniform field, 19
 ,, nature of, 29, 31
 ,, produced by collision, 53, 56, 60
 ,, recombination of, 32
 K series of X-radiations, 166, 169
 Kanalstrahlen, *see* Positive rays
 KAUFMANN, 95, 196

- L* series of X-radiations, 167, 169
 LADENBURG, 264
 LANGEVIN, 24, 32
 LAUE, 152
 Lead, production of, from radium, 246
 Lines of force, 143
 LORENTZ, 200, 261
- Magnetic field, motion of charged particles in, 87
 Magnetic spectrum, 95
 MARSDEN, 194
 Mass, electromagnetic, 198
 " of atom, 50
 " of electron, 2, 97
 McCLENNAN, 251
 Measuring instruments, 11, 13
 Metallic conduction, theory of, 265
 Millicurie, 230
 MILLIKAN, 43
 Mobility of ions, *see* Ionic mobilities
- Negative glow, 73
 Nucleus, positive, of atom, 260
 Number, atomic, 166, 253
 Number of electrons in atoms, 151, 206
- Parabolas, positive ray, 102
 PASCHEN, 69, 263
 PELTIER effect, 269
 PERRIN, 2, 46, 84
 Phosphorescence, 139
 Photo-electric effect, 126
 " " and quantum theory, 132
 " " in non-metals, 138
 " " magnitude of, 133
 " " variation of, with polarization, 136
 " " with wave length, 135
 Photo-electric fatigue, 137
 " measurement of radiation, 137
 Photo-electrons, 126
 " *e/m* for, 91, 126
 " velocity of emission of, 129, 132
- PLANCK, 51, 131, 169
 PLANCK'S constant, 131
 Polarization, effect of, on photo-emission, 135
 " of X-rays, 148
 Polonium, 240
 Positive rays, 98
 " electrical measurement of, 108
 " multiple charges on, 106
 " nature of particles in, 105
- Positive rays, negative parabolas, 106
 " positive parabolas, 102
 " Thomson's experiments, 99
 Positive ray analysis, 107
 Potassium, radio-activity of, 252
- Quantum theory of radiation, 130, 169
- Radiation, emitted by stoppage of an electron, 143
 " quantum theory of, 130, 169
 Radio-active change, theory of, 215
 " constant, 219
 " deposit, analysis of, 234
 " disintegration, laws of, 218
 " equilibrium, 220
 Radio-active substances, 4
 " average life of, 220
 " half period value for, 220
- Radio-activity, of actinium, 241
 " of ordinary matter, 250
 " of potassium, 252
 " of rubidium, 252
 " of thorium, 241
 " of uranium, 212
 Radium, heating effect of, 246
 " origin of, 244
 " properties of, 225
 " separation of, from uranium ores, 225
 Radium A, 235
 " B, 236
 " C, 236, 238
 " D, 240
 Radium emanation, active deposit from, 231
 " average life of, 227
 " density of, 227
 " properties of, 227
 " rate of decay of, 228
 " volume of, in equilibrium with one gram of radium, 230
- Radium E, 240
 " F, 240
 RAMSAY and GRAY, 227
 Rayless changes, 238
 Rays, α -, 180-192
 " β -, 195-205
 " cathode, 83-97
 " γ -, 206-210
 " positive, 98-109
 " X-, 140-178
 Recoil atoms, 233

- Recombination, coefficient of, 18, 32
 Reflexion of X-rays, 156
 REGENER, 182
 RICHARDSON, 110, 116
 RÖNTGEN, 3, 140
 RÖNTGEN rays, *see* X-rays
 Rubidium, photo-electric effect in, 137
 " radio-activity of, 252
 RUNGE, 263
 RUTHERFORD, 23, 32, 181, 209, 210,
 218, 230, 252
- Saturation current, 16
 " variation of, with
 distance between
 electrodes, 17
- Secondary γ -rays, 207
 " X-rays, 147, 170
- Spark discharge, theory of, 65
 Sparking potential, 67
 " Paschen's law of,
 69
 " variation of, with
 temperature, 70
- Spectrum, magnetic, 95
 " X-ray, 165
- STOKES, 143
 Stopping power for α -particles, 191
 STRUTT, 245
- Thermal conductivity, 267
 Thermionic currents, 110
 " variation of, with
 temperature, 112
- Thermionic emission, 111
 " from alkali metals,
 119
 " from oxides, 117
 " intensity of, 118
 " theory of, 112
- Thermions, 110
 " nature of, 111
 " positively charged, 118
- THOMSON, J. J., 2, 21, 42, 76, 86, 92,
 99, 124, 150, 176, 270
 Thorium, radio-activity of, 241
 TOWNSEND, 57, 60, 61, 65, 66
- Uranium, disintegration of, 212
 " production of helium from,
 245
 " production of radium from,
 244
 Uranium X, emission of β -rays from;
 " rate of decay of, 212
 " separation of, 212
- Wave length, of γ -rays, 210
 " of X-rays, 162
 " effect of, on photo-elec-
 tric emission, 135
- WEHNELT cathode, 118
 WHIDDINGTON, 168
 WIECHERT, 97
 WIEDEMANN and FRANZ, Law of, 267
 WILSON, C. T. R., 4, 7, 12, 36, 37, 41,
 176
 WILSON, H. A., 42, 78, 125
 WILSON, W., 203
- X-rays, 140
 " absorption of, 170, 173
 " coefficient of absorption of,
 and wave length, 173
 " corpuseular radiation emitted
 by, 176
 " diffraction of, 153
 " fluorescent, 172
 " homogeneous, 170, 172
 " interference of, 151
 " ionization by, 178
 " production of, 140
 " rectilinear propagation of, 140
 " reflexion of, 156
 " scattering of, 147
 " theory of emission of, 143
 " track of, 176
 " wave length of, 162
 X-rays, characteristic, 147
 " emission of, 168
 X-rays, scattered, distribution of, 148
 " energy of, 150
 " polarization of, 148
 X-ray spectra, 165
 X-ray spectrometer, 160
 X-ray tube, 141, 142
- ZEEMAN effect, 261



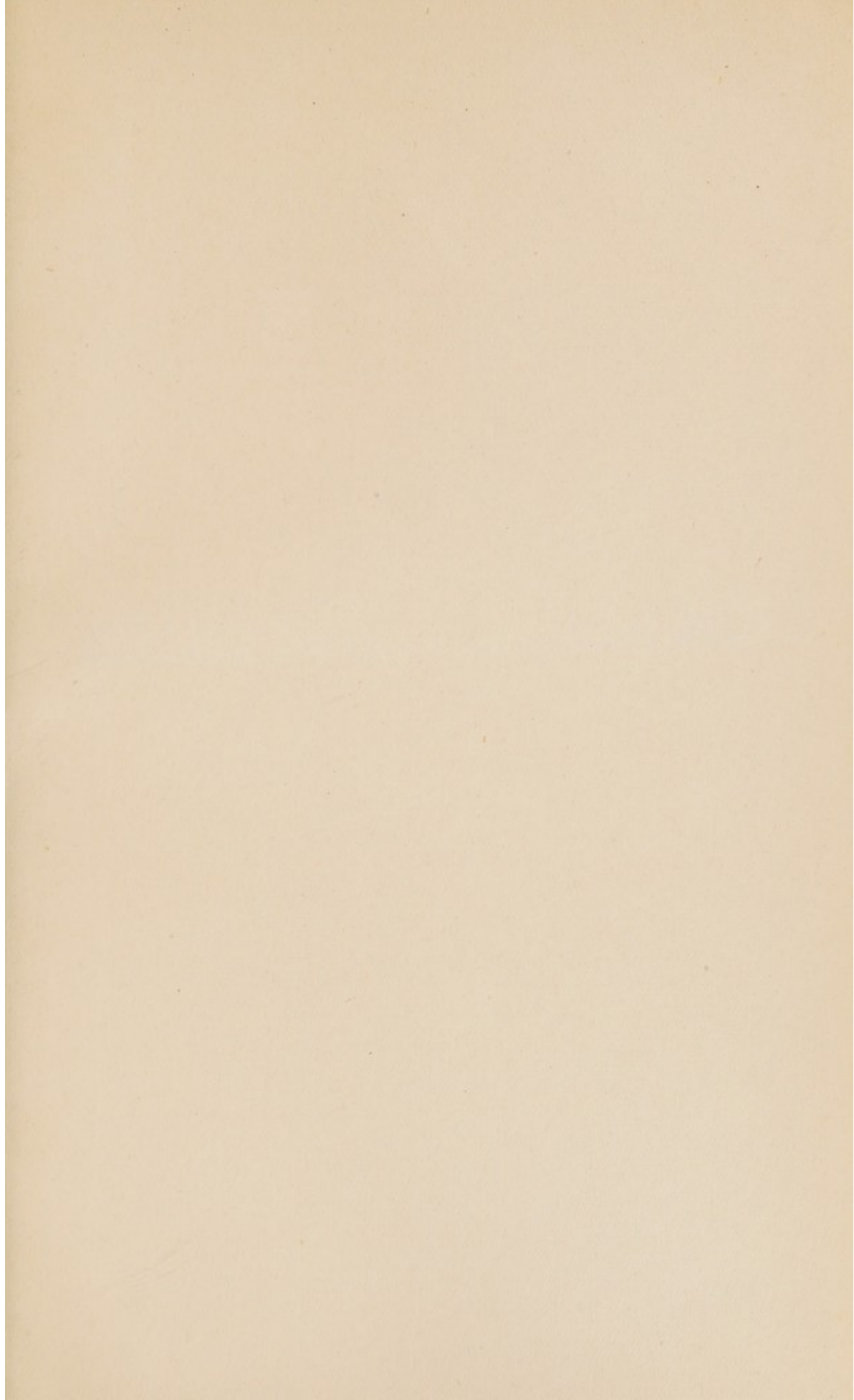

LONDON HOSPITAL MEDICAL COLLEGE

WILSON HOSPITAL MEDICAL COLLEGE

