

## **Sanitary science applied to buildings and public works / [Henry Adams].**

### **Contributors**

Adams, Henry, 1846-1935.

### **Publication/Creation**

London : Chapman & Hall, 1926.

### **Persistent URL**

<https://wellcomecollection.org/works/wvargs5p>

### **License and attribution**

The copyright of this item has not been evaluated. Please refer to the original publisher/creator of this item for more information. You are free to use this item in any way that is permitted by the copyright and related rights legislation that applies to your use.

See [rightsstatements.org](https://rightsstatements.org) for more information.



Wellcome Collection  
183 Euston Road  
London NW1 2BE UK  
T +44 (0)20 7611 8722  
E [library@wellcomecollection.org](mailto:library@wellcomecollection.org)  
<https://wellcomecollection.org>



HISTORICAL

# THE ROYAL SOCIETY

FOR THE PROMOTION

## OF HEALTH

90 Buckingham Palace Road, London, S.W.1

Class No. EB.50.

Acc. No.....

This book is returnable on or before the last date Marked below

30 DEC 1965



22101918010

Med  
K20652

THE ROYAL SOCIETY  
for the Promotion  
OF HEALTH  
LIBRARY

*Journal*  
**ROYAL SANITARY INSTITUTE**

LIBRARY REGULATIONS

1. Books may be borrowed by Fellows, Members and Associates personally or by a messenger producing a written order. The person to whom books are delivered shall sign a receipt for them in a book provided for that purpose.

2. Books may be sent through the post, or by some equivalent means of carriage, upon a written order. All charges of carriage to the Institute shall be defrayed by the borrower.

3. A borrower may not have more than three volumes in his possession at one time.

4. A borrower will be considered liable for the value of any book lost or damaged while on loan to him, and if it be a separate volume, for the value of the whole work rendered imperfect.

Marking or writing in the volumes is not permitted, and borrowers are requested to call attention to damage of this character.

5. Books may be retained for 28 days. Periodicals may be retained for 14 days. Applications for extension of the loan period must be made in writing before its expiry. No book may be kept longer than 3 months.

New books will not be lent until after the expiration of one month from the date of their having been received by the Institute. The current number of a periodical may not be borrowed.

6. Borrowers retaining books longer than the time specified, and neglecting to return them when demanded, forfeit the right to borrow books until the volume or volumes be returned, and for such further time as may be ordered.

Any borrower failing to comply with a request for the return of a book shall be considered liable for the cost of replacing the book, and the Council may, after giving due notice to him, order the book to be replaced at his expense.

No volume may be reissued to the same borrower until at least seven days have elapsed after its return, neither may it be transferred by one borrower to another.

7. Books may not be taken or sent out of the United Kingdom.

8. Volumes returned through the post must be securely packed in a box, or otherwise protected.

Parcels should be addressed :

THE ROYAL SANITARY INSTITUTE,  
90, BUCKINGHAM PALACE ROAD,  
LONDON, S.W.1.



Digitized by the Internet Archive  
in 2017 with funding from  
Wellcome Library

<https://archive.org/details/b29809939>

**SANITARY SCIENCE**

## TECHNICAL BOOKS

### DIAGRAMMETTES.

By W. H. KNIGHT.

The demand for the sixth edition of this series of diagrams and diagrammettes testifies to its continued popularity as a compendium and lucid monitor of the increasingly important subject of Hygiene. It provides facsimile miniatures of a series of large diagrams designed for teaching Hygiene, and has obtained official recognition by the Royal College of Science, South Kensington, the County Council Technical Education Committees of Great Britain, London and Provincial School Boards, Polytechnics and Science Teaching Centres in all parts of the Kingdom.

Sixth Edition. Price 3s. net.

### ENGINEERING SCIENCE.

By ARTHUR G. ROBSON, A.M.I.M.E.

A comprehensive text-book for engineers and engineering students. It covers closely the requirements of the Board of Education Circular No. 894, the City and Guilds of London Institute, and the Union of Lancashire and Cheshire Institutes.

Demy 8vo. 213 pages. 185 figures. Price 7s. 6d. net.

### ARITHMETIC FOR ENGINEERS: Including Simple Algebra, Mensuration, Trigonometry, Logarithms, Graphs, The Slide Rule, Verniers and Micrometers.

By CHARLES B. CLAPHAM, B.Sc., Eng. (London).

Demy 8vo. Fourth Edition. 477 pages. 167 figures and over 2,000 worked and set examples with answers. Price 7s. 6d. net.

CHAPMAN & HALL, LTD.

# SANITARY SCIENCE

APPLIED TO  
BUILDINGS AND PUBLIC WORKS

BY

PROFESSOR HENRY ADAMS

M.INST.C.E., F.S.I., F.R.SAN.I., F.R.I.B.A., ETC.

*Past-President, Institution of Sanitary Engineers;*

*Life Fellow, Royal Sanitary Institute*



LONDON  
CHAPMAN & HALL, LTD.  
11 HENRIETTA ST., W.C. 2

1926

PRINTED IN GREAT BRITAIN  
BY THE ABERDEEN UNIVERSITY PRESS  
ABERDEEN, SCOTLAND

WELLCOME INSTITUTE LIBRARY	
Coll.	welMOmec
Call	
No.	WA

## AUTHOR'S PREFACE

WHILE preparing this book mainly for students it was apparent to the author that it would be eminently useful to Sanitary Engineers, Builders, Plumbers, etc., all of whom have to deal with sanitary matters and should know something of the principles underlying their practice.

As a past Chairman of the Examination Committee and Board of Examiners, and for over twenty-seven years Examiner and Member of Council of the Royal Sanitary Institute, the author claims to know something of the subject and of the requirements of students. With such an extensive subject it is impossible to include every detail within a reasonable compass, but the Examination Syllabus has been taken as the scope to be comprised. Each chapter is followed by questions that have been set in the examinations, so that a student may test his progress as he goes along. It is hoped that he will desire further information on many points that are here dealt with rather summarily, and he is recommended to refer to the special authorities on such matters; the author's object is simply to give a general introduction.

A better arrangement of the material than that given by the syllabus might possibly have been devised, but it was thought on the whole that it would be advantageous to keep to this as being more intelligible to students preparing for the Examination. The complete Syllabus is published as an Appendix by permission of the Royal Sanitary Institute.

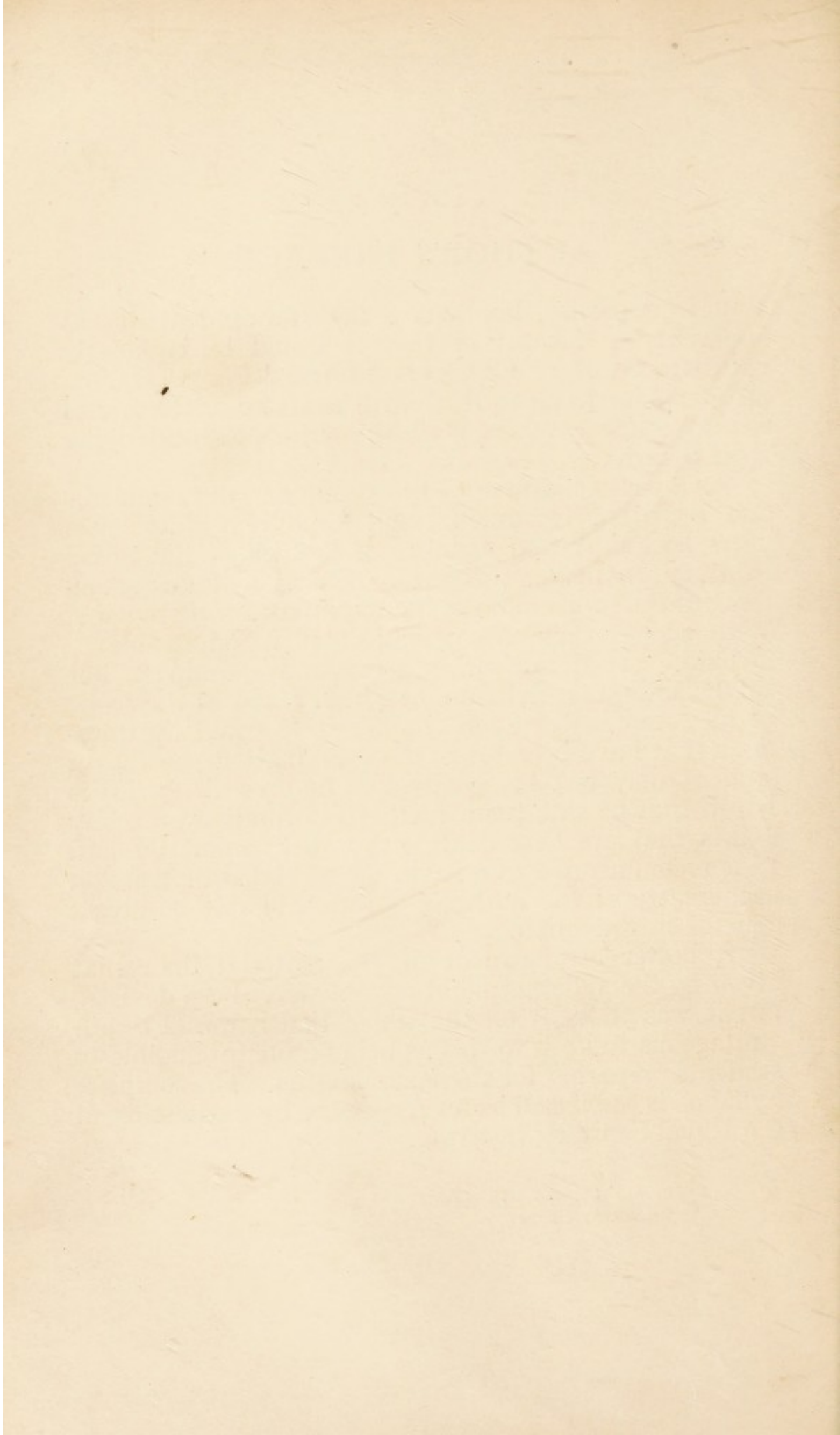

## CONTENTS

	PAGE
SECTION I. ELEMENTARY PHYSICS AND CHEMISTRY . . . . .	I
CHAPTER I. The principles of hydrostatics, hydraulics, and pneumatics—The composition of air and water—The diffusion and movement of gases and liquids—The velocity and discharge of liquids and gases through pipes and orifices . . . . .	3
CHAPTER II. Porosity — Capillarity — Absorptivity — Permeability—Definition of vacuum—Action of siphon—Principle of suction—The construction of lift and force pumps and hydraulic rams . . . . .	14
CHAPTER III. Production and transmission of heat, and effects of heat on solids, liquids, and gases . . . . .	22
CHAPTER IV. Elementary chemistry . . . . .	28
CHAPTER V. Meteorological instruments, their construction, adjustment, and reading . . . . .	33
SECTION II. LOCAL CONDITIONS . . . . .	43
CHAPTER VI. Aspect, elevation—Hill, plain, and valley—Distance from sea—Influence of surrounding objects—Winds, rainfall, humidity—Soil and subsoil, and its drainage—Pollution of soil—Sanitary precautions as to healthiness of site—Ground air and ground water and their pollution . . . . .	45
SECTION III. AIR, LIGHTING AND WARMING . . . . .	51
CHAPTER VII. Air movements—Sources of pollution—Principles of ventilation—Air space and quantity required—Methods of, and appliances for, ventilation—Ventilation of public buildings, hospitals, schools, factories, dwelling-houses, etc. . . . .	53
CHAPTER VIII. Over-crowding on space and in buildings—Air space surrounding buildings—Angle of daylight illumination—Methods of artificial lighting, advantages and disadvantages—Size and position of windows . . . . .	60
CHAPTER IX. Warming buildings by open fire, stove, hot water, steam, hot air . . . . .	67

	PAGE
SECTION IV. WATER . . . . .	77
CHAPTER X. Sources of supply—Gathering grounds— Measuring the flow of water—Physical characteristics of various waters—Impounding, storage, and service reservoirs—Filtration, softening, and other purifying processes . . . . .	79
CHAPTER XI. Requirements and supply of towns, villages, and country houses, cottages—Mains, pipes, fittings, and protective precautions—Taking samples for analysis	92
SECTION V. DRAINAGE, SEWERAGE, AND SANITARY APPLIANCES . . . . .	99
CHAPTER XII. The proper conditions of good drainage—Re- modelling old drainage—The planning and construction of new drains and sewers—Disposal of surface and rain- water . . . . .	101
CHAPTER XIII. Advantages and disadvantages of various sanitary appliances—Inspection and testing of drainage work and appliances . . . . .	113
CHAPTER XIV. The various systems of dealing with sewage and house refuse—Disinfecting apparatus and disinfec- tants . . . . .	124
SECTION VI. MATERIALS AND CONSTRUCTION . . . . .	135
CHAPTER XV. General description of materials used in construction, namely, metals, timber, cements, mortars, concrete, stones, bricks, and tiles, terra cotta, stoneware, materials for covering roofs, and materials used for preservation and decoration, such as rendering, plaster work, paints, and varnishes; as to their perviousness to moisture, conductivity of heat, facility of working and using, strength, durability, power to withstand fire, purposes for which suitable . . . . .	137
CHAPTER XVI. General principles of construction as apply- ing to: Foundations in various soils—Walls; hollow walls, damp course, bond—Floors for basements or cellars, fire-proof partitions—Roofs, covering for same, gutters, hips, valleys—Fire-proof construction . . . . .	148
CHAPTER XVII. Principles of calculating areas, cubic space —Interpretation and drawing of plans and sections to scale . . . . .	159
CHAPTER XVIII. Road construction—General provisions of the Building Acts and By-Laws . . . . .	165
SECTION VII. EXAMINATIONS . . . . .	171
CHAPTER XIX. How to pass and how to fail in an examina- tion . . . . .	173
APPENDIX. Examination Syllabus of Royal Sanitary Institute	181
INDEX . . . . .	185

## LIST OF ILLUSTRATIONS

FIG.	PAGE
1. Hydraulic gradient of pipe line . . . . .	8
2. Action of siphon . . . . .	16
3. Common suction pump . . . . .	16
4. Single-acting plunger pump . . . . .	16
5. Double-acting bucket and plunger pump . . . . .	17
6. Centrifugal pump . . . . .	17
7. Simple hydraulic ram for lifting water . . . . .	18
8. Hydraulic ram worked by impure water . . . . .	18
9. Dry and wet bulb thermometers . . . . .	34
10. Section through rain gauge fixed in position . . . . .	35
11. Campbell-Stokes sunshine recorder . . . . .	37
12. Robinson's cup anemometer . . . . .	37
13. "Windstar" . . . . .	39
14. Vernier on barometer . . . . .	39
15. Cottage showing suitable aspect with regard to north point . . . . .	46
16. Mode of land drainage . . . . .	46
17. Block plan of building showing horizontal angle of light obstructed from window . . . . .	61
18. Elevation of building showing vertical angle of obstruction . . . . .	61
19. Tank system of heating by hot water . . . . .	69
20. Single pipe cylinder system of heating by hot water . . . . .	69
21. Two-pipe cylinder system . . . . .	70
22. Hot-water radiator partly in section . . . . .	71
23. Two-pipe underfed system of central heating . . . . .	71
24. One-pipe drop-pipe system of central heating . . . . .	72
25. High-pressure hot-water heating for churches . . . . .	72
26. Calorifier for heating water by steam . . . . .	73
27. High-pressure calorifier . . . . .	73
28. Roberts' rain-water separator with dirty water passing to waste . . . . .	80
29. Elevation of separator . . . . .	80
30. Clean water passing to storage . . . . .	80
31. Rain-water filter and storage tank . . . . .	82
32. Gathering ground for water supply . . . . .	82
33. Section through earthen dam showing impermeable puddle wall . . . . .	83
34. Section through masonry dam . . . . .	83
35. Gauging weir or measuring notch . . . . .	83
36. Distinction between shallow and deep wells . . . . .	88
37. Section through strata showing artesian well . . . . .	88

FIG.	PAGE
38. Spigot and socket joint in cast-iron pipes . . . . .	94
39. Turned and bored spigot and socket joint in cast-iron water pipes . . . . .	94
40. Flanged joint in cast-iron pipes . . . . .	94
41. Turned, bored, and flanged joint . . . . .	94
42. Fire hydrant with sluice valve . . . . .	95
43. Section through cistern ball-cock . . . . .	95
44. Longitudinal section through disconnecting manhole . . . . .	102
45. Cross-section through same . . . . .	102
46. Hellyer's grease trap . . . . .	103
47. Method of setting out standard oval sewer . . . . .	105
48. Working section of same . . . . .	105
49. Field's flushing cistern for flat sewers . . . . .	105
50. Section through a Shone ejector . . . . .	106
51. Section through trench with single struts and poling boards . . . . .	107
52. Trench with double struts and single poling boards . . . . .	107
53. Trench with walings, struts, and poling boards . . . . .	107
54. Trench with close poling boards, struts, and walings . . . . .	107
55. Section of deep trench, showing close poling boards in tiers, breaking joint, walings, and struts, and stage for receiving materials thrown up in excavating . . . . .	108
56. Longitudinal section of trench, showing sight-rails and boning-rod . . . . .	109
57. Cross-section through trench . . . . .	109
58. Boning-rod . . . . .	109
59. Cement joint in ordinary stoneware socket pipes . . . . .	110
60. Stanford's original joint with plastic bituminous composition . . . . .	110
61. Doulton's self-adjusting bituminous joint . . . . .	110
62. Doulton's composite or double-seal joint . . . . .	110
63. Hassall's double-lined joint . . . . .	110
64. Pan and container water-closet . . . . .	113
65. Long hopper W.C. basin . . . . .	113
66. Wash-down closet . . . . .	114
67. Wash-out closet . . . . .	114
68. Valve closet . . . . .	114
69. Winn's waste-preventer flushing cistern . . . . .	115
70. Farmiloe's waste-preventer flushing cistern . . . . .	115
71. Lead soil pipe joining stoneware pipe . . . . .	116
72. Duck-foot bend at bottom of cast-iron soil pipe . . . . .	116
73. Moule's earth-closet with pail removed . . . . .	116
74. Action of chucker for earth-closet . . . . .	116
75. Earth-closet made by the British Sanitary Co. . . . .	116
76. Cesspool and disconnecting chamber . . . . .	117
77. Day's Stafford waste water-closet . . . . .	118
78. Duckett's slop water-closet . . . . .	118
79. Wiped joint in lead pipes . . . . .	119
80. Plumber's copper-bit joint . . . . .	119
81. Flange joint in lead pipe at floor level . . . . .	119
82. Screw-down bib-cock with union . . . . .	120
83. Land prepared for broad irrigation . . . . .	125

# LIST OF ILLUSTRATIONS

xi

FIG.	PAGE
84. Broad irrigation or filtration . . . . .	125
85. General plan of biological treatment of sewage . . . . .	126
86. Longitudinal section through same . . . . .	126
87. Arrangement of septic tank and filters for small institution	126
88. Section through activated sludge plant . . . . .	128
89. Plan of same . . . . .	128
90. Section of Horsfall's destructor furnaces . . . . .	130
91. General arrangement of disinfecting station . . . . .	131
92. Pegging out excavations . . . . .	149
93. Damp-proof course and air brick for ventilation . . . . .	151
94. Base of hollow brick wall . . . . .	151
95. Section of cellar wall protected from damp . . . . .	152
96. Cast-iron eaves gutter . . . . .	153
97. Section through a V-gutter . . . . .	153
98. Section through box gutter . . . . .	153
99. Section through parapet gutter showing foot of roof truss	153
100. Lead work on roof . . . . .	154
101. Stepped flashing at gable and on chimney stack . . . . .	155
102. General view of hipped roof . . . . .	162



SECTION I.  
ELEMENTARY PHYSICS AND CHEMISTRY.

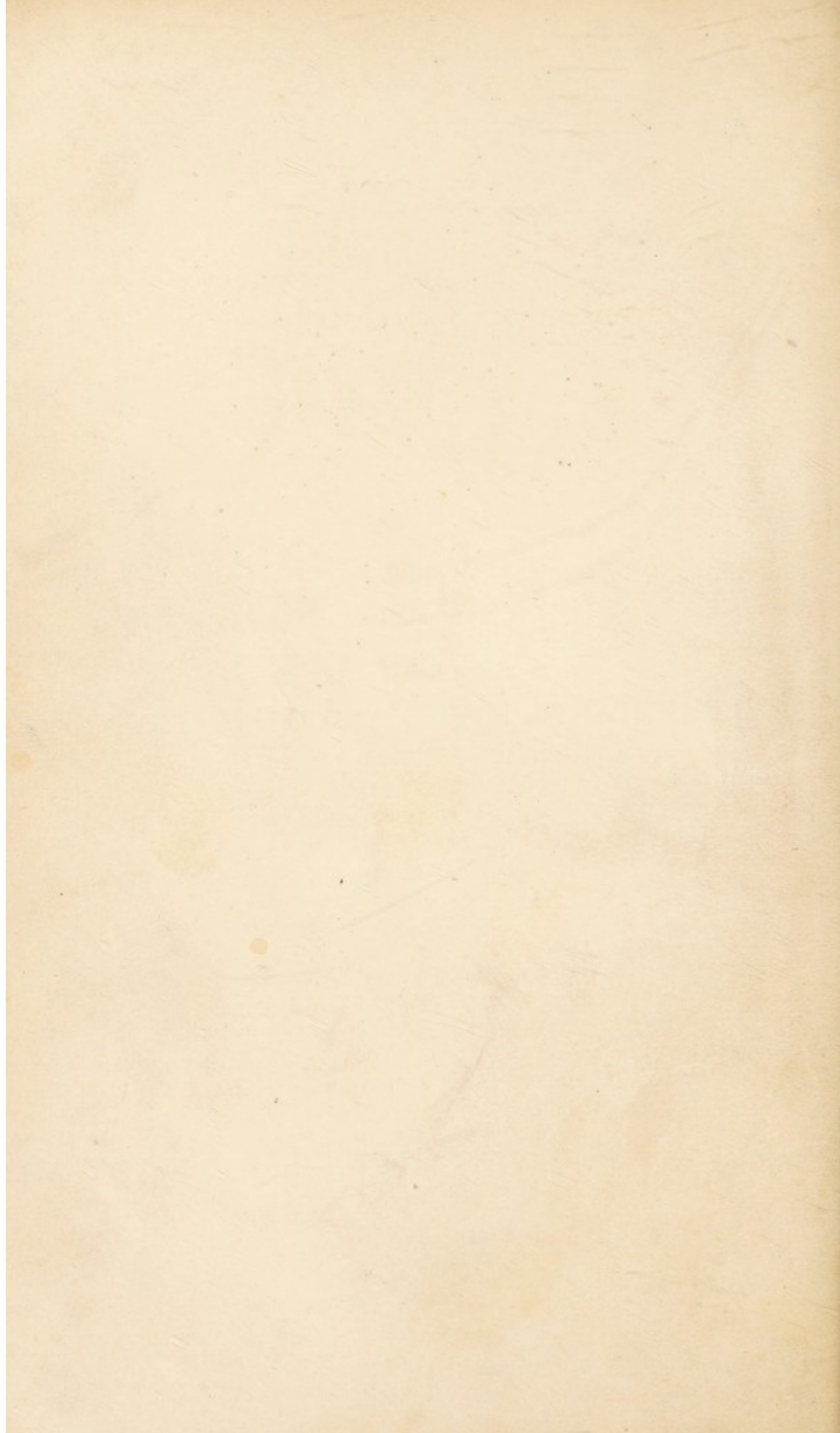

## CHAPTER I.

The principles of hydrostatics, hydraulics and pneumatics—The composition and properties of air and water—The diffusion and movement of gases and liquids—The velocity and discharge of liquids and gases through pipes and orifices.

HYDROSTATICS may be understood as dealing with water at rest, hydraulics with water in motion. Pure water consists of a union of the gases oxygen and hydrogen in the proportion of two volumes of hydrogen to one volume of oxygen, or by weight, one part of hydrogen to eight parts of oxygen. A gallon of water weighs 10 lb. at 62° F. and 30-in. bar.\* A cubic foot contains approximately 6¼ gallons and weighs 62½ lb. A cubic foot of sea water weighs 64 lb., a cubic foot of ice weighs 58 lb. Ice may be cooled below 32° F., but not water. Pure water is the standard of specific gravity for solids and liquids, and therefore equals 1. Bodies lighter than water have a specific gravity less than 1, and those heavier more than 1. The following are examples: cork, .24; fir wood, .5; ice, .917; slate, 2.67; cast-iron, 7.2; lead, 11.45; mercury, 13.59. The specific gravity of a substance is found by dividing its weight in air by the difference between its weight in air and in water. A substance with a specific gravity of, say, .5, is only half as heavy as water; if the specific gravity be, say, 3, it is three times as heavy as water. The pressure caused by water at rest is proportional to the depth below the surface of the point considered, thus the pressure on the bottom of a cistern containing 6 ft. depth of water will be  $\frac{6 \times 62\frac{1}{2}}{144} = 2.6$  lb. sq. in., or at a scullery tap 20 ft. below the surface of water in cistern  $\frac{20 \times 62\frac{1}{2}}{144} = 8.68$  lb. sq. in. The pressure per square inch is

\* I.e. a pressure of 30 inches height of mercury in a barometer.

equal to the weight of a column of water with a sectional area of 1 sq. in., and a height equal to the head. Taken generally : Feet head  $\times .434 =$  lb. per sq. in., or lb. per sq. in.  $\times 2.3 =$  ft. head. Any horizontal length of pipe intervening does not alter the standing pressure but will reduce the pressure when the water is flowing by reason of the amount absorbed in friction. The pressure of the atmosphere averages 14.7 lb. sq. in., which is equivalent to a static head of water of 34 feet, and therefore the pressure of the atmosphere cannot force water higher than this up the suction pipe of a pump. The capacity of a pipe varies as the square of the diameter, so that a 2-inch pipe has four times the capacity of a 1-inch pipe. The area of a circle is the diameter squared and multiplied by .7854 or  $\frac{11}{14}$ , but in comparing the sectional areas of different pipes this multiplier may be omitted as it applies to all alike. Thus a 3-inch and 4-inch pipe are together equivalent to a 5-inch pipe, because  $3^2 + 4^2 = 5^2$ . Although the capacity of pipes varies in this simple proportion, it does not follow that the quantity of water they can convey will follow the same proportions ; the friction being relatively greater in small pipes, the flow will be relatively less.

The natural velocity of water uncontrolled, as when escaping from a hole in the side or bottom of a tank, is the same as that of any falling body (known as Torricelli's theorem), viz.  $v = \sqrt{2gh}$ , where  $v =$  velocity in ft. per sec.,  $g =$  accelerating force of gravity  $= 32$ , and  $h =$  head in feet above outlet. Owing to the water coming to the hole from all directions the jet converges at a distance of half the diameter from the orifice (called the *vena contracta* or contracted vein), giving there a sectional area of rather less than two-thirds of the hole. The *coefficient of contraction* for a circular orifice is 0.64. The *coefficient of discharge* is the fraction represented by the actual discharge divided by the theoretical discharge. For a circular orifice this is 0.62. The *coefficient of velocity* is the fraction represented by the coefficient of discharge divided by the coefficient of contraction ; for a circular orifice  $\frac{0.62}{0.64} = 0.97$ .

The time required to empty a tank when  $A =$  area of water surface in sq. ft.,  $H =$  depth of water in feet to centre of orifice,  $a =$  area of outlet in sq. ins.,  $c =$  coefficient for outlet,  $g =$  force of gravity 32,  $t =$  time in secs.,  $d =$  diameter of outlet in ins.

Then

$$t = \frac{288A}{ac} \times \sqrt{\frac{H}{2g}}, \text{ or approximately } t = \frac{75A\sqrt{H}}{d^2}.$$

The time taken to fill a tank by two pipes of different sizes, running at the same time, may be found thus: If  $t$  be the time occupied in filling by smaller pipe alone, and  $T$  be time occupied in filling by larger pipe alone, the time occupied by both running together will be  $= \frac{t \times T}{t + T}$ . A tank emptying itself through

a hole in the bottom will discharge twice as much in the same time if kept full. The water pressure in lb. sq. in. against any surface is the area of the surface  $\times$  depth of its centre of gravity (c.g.) below the top of the water  $\times$  .434. The pressure is equal in all directions and perpendicular to the containing surface. When a solid body floats on a liquid the weight of the liquid displaced is equal to the weight of the body. The surface of still water is horizontal.

The discharge through pipes varies approximately as the square of the internal diameter. More exactly, let  $G$  represent the gallons flowing or required per minute,  $L$  the whole length in yards, whether vertical or horizontal,  $d$  = the internal diameter of the pipe in inches,  $h$  the head in feet required to overcome friction,  $h^1$  the head to produce velocity,  $H$  the total head, then

$$h = \frac{G^2L}{240d^5}, \quad h^1 = \frac{G^2}{215d^4}, \quad H = h + h^1.$$

If the total  $H$  found thus does not agree with the given head, the true discharge will be the assumed discharge  $\times$  square root of true head  $\div$  square root of head  $H$  found above, without allowing for bends. For example: with a head of 20 feet it is desired to deliver 100 gallons per minute (called galmins) through a series of 3-inch pipes to a distance of 120 yards. Then

$$h = \frac{G^2L}{240d^5} = \frac{100^2 \times 120}{240 \times 3^5} = 20.58, \quad h^1 = \frac{G^2}{215d^4} = \frac{100^2}{215 \times 3^4} \\ = .57, \quad H = 20.58 + .57 = 21.15 \text{ ft.},$$

but we have only 20 ft. available, therefore the quantity of water that can be conveyed per minute will be

$$\frac{100 \times \sqrt{20}}{\sqrt{21.15}} = 100 \times \sqrt{\frac{20}{21.15}} = 100 \times \sqrt{.9456}$$

$$= 100 \times .9723 = \text{say, } 97\frac{1}{4} \text{ galmins.}$$

The head required to produce velocity is proportionately so small that it is frequently omitted from the calculations. When the diameter, length, and head are known, the gallons will be obtained direct from the formula

$$G = \sqrt{\frac{10320d^5H}{48d + 43L}} = 97.78 \text{ galmins.}$$

The extra friction due to each bend may be found approximately, for a bend with a radius of  $2\frac{1}{2}$  diameters of the pipe, by adding to the length  $L =$  four times the diameter of the pipe in inches.

The hydraulic mean gradient of a line of pipes is the total horizontal length divided by the total fall. The actual hydraulic gradient of a line of pipes depends upon their diameter, fall, internal condition, and quantity of water flowing. If a series of vertical pipes, open at the top, were inserted at intervals along the line, the hydraulic gradient would be given by a line drawn through the various levels at which the water would stand. To draw this line for a series of pipes, assume any given quantity of water to be passed through, say 100 gallons per minute, then find the head necessary for this quantity for each size of pipe according to its diameter and length; then, as the total head for assumed quantity is to the total available head, so is the calculated head for assumed quantity in each length respectively to the available head for that length, the heads giving the actual hydraulic gradient. The friction will vary as the square of the quantity of water flowing. For example, take 1000 yds. of 4-in. pipe, 750 yds. 3-in. pipe, the total head available being 150 ft. The head to overcome friction at 100 galmins will be

$$\frac{G^2L}{240d^5} =$$

for the 4-in. pipe  $\frac{100^2 \times 1000}{240 \times 4^5} = 40.7 \text{ ft.}$

„ 3-in. „  $\frac{100^2 \times 750}{240 \times 3^5} = 128.6 \text{ ft.}$

giving a total head of 169.3, say 170 ft., but the total head available is 150 ft. We must either reduce the quantity or increase the size of pipes. Other conditions remaining unaltered, the quantity able to pass would be found thus

$$170 : 150 :: 100 : x \text{ or } \frac{150}{170} \times 100 = 88.24, \sqrt{8824} = 93.9,$$

say 94 galmins.

Or, if we substitute another 150 yds. of 4-in. pipe for the same length of 3-in. pipe, the head required for 100 galmins will be

$$\text{for the 4-in. pipe } \frac{100^2 \times 1150}{240 \times 4^5} = 46.77 \text{ ft.}$$

$$,, \quad 3\text{-in.} \quad ,, \quad \frac{100^2 \times 600}{240 \times 3^5} = \underline{102.9} \text{ ft.}$$

$$\text{Total } \underline{\underline{149.67}} \text{ ft.}$$

The available head given as 150 ft. is not measured from the surface of the water in the reservoir to the level of the pipes at the farther end, but from the lowest level in the reservoir or tank to the height at which the water must be delivered at the farther end of the pipe (see Fig. 1). The importance of knowing the hydraulic gradient for a line of pipes is that the pipe must nowhere rise above that level or an air-lock will take place. In practice the line of pipes being laid 3 ft. below the surface of the ground will rise and fall with the ground. It is under these conditions that it might rise above the hydraulic gradient unless guarded against. An air-lock is the shutting in of a portion of air in a pipe which prevents the regular flow of water. Water under direct pressure from a pump may be considered as having a head due to the pressure generated, for example, a hydraulic pressure main with water at 700 lb. per square inch is the same as if it worked with a head of 1610 ft., omitting pipe friction, but inasmuch as the accumulator pressure is generated with only a short length of hydraulic main, the 1610 ft. natural head would require to be increased to overcome the friction in the long length of piping that would be required. Water is practically incompressible, at a pressure of 2 tons per square inch it only loses one-seventieth of its volume.

The velocity of an open stream, or the liquid in a sewer, depends upon its gradient and its hydraulic mean depth. The hydraulic mean depth (H.M.D.) is the sectional area in square feet divided by the wetted perimeter in feet, and the gradient (G) or fall is generally given in feet per mile. Then the mean velocity in feet per minute =  $55 \sqrt{(\text{H.M.D.}) (2G)}$ . The surface velocity may be obtained by timing the floating of an orange over a given length, the mean velocity is then about two-thirds surface velocity. The hydraulic mean depth in a circular pipe running full or half full is one-quarter the diameter because

$$\frac{\text{sectional area}}{\text{wetted perimeter}} = \frac{d^2 \pi}{4 \pi d}, \text{ and cancelling this fraction leaves } \frac{d}{4}, \text{ but}$$

is not the same if the depth varies from these two conditions

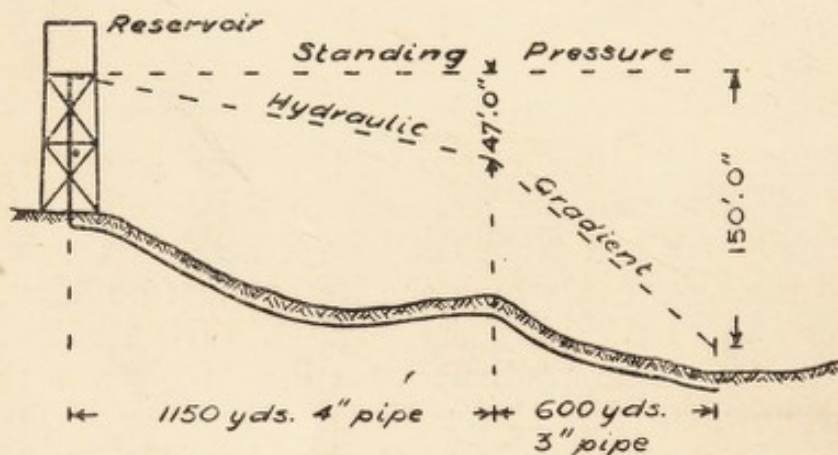

FIG. 1.—Hydraulic gradient of pipe line.

of full or half full. An approximate gradient for drains and sewers under 1 ft. diameter is 1 in 10 times the diameter in inches, and over 1 ft. diameter is 1 in 264 times diameter in feet.

The velocity of flow in a drain varies as  $\sqrt{\text{head}}$ , or, in other words, if a drain be laid with a fall of 1 in 40 to give a velocity of 3 ft. per sec., the same drain laid to a fall of 1 in 30 would give a velocity of 3.46 ft. per sec. Thus: compare 120 ft. of each, then 1 in 40 = 3 in 120, 1 in 30 = 4 in 120, and the flow will vary as  $\sqrt{3}$  to  $\sqrt{4} = 1.732$  to 2. Then

$$1.732 : 3 \text{ ft. per sec.} :: 2 : \frac{2 \times 3}{1.732} = 3.46 \text{ ft. per sec.}$$

Pneumatics relates to the properties, movements, and pressures of air and gases. Pure atmospheric air consists of

	By Weight.	By Volume.
Oxygen . . . . .	23·1	20·96
Nitrogen . . . . .	76·9	79·00

with traces of rarer gases. Atmospheric air also contains a small quantity of watery vapour. Roughly oxygen equals one-fifth of atmosphere, and nitrogen three-fifths. Vapour of water is an invisible gas five-eighths as dense as dry air at the same temperature and pressure. A constant impurity is carbon dioxide ( $\text{CO}_2$ ), given off by combustion and the breathing of men and animals, amounting to 0·04 per cent. Air, in common with all gases, is very compressible; approximately the volume is inversely as the pressure (known as Boyle's Law), that is, double the pressure and the volume is reduced to one-half, or allow it to expand to double the volume and the pressure will be one-half, and so on, in proportion. This is only true for real gases, not vapours like steam, where pressure causes more or less condensation. In exact work the rule also requires modification according to whether the temperature is maintained constant or otherwise. For instance, an *isothermal* expansion curve is produced if a constant temperature is maintained while a gas is expanding, and an *adiabatic* curve if the quantity of heat it contains is kept uniform. Air blowing off under pressure may produce ice, because the heat it contains having to fill a much larger space after expansion the temperature is correspondingly reduced. Gases which are chemically inert to each other diffuse or mix one with another in the inverse proportion to the square root of their density (Graham's Law). Hydrogen is taken as the unit. The following table shows density and  $\sqrt{\text{density}}$ , the latter giving the figures for comparison :—

Name.	Density.	$\sqrt{\text{Density}}$ .
Hydrogen . . . . .	1	1·00
Oxygen . . . . .	16	4·00
Nitrogen . . . . .	14	3·74
Carbon dioxide . . . . .	22	4·69
Atmospheric air . . . . .	14·5	3·81
Steam at 212° F. . . . .	9·2	3·03

Steam is colourless. What is commonly called steam, appearing as a white cloud or jet, is really minute particles of water condensed from the steam.

Gases flow through pipes more readily than water does, owing to the reduced specific gravity causing less friction.

The cubic feet delivered per hour = say,  $4000\sqrt{\frac{d^5}{l}}$ , where

$d$  = internal diameter of pipe in inches,  $l$  = length of pipe in yards. Charles' Law is that all gases expand equally by heating, and the volume varies directly as the absolute temperature ( $-459^\circ$  F. or  $-273^\circ$  C.). The temperature of a body is its thermal state, considered with reference to its power of communicating heat to other bodies, and is commonly called sensible heat. Heat itself consists of molecular vibration, and is thus called a mode of motion. Atoms are the ultimate constituents of matter, and these are variously combined into molecules to form different kinds of matter. In solids the molecules are relatively fixed, but in liquids they are constantly traversing the containing space, and thus two liquids in contact diffuse into each other very rapidly. In gases the molecules are mutually repulsive and tend to fly off in all directions.

#### EXAMINATION QUESTIONS RELATING TO CHAPTER I.

- ✓ 1.—What is the composition of (a) pure water; (b) ordinary atmospheric air?
- ✓ 2.—What is the weight of a gallon of water, and how many gallons are there in a cubic foot? What is the weight of a cubic foot of water?
- ✓ 3.—What will be the pressure on a surface 3 sq. in. in area under a head of water of 20 ft.?
- ✓ 4.—From the known weight of water and the facts that the atmosphere will sustain a column of water  $33\frac{1}{2}$  ft. high while it will only sustain a column of mercury 30 in. high, deduce the weight of a cubic foot of mercury and state its specific gravity.
- ✓ 5.—What do you understand by the term "water pressure"? What would be the total pressure at the bottom of an open tank, filled with cold water, 20 ft. long, 7 ft. 6 in. wide, and 3 ft. 9 in. deep?
- ✓ 6.—What would be the pressure of water in lb. per square inch at a tap 25 ft. below the cistern supplying it? State how concussion in pipes may be avoided.

7.—Calculate the possible standing pressure in lb. per square inch at the foot of a 4-in. vertical soil pipe 20 ft. high if it should get stopped up. Would a  $4\frac{1}{2}$ -in. set off in the pipe (swan-neck bend) make any difference in the pressure?

8.—What is "Torricelli's Theorem"? What will be the theoretical velocity of water issuing from an orifice 1 in. diameter with a head of 16 ft.?

9.—Explain the *vena contracta*, and give the coefficients of (a) contraction; (b) discharge; (c) velocity.

10.—What is understood by the term "*vena contracta*"? How and to what extent does it affect the flow of water from tanks?

11.—What is the fundamental formula for the velocity of water under a head of pressure; how is this modified according to the nature of the orifice through which the flow passes?

12.—If a 6-in. drain is running half full with a velocity of 4 ft. per second, how many gallons per minute will be discharged? In what diameters are cylindrical glazed stoneware pipes made?

13.—A given pipe fills a tank in 10 minutes, another takes 20 minutes to fill the same tank, how long will it take to fill it if both pipes are running together?

14.—State what data you require to determine the flow of water in a pipe, and show how you would calculate the flow.

15.—With a head of water of 20 ft. what quantity of water per minute would flow through a 3-in. straight pipe 1000 yds. long?

16.—Explain the terms "Hydraulic mean depth" and "Hydraulic gradient."

17.—What do you understand by the expression "Hydraulic mean depth," and how is it calculated?

18.—Give the meaning of the following, and explain their practical application in a system of water supply, viz.: (a) Hydraulic gradient; (b) Hydrostatic head; (c) "Loss of head" by friction in mains.

19.—State Graham's Law of the diffusion of gases.

20.—What is the relation between pressure and volume in the case of gases?

21.—Explain the difference between a vapour and a gas. Give examples of each.

22.—What are the relations between temperature, volume, and pressure in the case of a permanent gas? Why do the relations require modification in the case of vapours?

23.—The foot of the 4-in. soil pipe from an upstairs W.C. is stopped up, the head being 15 ft., what will be the pressure per square inch at the base and the total pressure?

24.—It is required to deliver 1 gallon of water per second through a pipe 150 yds. long, with a head of 72 ft., what diameter will be required? Show the working.

✓ 25.—What laws govern the diffusion of gases? What bearing have they upon the question of ventilation?

✓ 26.—If a bucket of water contains  $2\frac{1}{2}$  gallons, how many bucket-fuls will it require to charge 42 ft. of 4-in. drain?

✓ 27.—Two pipes respectively take 100 and 200 minutes to fill a tank 9 ft. by 6 ft. by 4 ft. How long will they take when both run together?

✓ 28.—What is the specific gravity of a substance, one cubic foot of which weighs 281.25 lb.? Show your calculations and give good reason for the method you adopt.

29.—What data are required to determine the rate of flow from a tank? Explain the formation of the *vena contracta*.

30.—What is meant by (a) pressure head; (b) velocity head; (c) friction head; (d) hydraulic gradient; (e) hydraulic mean depth?

✓ 31.—What is the pressure per square inch at the bottom of a vertical pipe 38 ft. high, filled with water? Does the diameter of the pipe make any difference?

32.—How do the following points affect the head of water required for a given flow? (a) diameter of pipe; (b) length of pipe; (c) roughness of pipe; (d) number of bends; (e) velocity in pipe.

33.—How many cubic feet of gas per hour could be supplied through 30 ft. of 1-in. pipe? Would this size be sufficient for 50 lights?

34.—A circular tank 4 ft. diameter has a hole 1 in. diameter at 6 ft. below the surface of the water, how long will the tank take to empty itself down to centre of hole? Coeff. .63.

35.—Water has to be diverted from a river through a 6-in. diameter pipe running at full bore at a velocity of 1 ft. per second to irrigate a field of 20 acres. How long will it take to deliver an inch of water over the whole area? What head will be required to produce this flow through a length of 500 yds.?

36.—What is meant by the hydraulic gradient along an undulating line of iron conduit piping, under pressure? Give sketch.

37.—What are the factors determining the flow of water through mains? Other things being equal, what effect upon the flow would be caused by doubling the head of water?

38.—How long would it take to fill a cistern holding 500 gallons, fixed at a height of 50 ft. above street main, by a  $\frac{3}{4}$ -in. service pipe, the pressure in the main being 30 lb. per square inch?

39.—A certain drain has a fall of 18 in. in a length of 64 ft. and the mean flow is at the rate of  $2\frac{1}{2}$  ft. per second, what would have been the rate of flow if the drain had been laid with a fall of 2 ft.?

40.—Explain the terms: cusecs, galmins, pressure head, hydraulic mean depth, hydraulic gradient, 37·29 O.D.

41.—Calculate how many minutes it will take to empty a 1000-gallon tank 8 ft. long by 6 ft. broad through a 3-in. diameter hole in the bottom, and show your working.

## CHAPTER II.

Porosity — Capillarity — Absorptivity — Permeability — Definition of vacuum—Action of siphon—Principle of suction—The construction of lift and force pumps—Centrifugal pumps and hydraulic rams.

POROSITY is that condition of a substance which, owing to minute spaces between the solid particles, enables it to allow liquids and gases to enter or pass through. This is also called the permeability of the substance. Absorptivity depends upon the same conditions, but relates rather to the power of holding liquids or gases. Capillarity is the power of small hair-like tubes or minute cracks to cause moisture to rise in them against the attraction of gravity and acts in conjunction with absorptivity. Cohesion is the attraction between particles of the same body, holding it together in one mass. Adhesion is the physical attraction of the particles of dissimilar bodies in opposition to the force of cohesion ; or that property by which one body remains in contact with another, either by the exclusion of air from closely fitting surfaces, or by the cementing properties of other substances interposed. In capillary attraction water and liquids that wet the tube are raised, mercury is depressed. Surface tension of liquids is that property which gives them the appearance of having an elastic skin at the surface of separation from a gas or from any other liquid, but no satisfactory explanation of its precise nature has been formulated. Impermeability is the reverse of permeability ; a bed of clay is impermeable.

A perfect vacuum is an empty space, but the difficulty of removing all the air or vapour renders this practically impossible to obtain. If the lower end of a pipe with the top closed and the air exhausted be dipped into water, the water will rise to a height not exceeding 34 ft., and generally not more than 24 or 26 ft., owing to the imperfection of the vacuum. It is

commonly stated that this action takes place by suction, but it is in reality the pressure of the atmosphere upon the outer surface of the water that forces it up the pipe, and all examples of so-called suction will be found of this character. A siphon (Fig. 2) is usually a pipe bent into two legs, the short one inserted into the receptacle to be emptied and the long one into the receiver. The siphon may be filled with water and the ends closed by the fingers before putting it in position when the liquid will start running. The pressure due to the atmosphere is equal at the extremity of each leg, and it is the extra weight of water in the long leg that causes the motion. Any tendency to a vacuum at the top of the bend is prevented by the pressure of the atmosphere on the surface of the water forcing it up the short leg. In large siphons air may collect at the bend and break the flow, which will not be resumed until the air is removed.

When a water- or sewer-pipe is carried down one bank under a stream and up the other side, it is called an inverted siphon, but it involves none of the properties of a siphon. It illustrates rather the statement that "water finds its own level," the pressure at one bank balancing the pressure at the other bank.

Pumps are machines for raising water. A common single-acting suction pump is shown diagrammatically in Fig. 3, where WL is the water level, SP the suction pipe, C the clack or suction valve, B the bucket or piston, D the delivery valve in the bucket, H the handle, F the fulcrum, PR the pump rod, S the spout. As the handle is lifted the piston is lowered, the suction valve closes, and the air in the pump barrel is compressed and passes out through the valve D. When the handle is depressed the bucket is lifted and the partial vacuum caused enables the atmospheric pressure to force the water up the suction pipe through the valve into the body or barrel of the pump. Upon raising the handle again, the bucket being pressed down upon the water, the latter passes through the delivery valve to the upper side of the bucket. The next time the handle is depressed this water is lifted and flows out of the spout. This pump may be converted into a lift pump by omitting the spout, closing the top of the pump, and providing a stuffing box and gland for the piston-rod to pass through without leakage, and adding a delivery pipe turned up from the side near the top of the pump. It will be seen that in this

case, when the bucket is lifted the whole column of water in the delivery pipe must be set in motion, making it very hard work. When the water is required to be lifted to a height, there are many different arrangements that may be adopted.

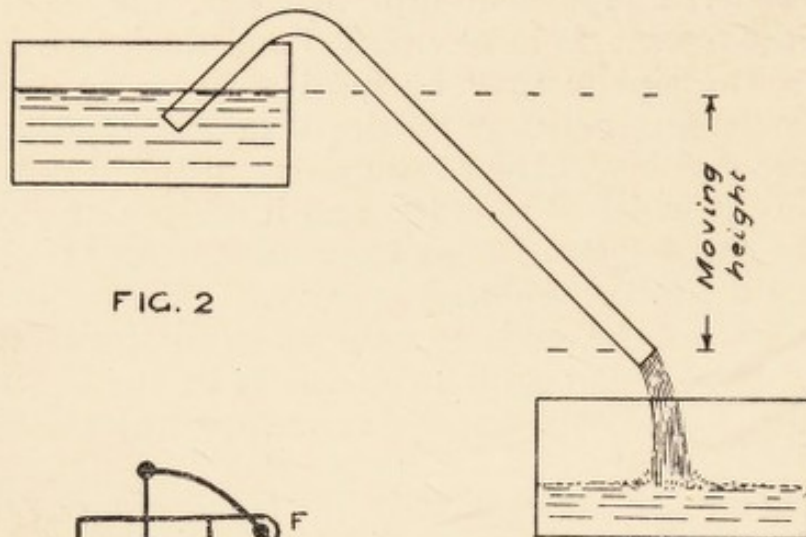

FIG. 2

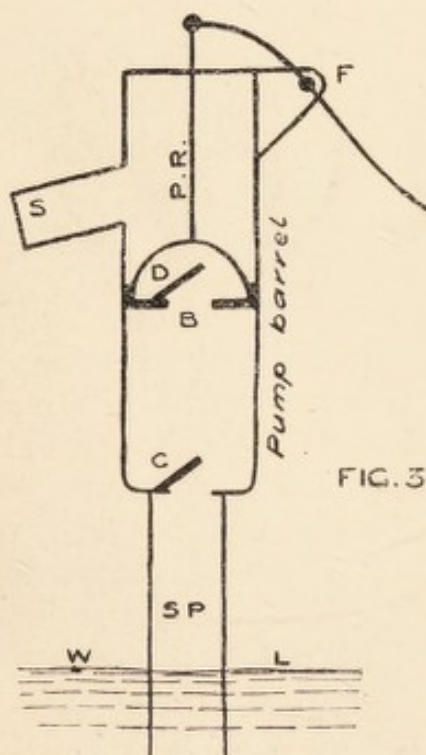

FIG. 3

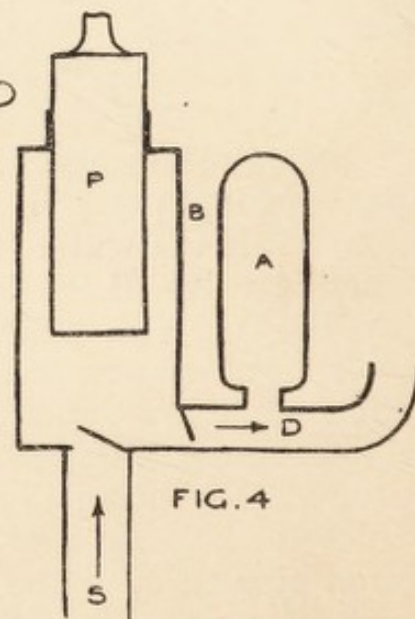

FIG. 4

FIG. 2.—Action of siphon.

FIG. 3.—Common suction pump.

FIG. 4.—Single-acting plunger pump.

Fig. 4 shows a single-acting plunger pump where P is the plunger or ram, B the body of the pump, S the suction pipe, and D the delivery pipe, each with its valve shown partly open. A is an air vessel on the delivery pipe to absorb the shock of sudden movement and render the flow of water more con-

tinuous. Instead of the water in the delivery pipe being set into sudden motion, the first movement causes some to enter the air vessel and compresses the air in it, which expands again as the column of water is able to take up the movement. Cavitation in pumps is the leaving of a space as a partial vacuum when the water cannot follow up as fast as the piston moves, so that in the return stroke it strikes against the water and produces a shock.

An improved arrangement for lifting water to a considerable height or forcing it under pressure, consists of the double-acting bucket and plunger, or piston and ram, pump shown in Fig. 5. In this case R is the ram, P the piston, B the body of the pump, S the suction, D the delivery, A the air vessel,

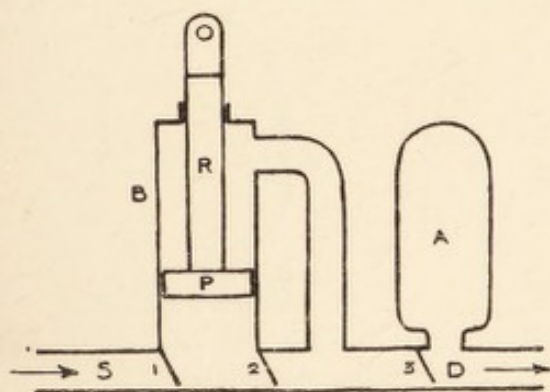

FIG. 5.—Double-acting bucket and plunger pump.

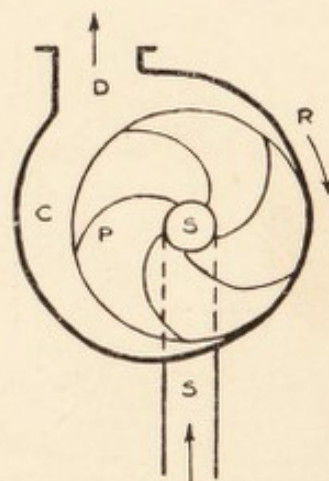

FIG. 6.—Centrifugal pump.

and 1, 2, 3 the valves. The ram has half the sectional area of the piston. When the piston is lifted the whole of the body of the pump is filled with water through valve 1, when it comes down again this water is forced through valve 2, half of it going through valve 3 past the air vessel, and the other half filling the annular space round the ram. In the next upstroke this water also goes through valve 3; the flow of water is by this means rendered almost continuous.

These are all called reciprocating pumps, because they have a single direct and reverse movement. Centrifugal pumps, on the other hand, have a continuous movement of rotation in one direction and a continuous flow. The common form, shown in Fig. 6, is only adapted for short lifts. The suction SS comes up the back of the pump casing C, P is the pump,

and D the delivery pipe. The curved blades throw out the water radially by centrifugal force, R being the direction of rotation, which is given to the pump by gearing or belting.

The hydraulic ram is another apparatus for lifting water, the principle of which is shown in Fig. 7. The air in the upper part of the air chamber D is normally compressed to a pressure equivalent to the static head exerted on it by the column of water in the rising main, while the dash or waste valve B is loose, and so supported that when hanging naturally there is a free outlet for the water from the lower part of the apparatus E. When the water is admitted to the drive pipe A, and reaches the bottom E, it first runs to waste through the outlet B, but its velocity gradually increases until it is sufficient to carry up

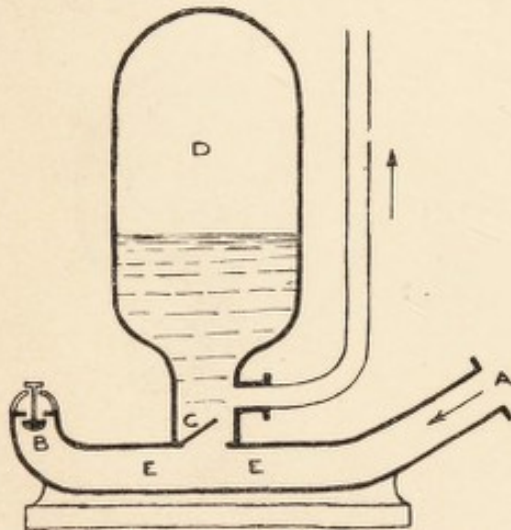

FIG. 7.—Simple hydraulic ram for lifting water.

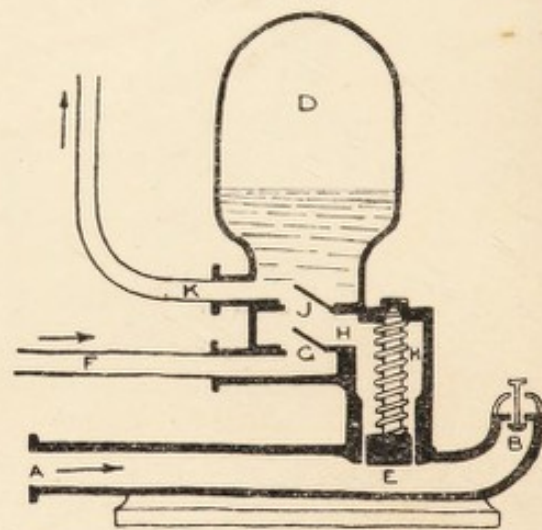

FIG. 8.—Hydraulic ram worked by impure water.

the valve and thus close the outlet. The momentum of the water in the drive pipe being thus suddenly arrested, causes an increase of the pressure in the chamber D; consequently, valve C opens and a portion of the water rushes into the chamber. This, however, relieves the pressure in the pipe E, and as soon as it falls to below that in the chamber the valve C closes again, imprisoning the water. The air in the chamber is compressed by the incoming water to an extent sufficient to provide space for its reception, but as the pressure in the chamber then exceeds that due to the head of water in the open topped rising main, the surplus water is forced out through this pipe, while the air expands again to its previous condition. At the same time as the reduction of pressure in E causes valve C to

close it allows valve B to open, when the water again runs to waste until it acquires sufficient velocity to recommence the sequence of operations. This does not act at all by suction, as it requires a head of water of not less than 18 inches flowing down the drive pipe.

Another form of hydraulic ram (Fig. 8) can be worked by impure water from a stream to raise pure water to the top of a building. It works upon the same general principle as the single ram, as will be seen by inspection of the diagrams. The ram must be placed at such a level that the water to be lifted is slightly above the working parts of the ram, when it will flow by gravity through the suction pipe F, lift up the valve G, and fill chamber H. The sudden arrestment, by the closing of the dash valve B, of the flow of the impure water passing through the drive pipe A will create momentary pressure at E, which will force upwards the piston at that point. The effect of this is to reduce the capacity of the chamber H, and to drive out some of the water contained therein, which automatically closes valve G and, opening valve J, passes thence into the air chamber D and compresses the air which, upon expansion, forces the water up the rising main K. As soon as the pressure falls in the drive pipe, the spring in chamber H pushes the piston E down to its original position, when fresh water flows in from the suction pipe to refill chamber H, and the apparatus is ready for the next stroke. The usual proportions for an ordinary hydraulic ram are as follows: Length of drive pipe should equal head of water in delivery pipe, with 1 ft. fall between mouth of drive pipe and escape valve for each 10 ft. lift.

D = diameter of drive pipe in inches.

$d$  = " " rising main in inches.

$f$  = fall of drive pipe in feet.

$h$  = height of lift in feet.

G = gallons per minute to work ram.

$g$  = " raised in 24 hours.

$$d = \frac{1}{2}D. \quad G = 3D^2. \quad g = 3000 D^2 \frac{f}{h}$$

## EXAMINATION QUESTIONS RELATING TO CHAPTER II.

1.—Explain the terms “porosity,” “absorption,” and “capilarity.”

2.—What is meant by the terms “permeable” and “impermeable”? Give examples illustrating each.

3.—What is meant by a vacuum? Describe, with an illustrative sketch, the action that takes place in the working of a siphon.

4.—Explain the principles underlying the action of a siphon.

5.—Describe the action of an ordinary siphon, also that of an “inverted siphon” carrying sewage under a river.

6.—Make a neat sketch and explain the action of a common suction pump.

7.—Explain the principle and construction of an ordinary lift and force pump, and describe its mode of working. State the conditions under which a lift pump can be used.

8.—Make a diagram showing the principle of a “double-acting force pump,” and explain how it acts.

9.—Describe a force pump, and sketch the gearing required for a deep well pump. Explain how boring for water is carried out.

10.—Sketch clearly a force pump and a hydraulic ram, and explain the action of each.

11.—Give a full detailed sketch of a hydraulic ram, and state the principles which are involved in its construction. With a fall of, say, 10 ft. to the ram, to what height can the water be raised, and what will be its probable proportion to the initial flow to the ram?

12.—Describe the hydraulic ram and its use in connection with the water supply in rural districts.

13.—Explain the working of a hydraulic ram. What quantity of water could be raised in 24 hours by a ram working under the following conditions, assuming that the drive and delivery pipe are suitable in every respect: water available, 25,000 gallons in 24 hours; working head, 14 ft. above ram; delivery, 200 ft. above ram.

14.—Sketch the action of a hydraulic ram worked by impure water but raising pure water.

15.—Describe experiments to show that air is a mixture and not a chemical compound.

16.—Under what conditions is it most advantageous to use (a) a ram; (b) a turbine; or (c) a water wheel, for lifting water from a stream to a storage tank for a domestic water supply?

17.—Explain the action of an ordinary suction pump. How many gallons of water would a pump, the barrel of which is 6 in. internal

diameter, the stroke being 9 in., working 20 strokes a minute, lift in half an hour?

18.—Describe a hydraulic ram and the principles involved in its construction. How is it used when there is a stream of suitable water passing down a valley? Say, with a fall of 12 ft. to the ram, to what height can the water be raised to a house on the hillside, and what will be the probable delivery to the house in proportion to the flow to the ram?

## CHAPTER III.

Production and transmission of heat, and effects of heat on solids, liquids, and gases.

HEAT and cold are comparative terms only, what is called cold has merely a lesser degree of heat. The sensation of  $\left\{ \begin{array}{l} \text{warmth} \\ \text{cold} \end{array} \right\}$

is produced by temperature  $\left\{ \begin{array}{l} \text{higher} \\ \text{lower} \end{array} \right\}$  than that of the body.

When a substance feels cold it is gaining heat from the hand, and when it feels hot it is losing heat, heat passing from one to the other until they are of equal temperature. Heat is produced by friction, the work done in moving a body against a resistance is converted into motion of the internal particles of the body, or, it is said, molar motion (or the motion of masses) is converted into molecular motion. Heat is also produced by combustion, which is generally due to the combination of oxygen with some other substance. Heat is transmitted by conduction, convection, and radiation. Conduction is the transmission of heat from particle to particle of a solid substance, or to and from substances in contact. Convection is the transfer and diffusion of heat by currents set up in a fluid, that is, a liquid or gas, so that the heat is carried by the motion of the particles of the fluid. The currents arise from the heat causing expansion of the particles receiving it, rendering them lighter and giving them a tendency to float in the general mass, colder particles coming in from below to take their place. Radiation is the propagation of heat waves in straight lines in all directions from the source, in the same manner and according to the same laws as rays of light, and the intensity, therefore, diminishes as the square of the distance from the source. The rays of heat pass through dry air without heating it until they fall upon some solid body which then heats the air by

contact. When air is moist it absorbs some of the radiant heat. Rays of heat are not visible, but their presence is indicated by personal feeling or by a thermometer. In the mercury thermometer, the expansion of the metal alongside a scale indicates the intensity of the heat. There are two forms in common use, the Fahrenheit and the Centigrade. The 0 or zero in the Fahrenheit scale was, at the time of its invention, supposed to be the greatest cold attainable, being obtained by a mixture of snow and salt. The boiling-point of water at sea level was marked 212, and the freezing-point of water then became 32. It is thus very unscientifically divided, but has been in use for so many years that people do not see the incongruity of such divisions. The Centigrade thermometer is based upon the two definite points in connection with water, 0 or zero for the freezing-point and 100 for the boiling-point. The 100 divisions between these are called degrees. Five degrees on the Centigrade scale correspond with nine degrees on the Fahrenheit scale, and to correct from one to the other

$$F.^{\circ} = \frac{9}{5}C.^{\circ} + 32, \quad C.^{\circ} = \frac{5(F.^{\circ} - 32)}{9}$$

but, as a student may get confused between the adding and subtracting 32, also the brackets in one case and not in the other, a simple rule to remember is: To the C.<sup>o</sup> or F.<sup>o</sup> add 40, multiply by  $\frac{5}{9}$  or  $\frac{9}{5}$ , as the case may be, and subtract 40. Thus, cast-iron melts at 2200° F. or  $(2200 + 40)\frac{5}{9} - 40 = 1204^{\circ}$  C. When the C.<sup>o</sup> are below zero the value of the minus sign must not be lost sight of; thus to convert  $-10^{\circ}$  C. to F.<sup>o</sup> we have  $-10 + 40 = 30$ ,  $\frac{9}{5}$  of 30 = 54,  $54 - 40 = 14^{\circ}$  F. The greatest degree of cold actually obtained (cold being merely absence of heat) by Professor Dewar, was  $-258^{\circ}$  C. or  $-258 + 40 = -218$ ,  $\frac{9}{5}$  of  $-218 = -392.4$ ,  $-392.4 - 40 = -432.4^{\circ}$  F. The absolute zero, or total absence of heat, is calculated to be  $-459^{\circ}$  F. or  $-273^{\circ}$  C., because gases at constant pressure expand  $\frac{1}{273}$  of their volume at 0° C. for each degree increase of temperature, or  $\frac{1}{490}$  of the volume for each degree increase of temperature from 32° F. Most materials expand on being heated; type metal and bismuth expand while solidifying, therefore, on the addition of heat, when they are on the point of becoming liquid they must contract. Water at 32° F. contracts by the addition of heat until 39.1° F. is reached.

The maximum density of water occurs at 39.1 F. = 4° C.,

which is one of the most important facts in nature. If water continued to get heavier as it got colder until ice was formed the ice would sink, and in the winter the lakes would be frozen solid, whereas after  $39.1^{\circ}$  F. is reached the water gets lighter and remains at the surface so that freezing has then to proceed downwards, and water absorbs or parts with heat very slowly by conduction, so that the freezing is delayed.

A simple experiment may be made to show the principle of deposition of dew. If a glass of cold water be brought into a living room it may shortly after be seen to be covered with moisture on the outside. For this to take place the water in the glass must be colder than the air of the room; there must be sufficient moisture in the air to allow the portion in contact with the glass to become over-saturated when cooled by the water in the glass; the dew-point is thus reached and moisture deposited. It is a common expression to say the dew is falling, but the dew is really deposited on the grass or other surfaces exactly in the same manner as on the glass.

The British Thermal Unit (B.Th.U. or  $\theta$ ) is the quantity of heat required to raise 1 lb. of pure water at the point of its maximum density ( $39.1^{\circ}$  F.) through  $1^{\circ}$  F.

By the Gas Act, 1920, a "therm" is the unit for the sale of gas = 100,000 B.Th.U. A cubic foot of coal gas varies in thermal value according to its quality, generally between 450 and 600 B.Th.U.

When water is raised from freezing,  $32^{\circ}$  F., to boiling-point,  $212^{\circ}$  F.,  $212 - 32 = 180$  B.Th.U.'s are absorbed per lb. of water, and if the heating be continued, it will require 966 B.Th.U.'s more to evaporate it into steam of the same temperature,  $212^{\circ}$  F. As all this additional heat is put in without raising the temperature, it is called "latent heat," but it is really converted into mechanical work in separating the molecules. In the same way the conversion of ice into water causes the disappearance of a quantity of heat equal to about 143 B.Th.U.'s with no rise in temperature.

The thermal capacity of any substance is the number of units of heat required to raise 1 lb. weight of the substance  $1^{\circ}$  F.

The specific heat of a body is its capacity for heat compared with that of an equal weight of water, and varies for different substances. The specific heat of various gases averages about 0.24, while steam is 0.48. The thermal units required to raise any body  $t^{\circ}$  in temperature = weight  $\times$  specific

heat  $\times t$ . Questions on specific heat occur as follows: Suppose a cast-iron ball, weighing 2 lb., at a temperature of  $800^{\circ}\text{F}$ . is dropped into 10 lb. water at a temperature of  $60^{\circ}\text{F}$ ., what will be the resulting temperature? (Specific heat of cast-iron, 0.1268.)

$$x = \frac{.1268 \times 2 \times 800 + 10 \times 60}{10 + .1268 \times 2} = 78.3^{\circ}\text{F}.$$

A mixture of 1 gallon of water at  $110^{\circ}\text{F}$ . with 3 gallons at  $60^{\circ}\text{F}$ . would result in a temperature of

$$\frac{1 \times 110 + 3 \times 60}{1 + 3} = 72.5^{\circ}\text{F}.$$

The difference between heat and temperature is that the former is the condition of the body with regard to its molecular vibration, while the latter is what may be called the sensible heat or the heat that may be felt. Clerk Maxwell's definition is, "The temperature of a body is its thermal state considered with reference to its power of communicating heat to other bodies."

The mechanical equivalent of heat (or Joule's equivalent) is, according to various authorities, from 772 to 778 foot-pounds for each British Thermal Unit. It was first measured by churning water mechanically and noting the rise of temperature.

The chief products from the combustion of coal are carbon dioxide and monoxide, water in the form of steam, nitrogen, etc. Theoretically, 10 lb. of air are required to burn 1 lb. of coal, but practically, from 15 to 16 lb. of air are necessary to allow for imperfect contact and other losses (13 cub. ft. air weigh 1 lb.).

#### EXAMINATION QUESTIONS RELATING TO CHAPTER III.

1.—What is a British Thermal Unit? State in what modes heat is transmitted, and give an example of each.

2.—What is meant by (a) sensible heat; (b) latent heat? How many heat units (B.Th.U.) are required to evaporate 1 cub. ft. of water from  $60^{\circ}\text{F}$ .?

3.—Show by a sketch the comparison between the divisions of a Fahrenheit and a Centigrade thermometer. Mark the figures on

each for freezing-point, point of maximum density, and boiling-point of water.

4.—If water expands  $\frac{1}{22}$  of its volume in being raised from  $32^{\circ}$  F. to  $212^{\circ}$  F., by how many cubic inches will a gallon of water increase in bulk between the same temperatures?

5.—At what temperature in  $F.^{\circ}$  is the maximum density of water? How does this affect the freezing of ponds?

6.—What are convection currents in a liquid, and how are they caused? Is there any corresponding motion in gases; if so, how is it generated and what is its effect on the atmosphere?

7.—Explain the principle of the thermometer. A Centigrade thermometer shows the temperature of a room to be 20 degrees. Express the corresponding reading on the Fahrenheit scale, and show how your result is obtained.

8.—What do you understand by "conduction" and "convection" respectively? How can convection currents in a liquid be demonstrated?

9.—(a) At what temperature does water boil at sea level? Give your answer in the Fahrenheit and Centigrade scales. (b) What connection is there between the boiling-point of a liquid and the pressure of the atmosphere? (c) Explain the conditions under which water will boil at  $185^{\circ}$  F.

10.—A bar of wrought iron at  $60^{\circ}$  F. measures exactly 10 ft. How long would it be at  $32^{\circ}$  C.? (Coefficient for each degree F.,  $\cdot 000012$ .) What is the use of this information in iron constructional works?

11.—Convert  $47^{\circ}$  F. into degrees Centigrade, and 38 mm. into inches (1 mm. =  $\cdot 03937$  in.). Explain the term "specific heat."

12.—What is meant by the coefficients of linear and of cubical expansion? Show how a knowledge of their values may have a practical application in sanitary work.

13.—What do you understand by latent heat? How many units of heat are required for changing ice into water and how many for changing water into steam?

14.—What is meant by specific heat? What bearing has the specific heat of water on the climate of seaside places?

15.—Show how much the temperature of 1 cub. ft. of air at  $60^{\circ}$  F. will be raised by the employment of 1 British thermal unit. (Note.—The specific heat of air at constant pressure is  $0\cdot 238$ .)

16.—What do you understand by the term "mechanical equivalent of heat"? Give a brief description of some of the ways in which its numerical value has been more or less accurately determined.

17.—Explain clearly in what way a thermometer indicates changes in temperature. How is it graduated? How would you test the accuracy of its graduation at freezing-point and boiling-point? Compare the various scales in use.

18.—Reduce to  $0^{\circ}$  C. and 760 mm., 80 c.c. of gas at  $8^{\circ}$  C. and 740 mm.

19.—Convert  $60^{\circ}$  F. to Centigrade units, and 760 mm. to inches. When are these quantities respectively used? What is the "specific heat" of water?

20.—How many units of heat will be required to raise 15 gallons of water from  $50^{\circ}$  F. to  $212^{\circ}$  F.?

21.—What is meant by "latent heat," and how is it measured?

22.—What are the natural sources of heat? What is the difference between heat and temperature? What is meant by absolute zero?

23.—Define the term "latent heat." How is latent heat utilized in connection with (a) disinfection; (b) refrigeration?

24.—What is meant by a thermal unit, a dynamic unit, a Board of Trade unit, and a unit of illumination?

25.—How many units of heat are given out by the condensation of 1 cub. ft. of steam at atmospheric pressure?

26.—What are meant by (a) relative conductivity; (b) convection currents; (c) evaporative efficiency; (d) horse-power?

## CHAPTER IV.

## Elementary chemistry.

THE chemist, by analysis, separates compound bodies into their constituents, and when he has finished all he can do he finds less than 100 different kinds of substances in the universe, whether solid, liquid, or gaseous. We cannot go on dividing a substance to infinity, the smallest portion which retains the characteristics of the bulk is called a particle, but this may be made up of several molecules, and such molecules may be made up of several atoms. The atoms are the ultimate indivisible portions of matter, probably spherical and less than the one-hundred-millionth of an inch in diameter; their various grouping in molecules produces all the different kinds of matter that we know of. A chemical element, such as carbon, oxygen, iron, is one that is reduced to its simplest condition, and cannot, at present, be separated into any other forms of matter. A chemical compound, such as water, lime, sugar, consists of more than one form of matter, and can be reduced by analysis into its components. For example, water ( $\text{H}_2\text{O}$ ) consists of two volumes of hydrogen to one of oxygen and is a chemical compound. Air consists of 21 parts oxygen to 79 nitrogen, and is a mechanical mixture. Chemical combinations take place in definite proportions in all cases; they may be simple, as in water ( $\text{H}_2\text{O}$ ), or more complex, as in red lead ( $\text{Pb}_3\text{O}_4$ ), or mixed, as in clay  $(\text{Al}_2\text{O}_3)x + (\text{SiO}_2)y + (\text{H}_2\text{O})z$ . Other compounds useful to know are, carbonate of lime,  $\text{CaCO}_3$ ; carbolic acid (phenol),  $\text{C}_6\text{H}_5\text{OH}$ ; plaster of Paris,  $\text{CaSO}_4 + 2\text{H}_2\text{O}$ , the latter being driven off in calcining; white lead  $2\text{PbCO}_3$ ; litharge,  $\text{PbO}$ .

As examples of chemical transformations, we may take—

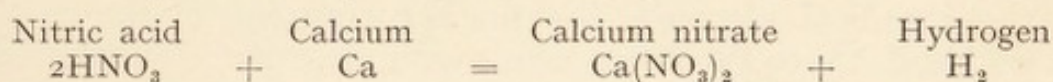
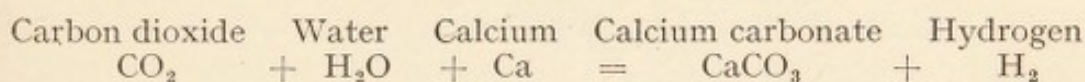
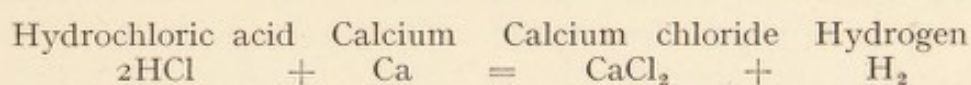
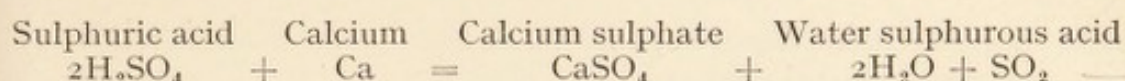

Hard water holds carbonate of lime in solution when there is an excess of carbon dioxide, but the latter is driven off in boiling and the calcium carbonate is precipitated, thus :—

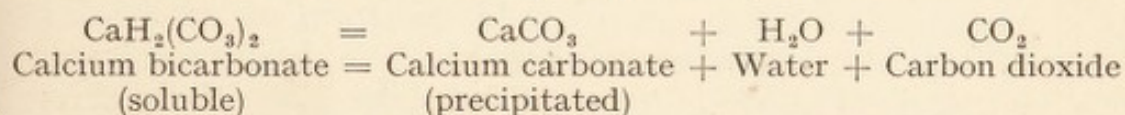

The carbonate of lime may also be precipitated by adding more lime, thus—

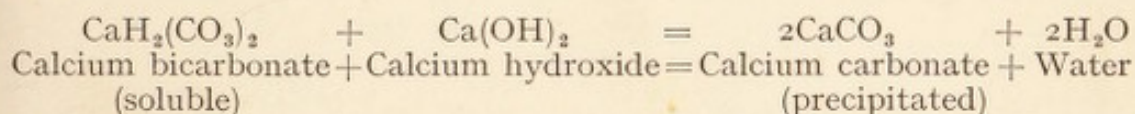

Water containing sulphate of lime may be softened for use in boilers, but not for drinking, by adding washing soda, thus—

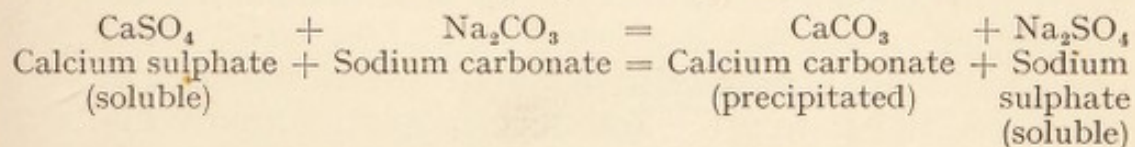

The reason the water cannot be used for drinking, although softened, is that the sulphate of soda produced is an opening medicine. Evaporation and re-distillation will remove the hardness of water from whatever source it may arise, because the salts will in every case be left behind, and only pure water in the form of steam passes over.

When water is poured upon freshly-burnt lime (quicklime) slaking takes place, more or less violently according to the purity of the lime, and hydrate of lime is produced,  $\text{CaO} + \text{H}_2\text{O}$ , which, left to itself, absorbs carbon dioxide from the air and becomes  $\text{CaCO}_3 + \text{H}_2\text{O}$ . Iron rust is another instance of chemical action. The iron in moist air is attacked by carbon dioxide, and a coating of carbonate of iron is formed which is converted to rust by absorbing oxygen. The carbon dioxide is thus liberated

and again attacks the iron, and so it goes on. Chemically rust is a hydrated sesquioxide of iron  $2(\text{Fe}_2\text{O}_3)\cdot 3\text{H}_2\text{O}$ . The chemical elements are supposed by some to be different kinds of atoms, and that is the popular view. Others consider that there is only one kind of atom (or ultimate form of matter), and that the mode of combination into molecules determines the nature of the chemical element, the further grouping of the molecules giving rise to the different compounds. Some substances exist under more than one form, for instance, carbon occurs as diamond, graphite or black-lead, charcoal and lamp-black.

An acid is a substance containing hydrogen, which hydrogen may be replaced by a metal (or group of elements equivalent to a metal) when presented to it in the form of an oxide or hydrate. A base is a substance capable of replacing the hydrogen, as described above. An alkali is a base of specially active character, soluble in water, to which it imparts generally a soapy taste and touch. A salt is the body produced when an acid and base react upon each other, for example—

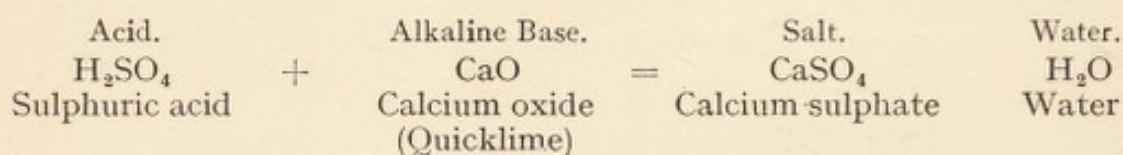

Acids will redden blue litmus paper, and alkalies restore the blue colour.

The essential properties of matter are impenetrability, extension, and form; the accessory properties are divisibility, flexibility, tenacity, or toughness, brittleness, elasticity, malleability, ductility, hardness; and the accidental properties colour, taste, smell. The conditions of matter are solid, viscous, liquid, and gaseous, depending largely on temperature. Sir William Crookes formulated another condition, that of ultra-gaseous or radiant matter. Solution in water is merely a mechanical mixture, because by evaporation of the water the substance is left behind in its original condition. In the case of a powdered salt being dissolved in water, evaporation may leave the salt behind as crystals of regular form, but that does not alter its constitution. When an insoluble salt is formed by chemical reactions it is precipitated, but a soluble salt remains in solution until the liquid is saturated, when the remainder is precipitated. Substances in a liquid form are either of a crystalline or a colloidal character. Colloid sub-

stances are those like gelatine, glue, or jelly, which will not crystallise. They have a very large surface area per unit of weight. They are soluble in water and slowly diffusible. They may be separated in a mixed solution of colloid and crystalline substances by the latter filtering off through membrane or parchment while the former remain. Colloidal matters are formed in the purification of sewage and are found rather troublesome to dispose of. Some substances dissolve much more rapidly in hot water than in cold, while with others there is little difference in the effect of the temperature. Some substances are very sparingly soluble, such as lime,  $\text{CaO}$ , potassium chlorate,  $\text{KClO}_3$ , mercury perchloride,  $\text{HgCl}_2$ , etc., while others are very freely soluble, such as common salt (sodium chloride  $\text{NaCl}$ ), sugar, calcium chloride,  $\text{CaCl}_2$ , etc. All freely soluble substances are deliquescent, that is, they readily absorb moisture from the air.

A pound of water contains four times as much oxygen as a pound of air, thus:  $\text{Water} = \text{H}_2\text{O}$ . Atomic weights,  $\text{H} = 1$ ,  $\text{O} = 16$ , therefore 18 lb. water contains 16 lb. oxygen, or there will be  $\frac{16}{18} = \frac{8}{9}$  lb. O in 1 lb. water. Air approximately = 4 parts N to 1 part O. Atomic weights,  $\text{N} = 14$ ,  $\text{O} = 16$ , then, by weight we have  $4 \times 14 + 1 \times 16 = 72$ , of which 16 will be oxygen, and there will be  $\frac{16}{72} = \frac{2}{9}$  lb. O in 1 lb. air.

In taking a sample of water for analysis, three "Winchester quart" bottles (each holding three pints) should be employed. They should be sterilised before use by being filled with hot water, which is then gradually raised to the boiling-point, emptied, and the stoppers inserted, until being filled with the sample to be tested. They should then be rinsed out two or three times with the water to be tested and filled by plunging the mouth below the surface. The water should be within  $\frac{1}{16}$  inch of the underside of the stopper. The stoppers should then be covered with a thin leather cap tied on with string and sealed with sealing-wax. A label with full particulars and date should be tied round each bottle, one sent to an analyst, another to a bacteriologist, and the third to be retained.

Electrolysis is the decomposition of a compound body into its constituent parts by means of electricity. The separation of water into its components oxygen and hydrogen by means of a galvanic battery is called electrolysis. Severe corrosion of metal may occur by electrolytic action through the passage of only a small current.

## EXAMINATION QUESTIONS RELATING TO CHAPTER IV.

- 1.—State what is meant by (a) a chemical compound; (b) a mechanical mixture, and give two examples of each.
- 2.—Explain what is meant by (a) a chemical element; (b) a chemical compound; (c) a mechanical mixture. Give examples.
- 3.—What are the chief properties of (a) acids; (b) alkalies; (c) bases? Give an example of each.
- 4.—Group the following under the headings of (a) chemical compounds; (b) mechanical mixtures: atmospheric air, water, lime, concrete, plumbers' solder, glaziers' putty; and state their composition.
- 5.—Under what conditions is carbon-monoxide gas sometimes found in the air of inhabited places? What is known about the physiological effects of this gas on human beings?
- 6.—What gases or vapours are given off by the combustion of (1) pure hydrogen; (2) coal gas; (3) charcoal or coke?
- 7.—Describe the difference between carbonic acid and carbonic oxide, and state how these gases are produced, and their respective effects on human life. What are the modern chemical names of these gases?
- 8.—What is the composition of (a) lime; (b) plaster of Paris; (c) Portland cement?
- 9.—Briefly describe the atomic theory and state what is meant by "combining proportions."
- 10.—Describe the difference between crystalline and colloid substances.
- 11.—Describe the changes that take place when sulphuric acid is added to scraps of iron.
- 12.—Why are some salts precipitated in water and others held in solution? Give some examples.
- 13.—Describe carefully how you would take a sample of water for analysis.
- 14.—How would you obtain and transmit a sample of well water for: (a) chemical analysis; (b) bacteriological examination? What detail would you consider it advisable to send with the samples?
- 15.—What is meant by electrolysis? Give an example.
- 16.—What is the chemical composition of the following materials: Freshly burned lime, plaster of Paris, rock asphalte, red lead, and white lead?
- 17.—What chemical elements enter into the composition of cast-iron?
- 18.—State what you know of the chemical composition of (1) lime; (2) Portland cement? In slaking lime what chemical action occurs?

## CHAPTER V.

Meteorological instruments—Their construction, adjustment, and reading.

METEOROLOGY deals with climate and weather. Meteorological stations are instituted at the Observatories in England and at many seaside and other places. They should be provided with at least a Stevenson Thermometer Screen (a wooden box with louvered sides 4 feet above the ground), containing dry bulb, wet bulb, maximum and minimum thermometers; also a rain-gauge, sunshine recorder, and recording barometer. The thermometers consist of a fine glass tube with a bulb at one end containing mercury or alcohol. The liquid expands on heating and contracts on cooling; a scale printed or engraved alongside or etched on the glass indicates the temperature then existing. A maximum thermometer has a small portion of the mercurial column separated from the remainder by a minute air-bubble; this is pushed onwards by expansion, but as the temperature falls it is left behind, the instrument being horizontal, so that the maximum temperature since the last reading is indicated. It can be reset by holding the bulb downwards. The minimum thermometer is charged with alcohol and a short pin having a head at each end. When the temperature falls the spirit draws the pin along with it, but on rising again the spirit passes the pin, which is left behind to indicate the lowest point reached. When the bulb is raised the pin slides along until the end again touches the end of the spirit column. The dry and wet bulb thermometers are generally mounted on the same frame (Fig. 9); they require a rather more extended description because of their application in the house. The ordinary dry bulb thermometer giving the temperature is not sufficient to indicate the feeling of comfort or otherwise that should be experienced at that temperature, because so much depends upon the amount of moisture in the air. This is called its

humidity, and may be measured indirectly by means of a wet bulb thermometer, which is an ordinary thermometer with

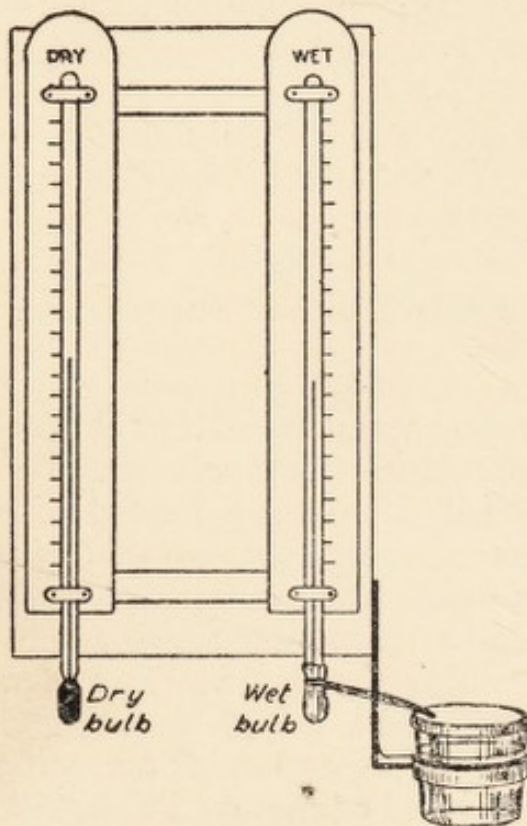

FIG. 9.—Dry and wet bulb thermometers.

the bulb projecting below the wood or metal backing and having a piece of muslin tied round it with a piece of lamp cotton dipping into a small cup of water. The water rises in the cotton and keeps the muslin moist. The drier the air, the quicker the moisture will evaporate from the muslin, and reduce the indication of the thermometer by the absorption of latent heat, showing a lower result than a dry bulb thermometer alongside. If the air is very damp and saturated with moisture no evaporation will take place and both thermometers will indicate alike. The term relative humidity is applied to the proportion of moisture in the air compared with complete saturation,

stated as a percentage. The following table will enable the relative humidity to be determined from the indications of a compound dry and wet bulb thermometer :—

Dry Thermometer.	Difference between Dry and Wet Thermometer F.°							
	1	2	3	4	5	6	7	8
F.°	Relative Humidity, Saturation being 100.							
40	92	84	76	68	60	53	45	38
50	93	87	80	74	67	61	55	50
60	94	89	84	78	73	68	63	58
70	95	91	86	81	77	72	68	64

The most suitable temperature in a room is on the average 60° F., but at the same time the wet bulb thermometer should

indicate  $55\text{--}56^\circ\text{F.}$ , or a little more, if the air is in motion. The dew-point, or point at which the atmosphere is fully charged with vapour and begins to deposit it, varies with the temperature. Approximately the indication of the dry bulb minus twice the difference of dry and wet bulb will give the temperature of the dew-point. The general temperature of England is higher than that of other countries of the same latitude, because the warm Gulf Stream, from the Gulf of Mexico, sets towards the coast of England. For the same reason, the south-west winds, being loaded with water vapour, deposit it as rain when they reach the high lands in the west and north-west of England.

The rain-gauge (Fig. 10) is an appliance for measuring the local rainfall. It is made of

sheet copper with a circular funnel, either 5 ins. or 8 ins. diameter. The Snowdon pattern has a deep rim to retain snow. The rim should be 1 ft. above ground level, in an open situation, the lower end being partially sunk in the ground to steady it. Below the funnel a bottle is placed to receive the water, which can be removed and emptied into a glass measure divided to show the rainfall to hundredths of an inch in depth. The 5-inch gauge has an area of 20 sq. ins., and the 8-inch has 50 sq. ins. Suppose the measure to be 2 ins. diameter, then the divisions will be  $\frac{5}{2} \times \frac{1}{100} = \frac{1}{8}$  inch apart for  $\frac{1}{100}$  inch rainfall, and for  $\frac{1}{10}$  inch rainfall  $\frac{5}{8}$  inch apart. The gauge is examined daily at 9 a.m., and any snow therein melted for measurement. The small fall of even  $\frac{1}{10}$  inch is equal to 10 tons per acre

$$= \frac{\frac{1}{10} \times 43560 \text{ sq. ft. in acre}}{12 \text{ ins. in foot.}} \times \frac{62\frac{1}{2} \text{ lb. in cub. ft.}}{2240 \text{ lb. in ton.}} = 10.128 \text{ tons.}$$

A knowledge of the local rainfall over a series of years is essential in designing water and sewerage schemes and for many other purposes.

The sunshine recorder should be of the Campbell-Stokes

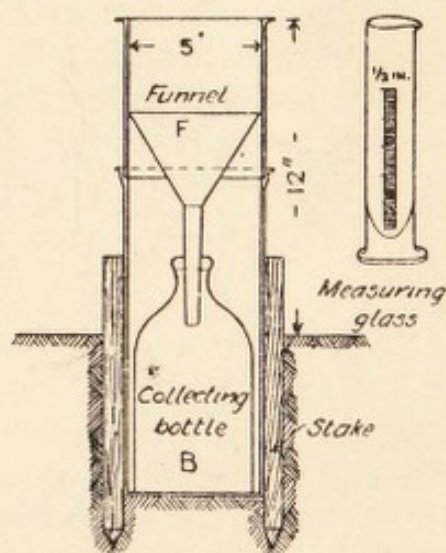

FIG. 10.—Section through rain gauge fixed in position.

pattern (Fig. 11), consisting of a solid glass ball 4 ins. diameter, supported in a metal frame. A bent card being placed behind the ball the sun is focussed on it and burns its own record; a scale applied enables the duration in hours to be measured.

The barometer is really used for measuring the weight of the atmosphere, although popularly it is supposed only to indicate the weather, which it does not do at all; it is only by inference from the changes of the barometric pressure that the weather is foretold. Dry air is heavier than moist air, because the vapour of water is lighter than the atmosphere which holds it. A cubic foot of dry air weighs  $\cdot 077$  lb. When the barometer is high or rising, fine weather is expected, and when low or falling, wet weather may be looked for. The following couplets may be noted in connection with barometric indications of the weather:—

Long foretold, long last,  
Short notice, soon past.

First rise after low  
Foretells stronger blow.

also,

Red sky at night is the shepherd's delight,  
Red sky in the morning is the shepherd's warning;

the one indicates probable fine weather the next day and the other bad weather.

For navigation purposes it is desirable to have records transmitted daily, or oftener, from several distant places to one centre so that the isobars, or lines of equal pressure, and the direction and force of the wind may be plotted and the probable future conditions estimated 24 hours ahead. When the isobars, or lines of equal pressure, are plotted on a map it will be seen at once where the pressure is highest or lowest. The areas of high pressure are called "anti-cyclones," and those of low pressure "cyclones." When the direction of the wind is plotted by arrows on the same map it will be seen that it blows parallel with the isobars, that is, generally in large circles. Round the areas of high pressure they move in the direction of the hands of a watch, and round the areas of low pressure in the reverse direction.

American wind engines or windmills are so often used in small pumping installations that some knowledge of the wind is necessary. The direction can be observed by watching smoke from a chimney, or a flag on a staff, or a weather vane on a church, but to measure the velocity an anemometer is required. The most usual is Robinson's Cup Anemometer (Fig. 12), consisting of four hemispherical cups at the end of horizontal arms rotating on a vertical spindle upon which is an endless screw that gives motion to a series of wheels. If the apparatus is suitably arranged, a continuous record of the wind can be taken. Approximately, the wind travels two to three times faster than the cups, and allowance has to be made for

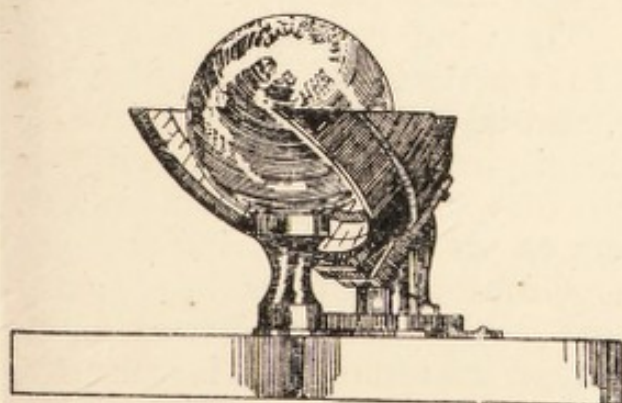

FIG. 11.—Campbell-Stokes sunshine recorder.

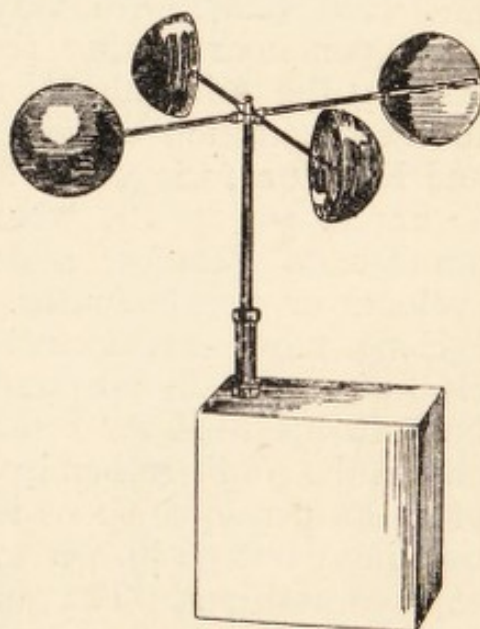

FIG. 12.—Robinson's cup anemometer.

this. It was usual to assume that the actual velocity of the wind was three times the velocity of the revolving cups, but in 1902 it was proved that the correct coefficient is 2.2. The corresponding pressure has been found by Dr. T. E. Stanton to be  $P = .0031 V^2$ , where  $P =$  lb. per sq. ft.  $V =$  miles per hour. Maximum mean wind velocity British Isles = 75 m.p.h., but the maximum velocity in gusts may reach 100 m.p.h., which would give a pressure of 31 lb. square foot. The variation in barometric pressure is due to the wind and the amount of watery vapour. The prevailing wind in England blows from the south-west, and generally brings rain, owing to the amount of moisture it carries from the hotter parts of the Atlantic

Ocean. If a compass card be divided into angles of 45 degrees, and the daily direction of the wind plotted by pricking off, say,  $\frac{1}{16}$  inch along the corresponding line, by the end of the year it will show us what is called a "windstar" (Fig. 13), which is an actual record, the amount of projection in any direction giving the proportion of wind from that quarter. It will be observed that it blows twice as often from the south-west as from any other point. The circle in the centre shows by its radius to the same scale the number of calm days in the year, the distances being pricked off on one of the lines radiating from the centre. The figures on the outer circle show the number of days in the year the wind blew from that direction. The wind blows with varying force, but averages about 12 miles per hour during the year. The Beaufort wind scale used by the Admiralty is numbered from 1 to 12, according to the description of wind, No. 1 being scarcely perceptible and No. 12 a furious hurricane. The numbering is such that  $V$  m.p.h. =  $1.87 B^{\frac{3}{2}}$ , where  $V$  = miles per hour and  $B$  = number on Beaufort scale. The wind commonly moves in cyclones or circular paths. In the northern hemisphere the cyclones move anti-clockwise, and in the southern hemisphere clockwise. In the northern hemisphere if one stands with his back to the wind the centre of the storm will be on his left, and in the southern hemisphere on his right. A wind pressure of 30 lb. per square foot is sufficient to allow for in ordinary buildings, but 56 lb. per square foot should be allowed for in exposed positions. The pressure of the atmosphere is measured by a barometer. To a novice a barometer at first sight looks like an overgrown thermometer. It consists of a tube about  $\frac{1}{4}$  in. bore and 3 ft. long, the top end closed and the bottom turned up and terminated with a reservoir of mercury, upon the surface of which the atmospheric pressure acts. The tube being filled with mercury and held upright, a vacuum forms in the upper part and the mercury falls to give a difference of level inside and outside of, say, 30 ins., according to the pressure of the atmosphere at the time. The specific gravity of mercury is 13.6, and a column 30 ins. high therefore corresponds to  $\frac{30 \times 13.6}{12} = 34$  ft. of water. A good barometer has a scale alongside the tube, divided into inches and tenths, and by means of a sliding vernier the reading may be taken to

hundredths of an inch. This is shown in Fig. 14, where the reading is 30.07 ins. The principle of the vernier is that a length equal to 9 divisions on the scale is divided into 10 divisions on the vernier, so that each is one-tenth smaller than on the scale, and the fraction of a tenth is given by the position of those lines that coincide. Mercury barometer readings decrease approximately 1 in. for every 1000 ft. altitude above sea level. The Fortin barometer is a standard barometer reading to  $\frac{1}{5000}$  or  $\frac{1}{10000}$  in., but is not sufficiently distributed to warrant a detailed description here. An aneroid barometer, has no mercury. Two circular discs with annular corrugations are joined round the edges, and bent up in the shape of a double-convex lens with air space inside. One part is attached to the

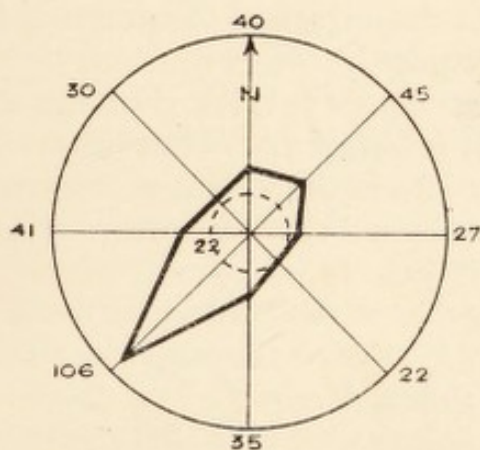

FIG. 13.—“Windstar.”

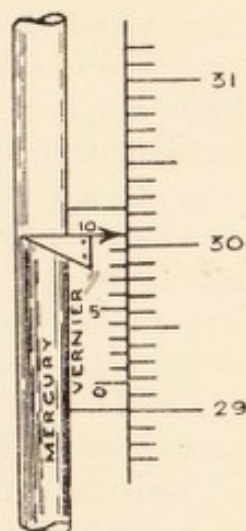

FIG. 14.—Vernier on barometer.

box while to the other part gearing is attached so that the movement caused by variations in the pressure of the atmosphere is transmitted to a pointer on the outer dial face working over a circular scale marked in inches and tenths. In household barometers the scale is also marked to indicate probable weather. Below 28 is marked Stormy, between 28 and 29 Rain, between 29 and 30 Change, between 30 and 31 Fair, beyond 31 Very dry. A surveyor's aneroid has fine divisions, and an additional scale marked in feet and fractions, for reading the height of the observer above sea level. A difference of level of 5 ft. may be read off from a good aneroid.

A curious fact arises out of the reduced atmospheric pressure

on high mountains. At a height of 10,000 ft. water boils at  $193^{\circ}$  F.; this is not sufficient heat to make an infusion of tea, so that if tea were required at such a height it must be taken up in a thermos flask. Water may be said to boil when ebullition takes place owing to the rising of steam through the water, and this may happen at very low temperatures if a vacuum can be maintained in the vessel.

#### EXAMINATION QUESTIONS RELATING TO CHAPTER V.

1.—Describe and sketch a rain-gauge. State how it should be placed, the method of taking the readings, and the purposes for which a knowledge of the rainfall is required.

2.—What is meant by water vapour? How does the amount of vapour in the atmosphere affect its weight? What instruments may be used (*a*) to indicate the variations in the weight of the atmosphere; and (*b*) to estimate its relative humidity? In what terms are the readings of these instruments recorded?

3.—In what manner is atmospheric pressure determined, and why does it vary at different altitudes? How is the weight of air measured, and what does a cubic foot of air weigh?

4.—Is it strictly accurate to say that dew *falls*, mist *rises*, fog *descends*, and clouds *arise*? Justify the expressions which you think are accurate, substitute correct expressions for such as you think inexact, and give reasons for your answers.

5.—What circumstances influence the mean annual temperature of a country? How does the variation in temperature, and the amount of aqueous vapour in the air influence the barometer? How is the amount of aqueous vapour determined, and how is it usually expressed?

6.—Describe the construction of a mercurial barometer. To what height will the pressure of the atmosphere support a column of water?

7.—What are the several natural phenomena associated with the presence of water vapour in the atmosphere? Describe the conditions under which each occurs.

8.—Give the composition of atmosphere in its natural state. What are the chief gaseous impurities found in the air in manufacturing towns?

- 9.—What is an "isobar"? What are "isobaric lines"?
- 10.—Why is the climate of England more genial and less variable than that of Central Europe, although the latter is at a lower latitude? Why is it colder on the top of a mountain, although it is nearer to the sun?
- 11.—What is meant by the terms "cyclone," "anti-cyclone," "humidity," "vacuum," and "true north"?
- 12.—Describe the following instruments and state what precautions, if any, would be necessary in determining the position in which they should be placed; (a) rain-gauge; (b) a sunshine recorder.
- 13.—What is the composition of the atmosphere? What advantage is there in knowing this? Is the composition the same under all conditions? State some of the causes which alter the normal conditions.
- 14.—What is meant by "dew-point," and what circumstances influence its temperature?
- 15.—What is meant by a prevailing wind? What is the prevailing wind in England? How are "wind stars" constructed?
- 16.—How is the velocity of the wind ascertained, and how is the pressure determined from the velocity?
- 17.—Sketch a mercurial barometer and explain its action.
- 18.—Explain the process of (a) evaporation; (b) ebullition.
- 19.—Describe a sunshine recorder. Is its action affected by the alteration of our hours to "summer time"?
- 20.—Sketch and describe the apparatus used for determining the velocity of the wind. How is the pressure obtained from the velocity?
- 21.—What circumstances influence the mean annual temperature of a country? How does the variation in amount of aqueous vapour in the air affect the barometer? How is this aqueous vapour determined, and how is it usually expressed?
- 22.—Sketch and describe a wet and dry bulb thermometer. What information can you gather from the two indications?
- 23.—How is a fall of snow measured and converted into terms of rainfall? How is a rain-gauge adapted to receive snow?
- 24.—Describe the fitting up of a meteorological station, and sketch a ground plan, showing the position of the various details.
- 25.—Define the following terms: "relative humidity," "absolute humidity," "cyclones," "anti-cyclones," "V-shaped depressions," "cols," "wedge-shaped isobars," "straight isobars."
- 26.—Describe, with sketch, the re-filling of the common type of bent barometer tube having a mercury cistern, when it has accidentally lost some of its vacuum.

27.—With an annual rainfall of 30 ins. and a collecting area of 1200 sq. ft., what capacity of tank, in gallons, would hold a week's average rainfall?

28.—What are the prevailing winds in England, and why should they come from a particular direction?

29.—Give some figures relating to the rainfall in different parts of England. State some of the causes for difference of rainfall.

SECTION II.  
LOCAL CONDITIONS.

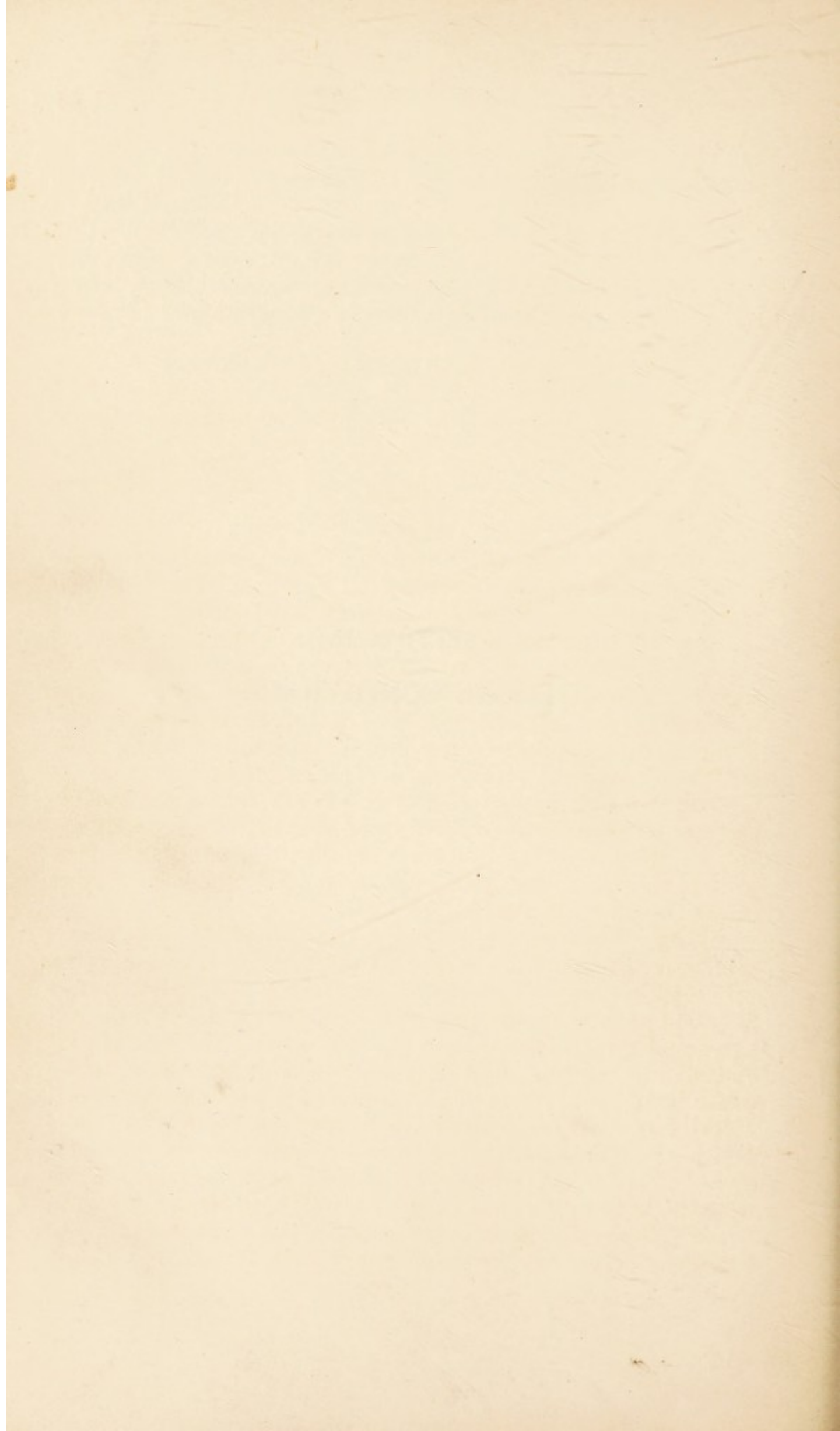

## CHAPTER VI.

Aspect, elevation—Hill, plain, and valley—Distance from sea—Influence of surrounding objects—Winds, rainfall, humidity—Soil and subsoil, and its drainage—Pollutions of soil—Sanitary precautions as to healthiness of site—Ground air and ground water and their pollution.

THE aspect of a building is the point of the compass which the principal front faces. It should not face one of the cardinal points, but is better if midway between, say south-east, so that the sun will reach all faces at some part of the day. Fig. 15 shows a sketch plan of a small country cottage with a suitable aspect, the living room facing south-west, the kitchen at the northern corner, and the bedrooms getting early morning sun. If the position is taken by a compass, allowance must be made for the "magnetic variation." The magnetic north is at present about 14 degrees west of true north, and is reducing at the rate of about seven minutes per annum. Prospect differs entirely from aspect; the former may be described as the view seen from the house, and when there is any choice a good prospect is very desirable.

When a building site in the open country is at some elevation above the general level the air will be fresher, and the wind will tend to remove all deleterious smells and gases, but it may be too exposed for some people and difficulties of transport may render the high position objectionable. The fact is that almost any position may be made healthy, and there are so many points that affect one's opinion of a site that perhaps it is fortunate that not many of us have much choice. An ideal position would be on the southern or south-eastern slope of a gravel hill. A valley might be marshy or subject to flooding near the bottom, but on the sides many desirable sites may be found. Generally, in all positions there is a thickness of about 12 ins. of vegetable earth on top, which is removed before

building begins, and next to it is the subsoil which may be gravel, clay, chalk, or with less covering, hard rock. A peat subsoil is bad but sometimes unavoidable. The main thing is that there should be no water in the subsoil within 5 ft. of the surface, otherwise land drainage must be resorted to. Gravel is very permeable and allows rain to soak in quickly, but there is usually a bed of clay below the gravel which stops the water from going any further; the level therefore rises until the water finds an outlet more or less distant. In the meantime the water level in rising displaces the stagnant air that has been lying in the gravel, and this ground air may or may not be impure;

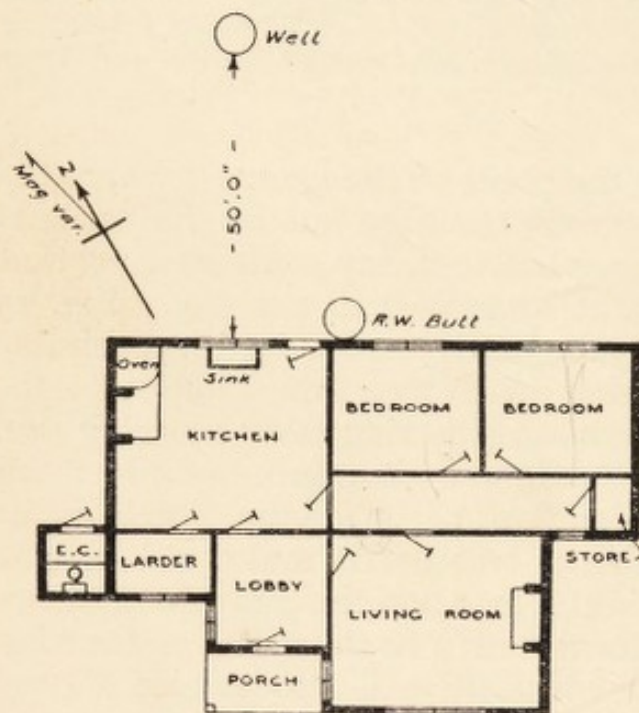

FIG. 15.—Cottage showing suitable aspect with regard to north point.

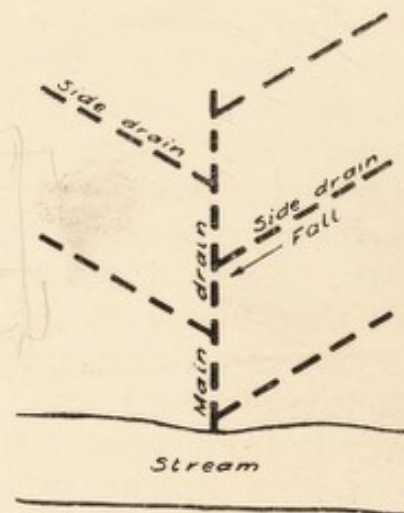

FIG. 16.—Mode or land drainage.

if the former, it must be shut out by a layer of concrete over the whole site of the dwelling.

When a detached house is built on the side of a hill the front will usually face the valley, and to ensure a dry site it is very useful to cut a trench along the back and lay agricultural drain pipes to carry the water that may flow or soak down the hill, clear of the house. A generally damp site may be drained by agricultural pipes if an outfall can be obtained at a lower level. These pipes are of plain red earthenware without sockets, 2 to 4 ins. diameter, laid 3 to 6 ft. deep, and about four times their depth apart, as in Fig. 16. The outlet should be

to a brook if possible, but if it is necessary to drain into a sewer the pipes should be cut off from the sewer by an intercepting trap. The pipes are simply butted against each other end to end, or left with a clearance of not more than  $\frac{1}{2}$  in. They are then covered with brushwood or gravel or rubble chalk or broken brick, to keep back the earth which would otherwise be carried into the pipes with the moisture and ultimately choke them.

Care should be taken to keep the soil in the neighbourhood of dwellings free from pollution. Hollow places should be made up with virgin soil or clean builders' rubbish, dustbin refuse ought never to be permitted, except possibly as a foundation for new roads below the hard core; even then it should have been weathered for two or three years or the decay of the organic matter will let the road down. Manure heaps should have a hard bottom and an open roof over them, and should not be allowed to remain long enough to become a nuisance. A well should be on high ground rather than upon low ground to prevent the ingress of pollution from the surface. A cesspool should not be within 50 ft. of a well, even if surface water is believed to be excluded from the well. Slops should not be thrown on the ground in the neighbourhood of the house.

The chief sources of contamination of the subsoil are badly laid drain pipes and leaky joints, improperly made and placed cesspools, slops thrown on the earth at back of the house; refuse used to make up the ground before building, manure pits or refuse heaps. Any pollution of the soil naturally affects the ground water and through it the ground air, and unless the emanations are shut out by impervious concrete the health of the occupiers of the house must suffer.

The neighbourhood of the sea is attractive to many people, the climate is usually milder than further inland and more equable. There is more movement in the air, a breeze generally blowing on shore in the day time and off shore at night. The air is more humid and contains a noticeable quantity of salt and ozone. About the only objectionable feature is that rust and damp are more prevalent in the house, due to the humid atmosphere. Living in a town is not necessarily unhealthy, even surrounded by high buildings, if proper precautions be taken with regard to ventilation and exercise, but in a manufacturing town the air may be impregnated with smoke

and acid fumes to an objectionable extent. Trees closely surrounding a house render it cooler in the daytime by retarding the evaporation of moisture from the ground and keeping the air humid, and warmer at night by arresting the radiation of heat from the ground, but the house is more likely to be damp and the occupants languid. It is better that no tree should be nearer a building than its full-grown height, say 50 ft. ; this avoids the above-named objections and prevents the risk of damage to the walls and drains by the growth of the roots. It should be remembered that everything that obscures or shuts off the sun from the house and its occupiers takes away a material portion of health and vigour.

We have already referred to winds, rainfall, and humidity generally. It may be noted, however, that in England the north wind is cold and frequently brings snow ; the east wind is generally dry, but in winter may be very cold and what is called "cutting," which arises chiefly from its dryness ; the south-west wind, blowing from the Gulf of Mexico, comes laden with moisture and brings much rain, although the temperature is generally raised. Upon a sudden rise of temperature moisture will generally be found deposited inside the house upon varnished or polished surfaces, such as handrails, painted walls, or those covered with varnished paper, also concrete walls unless plastered. This is because the dew-point is reached and the moisture that is deposited upon colder surfaces will be visible unless they are porous and absorb it.

#### EXAMINATION QUESTIONS RELATING TO CHAPTER VI.

1.—What are the advantages of the different aspects of a window, respectively north, south, east, and west ?

2.—What points of the compass are best for a house to face, and why ? What is the difference between magnetic north and true north ? State approximately at what points the sun rises and sets in January, March, and June.

3.—Sketch the plan of a detached house, showing the best aspect for it. Indicate the positions of sitting-rooms, bedrooms, kitchen, larder, etc., and give reasons.

4.—Name the most suitable aspects for the breakfast-room, dining-room, drawing-room, kitchen, and larder respectively, giving your reasons.

5.—Explain how the healthiness of a dwelling is affected by (a) aspect; (b) position in relation to the sea level; (c) surrounding objects.

6.—What is meant by “ground air” and “ground water”? What circumstances affect the movements of each, and how may they get polluted?

7.—How is a site affected by its distance from the sea? What trees or bushes are suitable for planting near the sea?

8.—Name some of the various objections to the close proximity of trees to a house. What rule would you lay down for the minimum distance from the trees to the house?

9.—Ground air is the air in the ground or soil between the level of the subsoil water and the surface. Is it present in all soils, and how does it vary according to the character of soil, climate, rainfall, and season?

10.—What is meant by “ground air”? Why is it impure, and what precautions are taken to prevent it entering dwellings?

11.—The growth of towns frequently carries the extension of streets and houses over disused brickfields, perhaps levelled up and covered with vegetation. State what conditions of disadvantage to buildings you would look for, and how you would overcome them?

12.—Explain how the sanitary condition of a house may be affected by ground air, and how ground air is affected by ground water, and how both may become polluted. Assume a case where such pollution exists—what measures would you take to prevent any injurious influence in a house?

13.—A few years ago it was customary in the suburbs of London to fill up a low-lying site with dustbin refuse, and then to build upon it. What were the hygienic objections, could they be overcome, and what is the present law upon the subject?

14.—At what depth below the surface would you commence the foundations for a house upon clay and gravel subsoils respectively?

15.—What are the causes of fluctuations in level of subsoil water? What is the effect of such fluctuations upon the healthiness of the locality in which they occur?

16.—Enumerate various subsoils of sites for buildings under the following heads: (a) porous; (b) impervious. Underline the two which you consider most desirable.

17.—Give examples of porous and of impermeable soils. How are they affected by subsoil water, and which is the healthier to build upon?

18.—What do you consider an unhealthy ground water level for a building site, and why is a fluctuating ground water level more

unhealthy than a permanently high one? Explain under what conditions a sand and gravel site may be undesirable and unhealthy.

19.—If houses are to be erected upon "made ground," specify the precautions you would order to be taken.

20.—Which do you consider the more dangerous, a permanently high level of ground water or a fluctuating ground water with lower average level? Give reasons for your answer.

21.—What are the conditions of site that require a layer of concrete all over? What should be the thickness and composition of the concrete?

22.—What are the risks to health and comfort involved by residence upon (a) clay; (b) gravel; and (c) made ground respectively, and how may these risks, in great measure, be obviated?

23.—Explain, in detail, the method of draining the clay subsoil of a site 150 ft. square, having a public road upon one side. Give a sketch plan of the drains to scale.

24.—Compare the advantages and disadvantages of a site for a private dwelling (a) on a hillside on the chalk; (b) in a valley surrounded by pine woods; (c) in the fen district.

25.—How would you determine the nature of a subsoil and the level of the subsoil water?

26.—A house is built near a stream and the ground falls towards the stream. On which side of the house would you place (a) a well; (b) a cesspool; and how far away from it in each case?

27.—Complaint is made that a dwelling built of reinforced concrete is cold and damp and that the walls are often wet inside. Explain the cause and describe the remedy.

28.—Under what circumstances do the walls of a room show condensed vapour? Why is a down-draught sometimes felt when sitting against a wall or a large window, although there is no opening from which it may come?

29.—You are asked to advise on a site for a sanatorium for tuberculosis. What conditions would you require? Give reasons.

SECTION III.  
AIR, LIGHTING AND WARMING.

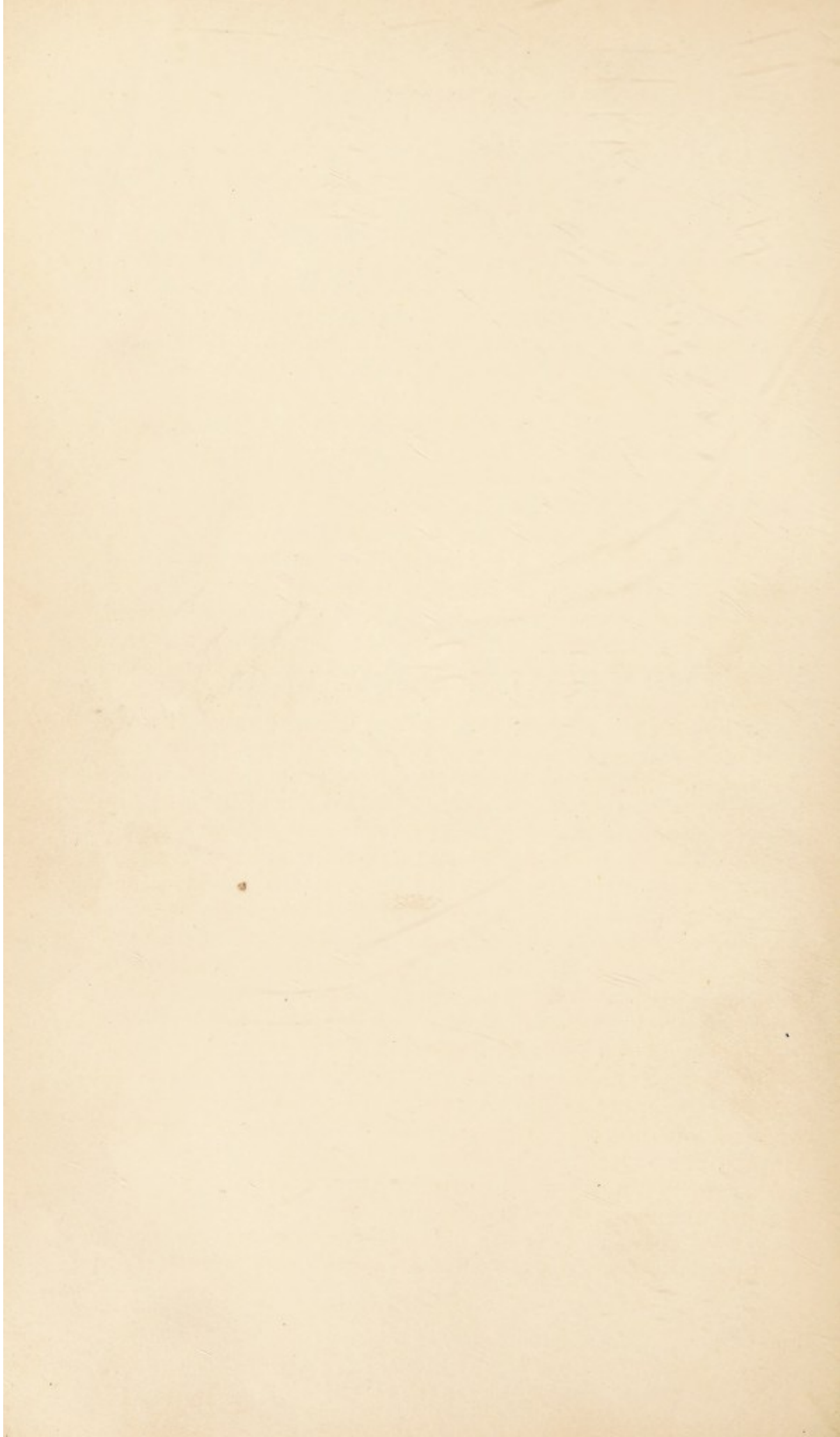

## CHAPTER VII.

Air movements—Sources of pollution—Principles of ventilation—Air space and quantity required—Methods of, and appliances for, ventilation—Ventilation of public buildings, hospitals, schools, factories, dwelling-houses, etc.

THERE are two important compounds of carbon and oxygen. First, carbon monoxide, CO, generally called carbonic oxide, and composed of equal volumes of carbon and oxygen. It is a transparent gas, highly poisonous, burning with a blue flame, as seen on top of a coke fire. Second, carbon dioxide, CO<sub>2</sub>, generally called carbonic acid, and composed of two volumes of oxygen to one of carbon. It is a transparent, heavy, inert gas, not directly poisonous but acts prejudicially by excluding oxygen. Trees and plants absorb carbonic acid and give off oxygen. Animals absorb oxygen and give off carbonic acid.

The open air contains generally about .04 per cent. of carbon dioxide (CO<sub>2</sub>), but in a room this may reach .06 per cent. without discomfort. Beyond that amount a languid feeling is produced and a sense of stuffiness. This is, however, not due to the carbon dioxide, but to the products of combustion, respiration, perspiration, etc., with which it is accompanied, often called the "homo" smell. For factories (Departmental Report, 1902) the carbon dioxide may reach 0.12 per cent. during the day and 0.2 per cent with gas burning. A mineral water factory is an exceptional case; the carbon dioxide in the air is no measure of its unhealthiness as it is not accompanied by the other deleterious products of the body, and may reach 3 per cent. without prejudice to health or comfort. It is not so much the impurity of the air that affects the individuals in a crowded room as it is the high temperature and humidity, or to put it another way—in ill-ventilated rooms the heat and

moisture are more serious defects than the vitiation of the air. With a maximum of 65° F. and a humidity of 70 per cent. of saturation, no discomfort should be felt.

Perflation, or the flushing out of a room at intervals with vigorous drafts of fresh cool air, is very important from a health point of view; nothing is more enervating than monotonous warmth. The carbon dioxide due to respiration is thus estimated: the respirations average 20 per minute of 30 cub. ins. each, or 20 cub. ft. per hour, of which 0.6 cub. ft. is carbon dioxide. In order to keep the air of the room down to .06 per cent. of carbon dioxide, it will therefore be necessary to introduce per hour 3000 cub. ft. of fresh air containing .04 per cent.

carbon dioxide, thus: 
$$\frac{0.6 \text{ respired}}{\frac{.06}{100}} - \frac{.04}{100} = 3000 \text{ cub. ft. fresh air.}$$

Assuming the room to have a volume of 1000 cub. ft., this would mean that the air must be renewed three times every hour. If more persons than one are using the same room it should be of proportionately larger size and the air renewed at the same rate three times per hour. These are ideal conditions some of the advantages of which must be relinquished in practice.

In factories the allowance for cubic space per individual is 250 cub. ft. for daywork and 400 cub. ft. for overtime when artificial lighting must be in use. Technically, a factory is a place where work is done by power machinery, but printing works and tobacco factories are classed as factories, even if they have hand machinery only; a workshop is a place where work is done by hand machinery only; a workplace is where work is done by hand only. In common lodging houses 300 cub. ft. net for adults, 150 cub. ft. for children under ten years of age are required, but the space for adults must be increased to 450 cub. ft. if the same room is used for living and sleeping. In barracks 600 cub. ft. are allowed, and in prisons 800 cub. ft. Houses let in lodgings 400 cub. ft. In canal boats 7 ft. 6 in. wide, after cabin 180 cub. ft. for two persons, fore cabin 80 cub. ft. for one person, or 60 cub. ft. for adults and 40 for each child under twelve; 3 gallons of water must be carried for each person and bilge must be pumped out every twenty-four hours. Also double bulkhead with 6-in. space if offensive cargo. For cow-sheds, 800 cub. ft. if stall fed, 600 if field fed, 4 ft. feeding

passage, 2 ft. feeding trough, 8 ft. standing space, 2 ft. manure trench, 5 ft. milking passage = 21 ft. total. Single stall 4 ft. wide, double stall, 7 ft. wide.

An isolation hospital requires the maximum of 2000 cub. ft. per patient, with 12 lineal ft. of wall space and 50 sq. ft. of floor space. In old schools 100 cub. ft. and 8 sq. ft. of floor area, in new schools 120 cub. ft. and 10 sq. ft. of floor area. The air space is in all cases limited to a measurement of 12 ft. high, however much the ceiling or roof may exceed this. In schools, light is almost as important as ventilation, the window area for class-rooms should be one-fifth of the floor area, and for other rooms one-eighth. The light should be on the left of the scholars. The Staffordshire type of school, having no central hall, allows cross ventilation of all class-rooms.

In a garden city there should not be more than five houses, or twenty-five inhabitants to the acre, but in town suburbs it may rise to twenty houses, or one hundred persons per acre. In the National Housing Scheme twelve houses are allowed per acre. It is incorrect to say that air movements are caused by the wind, the wind is air in movement, and the movement is due to changes in density and temperature, the position and amount of cloud shutting off the heat of the sun from some parts while leaving it acting elsewhere, and other causes.

The velocity of air entering a room to ventilate it should not exceed 2 to 3 ft. per second or a draught will probably be felt, depending upon the relative temperature of the present and the incoming air. The inlets should be larger than the outlets, say inlets 1 sq. in. for each 50 cub. ft. of space; outlets, 1 sq. in. for each 60 cub. ft. of space. Some authorities say that the outlets should be the larger because the air is heated and expanded in the room, but there is no limiting velocity in consequence of draught as in the case of inlets. An ordinary fire-grate in use requires about 500 cub. ft. of air per minute, and the velocity of the heated air and products of combustion up the chimney is from 5 to 10 ft. per second. This accounts for the draught felt from the door and windows in a closed room. De Chaumont's formula for the velocity of heated air in a chimney or ventilation trunk is

$$v \text{ ft. sec.} = \sqrt{.13(H - h)(T - t)}$$

and Montgolfier's is

$$v \text{ ft. sec.} = 8c\sqrt{\frac{(T - t)(H - h)}{491}}$$

Where  $H$ ,  $h$  = the heights in feet of outlet and inlet above the ground,  $T$ ,  $t$  = the temperature in  $F.^{\circ}$  internally and externally,  $c$  = coefficient of friction, say  $\cdot 75$ . Taking  $H = 30$ ,  $h = 10$ ,  $T = 200$ ,  $t = 60$ , then by the two formulæ,  $v = 19$  and  $14.4$  ft. sec.

The simplest way to ventilate a room is to open the window. If it consists of double hung sashes, the top sash may be lowered say 3 ins. and left open unless the wind happens to be in that direction, when the foul air would be driven back by incoming fresh air. A method recommended is to lift the bottom sash 3 ins. and to close the opening with a board; this is known as the Hincks-Bird method. The fresh air entering at the meeting rails is less likely to cause a draught, but it is not so effective as lowering the top sash which gives the opening at the meeting rails for fresh air and the opening at top rail for the emission of foul air.

Another method of admitting fresh air is by a Sheringham ventilator fixed in the outer wall with a movable flap on the inside which deflects the current upwards. The flap has a cord and balance weight so that it may be set at any angle. Tobin tubes to admit fresh air are more suitable for public rooms; these are vertical rectangular tubes of wood or metal, usually rising from the floor level to a height of 6 or 7 ft., the bottom connected through the wall with an inlet grating from the open air. The flow is controlled by a regulating valve, and sometimes an air filter of gauze is inserted in the tube. The top should slope forward so that nothing can be placed on it that might render it ineffective, and a curved shield should be fixed between the tube and the wall to prevent discoloration from incoming dust. Arnot ventilators are brass perforated frames let into the upper part of a chimney breast leading into a chimney flue or a special ventilating flue built up with the chimney flues. Inside is a silk flap opening inwards. The dirt surrounding the ventilator is wrongly supposed to be due to escaping smoke, it is really the dust deposited by the current of air towards the ventilator; the air is deflected to the openings but the particles of dust having more weight continue in straight lines and strike the wall surface, where they remain. Public halls may be ventilated by Tobin tubes and Sheringham valves for inlets, and exhaust cowls or louvred ventilators in the roof for outlets, but in heating and ventilating by the plenum system (described further on) the inlets should be near the top

and the outlets near the bottom or on the opposite side. Complaint has often been made by persons sitting in a public hall or room near a window which is unusually large and high, that there is a constant draught from it, although careful inspection fails to discover any crevice by which it may have entered. It will be found that this apparent draught occurs when the outside air is colder than the inside, so that the inside air next the window is chilled and falls by its own weight. Advantage has been taken of this property in a suggestion that with a plenum system the outlet for foul air being placed just below the window sill it would be removed without circulating again through the room, the inlets for fresh warmed air to be behind the skirting, or not more than 7 or 8 ft. above floor level on the opposite side of the room, or in the piers between the windows if they are on both sides of the room.

#### EXAMINATION QUESTIONS RELATING TO CHAPTER VII.

1.—What is the composition of pure air, and how much does a healthy person require per hour on an average? What is the composition of expired air?

2.—Name some of the causes of  $\text{CO}_2$  in the atmosphere, and explain why it does not go on indefinitely increasing.

3.—How does the air of a room become vitiated when occupied by human beings, and show how you arrive at the conclusion that if a person occupies a room of 1000 cub. ft. capacity, the air should be changed three times each hour, if a satisfactory degree of purity is to be maintained?

4.—A room in which there are four adults has a capacity of 2200 cub. ft. If the outside air contains 0.45 cub. ft. of carbon dioxide per 1000 cub. ft., what quantity of fresh air must be supplied to the room per hour in order that the standard of permissible impurity may not be exceeded?

5.—A room 9 ft. high, 20 ft. long, and 10 ft. broad contains six persons. The ventilating inlets, four in number, have a total area of 1 sq. ft. With what velocity per minute will the air have to enter through the inlets to supply 3000 cub. ft. per head per hour? Would the conditions given be satisfactory for a dormitory or sleeping room?

6.—A wooden trunk, 18 in. by 12 in. inside, is used for the outlet of foul air from a concert room. Its height is 12 ft., the temperature

of the foul air  $80^{\circ}$  F., and of the external air  $55^{\circ}$  F., what will be the discharge in cubic feet per hour?

7.—A ventilating shaft is 50 ft. high and 18 ins. square, how much air would ascend through it per minute when the temperature is  $20^{\circ}$  F. greater than that of the atmosphere?

8.—What constitutes a draught? What are the chief constituents of atmospheric air, and in what proportions do they exist?

9.—Why should it be necessary to consider floor space as well as cubic capacity in dealing with the ventilation of a room? What is meant by over-crowding in a dwelling?

10.—What quantity of moisture should wholesome air contain in proportion to saturation? Under what circumstances does the air of a room become too dry or too moist, and how may the excess in either be avoided?

11.—Describe the effects which (*a*) respiration, and (*b*) combustion have on the composition of the air.

12.—Compare the air of an occupied room with outdoor air in respect particularly of composition, and name the chief reasons for any differences commonly recognised.

13.—What is the effect upon the air of a room by the burning of a gas jet?

14.—How many cubic feet of air space are necessary per person in workshops, common lodging houses, private bedrooms? What is the maximum velocity through fresh-air inlets? Name and sketch the appliances used in ventilation.

15.—What is a "factory" under the Factory and Workshops Acts? A room 16 ft. by 14 ft. by 10 ft. in height is occupied in the daytime by nine workpeople. Is it over-crowded, and, if so, to what extent?

16.—Enumerate the impurities likely to be found in the air of a sitting-room and the source of each. If these are allowed to accumulate, what would be the probable effect upon the occupants? State in what way each may be detected, and explain how they can be removed.

17.—Discuss the question of low versus high ceilings in respect to ventilation. In a sitting-room 12 ft. 6 ins. high what should be the height of the window sill and window head?

18.—Give a specification for ventilating a sleeping-room without a fire-place, to be occupied by four adults. The room is 30 ft. by 10 ft. and 10 ft. high; one 30 ft. wall and one 10 ft. wall being external, the only window being in the 30 ft. wall. State the size, position, and description of the openings which you would recommend.

19.—What is the composition of pure air, how does it become polluted, and by what natural causes does it become purified again?

20.—What are the component parts of (a) pure atmospheric air; (b) pure water? What are the usual sources of contamination of air and water in dwelling-houses? What is the natural law as to the diffusion of gases?

21.—Describe three methods of introducing fresh air into the rooms of a terrace house; and explain by sketches three methods of removing the vitiated air from the same rooms. State which you consider the best methods.

22.—State what provisions should be made in a school dormitory as to cubic space and change of air to ensure good health. What limit as to height should be taken in the calculation? How much air is required per hour?

23.—What is meant by "natural" ventilation? Describe the essential features of the "plenum" and "vacuum" systems.

24.—What should be the least dimensions of a sleeping-room to accommodate four adults in a private house? To what height would you restrict the measurement, and why? What means of ventilation should be provided, and what would be the size and nature of the ventilating openings?

25.—In a room full of people what are the differences between the air near the floor and that near the ceiling? What influence, if any, have these differences, or any of them, upon ventilation?

26.—Describe the forces that may be acting in the natural ventilation of a schoolroom.

27.—What is the approximate quantity of fresh air drawn into a room per minute where an ordinary open fire is burning? Why does heated air rise in the chimney?

## CHAPTER VIII.

Over-crowding on space and in buildings—Air space surrounding buildings—Angle of daylight illumination—Methods of artificial lighting, advantages and disadvantages—Size and position of windows.

OVER-CROWDING on space occurs when the population per acre exceeds, say, 100 persons. In buildings, over-crowding occurs when the occupiers have less than, say, 1000 cub. ft. of air space each, although from the previous notes it will be seen that certain smaller allowances are made when the building is under supervision. In slum property often two families or more are found to occupy a single room; there is even one case reported where a teacher in a "ragged school," before Board Schools were started, offered a picture to one of his boys to take home and hang on the wall. The rejoinder was, "Please, teacher, we ain't got no wall, we only got the middle o' the room," and it appeared that the four corners of the room were occupied by four separate families. The minimum air space surrounding buildings is fixed by the London Building Acts, 1894. An open space of not less than 150 sq. ft. must be provided at the rear, extending the whole width of the building and not less than 10 ft. in depth from the building, free from erections above pavement level except W.C.'s., ash receptacles, and enclosing walls. The building must not be higher than a line of  $63\frac{1}{2}$  degrees from the back boundary. In Liverpool new houses must not be carried higher than a line of 45 degrees from the ground line of the opposite buildings or the centre of the back boundary. In some towns back-to-back houses are in existence, with the object of saving space and still "giving every Englishman his own castle." This method of building is very objectionable for many reasons, but perhaps the chief objection is that no through current of air can be obtained to ventilate the rooms, and a lowering of vitality results. The

sun is the great health-giver and purifier, and as much sunlight as possible should be admitted to every house. The "angle of illumination" is given by the directions in which the light can enter a room. An open prospect in front allows an angle of illumination of 90 degrees from the level of the window sill. With a building in front more or less of this is cut off by the obstruction. Several methods have been proposed for measuring the value of the light coming to a window; the following is fairly simple.

The relative position of a window and obstructing building can be shown upon a plan and the angles measured horizontally (Fig. 17) and vertically (Fig. 18) from the centre of the window sill. These angles may vary from 0 to 90 degrees, right and

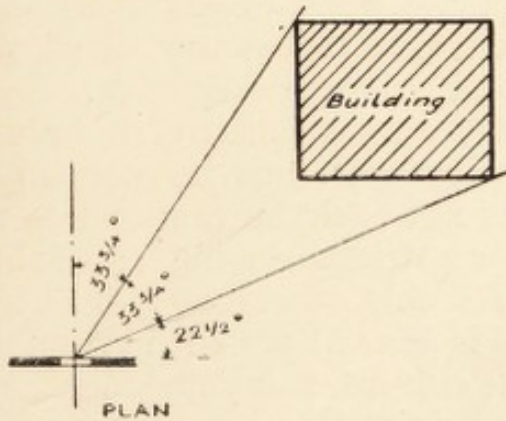

FIG. 17.—Block plan of building showing horizontal angle of light obstructed from window.

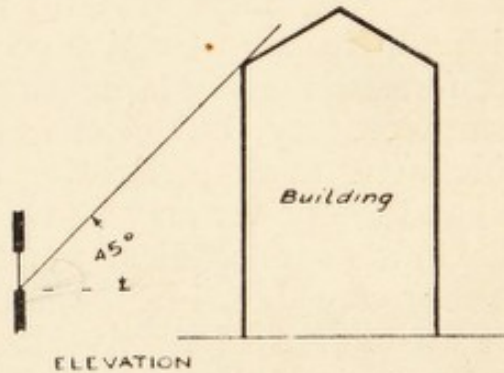

FIG. 18.—Elevation of building showing vertical angle of obstruction.

left, and from the sill upwards. The following table gives the approximate value of each space of  $22\frac{1}{2}$  degrees. Suppose the possible value of the whole light unobstructed be 100, then these rectangles will be worth the amount allotted to each in the table:—

.2	.6	.65	.68	.68	.65	.6	.2
.98	2.9	3.2	3.3	3.3	3.2	2.9	.98
1.6	4.7	5.1	5.4	5.4	5.1	4.7	1.6
2.0	5.8	6.3	6.7	6.7	6.3	5.8	2.0

Suppose the angles to be as shown in Fig. 13, then the value of the portion obstructed will be given by the figures taken from the table thus: For  $22\frac{1}{2}^\circ$  to  $45^\circ$  horizontally and  $45^\circ$  vertically  $4.7 + 5.8 = 10.5$ . For  $45^\circ$  to  $55\frac{1}{4}^\circ$  horizontally and  $45^\circ$  vertically,  $\frac{1}{2}(5.1 + 6.3) = 5.7$ . Then  $10.5 + 5.7 = 16.2$  per cent. of the light is obstructed.

When the rays of light from the sun are transmitted through a triangular prism, they are separated into the colours of the rainbow, red, orange, yellow, green, blue, indigo, violet. The heat rays come from the red end, the light rays from the middle, and the chemical rays from the violet end. There are infra-red rays which give heat but cannot be seen, and ultra-violet rays which have special chemical activity, but are beyond our range of vision.

Artificial lighting in the order of the progress of civilization may be summarized as torches, candles, lamps, gas, electricity. The first we may reserve for London fogs alone, the second was the common illumination of the working classes for the first half of the nineteenth century, ranging from the farthing rushlight to the respectable middle-class composite candle. Oil lamps are still much used in country districts; with a little care they give good and economical lighting. Coal gas formed the staple lighting of the second half of the nineteenth century, but electric lighting now runs it very close. This latter mode of lighting does not foul the atmosphere at all, and the power may be used for heating, cooking, and doing all kinds of mechanical work. Its only objection is its cost. Greater care should be taken than is done at present in running the various leads for conveying the current, many fine mansions having been destroyed by the fusing of a connection or from stray currents induced by damp surroundings. For country houses the light may be obtained from storage batteries charged during the day by a dynamo driven by a small oil engine, or, if water-power exists in the neighbourhood, by a small turbine. The pressure or intensity of an electric current is called its voltage and is measured in volts. The quantity of a current is called its amperage, and is measured in ampères, often called amps.

Coal gas is cheap and convenient but vitiates the atmosphere to a considerable extent. The percentage composition of coal gas is approximately: hydrogen, 50; hydrocarbons, 40; carbon monoxide, 5; nitrogen, 4; oxygen, etc., 1. On combustion it yields  $\frac{1}{4}$  its volume of carbon dioxide and  $1\frac{3}{10}$  its volume of watery vapour, besides small quantities of sulphur dioxide. It requires  $5\frac{1}{2}$  times its volume of air for complete combustion. When mixed with air it will explode when there are from 4 to 14 volumes of air to 1 of gas: about 8 to 1 makes the strongest explosion. A single gas jet is considered to cause as much impurity in the air as three men, an oil lamp

one man, and a candle is negligible except in a very small room. An ordinary gas jet consumes 3 cub. ft. of coal gas per hour.

Acetylene gas is made by adding water to calcium carbide, thus—



and when burnt in the air



thus producing a large quantity of carbon dioxide. The light is small but very brilliant. The gas is generated so readily that it is frequently used for lighting bicycles and motor-cars.

Petrolised-air gas is used in many country places; it consists of about 98½ per cent. of atmospheric air which takes up about 1½ per cent. of petrol vapour. Passing through a wire gauze burner it lights with a very pale flame but gives an intense white light when used with an incandescent mantle. The amount of petrol used is 1 gallon to 1600 or 2000 cub. ft. of gas, and 1 cub. ft. of this gas represents 10 candle-power-hours. A "candle-power-hour" is equivalent to the light of a standard candle for one hour. The standard candle is a sperm candle, six to the pound, 7⁄8 in. diameter, and burning at the rate of 120 grains of spermaceti per hour. A "foot-candle" is the intensity of illumination produced upon any surface 1 ft. distance from a light source, giving one candle in such a manner that the light rays strike the surface at right angles. Illumination follows the law of inverse squares, thus—

$$\text{Foot-candles} = \frac{\text{candle-power}}{\text{distance squared}}$$

The illumination of different places should vary according to the work carried on. The amount in foot-candles may be taken approximately as follows: For passages, warehouses, and places requiring very moderate illumination, ½ to 1. For churches, schools, offices, living-rooms, etc., 2 to 4. For drawing offices, needlework, and fine operations, 4 to 6.

Window area is generally proportional to floor area, but many authorities introduce the cubic space of the room into the calculation. For example, in school class-rooms the window area is one-fifth of the floor area, in other rooms one-eighth, and

in private houses often only one-tenth. Other rules are window area =  $\sqrt{\text{contents of room}}$  (Robert Morris); breadth of window =  $\frac{1}{8}$  (breadth + height) of room, height of window = 2 to  $2\frac{1}{2}$  times breadth (Sir W. Chambers); 1 ft. super of window space to every 100 or 125 cub. ft. of contents of room in dwelling-house, and 1 ft. super to 50 or 55 cub. ft. contents in hospitals (Sir Douglas Galton); 1 ft. super to every 100 cub. ft. contents (Joseph Gwilt); width of window = side of square whose diagonal is the height (J. S. Adams). The window sill should average 30 ins. above the floor and the top of the window should be as high as possible. A room 8 ft. 6 ins. high with the top of window 6 ins. from the ceiling is better than a room 10 ft. high with the top of window 2 ft. from ceiling.

Lights are compared by various forms of photometer, the simplest of which is Bunsen's, known as a grease-spot screen. If a standard candle be placed at one end of a table and the light to be measured is placed at the other end, a frame carrying a piece of paper with a grease spot in the centre is moved away from the standard candle and towards the other light until the spot disappears because of equal illumination on each side. Let  $d$  = distance in inches from candle to screen, and  $D$  the distance from screen to the light being measured, then

$$\left(\frac{D}{d}\right) = \text{the candle-power of the light.}$$

#### EXAMINATION QUESTIONS RELATING TO CHAPTER VIII.

1.—Explain the dangers of "over-crowding on space" and "in dwellings," and state the desirable limits.

2.—The National Housing Scheme provided twelve houses per acre, how many square feet would thus be allotted to each house, deducting 20 per cent. for roads and footpaths? What size plots would this give?

3.—What regulations do you know of with respect to the space about buildings to secure a free circulation of air?

4.—State the general principles to be borne in mind for securing a sufficiency of fresh air in towns, as regards (a) width of street; (b) length of streets without cross streets; (c) minimum area of open space at rear of buildings, and minimum distance between buildings at the rear; (d) provision of open spaces for recreation. X

5.—Why is sunlight in a house desirable? Explain what is meant

by the solar spectrum, and state which are known as heat rays and which as chemical rays.

6.—Compare the efficiency of square and octagonal bay windows and of flat front windows for lighting and ventilating living-rooms. Also, compare the ventilating efficiency of casement windows, with double-hung sashes.

7.—What are the principal causes of deficient lighting in dwelling-houses? State in what manner they can be obviated.

8.—Describe three different forms of artificial lighting; state the advantages and disadvantages of each, and the purpose for which they are best suited.

9.—What are the constituents of coal gas? What changes take place in the air of any space in which coal gas is burnt? What is meant by (a) the illuminating power, and (b) the calorific value of coal gas?

10.—How is the illuminating power of a given light measured? Illustrate your answer by sketches.

11.—Compare, from a health point of view, the advantages and disadvantages of the following illuminants: (a) oil; (b) gas; (c) electricity; (d) acetylene; (e) paraffin. What is CO?

12.—Specify an installation of (a) electric lighting; (b) gas lighting, for an elementary school. Compare their sanitary merits.

13.—In artificial lighting what is meant by candle-power, and what candle-power is desirable as measured by floor area for workshops and for public assembly rooms?

14.—Compare the relative merits of acetylene gas, petrol gas, and electric light for country house illumination.

15.—Describe the plant required for lighting a house by acetylene gas, stating any precautions that are necessary.

16.—If a grease-spot screen be placed at 1 ft. from a standard candle, what will be the candle-power of a gas light that cancels the grease spot at a distance of 3 ft.?

17.—State briefly the merits and defects of lighting by gas, oil, and electricity, and describe the construction of (a) an incandescent gas burner; (b) an electric arc lamp.

18.—A standard candle is placed at one end of a photometer scale 4 ft. long. A gas jet of 9 candle-power is placed at the other end, where will the grease-spot screen have to be placed for the spot to disappear?

19.—Describe the principle of an electric light switch for a room in a private house. What is the difference between voltage and amperage?

20.—What do you consider should be the window surface for a room containing 3000 cub. ft.? Explain how ventilation can be provided for (1) in a room where the fresh air has to be warmed; (2) in a large school dormitory?

21.—What is the composition of ordinary gas as used in lighting rooms? What is the nature, and what are the amounts of the impurities which it yields to the atmosphere during combustion. Apply these facts to the requirements of ventilating dwelling rooms lighted by coal gas, and state what provisions should be made for dealing with them.

## CHAPTER IX.

Warming buildings by open fire, stove, hot water, steam, hot air.

THE best way to warm a room is by open fires, whether coal or gas. The objections to gas fires when they were first adopted were partly founded on misconceptions, and partly due to improper fixing, so that products of combustion escaped into the room. Enough is now known about them to prove their economic value without any drawback on the score of hygiene. Medical men had an idea that carbon monoxide oozed through the pores of the metal, now they know better and use gas stoves. With coal fires a large passage-way is left to the chimney and this acts as a vigorous outlet for foul air, but the opening is rather too low down for that purpose, and often results in merely causing a draught from the doors and windows. Gas fires must always be fixed with an outlet into the chimney, and sometimes the only air that can reach the chimney being through the fire, the resulting ventilation is rather sluggish. It is a mistake to suppose that a gas fire dries the air of a room, and that headaches are caused by sitting over gas fires; a gas fire is no different in these respects from a coal fire, except in so far as ventilation may be impeded as mentioned above. The placing of a saucer of water on the hearth in front of a gas stove to moisten the air is another fallacy, as, when tested, it will be found that all the vapour goes direct to the fire and is lost so far as the room is concerned. The early gas fires were built up upon the model of open coal fires; irregular lumps of baked clay mixed with asbestos were laid in the grate, and the gas, after mixing with air, was admitted through Bunsen burners to the "fuel." This was a wasteful method, and is now quite replaced by the grate that shows all front, the mixed gas and air passing up open terra-cotta lattice tubes and being

backed by ribbed fire-clay blocks which become incandescent, gives a bright appearance and radiates the greater part of the heat produced. The fumes from a Bunsen burner, although not visible, are deadly. They consist chiefly of carbon monoxide and carbon dioxide ; it is a pure fallacy to suppose that the carbon in the gas is completely destroyed, as has been asserted publicly by some who should have known better. Flueless gas stoves with ordinary gas jets (not Bunsen), and with what are called condensers, may be used in halls and passages where there is good ventilation, but they are not safe for living-rooms and business offices.

Stoves, or closed fires, standing out in the room are now seldom found. They were formerly common in schools, lecture halls, churches, and hospitals, but their place has now been taken by hot-water pipes and radiators. The Galton stove in a chimney breast and the Manchester stove placed out in the room with access all round were among the best.

Large buildings are sometimes heated and ventilated on the " plenum " system (*plenum*, Latin, full), by which hot air is forced through trunks or air-ways into the various rooms. It has only one advantage—there are no draughts, but it has every possible disadvantage, and is totally opposed to hygienic principles. Even the old Romans knew that the floors and walls should be warmed and the air kept cool. At the New Bailey, Newgate Street, the system is said to have cost £46,000 to install, and was universally condemned by the judges and counsel engaged there. Mr. R. D. Muir (the well-known counsel) said : " Our feet are frozen and our heads are boiled."

The vacuum system of ventilation is not associated with the heating arrangements. It consists usually of exhaust cowls on the roof, with openings from the ceilings, the air being sometimes assisted by electric fans at the ceiling level. The disadvantage of the vacuum system for drawing off the foul air is that it creates a draught from the doors and windows.

Heating by low-pressure hot water is the favourite method, with a radiator temperature of 180° F. as a maximum. What is called the two-pipe system is preferred, and can be used either to provide warmth or hot water, or both. It is a gravity system, that is, the water circulates by reason of the difference in temperature, and, therefore, of density and weight, in the flow pipe and the return pipe. It can be arranged with a hot-water tank for small installations or with a hot-water cylinder

for larger installations. Fig. 19 shows the tank system, which has a single circulation. Fig. 20 shows the cylinder system with short circuit to boiler, and a single flow-pipe to sink, bath, lavatory, etc. Fig. 21 shows the cylinder system, with a double circulation. A stop valve on the return pipe can be shut off at night so that only the primary circulation then takes place and the water in the cylinder will be still warm in the morning. The supply of hot water is generally taken off the flow-pipe, but in particular cases it may be drawn from the return pipe; the former is, of course, the hotter. The pipes

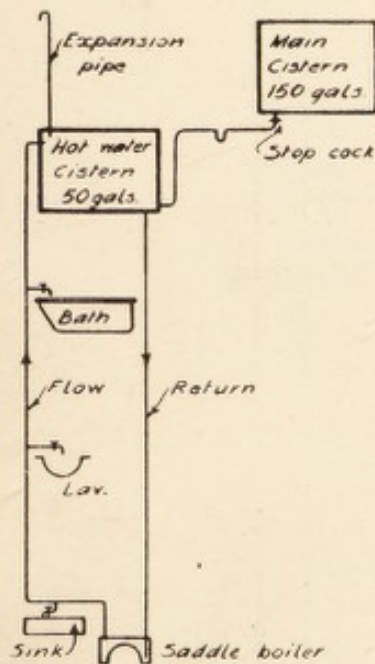

FIG. 19.—Tank system of heating by hot water.

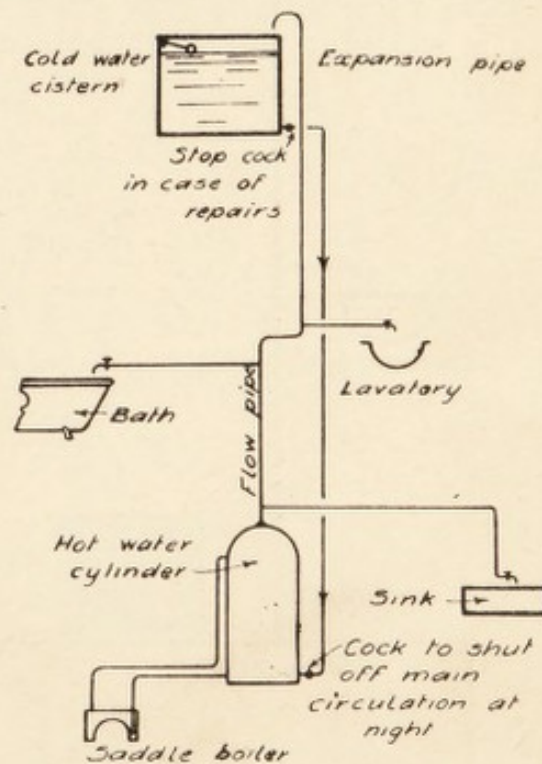

FIG. 20.—Single pipe cylinder system of heating by hot water.

should be laid with a fall to allow air to escape and to be able to drain them when required. Radiators are usually connected to both pipes, but in some instances both the inlet and outlet of the radiator are connected to the same pipe, with the disadvantage that the temperature in the pipe beyond the radiator is reduced. Fig. 22 shows the construction of a radiator. It will be seen that the hot water goes to the top in the first standard and then falls down each section towards the outlet.

For central heating installations the principle of circulation is the same as for hot-water supply, but there is no closed tank

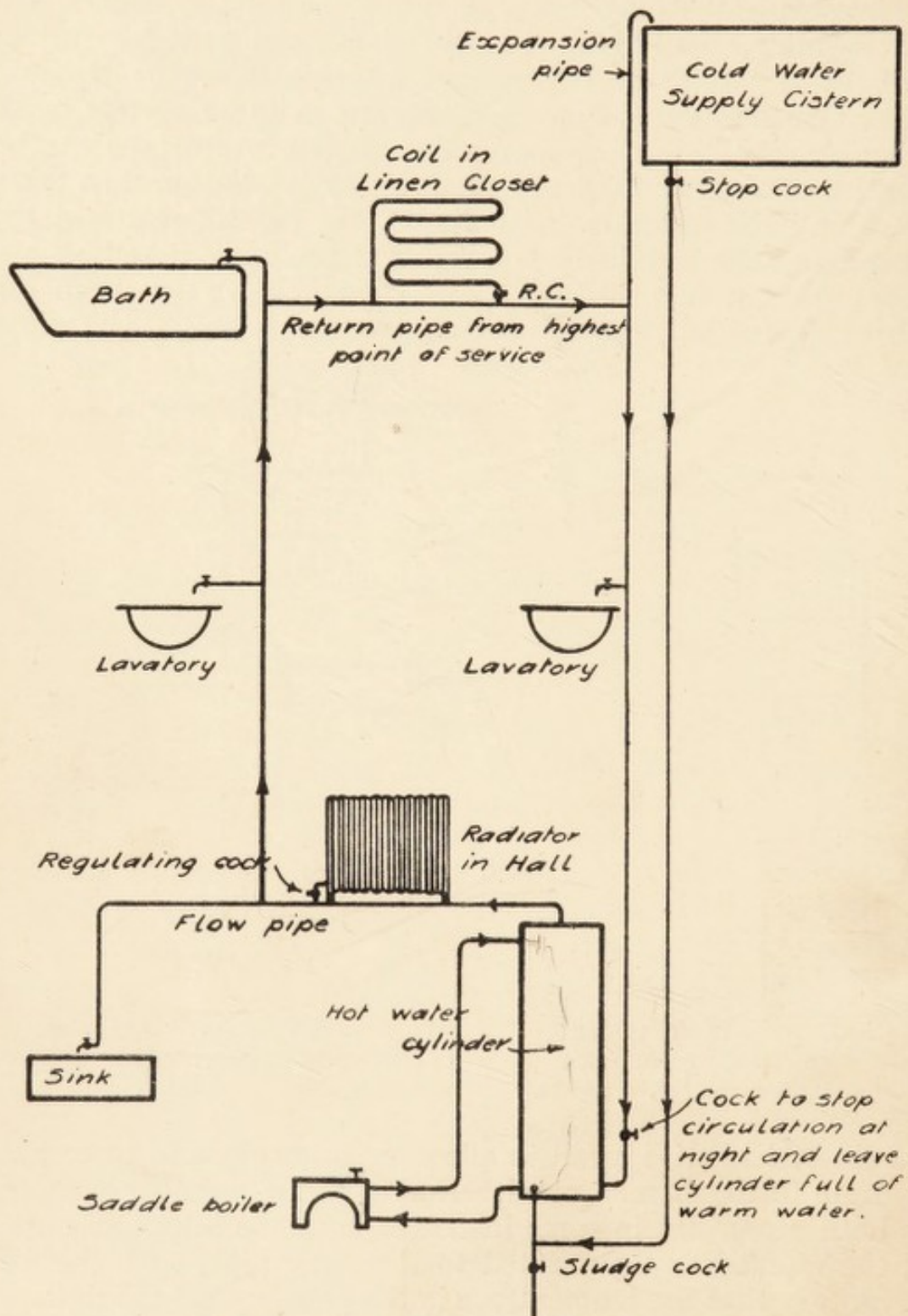

FIG. 21.—Two-pipe cylinder system.

or cylinder. There are two chief systems, one having the main pipes laid on the ground floor with connections carried up to the radiators on higher floors, as in Fig. 23, and the other

called the drop system, with the flow-pipe carried straight up to the top floor and radiator branches taken off the return pipe on its passage back to the boiler, as in Fig. 24.

In large buildings such as hospitals, asylums, etc., with low-pressure hot-water systems, the circulation is sometimes increased by the insertion of a centrifugal pump in the main water circuit, which either pulls the water along the return or pushes it along the flow pipe.

High-pressure hot-water systems are principally used for churches. They are constructed of small diameter wrought-iron pipes filled with water and hermetically sealed so that there is no steam space and no evaporation or waste, unless a leak should occur.

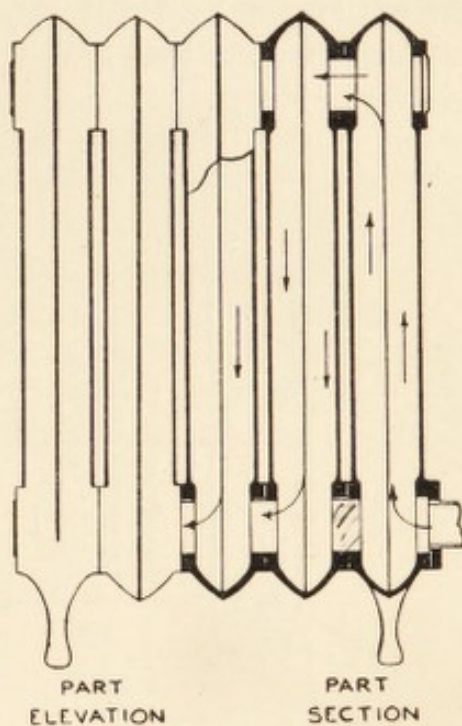

FIG. 22.—Hot-water radiator partly in section.

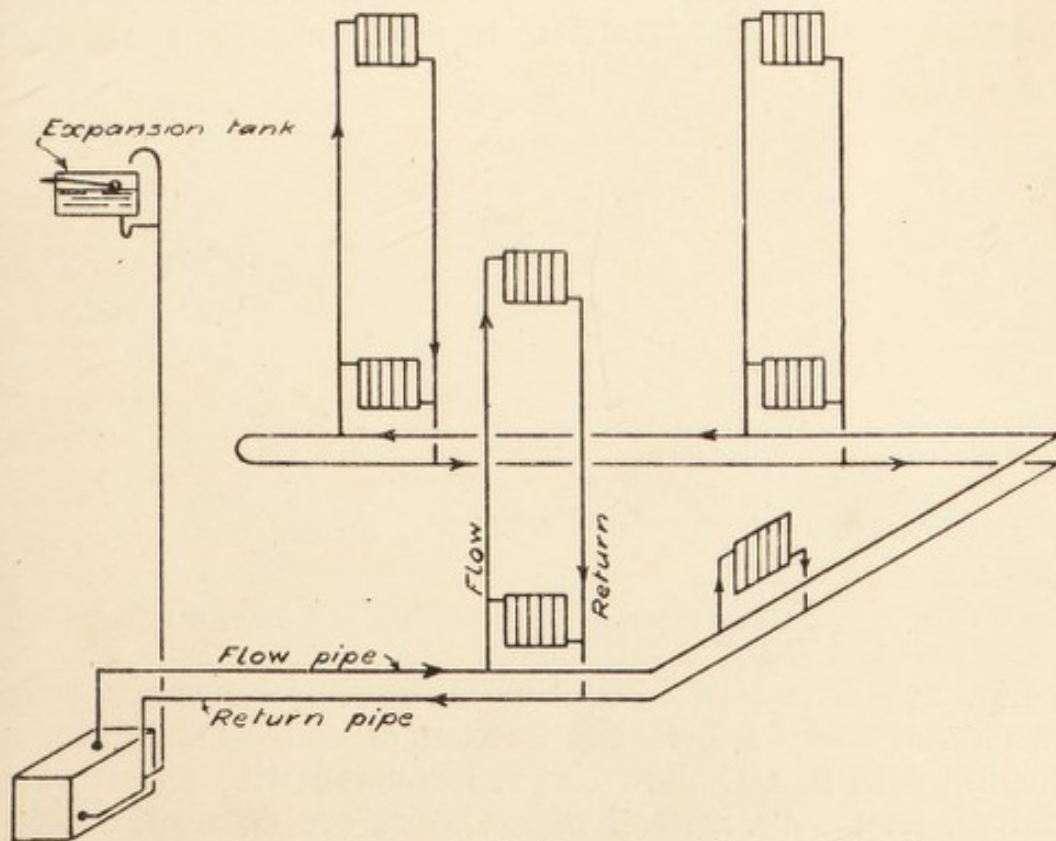

FIG. 23.—Two-pipe underfeed system of central heating.

is built in a furnace instead of having a separate boiler and the expansion of the heated water is provided for by a small expansion chamber like a closed air vessel. A small supply

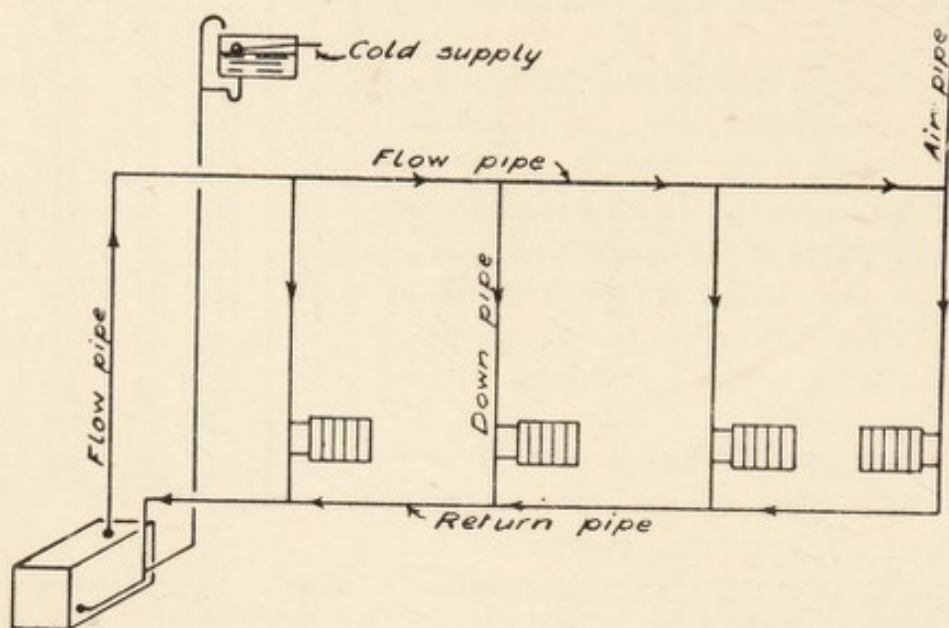

FIG. 24.—One-pipe drop-pipe system of central heating.

tank, controlled by a ball cock and shut off from the pipes when they are in use, makes up, from time to time, any loss that may occur. The arrangement is shown diagrammatically

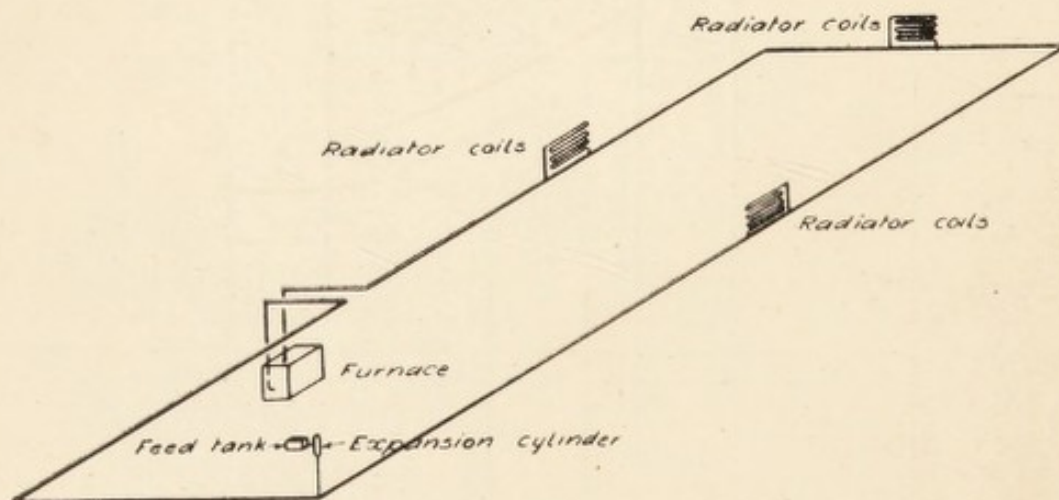

FIG. 25.—High-pressure hot-water heating for churches.

in Fig. 25. The pipe is continued from the furnace round the church and back to the bottom of coil. The pipes are generally laid in a shallow channel covered with a perforated grating; flat coils instead of radiators are connected where

required. The inventor of this system (Perkins) used to say that he could make the water red-hot. Without going so far as that the temperature is sometimes sufficient to char the dust that settles on the pipes and cause an unpleasant smell.

Another method of providing hot water for supply or circulation is by means of a calorifier. This is usually in the form of a coil of wrought-iron pipe through which steam passes (Fig. 26), and placed in a hot-water cylinder it heats the water by conduction. A special high-pressure calorifier arrangement is shown in Fig. 27, where water at a very high temperature travels in a closed circuit through a hot-water cylinder. A is the furnace containing the primary coil, B an expansion

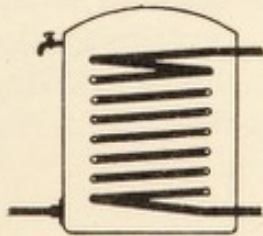

FIG. 26.—Calorifier for heating water by steam.

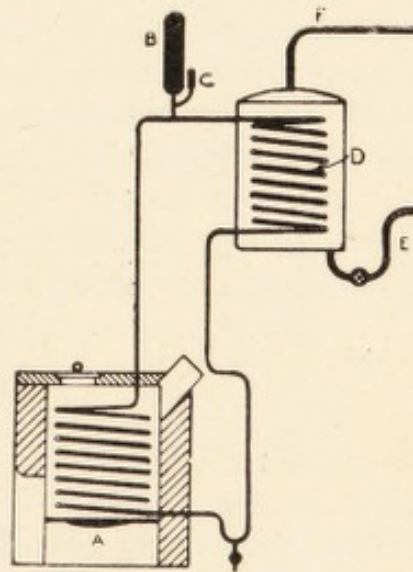

FIG. 27.—High-pressure calorifier.

chamber, C a branch where water may be added at long intervals when required, the system being cold at the time, D the heating coil in the hot-water cylinder, E the cold water supply to cylinder, and F the draw-off for hot water. It should be noted that if the temperature in a boiler or any hot-water apparatus rises above  $180^{\circ}$  F., lime will be deposited and the pipes will be furred up. This is liable to occur when independent boilers are used, but a boot boiler at the back of a kitchen stove will generally be kept within the limit of temperature, and little or no deposit results. The contrast in two cases known to the author is remarkable. A coal merchant complained that his hot-water pipes got choked up and had to be renewed every two years. It was explained that this was because he was a coal merchant, and that the fuel was used

too liberally ; while his informant (an engineer) had similar hot-water apparatus in use for thirty years without renewal.

Warming by steam pipes is not suitable for private houses or general institutions, but has many advantages for factories. Exhaust steam is used for this purpose and the pipes are of cast-iron 4 or 6 in. in diameter. They have to be laid with a good fall owing to the amount of condensation water, and provision has to be made for expansion and contraction.

Warming by hot air is sometimes adopted for large buildings, but it is bad in principle, and is going out of favour. Before the rooms get warmed up the body is immersed in air uncomfortably warm, while the walls are abstracting some of the bodily heat, or as it is sometimes graphically but not scientifically expressed, the walls are radiating cold. On the other hand, when the place is fully warmed up, there is an absence of the occasional changes in temperature which are necessary to brace up the human system. One advantage is, perhaps, that in summer the same arrangement of ducts may be used to convey air that has been cooled by being driven by a ventilating fan through a wet screen.

#### EXAMINATION QUESTIONS RELATING TO CHAPTER IX.

1.—(a) Explain clearly how the air of a room becomes heated by an open fire-place ; (b) how does the interior of a green-house become heated by the sun's rays ?

2.—What is meant by the terms " radiation," " conduction," " convection." Give examples of each as applied to the heating of rooms. Name the various methods of warming large buildings, and describe their advantages and disadvantages.

3.—Name some of the causes of down-draught in a chimney. Why does a fire often smoke when first lighted ?

4.—What are the advantages and disadvantages of each of the following methods of warming a dwelling-room : (a) open coal fire ; (b) closed stove with flue ; (c) flueless gas stove.

5.—State the advantages and disadvantages attending the use of (a) coal, and (b) coal gas, as a heating agent, and describe a fire-place suitable for use in connection with the former.

6.—What are the respective advantages, disadvantages, and dangers (if any) attendant upon the use of (a) open coal fires, (b) slow

combustion stoves, (c) closed coke stoves, (d) gas fires, for warming living-rooms? How may such disadvantages and dangers be best overcome or minimized?

7.—What special precautions are desirable where gas fires are used in dwelling-rooms? What are the advantages and disadvantages of gas fires?

8.—Describe a condensing gas stove and a gas radiator. What are their advantages and disadvantages?

9.—Describe a good form of open fire-place. Compare it with low-pressure hot-water pipes as a means of warming a class-room.

10.—Sketch the cylinder system of heating by hot water, and explain how the circulation is maintained.

11.—Enumerate the various means used for warming interiors of buildings. Explain fully the principle and working of an effective method of using hot water for warming purposes. Give sketches.

12.—What is a suitable temperature for a class-room? By what means can it be most readily maintained in cold weather in all parts of the class-room?

13.—Give arguments for and against heating a small villa by a gas fire in each room in comparison with a hot-water radiator in each room connected up to a gas-fired boiler or circulator. You may assume ordinary coal grates are already fitted in the rooms.

14.—What is the best general method of warming a nursery? Describe how warming results from an open fire, a closed stove, steam-heated pipes. What are the physical advantages and dangers of each?

15.—In a flat, a hot-water circulating system is to be installed from the boiler at back of kitchen range, to supply bath, lavatory basin, and scullery sink. Explain clearly and give sketches of the system which you would recommend.

16.—How should a drying-room for a steam laundry be designed and equipped? Give sketches.

17.—Sketch in diagram form a hot-water system consisting of an independent boiler, water tank, and six radiators, etc., for a lecture hall, showing and naming the various pipes and fittings.

18.—Illustrate, by means of a section through a house, what is meant by the cylinder-tank system of hot-water supply. To what error in workmanship would you attribute the "knocking" or "reports" occasionally heard in such systems? Indicate how this should be prevented.

19.—Show, by sketches, the general principle of an arrangement for supplying hot water to a large house by continuous circulation.

20.—In a large building of five floors, with the staircase and passages at one end, show by sketches how a hot-water heating system should be arranged.

21.—What is the difference in the arrangement of a system for the supply of hot water and a system of heating by hot water? Discuss whether it is practicable or advisable to combine the two services.

22.—Sketch and describe, in detail, an installation to supply hot water for baths, wash-hand basins, and sinks for a block of flats four storeys high, with two self-contained flats on each floor.

23.—Describe the heating of a factory by exhaust steam. What precautions must be taken to avoid fracture of pipes from (a) frost; (b) over-pressure; (c) expansion and contraction?

24.—Describe and show by sketch the best method of heating water for an hotel where a large quantity is required.

25.—In heating a workshop by exhaust steam what provision must be made for (a) expansion, (b) condensation?

26.—Sketch a calorifier system of hot-water supply and explain its advantages.

27.—It is required to heat a large hall with hot water, state the advantages and disadvantages of the "high" and "low" pressure systems and how you would arrange them.

28.—How can a church or chapel seating 500 people, without a gallery, be conveniently warmed? How much should the apparatus be able to raise the temperature of the atmosphere in it, and at what temperature should the interior of the building be kept?

29.—Describe the "plenum" and the "vacuum" systems of ventilating large buildings.

30.—Sketch the section through a "Galton" stove set in a chimney breast and describe how the air is warmed and delivered into the room.

SECTION IV.  
WATER.

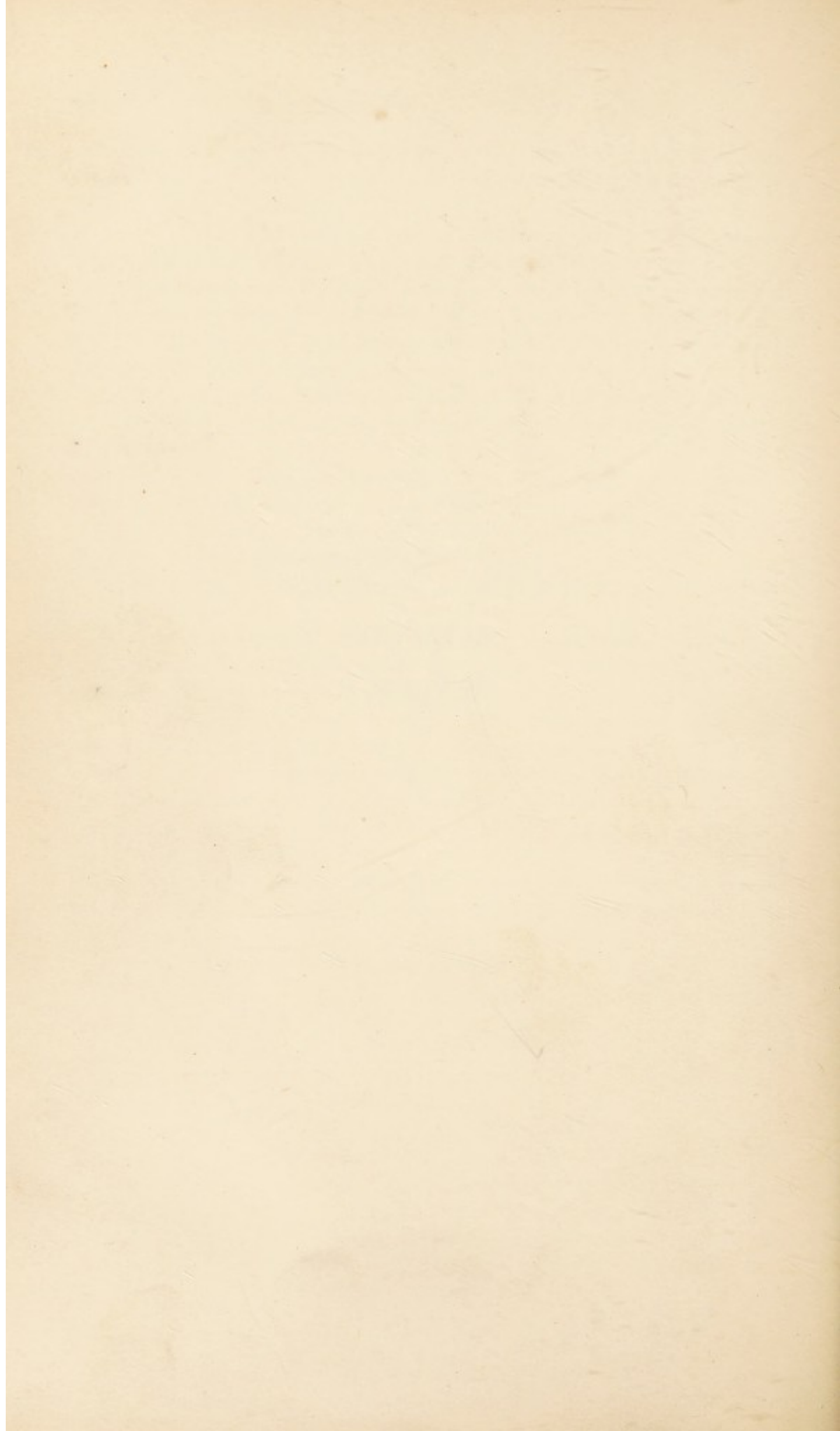

## CHAPTER X.

Sources of supply—Gathering grounds—Measuring the flow of water—  
Physical characteristics of various waters—Impounding, storage,  
and service reservoirs—Filtration, softening and other purifying  
processes.

THE ordinary sources of water supply are: (1) direct rainfall; (2) upland gathering grounds; (3) lakes; (4) rivers; (5) springs; (6) wells.

Direct rainfall may be collected from slated or tiled roofs into water-butts, cisterns, or underground tanks. The water-butt against the wall of a country cottage is a barrel on end raised a foot or so off the ground by an oak frame, brick walls, or blocks of stone, and furnished with a wooden tap in the side, near the bottom. It receives the down pipe from the roof, which should pass through a wooden cover, but the cover is generally missing. The only purification the water gets is that sometimes a layer of charcoal 3 or 4 ins. deep may be found at the bottom of the barrel when the water is required for drinking. This may do for agricultural labourers who, as they say, get "manured" to it, but ordinary people would only use such water for washing. Owing to the fitful rainfall we get in England some such apparatus as Roberts' rain-water separator is desirable for decanting the foul water before passing on the pure water. Many showers are only sufficient to moisten the roof or give a sluggish flow, which is fouled by bird droppings, dust, soot, etc. The illustration shows a vertical Roberts' rain-water separator made of zinc in an iron frame. In Fig. 28 the apparatus is in the position it would occupy at the commencement of a fall of rain when the dirty water passes to waste. The central portion, called the canter, is detached from the upper and lower parts, as shown in Fig. 29, and tips over on a pivot after a predetermined amount of water has passed

through, taking up the position shown in Fig. 30, where the water is passing to storage. The change of position is effected by the gradual accumulation of a small portion of the water in the chamber J of the canter. When the water reaches a certain height it makes the left side heavier than the right, and the canter turns a little on the pivot M that supports it, so that the water is delivered 2 ins. further to the right than it was before, and whereas it at first ran through N into the waste pipe, it now runs through O into the adjoining pipe leading to the storage tank. It will be noticed that the outlet

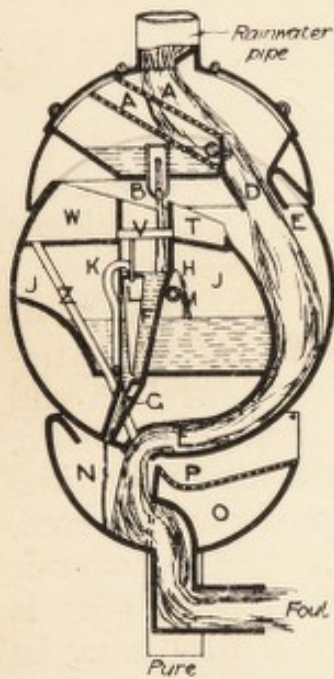

FIG. 28.—Roberts' rain-water separator with dirty water passing to waste.

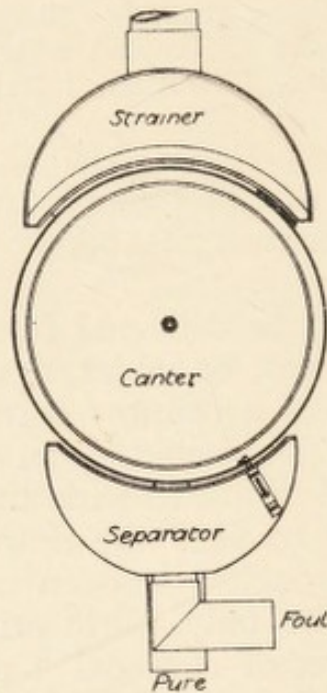

FIG. 29.—Elevation of separator.

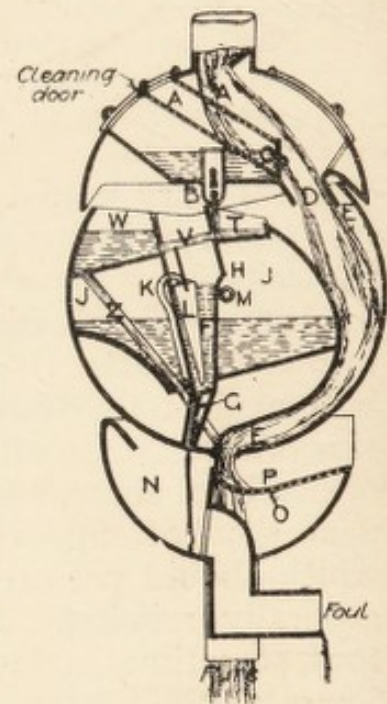

FIG. 30.—Clean water passing to storage.

pipe for the pure water is behind that for the foul, the inlet to the former is from the right-hand side of the apparatus, and the latter from the left-hand side. AA are strainers removable for washing. B is a removable slide with two small holes to regulate the flow of water to the canter. C is a sluice to be adjusted to the area of the roof, and D is the outlet for surplus water. In moderately heavy rain the main volume of the water flows through this spout D into the delivery pipe E, running round the right-hand side of the canter; a small proportion only passes through the strainer and out of the

small holes B into the funnel F that terminates in the small hole G.

In a very slight rain the whole of the water passes through the strainers and the hole B into F, and when it is not enough to wash the roof effectually it all escapes through G without making the canter move. When there is more rain than can pass through the hole G it rises in F and L, and a small quantity runs over the side of the funnel at H, slowly filling the chamber J. When J is filled to a certain height it overbalances the canter and makes the water run to storage through the strainer P and chamber O, as shown in Fig. 30. This change in position causes the water from B to run into T and to cease to run into F. As the water sinks in F it also sinks in L, causing the siphon K to act and empty the chamber J. Meanwhile the little chamber W is partially filled by water running through T, V, W and Z, and its weight prevents the separator from recanting until the water ceases to run from the roof. As soon as W is empty the canter rights itself ready for the next rainfall, the right-hand side of the canter being heavier than the left when it is empty. By means of the joint action of the sluice C and the holes B and G the flow of water in the working part of the separator is so regulated that the chamber J is filled to the canting point as soon as the predetermined quantity of rain necessary to wash the roof clean has fallen, either quickly or slowly. This apparatus may deliver into a covered water-butt, or galvanised iron cistern, or into an underground storage tank, and in the latter case it may be associated with a sand filter. It is only suitable for single houses in the country. For large supplies recourse must be had to some of the other sources named above.

Where rain-water has to be collected and stored, underground tanks may be arranged as in Fig. 31, where the sand filters are in duplicate to allow of one at the time being laid off for cleaning.

Upland gathering grounds are generally situated far from towns where the rainfall is purest and the soil unpolluted; the ideal position is a valley with a bottle-neck or narrow outlet. The "watershed," or limit of the gathering ground, will traverse the crest of the surrounding high ground and mark the area from which the rainfall runs into the valley (see Fig. 32). A dam across the narrow opening will enable the water to be retained in the valley as a storage reservoir until required for

distribution. Fig. 33 shows the general section of an earthen dam, and Fig. 34 that of a masonry dam. Many observations and notes are required before the supply can be determined ;

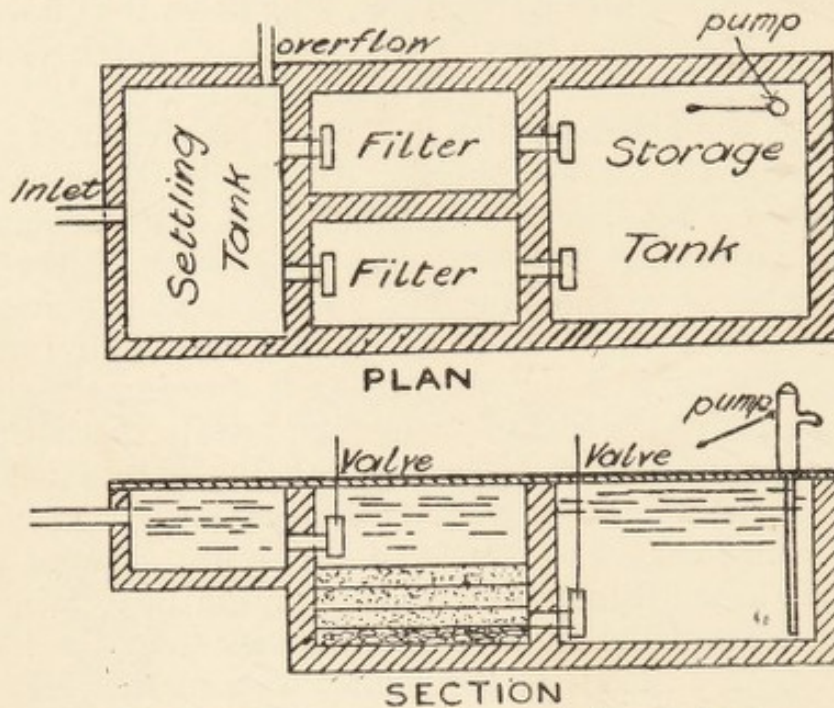

FIG. 31.—Rain-water filter and storage tank.

such as the mean annual rainfall ; the average rainfall for the three driest consecutive years, which may be only four-fifths of the former ; the nature of the subsoil, as a guide to the percolation and evaporation ; and the actual flow from time

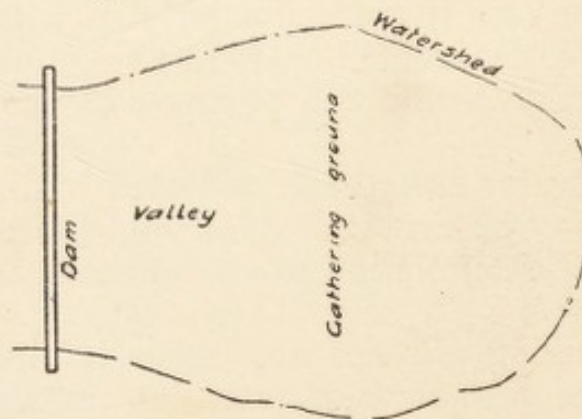

FIG. 32.—Gathering ground for water supply.

to time. There will generally be a small stream running along the bottom of the valley where the flow can be measured. This can be done by means of a gauging weir constructed as shown in Fig. 35. The measuring notch is carefully cut in a

wrought-iron plate, and may be either rectangular, as shown, or a simple V-shape with a 90-degree opening. A stake is driven in the stream some little distance back, where the water has not begun the extra slope due to falling over the weir, and is cut off level with the bottom of the notch. A two-

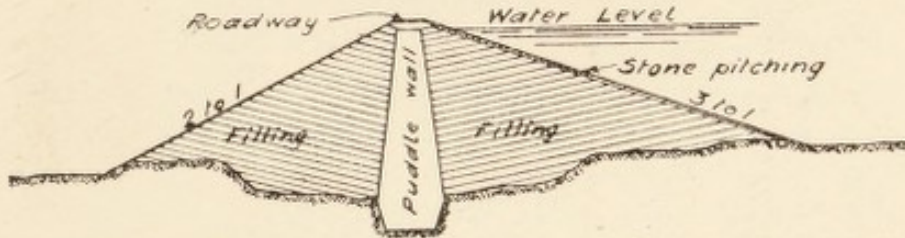

FIG. 33.—Section through earthen dam showing impermeable puddle wall.

foot rule held on the stake will, at any time, show the head of water on the weir. The cubic feet per minute (cumins) flowing over the rectangular weir will be given by the formula  $4.69\sqrt{h^3}$  per foot in width, where  $h$  is the head in inches (Santo Crimp). With a V notch, angle  $90^\circ$ , the flow will be given in cumins

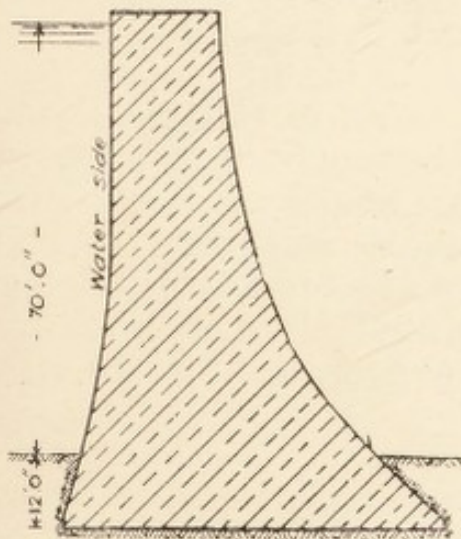

FIG. 34.—Section through masonry dam.

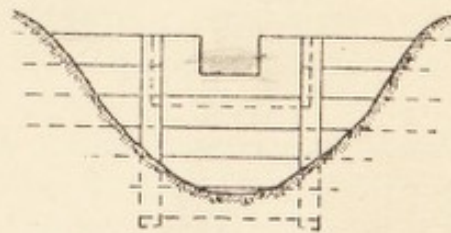

FIG. 35.—Gauging weir or measuring notch.

by  $.321\sqrt{h^5}$  (Professor Alexander). When a gauging weir is not available we have for the flow in a stream—

cusecs =  $\frac{dbl}{.75t}$ , where  $d$  = average depth in feet,  $b$  = average breadth in feet,  $l$  = distance in feet,  $t$  = time taken by float in seconds.

Rivers and lakes as sources of water supply are of very varied value, and all require more or less purification owing to the facility with which they receive pollution. After allowing suspended matter to settle the water is pumped on to an open filter consisting of, say,

Ft.	Ins.					
2	0	washed sand on top.				
	4	gravel passing $\frac{3}{8}$ mesh but retained on $\frac{1}{8}$ mesh.				
	5	"	$\frac{3}{4}$	"	"	$\frac{3}{8}$ "
	6	"	$1\frac{1}{2}$	"	"	$\frac{3}{4}$ "
1	0	"	$2\frac{1}{2}$	"	"	$1\frac{1}{2}$ "
<hr style="width: 20%; margin-left: 0;"/>						
4	3	total depth.				
<hr style="width: 20%; margin-left: 0;"/>						

Over the floor below the large gravel open brick or pipe drains are laid to let the water get away freely. The material is graded so that each layer in its turn may be supported without being washed away or clogging. The top layer of the sand is the efficient part, the action is partly mechanical but more essentially bacterial. A kind of jelly forms on the surface, consisting of bacterial growths which feed upon the impurities in the water. The sand filters are made in units of  $\frac{1}{4}$  to  $\frac{3}{4}$  acre each, to allow for laying them off in turn for cleaning. A head of about 2 ft. of water may be kept on the filter, but the rate at which it flows through must not be allowed to exceed 2 to 4 ins. per hour, according to the depth of sand; 1 in. per hour is about equal to 112 gallons per square yard per 24 hours. Another estimated allowance for sand filtration is 40 to 50 gallons per 24 hours per square foot of area, or two million gallons per acre.

Candy's pressure filters are usually steel cylinders about 8 ft. 3 ins. diameter. They are more rapid in action than the open sand filters but require the water to be chemically treated with sulphate of alumina to produce coagulation. A filter of this size will filter 150,000 gallons in 24 hours.

Domestic filters are seldom required; those containing ordinary charcoal are worse than useless, and some others are of doubtful value. The best are the Pasteur-Chamberland and the Berkefeld. The latter consists of a cylinder or "candle" of kieselguhr, an infusorial siliceous earth, closed at one end and the other end fitted into a metal mount, the whole being in a casing that can be screwed to a scullery tap. The water

flows from outside to inside and then through the small aperture in the mount. The cylinders require periodical cleaning and sterilising, but with the Company's water they will last good some time. They are cleaned by removing the cylinder from the casing, and while holding it under a tap, brushing gently with a piece of loofah or a clean soft brush.

An impounding reservoir, if in a rainy district, should contain not less than 120 days' supply, and in a comparatively dry district not less than 250. On the average only about two-fifths of the rainfall can be taken as available for storage, the remainder being lost by overflow in times of flood, evaporation, absorption, and compensation water. As the impounding reservoir may be a long way from where the water is required, service reservoirs are constructed in the immediate vicinity of the consumers. The capacity should be sufficient to hold at least three days' normal supply to enable repairs and breakdowns to be attended to.

There are several impurities from which drinking water must be purified, and this should be done as near the source as possible, provided no further contamination can reach the water. The water off peat soils is discoloured and contains various organic acids. These are best removed by exposure to sun and air in open reservoirs, but may need to be assisted by the addition of milk of lime. Lead pipes should not be used for soft water in its natural state, but there is no danger after sufficient lime has been added. Lead is a cumulative poison, and is therefore specially dangerous. Water containing iron has an inky taste, chokes up the pipes and stains linen. It is difficult to purify; a simple way is to allow it to fall in a cascade through coke in an aerating tower and then pass it through a sand filter. Water containing carbonate of lime is said to have temporary hardness because it can easily be removed by boiling or by the addition of more lime. The rationale of the process is that water containing free carbonic acid can hold carbonate of lime in suspension, but when the acid is driven off by boiling, or neutralized by the addition of further lime, almost the whole of it is deposited as fur or scale. When the water contains sulphate of lime it is said to have permanent hardness because it cannot be removed by ordinary means. A modern discovery, however, enables this to be done. The Permutit system, by Dr. Gaus of Berlin, removes the whole of the hardness and a small quantity of the unsoftened water is added to

make a suitable mixture. Permutit consists of 3 parts kaolin or china clay, 6 parts sand, 12 parts soda, melted together in a furnace, crushed and washed to remove the alkali, sifted and rinsed to remove the finer particles, and finally dried in a centrifugal machine. It is used in a closed cylindrical vessel like an ordinary mechanical filter and the crude water passed through, which then exchanges its calcium, magnesium, and sulphur for the sodium of the Permutit. When the latter is exhausted it can be regenerated by adding a solution of common salt, which is run off into the drains, leaving the Permutit in its original state to act again. What is called the "natural scale of hardness" is the number of parts of carbonate of lime, or its equivalent, in 100,000 parts of water. "Clarke's" scale of hardness is slightly different: it is the number of grains of carbonate of lime, or its equivalent, in a gallon of water, and as a gallon consists of 70,000 grains, 1 degree on Clarke's scale is 1 part in 70,000. Thus, natural degrees  $\times \frac{7}{10} =$  Clarke's degrees.

The hardness of water can be determined by the quantity of a standard soap solution which is required to neutralize the salts and make a lather. This test is known as Clarke's Soap Test. The method is as follows:—

Take 100 c.c. of water in a burette and from a graduated pipette add small quantities of the soap solution until a permanent lather is formed on shaking. Allowing for, say, 4.8 c.c. of soap solution used, deduct .4 c.c. necessary for lather with distilled water = 4.4 c.c. soap solution necessary for forming permanent lather with 100 c.c. of water to be tested. 1 c.c. = 2.5 mg. of hardness, therefore  $4.4 \times 2.5 = 11$  mg. in 100 c.c. or 11 degrees of hardness (metric scale). To bring this to grains per gallon,  $11 \times 0.7 = 7.7$ , i.e. 7.7 grains of hardness (Clarke's scale) or 7.7 grains mineral matter per gallon. Water is called soft when it has not more than 5 or 6 degrees of hardness, with 10 or more degrees it is called hard water. London water has about 17 degrees of hardness. Water is softened by adding 2 oz. quicklime per degree of hardness to every 1000 gallons. For domestic use hard water is softened by the addition of soda, 4 lb. of soda having as much effect as 1 cwt. of soap. The disadvantage of hard water for domestic purposes is that each degree of hardness destroys 1 oz. of soap in 40 gallons of water. Standard soap solution is made by mixing soft soap with distilled water of such strength that 1 c.c. neutralizes

1 degree hardness in 50 c.c. of sample, and anything beyond produces a permanent lather. A better method is to use pure Castile white soap sliced up thin, dissolved in a little warm water with a few drops of alcohol to preserve and assist the solution. Allow to settle. Filter it, dilute with distilled water until it does what is required when tested on a specially prepared hardness solution.

The water from lakes and rivers is very likely to be polluted and must undergo purification. Organic impurities are partially got rid of by sand filtration, but reliance cannot be placed on this, and some method of chlorination is now universally adopted, commonly the addition of bleaching powder ( $\text{CaOCl}_2$ ) or oxychloride of lime. Although called a chlorine treatment it is in reality an oxidation, the bacteria being destroyed by the nascent oxygen set free in contact with oxidisable matter. The organic impurity of water is generally estimated by the number of *bacillus coli* (*B. coli*) in a cubic centimetre. For example, not more than 100 *B. coli* per c.c. would indicate a good drinking water, 500 a suspicious water, and 1000 or more a bad water. The *B. coli* is taken as an index of the impurities because it resists disinfectants and germicides better than ordinary disease germs will do, and, therefore, if only a few of these are left there is not likely to be a dangerous number of the others. Water-borne diseases are cholera, enteric (typhoid), dysentery, etc. The simplest way of sterilizing water in small quantities is to boil it, or to add 15 grains bisulphate of soda per pint. A rough test for organic matter is to take a decanter partly filled with the water, put the hand over its mouth, shake it up well, and then smell it; or a grain of permanganate of potash dropped in will turn the water a rusty colour if impure but leave it a fine purple if pure.

Wells may be surface wells or deep wells (see Fig. 36). They are usually built in brickwork and surrounded by puddled clay for a certain distance down to shut out surface water and probable pollution. Shallow wells should always be looked upon with suspicion, and special care should be taken in selecting the site. A deep well is not necessarily artesian. An artesian well (Fig. 37) is generally formed by driving a tube down where the lower strata lie in the shape of a basin so that the water rises up by hydraulic pressure above the mouth of the well. The top of a well should be protected by a wooden cover, the brickwork supporting it being carried up at least 6 ins. above the ground,

The water from wells, even deep artesian wells, must be analysed by a chemist and tested by a bacteriologist before it can be pronounced fit for drinking. In deep wells the surface water is shut out by brick steining with puddled clay at the back, or by cast-iron tubing; or where a small supply only is required, by wrought-iron tubes driven down. The water from surface wells should be used as a last resource, and for safety should always be boiled before use. Farmers have been known to sink a surface well in the corner of the farmyard, and prefer the water to London water because it had more "flavour" in it.

The depth of a well may be estimated approximately by the time a stone takes to reach the water when dropped from the surface. A stone, like any other falling body, is accelerated

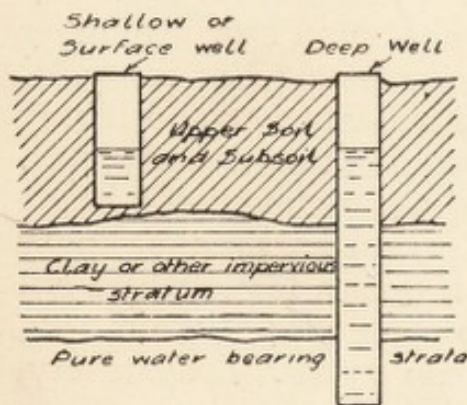

FIG. 36.—Distinction between shallow and deep wells.

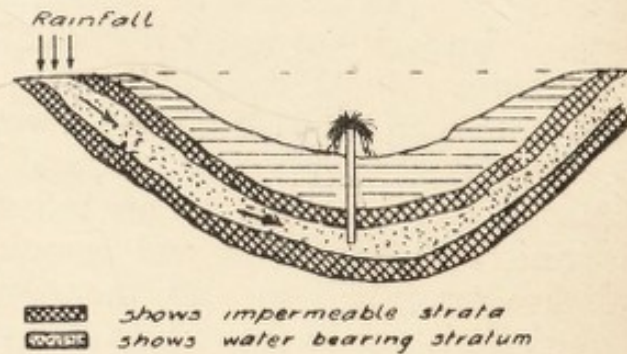

FIG. 37.—Section through strata showing artesian well.

by gravity at the rate of 32 ft. per second, per second =  $g$ , therefore the depth fallen would be roughly  $\frac{1}{2}gt^2 = 16 \times \text{time in seconds squared}$ . The sound travels at the rate of 1120 ft. per second, and this is so quick compared with the rate of fall that no addition need be made to allow for it, and the time in seconds the sound takes to reach the ear after the stone is released from the hand may be used in the calculation. When water is pumped from a well a "cone of depression" is formed in the surrounding strata, as the water cannot flow from a distance quickly enough to replace that in the well as fast as it is withdrawn. This may lead to a sinking of the water level in adjacent wells, but there is no "property" in underground water unless running in defined channels so that no compensation can be obtained from the owner who has the deepest well.

The yield of a well may be ascertained as follows: Set a pump working by hand or steam power, note the level of the water at intervals, when the level ceases to fall note the strokes of the pump in a given time, calculate from the diameter and stroke of pump and strokes per minute the quantity of water raised in 1 minute, multiply by 60 minutes and allow 5 per cent. for losses to obtain the yield per hour. A larger pump or quicker strokes might show that there is a greater yield than the first test would give. It is essential that the water level should cease to fall when the calculation is made.

#### EXAMINATION QUESTIONS RELATING TO CHAPTER X.

1.—Show by sketch plan and section a 1000-gallon rain-water tank below the surface of the ground. If the water is to be used for domestic purposes what precautions must be taken in collecting it?

2.—Give some of the characteristics of water obtained from (1) an upland watershed; (2) a deep well in chalk stratum.

3.—State fully the various sources of water supply for domestic purposes of a town, together with the characteristics of the water obtained from each source.

4.—What are the best sources for drinking water? What sources of water are suspicious, and from what sources is dangerous water likely to be obtained?

5.—What are the physical characteristics of good drinking water? Is it possible to declare any water fit for use on these characteristics alone? If not, state any other requirements that should be complied with.

6.—Describe the construction of sand filters for the water supply of a town of 20,000 inhabitants. Specify dimensions, materials used, and rate of flow. Answers should be illustrated by sketches.

7.—Make a section through a sand filter bed with dimensions, and state the use of the various layers. Mark the level of the water and the direction of flow.

8.—What sources of water supply are you likely to find in a flat country, and how would you utilise them?

9.—Assuming the water supply to a house to amount to 15 gallons per head per day, what quantity would be available for each of the principal domestic uses?

10.—When rain-water falling on the roof forms the only source of

supply for domestic purposes, how can it be collected, and what precautions must be taken?

11.—It is proposed to utilise the water flowing down a valley for a town supply. Describe how you would ascertain (*a*) the quantity required; (*b*) the quantity available.

12.—Describe the biological action of sand filtration on a large scale, and how the efficiency of the filter is maintained.

13.—Lime being one of the constituents of "hardness" in water, explain how water is rendered less hard by the addition of lime.

14.—Describe the simple tests (other than chemical analysis) that can be applied to water to ascertain if it is polluted.

15.—Mention the different kinds of well from which drinking water is obtained. Describe the construction of each kind and the principal points to be considered in deciding upon the position of a well.

16.—If asked to advise as to a new water supply for a small township from upland waters one mile distant, enumerate the general points you would take into consideration.

17.—Discuss the meaning of the words "hard" and "soft" as applied to water, and the causes that give rise to these conditions. If it were required to use a river water for drinking and domestic purposes, describe the methods which might be suggested for its (*a*) storage, (*b*) softening, and (*c*) purification.

18.—What diseases may be spread by impure water, and how may water become impure?

19.—Describe what you consider the best process for softening hard water derived from the chalk formation.

20.—In what circumstances is it desirable to use a filter in a house? What kind of filter would you recommend for this purpose?

21.—What volume of water would be available per day, by direct collection from the roof of a house in the country? The roof is 100 ft. by 50 ft.; the average rainfall is 36 ins. per annum; and the loss by evaporation 9 ins. per annum. What kind of water would be available? Show by sketches the general arrangement for storage and distribution.

22.—How would you estimate the quantity of water likely to be obtained in a tract of country to be used as a gathering ground?

23.—What do you understand by (*a*) permanent hardness of water, and (*b*) temporary hardness? In a supply drawn from bore holes in a limestone district what would you anticipate as regards hardness? State briefly how you would treat such a supply.

24.—Give a sketch showing a water cistern properly fitted up in the roof of a house, and explain the details of the arrangement.

25.—What chemical action takes place when lime is added to hard water for the purpose of softening it? Describe fully a process for softening hard water. Illustrate by sketches.

26.—Of what materials should cisterns be constructed which are intended for the storage of water for dietetic purposes? Give your reasons.

27.—How do you ascertain the velocity of a stream (1) at the surface; (2) below the surface?

28.—Given a conduit in a straight line having clear water flowing 4 ft. in depth and 24 sq. ft. area in cross-section, with a maximum central velocity of 35 ft. per minute, state the number of gallons passing down in 24 hours.

29.—Give a description of the different methods of gauging the flow of water and the formulæ used in connection therewith.

30.—What is the discharge in gallons per minute, through a right-angled triangular notch gauge, the height of water above the bottom of the notch being 3 ins.?

31.—Describe how you would make a standard soap solution for testing the hardness of water.

32.—When a town is to be supplied with water from gathering grounds, how is the available quantity estimated?

33.—Show by sketches what is meant by the "cone of supply" to a well, and explain how variations in the outline are caused.

34.—Describe briefly how domestic water-filters are made and cleaned. Sketch the best kind you know.

35.—Sketch to scale of  $\frac{1}{4}$ -in. = 1 ft. an arrangement of settling tank, filter beds, and pure storage capable of supplying 600 gallons per 24 hours.

36.—A volume of water flowing over a 20-ft. weir is found to be 12 in. deep on the sill (measured 3 ft. back). How deep would this volume of water flow in an open channel 1000 yds. long, 20 ft. wide, with a gradient of 1 in 500? The channel is rectangular in shape, the bottom formed of clay puddle and sides of slag.

37.—Describe methods of chlorination suitable for application in the case of the water supply of (a) a large town; (b) a farm house obtaining water from a well liable to pollution.

38.—What is a shallow well? If a water supply for a village had to be obtained from such wells, what points would you attend to as to site and construction?

## CHAPTER XI.

Requirements and supply of towns, villages, country houses, cottages—  
Mains, pipes, fittings, and storage—Sources of contamination and  
protective precautions—Taking samples for analysis.

THE average quantity of water required per head of population  
per day may be taken as follows :—

	Gallons.
For cooking purposes . . . . .	0·75
For drinking purposes . . . . .	0·33
For ablution purposes . . . . .	3·00
Share of utensil and house washing . . . . .	2·92
Share of clothes (laundry) washing . . . . .	3·00
<hr/>	
Total in Rural Hamlets . . . . .	10·00
If water-closets are in general use add . . . . .	5·00
<hr/>	
Total in Country Villages . . . . .	15·00
If fixed baths are in general use add . . . . .	5·00
<hr/>	
Total for Domestic Purposes . . . . .	20·00
Add for street watering, sewer flushing, and other public services . . . . .	5·00
<hr/>	
Total in Residential Towns . . . . .	25·00
Add for trade purposes . . . . .	5 to 10
<hr/>	
Total in Manufacturing Towns . . . . .	30 to 35

The smallest practical supply is considered to be 15 gallons per head per day through a 3-in. main. The mains must, of course, be calculated to give the required quantity of water at different points along the route. They must be designed to supply half the total daily flow in 6 hours to comply with the requirements during the busy hours, and must also provide a minimum of 150 to 200 galmins for 30 minutes for fire extin-

guishing purposes ; suitable hydrants must be placed at intervals. The mains are usually cast-iron socket pipes with metallic lead joints, as in Fig. 38. Formerly, after the socket was pushed home some gaskin (spun yarn) was driven in, a clay band put round the pipe in front of the socket, leaving a cupped space at the top for pouring in molten lead which was afterwards caulked to make up for the shrinkage in cooling. When any moisture existed in the joint the lead was apt to blow out and injure the workmen, the caulking also was inefficient because the consolidation was not able to penetrate deep enough into the joint and leakage was apt to occur. Now lead wool is the material mostly used, that is, lead in fine threads or shavings, which can be caulked while the jointing is in progress and so made solid throughout without any of the dangers attending molten lead.

The cast-iron pipes are usually protected against corrosion by being coated internally and externally with Dr. Angus Smith's composition, consisting of, say,  $3\frac{1}{2}$  barrels coal tar,  $\frac{1}{2}$  barrel coal oil, and  $\frac{1}{2}$  barrel pitch. This is sometimes heated in a tank, and the pipes, also heated, are dipped in, but there is no necessity to heat the tank, which is dangerous. A more modern method is to heat the pipes, laid on old rails over a wood fire, until they are about  $212^{\circ}$  F., and then dip them in the mixture, afterwards raising them at one end to drain and dry. This forms a black enamel which reduces the internal friction and the liability to corrosion. Small ironwork may be protected by the Bower-Barff process, which consists of raising the articles to a red heat ( $1200^{\circ}$  F.) and subjecting them for 5 or 6 hours to the action of superheated steam, which causes the deposit of a coating of black oxide of iron. The exterior of pipes and other ironwork may be coated with Bitumastic, Siderosthen, or other bituminous compound. Pipes should never be laid in ashes as they corrode the metal very rapidly.

Another favourite form of joint is the turned and bored spigot and socket, as in Fig. 39, the machined surfaces being shown by a thickened line. Less common forms of joint are the flanged joint (Fig. 40), and the turned, bored, and flanged joint (FIG. 41).

The mains should be laid at a minimum distance of 2 ft. 6 ins. to the top of the pipes below the surface of the ground to protect them from frost, and stop valves must be inserted at intervals to shut off any branch in case of repair being

necessary. There are many fittings in connection with water mains, such as sluice stop valves, single or double air valves, fire hydrants, according to circumstances. Fig. 42 shows a fire hydrant in connection with a sluice valve. The house connections are made by tapping  $\frac{1}{2}$ -in. brass unions into the top of the cast-iron pipes wherever they are needed, and wiping lead pipes on to them. A stop cock must be placed on the service pipe just outside the boundary of the premises with a tube and cover so that it can be opened or closed by a box spanner at any time. Another cock should be placed on the pipe directly it enters the house so that it may be quickly shut off

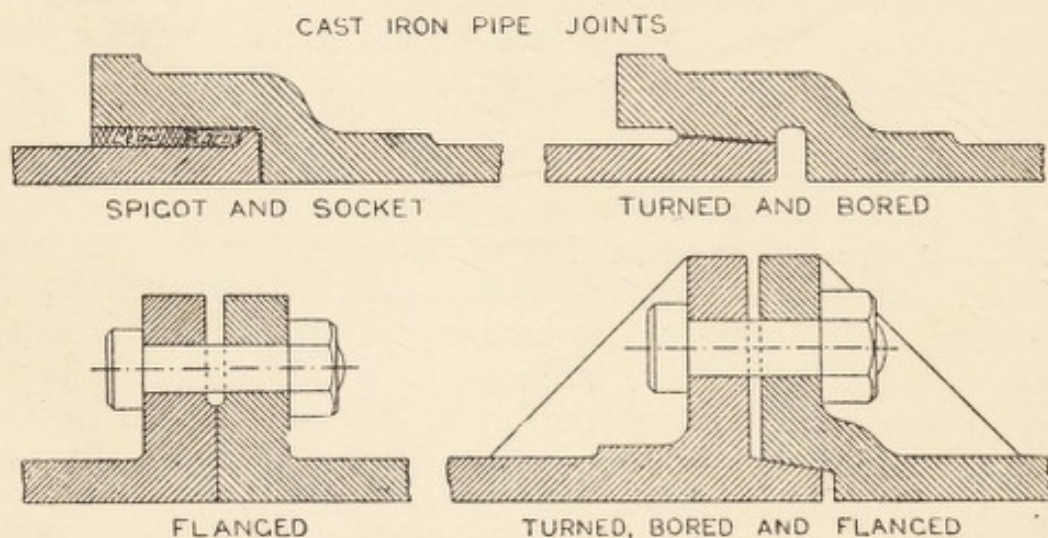

FIG. 38.—Spigot and socket joint in cast-iron pipes.

FIG. 39.—Turned and bored spigot and socket joint in cast-iron water pipes.

FIG. 40.—Flanged joint in cast-iron pipes.

FIG. 41.—Turned, bored and flanged joint.

in case of a burst pipe during a frost. Inside the building the pipes are generally led in any convenient direction to the supply cistern, but if against an outer wall a board should be placed between as a partial protection against frost, and when horizontal they should be supported by wall hooks sufficiently close to prevent sagging. Glass-lined or tin-lined pipes are recommended for soft waters, but seldom seen except as curiosities of manufacture. House cisterns may be of galvanized iron, or of wood lined with lead or zinc. If the water is soft they should be limewhited inside. The supply to the cistern is through a ball cock (Fig. 43), and an overflow should be provided 3 ins. from top of cistern leading to any point where an overflow

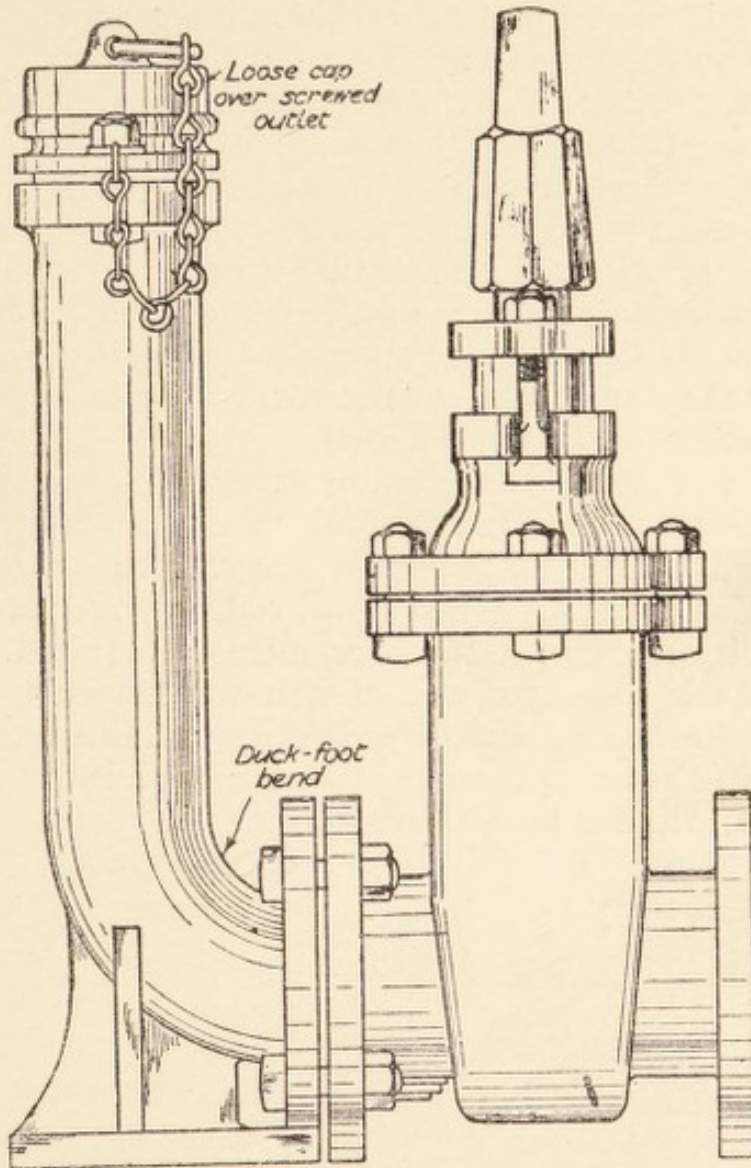

FIG. 42.—Fire hydrant with sluice valve.

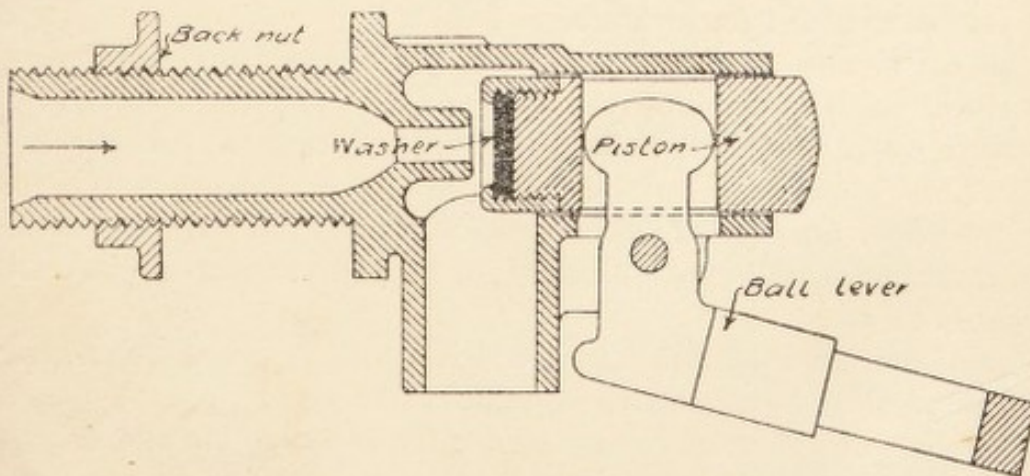

FIG. 43.—Section through cistern ball-cock.

would be noticed, and preferably where it would be a nuisance. The supply to the house should be fixed in the bottom of the cistern so that the opening can be easily plugged by the tapered end of a broom-handle with a piece of rag bound round it while renewing washers on any of the taps. Where a constant water supply is available cisterns are sometimes omitted. The W.C.'s must in all cases be supplied from 2 to 3 gallon waste preventer cisterns with their own ball-cock and overflow; the rate of discharge should be 2 gallons in 5 seconds. Water pipes and fittings should be in accordance with the Ministry of Health Model Specification (price, 3d. net).

No contamination of the water should be possible after it has once been purified, and the only likely source is when the house cistern is unprotected by a cover. An airtight cover, as is sometimes specified, is absurd, only a cover to keep out dust and dirt and small birds or mice is required. In one house that was inspected the cistern was under the floor of the servants' bedroom, and contained several dead beetles and gelatinous growths. At another house the cistern was large and shallow, without any cover, forming the roof of an outside W.C. and contained a dead cat, among other things that should not have been there.

#### EXAMINATION QUESTIONS RELATING TO CHAPTER XI.

1.—Enumerate the various sources from which towns may obtain their water supply. What quantity per head per day do you consider should be provided for an industrial town?

2.—Advise as to the necessity for providing a covered reservoir for the storage of drinking water in the case of: (a) upland water; (b) river water; (c) well water; and give the reasons for any advice offered.

3.—What are the physical characters of good drinking water? Are these sufficient to ensure safety; if not, what other conditions are essential?

4.—Describe a scheme under which a village might be efficiently and economically served with a public water supply.

5.—Describe the best conditions for the construction of a drinking-water cistern.

6.—A town water supply is given as 40 gallons per head per day. How would you divide this up into its various uses?

7.—A river is slightly polluted by the discharge of sewage into it from a village. Describe the self-purifying action which takes place in the river during its flow after contamination.

8.—If you were called upon to examine and to report upon a stream flowing through a district that was complained of as being polluted, what would be your mode of procedure?

9.—Assuming that a large reservoir is filled with filtered water, describe the various ways in which the water may become polluted (*a*) in the reservoir, (*b*) in its passage through the mains, (*c*) when stored in house cisterns, and (*d*) in supplying the various draw-off taps in a house.

10.—What is the average quantity of water required per head of population in a non-manufacturing town? Show how the amount is made up for various uses.

11.—From what sources may drinking water become contaminated (*a*) before entering the house, (*b*) after entering the house?

12.—Describe a town water supply and services to the houses, from reservoir to the scullery sink tap. State approximate diameters of pipes, and also the precautions taken to prevent injury to the pipes by frost, and contamination of the water by sewage, coal gas, etc.

13.—Give a description, with sketches, of any pressure filter for treating water in large quantities.

14.—Describe how water is conveyed from the main in a street into a house. State the usual diameter of the pipe and the reasons why water pipes in a house should not be buried in walls or solid floors.

15.—Sketch full size the section through one side of the socket of a 6-in. water main, showing the joint fully made.

16.—What are the important details requiring attention in taking a sample of water for (*a*) chemical examination, (*b*) bacteriological examination.

17.—What are the chief characteristics of a good public water supply?

18.—If the water supply acted upon the lead pipes in a small town, what would you recommend in order to prevent any danger to health from such supply?

19.—A bucket measures 12 ins. high, 12 ins. diameter at top, 9 ins. diameter at bottom—all inside measurements. How many gallons will it hold?

20.—What are the characteristics of good drinking water (*a*), physical, (*b*) chemical, (*c*) bacteriological?

21.—Mention four sources of water supply in order of purity. How can impure water be improved?

22.—Describe the various methods of obtaining drinking water in villages. State the difficulties connected with each method, and explain how they may be met.

SECTION V.  
DRAINAGE, SEWERAGE, AND SANITARY  
APPLIANCES.

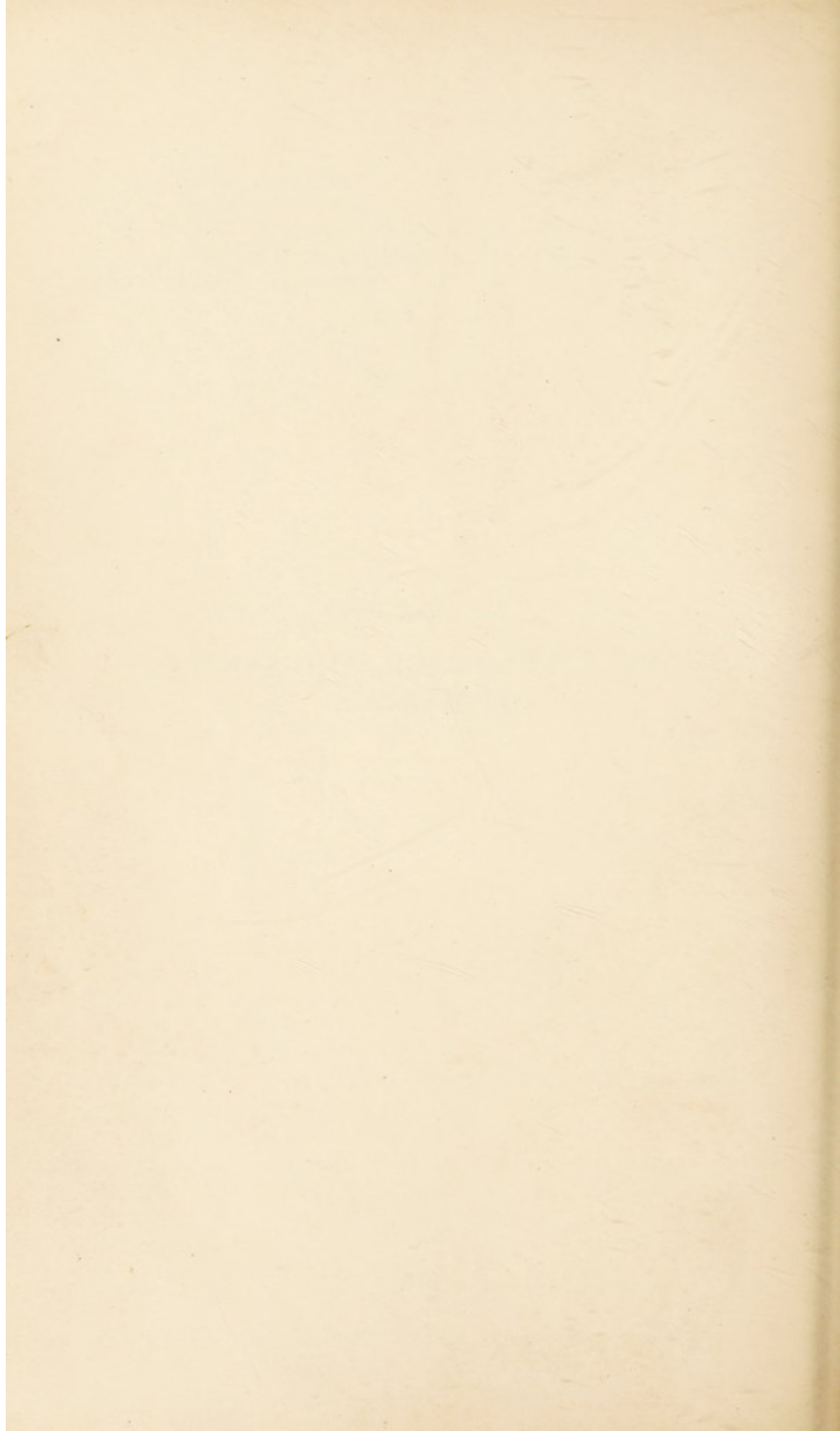

## CHAPTER XII.

The proper conditions of good drainage—Re-modelling old drainage—  
The planning and construction of new drains and sewers—Disposal  
of surface and rain water.

A GOOD drainage system is one where all liquid refuse is removed promptly without causing any nuisance, and is not likely to get out of order. Soil pipes should pass at once from the trap of the W.C. to the outside and be carried down to the drain without any intermediate trap, at the same time the pipe should be continued upwards to form a ventilation outlet 3 ft. above the eaves and 6 ft. away from any window, or better, 18 in. above the ridge, with a wire balloon on the top to prevent birds nesting there. Anti-siphonage pipes should be fixed to every W.C. trap below the topmost one, and the air pipe carried up alongside the soil pipe. It may join in to the soil pipe above the highest trap. The soil pipe should not be less than 4 ins. diameter, and the air pipe 2 ins. The rain-water pipes should on no account be allowed to ventilate the drains, they should discharge over a gully trap. The trap often has a small brick-on-edge wall, built round to retain the water, but this is also apt to retain dead leaves, which choke the grating and make matters worse. Where there are many leaves about it is better to discharge into the trap below the grating and have no projection raised round it, the leaves then dry and are blown off or are more easily swept off. If it is necessary to make a bend in running a drain pipe it is better to build a turning chamber, which is a brick pit 2 ft. square, with a half channel in the bottom, so that no stoppage can take place there, and if any stoppage should occur in the pipes they can be rodded from the chamber. The branches from rain-water gullies should enter at an acute angle by means of a Y-junction. Before the drain leaves the premises it should pass through

a disconnecting chamber, inspection chamber, or manhole (Figs. 44 and 45), with half-channel pipes laid in concrete in the bottom, the sides benched up so that no refuse can settle on them. All side discharges into the manhole should come in at an angle in the direction of the flow, and the outgo should be through an intercepting trap with cleaning eye. Fresh air should come in through a mica flap inlet near the manhole, so that it may pass up and ventilate the drainage system through the soil pipes to the outlet above the roof. Outside soil pipes may be of cast-iron or lead—the former is less liable to damage. Inside soil pipes must be of lead with carefully made joints so that there is no possibility of leakage. The waste pipe from a bath generally discharges into a hopper

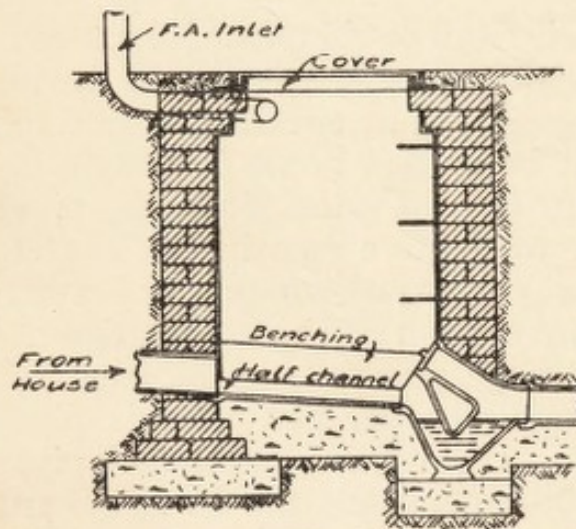

FIG. 44.—Longitudinal section through disconnecting manhole.

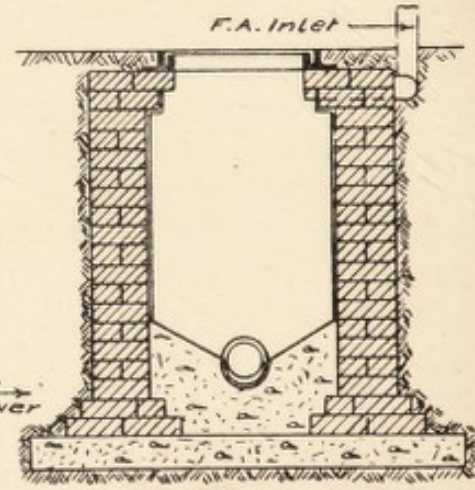

FIG. 45.—Cross-section through same.

head on a down pipe with a bent foot, or shoe, over or under the grating of a gully trap, but it is better practice to treat the bath waste the same as a W.C. outgo, joining it directly into the outside pipe, which should be carried above the roof and finished like the soil pipe. A scullery waste, according to some by-laws, must discharge into a channel 18 ins. away from the gully, but this is unnecessary, as the gully is trapped. A grease trap is not required for an ordinary dwelling-house, although usually necessary for hotels, institutions, and hospitals. There are many varieties; the simplest have a removable perforated tray in an intermediate chamber where the congealed grease collects, as Fig. 46.

In remodelling old drainage many defects will be found,

and it may be necessary to take out the old system entirely and replace it on modern lines. It is difficult to lay down general rules for such cases, but where the proper requirements are known they should be strictly followed.

In planning new drains a ground floor plan of the building should be obtained to a scale of, say,  $\frac{1}{8}$  in. to 1 ft., with the position of all sanitary fittings marked on it, including rain-water down pipes. The course of the main drains and branches, turning chambers, gullies, manholes, and disconnecting chamber should then be set out, with a section showing the fall of the drain. Full descriptions should be written on the plan. Glazed socketed stoneware pipes, 4 ins. diameter, are sufficient for all ordinary houses, although 6 ins. may be required for hotels and groups of houses. They should be laid with such fall that the liquid will run with a self-cleansing velocity, say 1 in 40 for

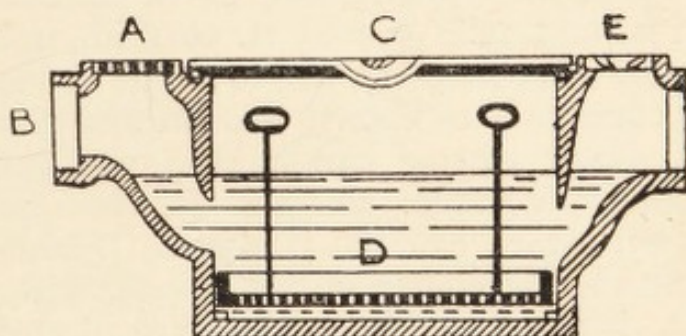

FIG. 46.—Hellyer's grease trap.

4-in. pipes, 1 in 60 for 6-in. pipes, 1 in 90 for 9-in. pipes, but above that the same rule would give too great a velocity, and with a small flow solids might be left behind just as readily as if the fall were insufficient. A good rule for drains of all diameters is that they should be laid to give a velocity of 4 ft. per second. Surface and rain-water may be led into the ordinary soil drains; or in some towns may be led into a separate system of drains, provided to relieve the sewage disposal works; or in the country may be led into a "soak-away" pit, a simple hole filled with broken bricks, large gravel, or chalk rubble, the size of the hole being proportioned to the quantity of water to be disposed of.

The sanitary accommodation required is: For workshops, males, W.C.'s 1 in 25 up to 100, 1 in 40 for remainder up to 500, 1 in 60 over 500, with sufficient urinals; for females, 1 in 25. Entrances to be separate and not visible from each other,

external ventilation essential and cross ventilation of lobby desirable. For boys' schools, 1 in 40 ; for girls' schools, 1 in 25. For mixed schools :—

Total Number in School.	For Girls.	For Boys.	For Infants.
30	2	1	2
100	5	3	4
200	7	4	6
300	8	5	7

For hospitals one W.C., bath, and lavatory basin for every twelve beds.

In planning a sewerage scheme for a town or village it is necessary to obtain an Ordnance map of the district on the  $\frac{1}{2500}$  scale =  $25\frac{1}{3}$  ins. to 1 mile =  $208\frac{1}{3}$  ft. to 1 in., upon which to lay it out, and a  $\frac{1}{10580}$  map = 6 ins. to 1 mile = 880 ft. to 1 in., to study the contour lines shown thereon and also the levels. Then a preliminary scheme can be laid out and the route measured, the levels taken, and the drawings prepared. A tracing from what they call the "25-inch Ordnance map" is made, upon which the course of the sewers, with position of manholes, etc., is shown. The sections are plotted to a horizontal scale the same as the Ordnance map and a vertical scale of 10 ft. to 1 in.; the sewers and manholes are marked thereon with the gradients and levels. Black line photo prints are made from the tracings, the sections coloured and the sewers marked on in red. All the manholes are numbered, and special drawings are made to show their construction.

A standard oval sewer has a height of one-and-a-half times the diameter, the radius of the crown being half the diameter, the radius of the sides one-and-a-half times the diameter, the radius of the invert one-quarter diameter. The approximate hydraulic mean depth (H.M.D.) =  $\cdot 33$ , and the sectional area =  $1\cdot 15d^2$ . The method of setting out is shown in Fig. 47, and the working section in Fig. 48. It will be seen that the invert is composed of a glazed stoneware block which is more lasting than brickwork. The mean velocity of flow in an oval sewer running two-thirds full is greater than the mean velocity when running full owing to the excessive proportion of wetted perimeter in the latter case. If sufficient fall cannot be obtained

for the sewage to run at a self-cleansing velocity in any length of sewer, a Field's flushing cistern, as Fig. 49, should be fixed

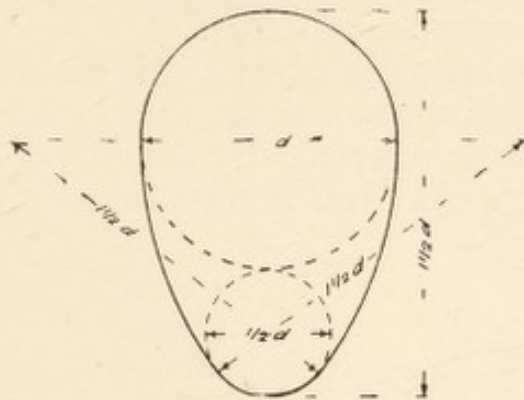

FIG. 47.—Method of setting out standard oval sewer.

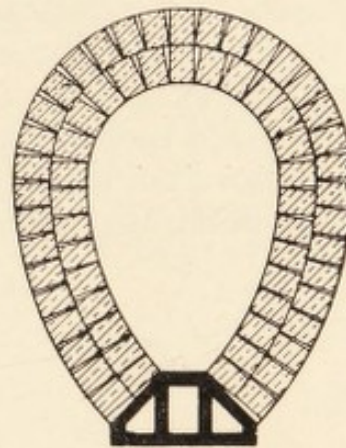

FIG. 48.—Working section of same.

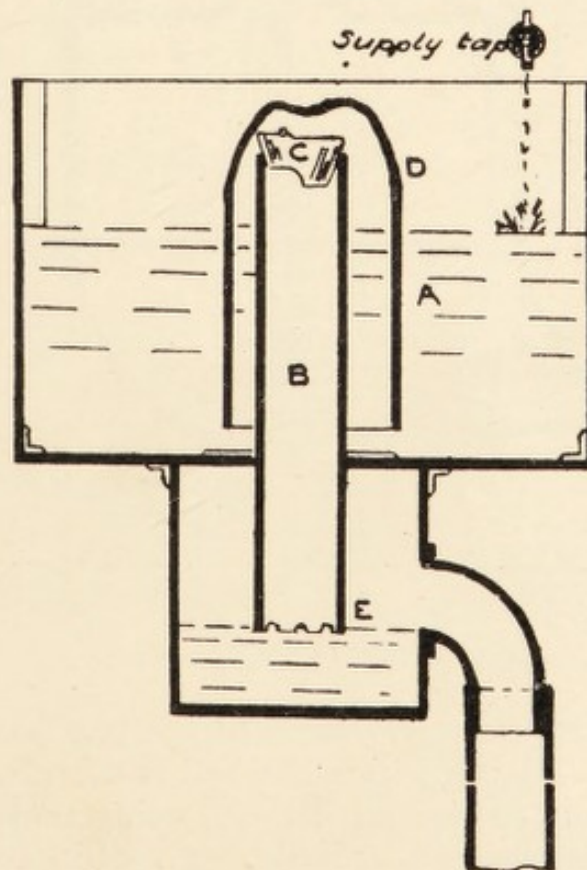

FIG. 49.—Field's flushing cistern for flat sewers.

at the head, with a water supply set to fill the cistern every hour or any other suitable period. In the figure A is the cistern, B the discharge pipe, with the fitting C at the top to cause the

water to drip down the centre when the siphon begins to act, D the bell, equivalent in its use to the short leg of a siphon. The capacity of the flushing cistern in gallons may be 100 times the sectional area of the sewer in square feet.

In planning the sewerage for a flat district it is often necessary to provide means for lifting the sewage to a higher level at one or more points. This is conveniently done by a Shone ejector, as illustrated in Fig. 50. The sewage enters through

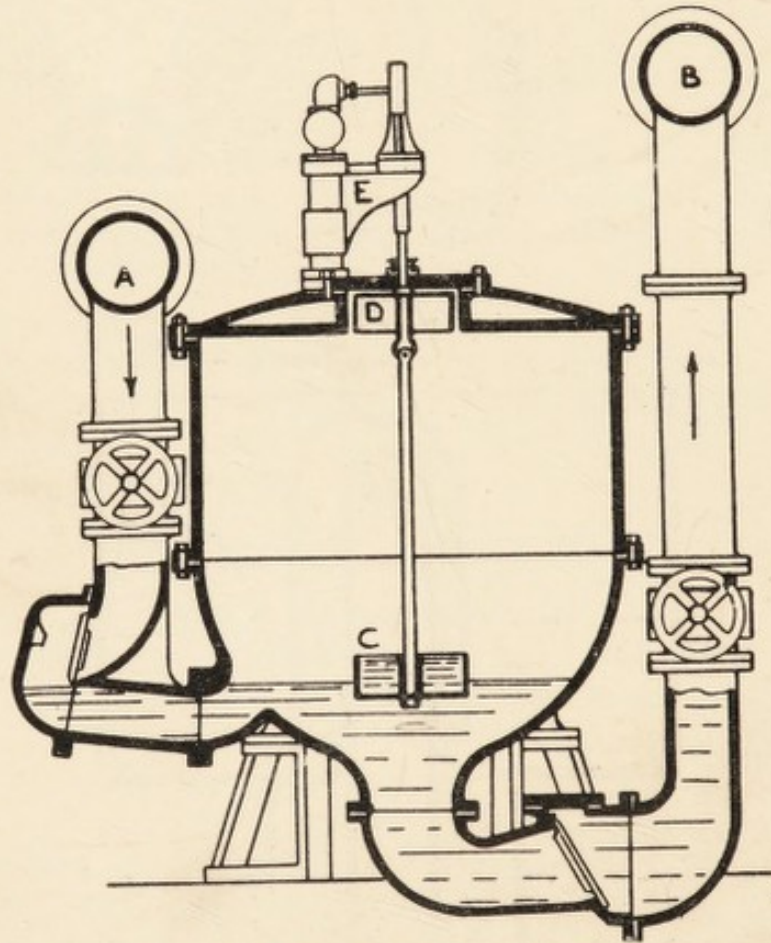

FIG. 50.—Section through a Shone ejector.

the pipe A and gradually rises until it reaches the underside of the bell D. The air inside the bell is then enclosed and the sewage continues to rise until the floating power of the air is sufficient to lift the bell, spindle, etc., which opens the compressed air valve E. The compressed air thus automatically admitted presses on the surface of the sewage, driving it through the opening at the bottom, and through the outlet pipe B. As the air pressure is admitted the valve on the inlet pipe A falls on its seat and prevents the fluid escaping in that direction.

The fluid passes out of the ejector until its level reaches the cup C, and, continuing to lower, leaves the cup full and the weight of the liquid in the cup thus exposed is sufficient to

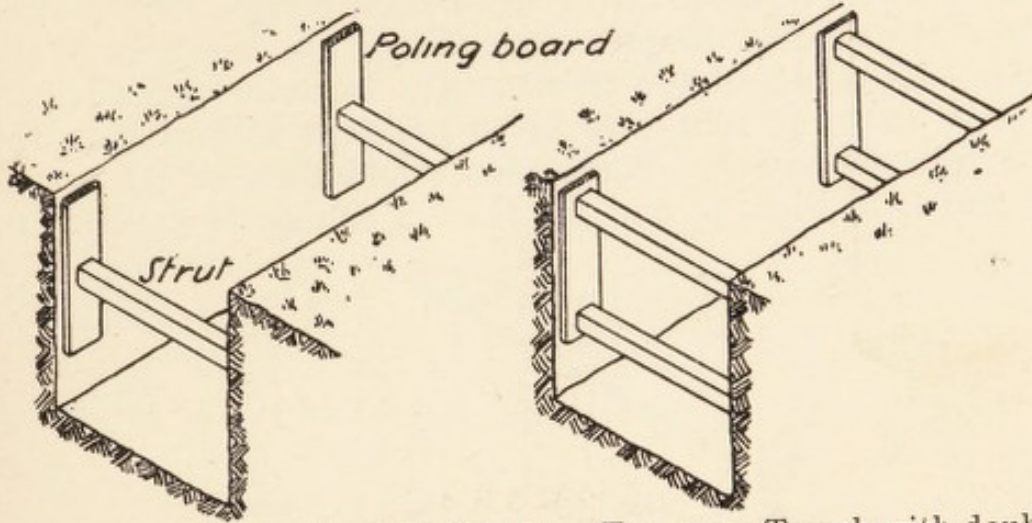

FIG. 51.—Section through trench with single struts and poling boards.

FIG. 52.—Trench with double struts and single poling boards.

pull down the bell and spindle, thereby reversing the compressed air admission valve. The outlet valve then falls on its seat, retaining the liquid in the sewage rising main; the sewage then

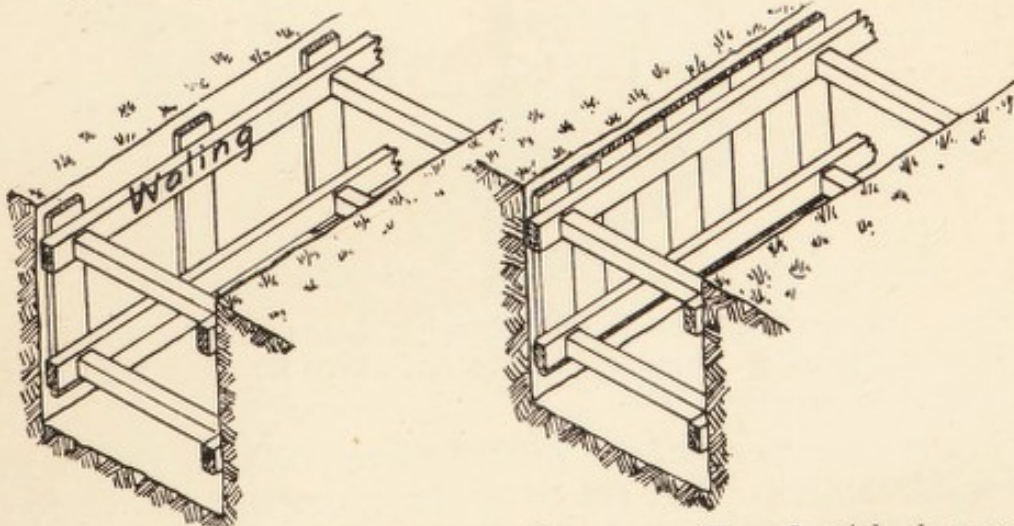

FIG. 53.—Trench with walings, struts, and poling boards.

FIG. 54.—Trench with close poling boards, struts, and walings.

flows into the ejector once more, driving the free air before it through the air valve, and so the action goes on as long as there is sewage to flow. The compressed air for actuating the ejector is produced at some central station, and conveyed in cast- or

wrought-iron pipes laid under the streets to the several ejector stations.

In digging trenches for drain pipes and sewers it is generally necessary to support the sides by timbering. Figs. 51 to 55 show the method adopted according to the looseness of the soil and the depth of the trench. The bottom of the trench will have to be got out to a given gradient according to the size of pipe or sewer. Sight rails would then be set up, as at A and B in Figs. 56 and 57, at each change of gradient or

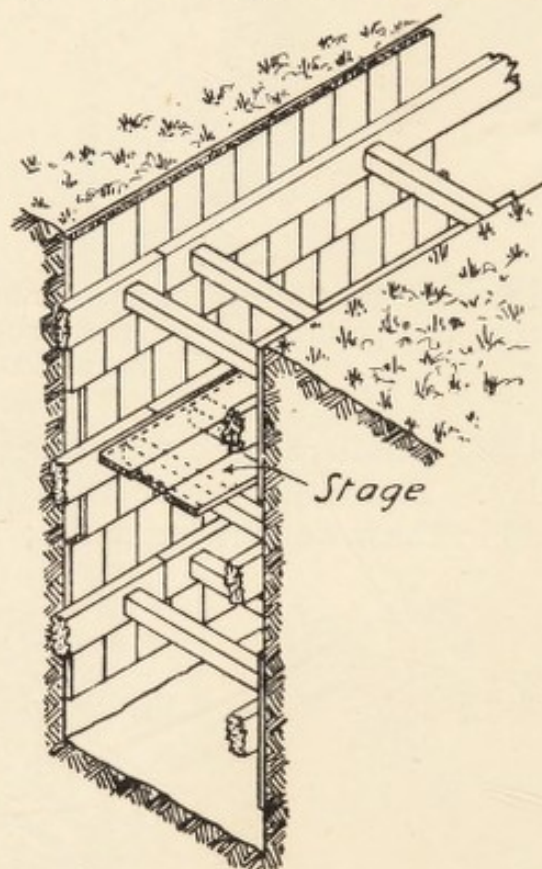

FIG. 55.—Section of deep trench showing close poling boards in tiers, breaking joint, walings, and struts, and stage for receiving materials thrown up in excavating.

deviation of sewer and at intermediate points if the distance is considerable, so that they are not more than 66 to 100 ft. apart. They are so placed that the top edge, where chalked, is a given height above the invert of sewer, say 20 ft. Boning-rods (Fig. 58), as shown, are held in the bottom of the trench at intervals so that the cross piece (*a*) sights level with the sight rails, the foot being raised or lowered as may be required to give the true level of underside of concrete. Generally, pegs are driven in the bottom of the trench to give the levels.

House drains are usually of glazed stoneware socketed pipes, 4 ins. inside diameter. The inside of the socket and outside of the spigot should be left unglazed to allow the cement to adhere fully. They are 2 ft. long exclusive of the socket, that is, measuring from the bottom of the socket to the end of the pipe, and  $\frac{1}{8}$  in. thick. The sockets are 2 ins. deep with  $\frac{3}{8}$  ins. clearance. The completed joint will be as Fig. 59. In water-logged ground special pipes are often used, as Figs. 60 to 63.

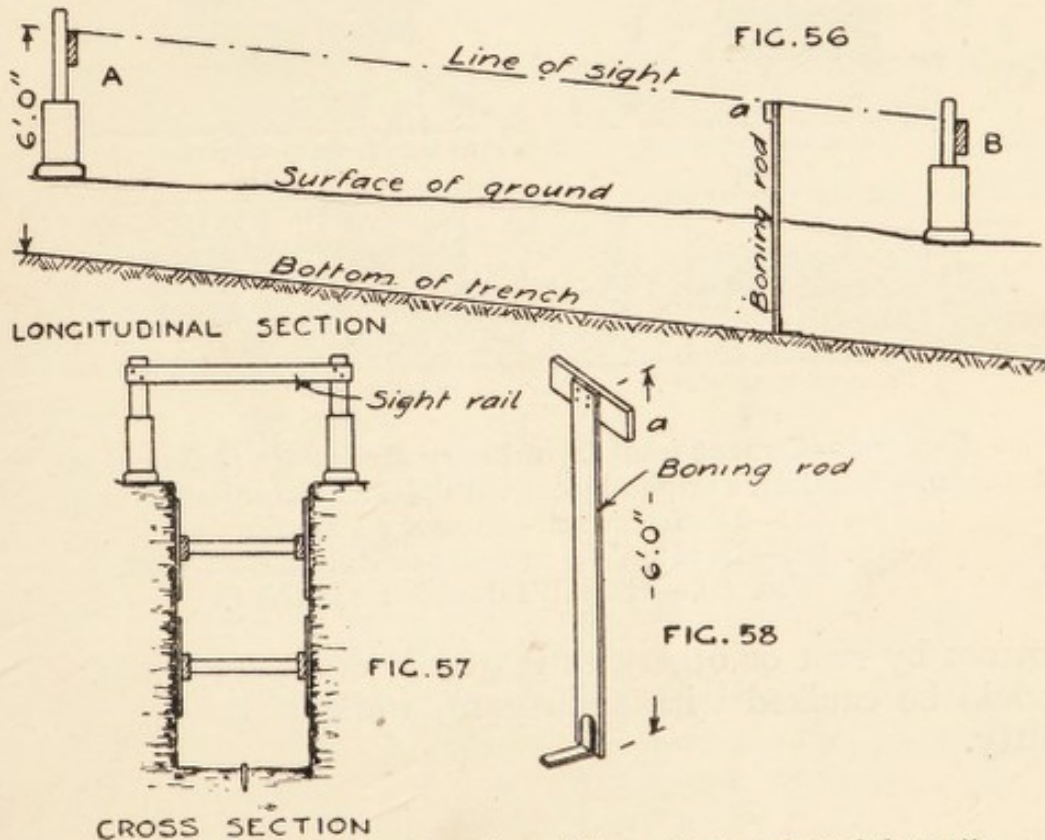

FIG. 56.—Longitudinal section of trench showing sight-rails and boning-rod.

FIG. 57.—Cross-section through trench.

FIG. 58.—Boning-rod.

Cast-iron pipes, the joints run with lead and caulked, are used where the drain passes under or through a building, but stoneware drain pipes may be used if they are encased with 6 ins. of concrete all round. Where any pipes pass through a wall, care should be taken that there is plenty of clearance in the hole, as otherwise any settlement would be likely to cause a fracture of the pipe. In bad ground cast-iron pipes are better than stoneware, as they have fewer joints in a given length, and are stronger.

The joints of cast-iron rain-water down pipes are very often unmade, and consequently if the pipe gets stopped up at the

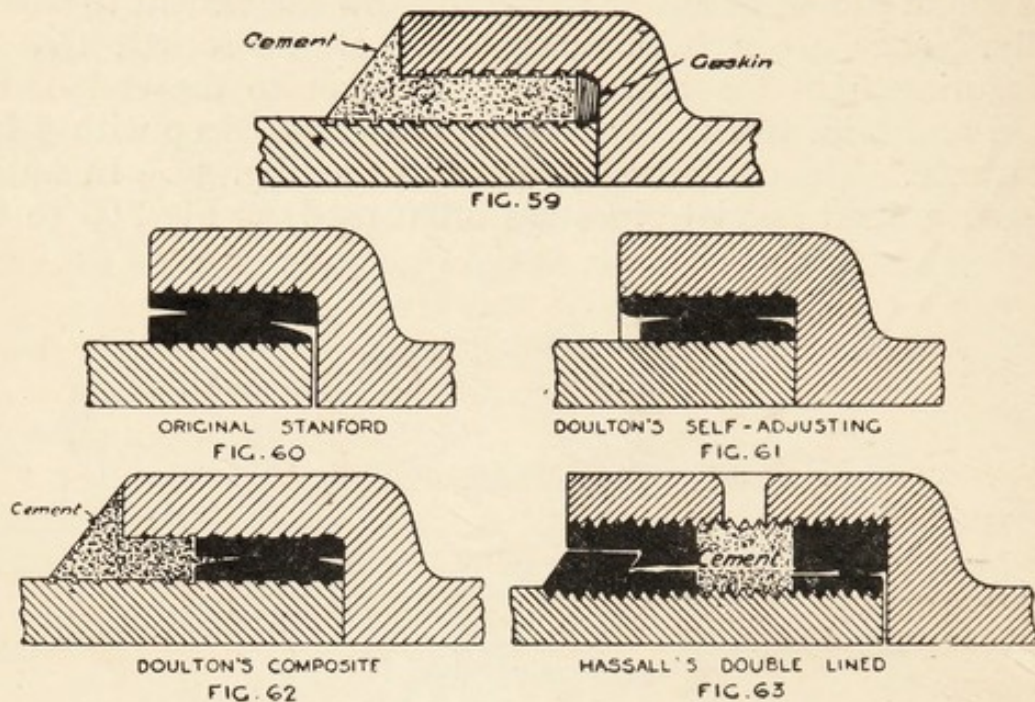

FIG. 59.—Cement joint in ordinary stoneware socket pipes.  
 FIG. 60.—Stanford's original joint with plastic bituminous composition.  
 FIG. 61.—Doulton's self-adjusting bituminous joint.  
 FIG. 62.—Doulton's composite or double-seal joint.  
 FIG. 63.—Hassall's double-lined joint.

bottom by rust or otherwise it overflows at the joints. They should be caulked with spun yarn, worked up with red lead putty.

#### EXAMINATION QUESTIONS RELATING TO CHAPTER XII.

1.—Discuss the respective merits of brick, earthenware, and iron drains. What precautions are desirable when a drain is to be laid at a great depth below the surface of the ground?

2.—A circular sewer, 4 ft. internal diameter, is to be constructed with brickwork in open cutting, the invert being 15 ft. below the surface of the ground. Trial holes show 6 ft. of loose made ground, 4 ft. of clay, and 12 ft. of running sand resting on a thick bed of clay. Show, by sketches, the timbering of the trench and the construction of the sewer, and give a description of the work and materials.

3.—Sketch half full-size sections through the joints of a 3-in. cast-iron rain-water pipe, and a 4-in. cast-iron drain pipe.

4.—A sewer has to be laid through treacherous water-logged ground. Describe what precautions should be taken to ensure soundness of work. Give sketches and detailed information as to how you would execute the work.

5.—What are the principal points to be observed in the laying of a house drain where it passes under the house?

6.—Describe, with sketches, the method of keeping a true gradient by the use of boning-rods.

7.—Describe the various methods of jointing stoneware drain pipes, and state the advantages and disadvantages of each.

8.—Sketch the timbering required for a trench 3 ft. wide and 10 ft. deep in a dry, loamy soil, and add the scantlings.

9.—Describe, in detail, the various steps in constructing a 6-in. stoneware pipe sewer surrounded with concrete, and give a brief specification of the materials employed.

10.—In what circumstances should iron pipes be used for drainage in preference to stoneware? What means are adopted to prevent corrosion in iron pipes? Describe, with sketch, the method of jointing iron pipes.

11.—State of what materials concrete, in which drains are to be laid, should be composed, and their proportions. Describe the methods of measuring and mixing.

12.—What description of drain pipe would you use in the vicinity of a drinking-water well, how would you joint it, and what precautions would you take to avoid settlement?

13.—Explain the terms (*a*) invert level, (*b*) boning-rod, (*c*) sight-rail.

14.—Explain, in detail, how you would set up the "sight-rails" for a new brick sewer, from a working drawing on which the invert levels are given in terms of "ordnance datum."

15.—What do you consider a proper fall for a 6-in. house drain, and how should it be connected with the public sewer?

16.—Explain, with sketches, the use of sight-rails in laying a sewer.

17.—Describe, in detail, the observations that must be made before deciding upon a sea-coast sewage outfall.

18.—Sketch a section showing how drainage should be taken from the rear of a house to the front, the back yard being 6 ins. higher than the street level, the basement 8 ft. below the street level and having an area in front, it being necessary to carry the drain under the house.

19.—A trench 5 ft. 6 ins. wide and 15 ft. deep has to be dug in loose soil. Show the best method of shoring to be adopted, giving dimensions.

20.—Give sketches, with explanatory notes, of some minor means of access frequently provided in connection with drains to supplement or replace manholes.

21.—In reporting upon a sewerage scheme for a district which is already supplied with water, with a population of 10,000, what would you allow for (a) average dry weather flow; (b) the diameter of your main sewer; (c) the area of the outfall works.

22.—In laying down a preliminary scheme for the sewerage of a town, on what basis would you calculate the quantity of sewage to be provided for in the sewers per hour: (a) per head of population; (b) flowing from streets, yards, roofs, and other paved surfaces; (c) from gardens, parks, railways, etc.? What difference would you allow for Manchester, Ambleside, Norwich, and London?

23.—How long would the summer sewage of 3000 persons (amounting, say, to 10 gallons a head a day) take to pass through a 12-in. rising main 2000 yds. long? What objections occur to you as being inseparable from the use of long rising mains for sewage? Upon what depends the question of whether a long rising main is unavoidable?

24.—Give sketch of a combined manhole and storm overflow chamber.

25.—Make dimensioned sketches explanatory of the construction of a manhole, lamphole, and bell-mouth junction for an egg-shaped brick sewer in loose soil 6 ft. deep to invert of sewer.

26.—State the advantages and disadvantages of the combined and the separate systems of sewerage of a town, and what conditions generally determine the adoption of either.

27.—What are the chief considerations in laying out a system of town drainage: (a) for a hilly district; (b) for a flat district?

28.—State some of the modes proposed for the ventilation of sewers and the objections thereto.

29.—When would you prefer to use cast-iron drains? How should the joints be made? What precautions should be taken in passing through a house?

30.—What are the principal points for consideration in designing and laying out a scheme of drainage for a town which is somewhat hilly and for one which is almost flat.

31.—Sketch to scale a bath on the first floor. Show the overflow and service pipes, also the waste continued to the drain. Specify all materials and fittings used.

32.—Describe, and illustrate with a sketch, an apparatus to lift sewage by means of air from a compressor. State under what circumstance you would propose to use such an appliance.

## CHAPTER XIII.

Advantages and disadvantages of various sanitary appliances—Inspection and testing of drainage work and appliances.

THE pan and container water-closet (Fig. 64), with D trap sometimes added, was at one time, say up to 1870, found in every house with a water carriage system, but they have been so frequently condemned that it would be difficult now to find a specimen anywhere. They were flushed direct from the drinking-water cistern, and when the pan was depressed a

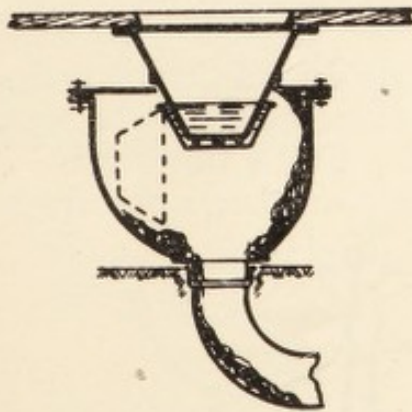

FIG. 64.—Pan and container W.C.

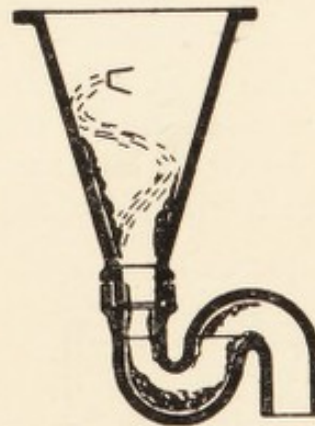

FIG. 65.—Long hopper W.C. basin.

current of sewer gas came straight into the house. The container also was so shaped that solid faecal matter was retained in the angles to further pollute the escaping gases. At the same time the outside, or servants' W.Cs., were of the long hopper shape (Fig. 65), with the flush running spirally down the inside. They were always foul and often the bottom of the trap was broken through by using a poker to clear the basin when the trap got stopped up. The approved modern form to replace these is the wash-down closet (Fig. 66). An intermediate form was the wash-out closet (Fig. 67), which had

several defects for ordinary use. There was not depth of water enough to cover the faeces, the lip of the basin was marked when they were washed over it, the vertical part above the

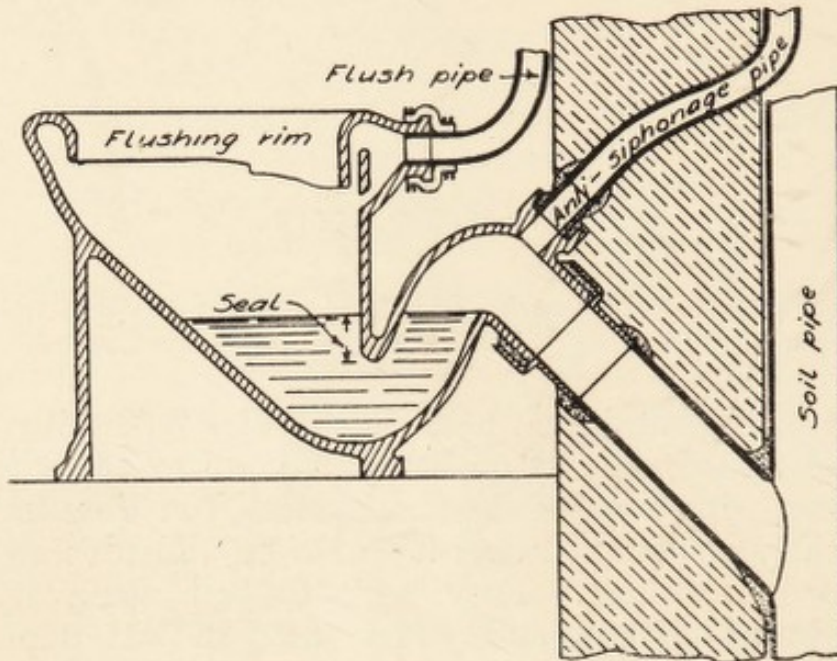

FIG. 66.—Wash-down closet.

trap was fouled and left dirty, giving off foul smells. The wash-out closets found favour in some hospitals because they allowed the faeces to be examined. For a time, valve closets (Fig. 68) were fixed in hotels, clubs, and large private houses,

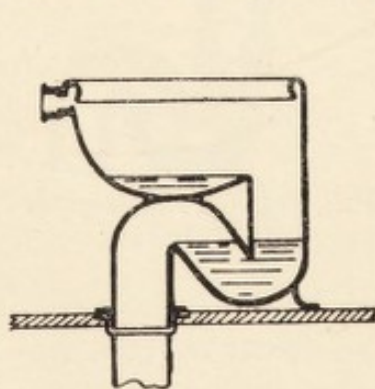

FIG. 67.—Wash-out closet.

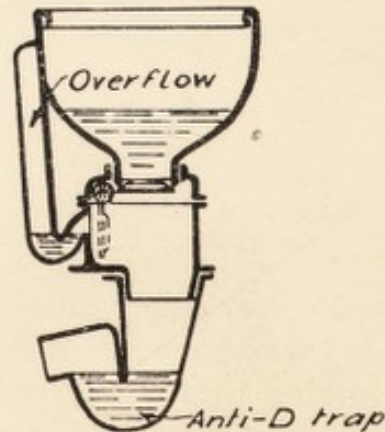

FIG. 68.—Valve closet.

but they were expensive and had other faults, chiefly the valve was prevented from closing by paper which did not wholly pass through. Siphonic closets have also been adopted with no disadvantage except expense.

The water supply to all town-house W.Cs. is now by an independent waste-preventer cistern of which two varieties are shown in Figs. 69 and 70. It is fixed 6 ft. above the seat with a  $1\frac{1}{4}$ -in. flushing pipe having very easy bends. Where a housemaid's slop sink is provided it should be treated exactly the same as a W.C., the only difference being that it has a grating to stop the passage of rings, hair-pins, etc. A housemaid's sink in the ordinary way is a lead-lined tray, often under the hot-water tank, at which water may be drawn off for the bedrooms, and although it has a waste pipe, nothing should be emptied there. The spigot outgo of a W.C. may be luted into a cast-iron socket of the soil pipe with Portland cement, or if the soil pipe is lead, a brass socket may be wiped to the lead

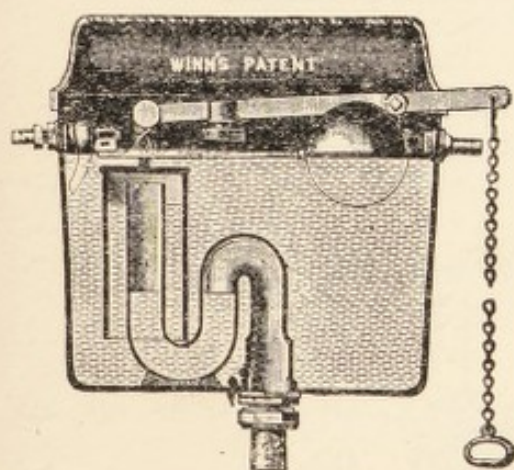

FIG. 69.—Winn's waste-preventer flushing cistern.

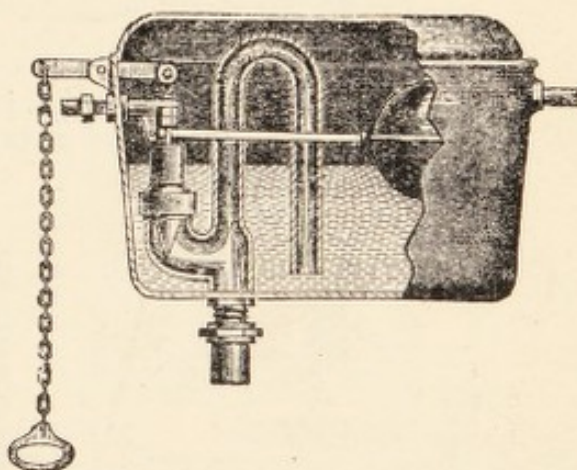

FIG. 70.—Farmiloe's waste-preventer flushing cistern.

for a similar joint. At the lower end of the lead soil pipe, where it joins the stoneware bend of the drain, the joint is made as Fig. 71, and Fig. 72 shows the arrangement if the soil pipe and drain are of cast-iron. The bend shown is known as a "duck-foot" bend, having a bracket with flat surface to take the weight.

In the country, where no water carriage system is available, earth-closets should be used. They are very little trouble, and if properly looked after, are quite sanitary. Fig. 73 shows the general arrangement of Moule's earth-closet, a large removable pail being placed below the seat. When the handle is pulled a measured quantity of earth is thrown on each deposit by the chucker C shown in Fig. 74. A somewhat similar arrangement, but automatically worked, is made by the British

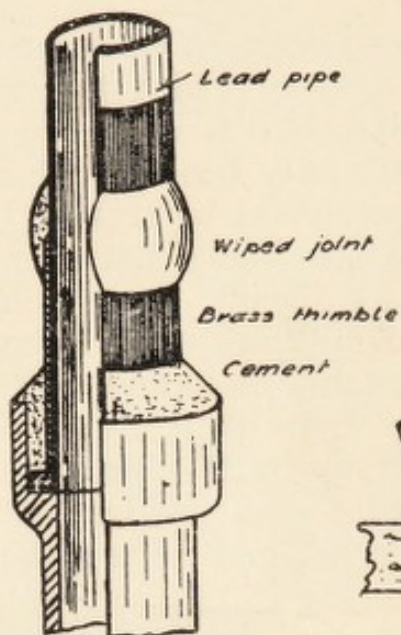

FIG. 71

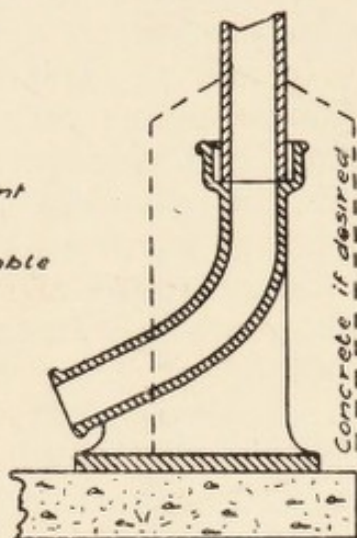

FIG. 72

FIG. 71.—Lead soil pipe joining stoneware pipe.  
 FIG. 72.—Duck-foot bend at bottom of cast-iron soil pipe.

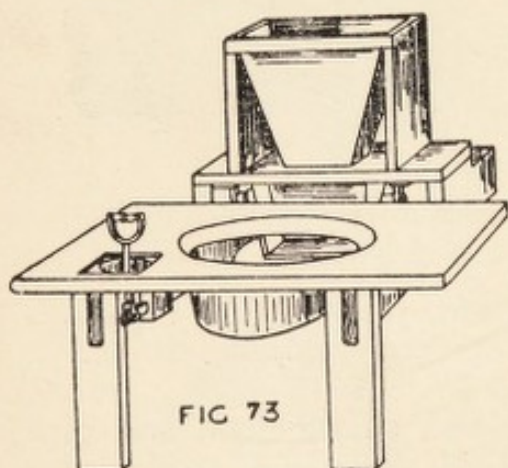

FIG 73

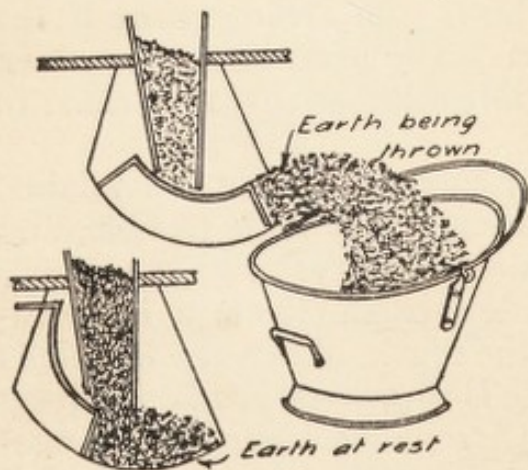

FIG. 74



FIG. 75

FIG. 73.—Moule's earth-closet with pail removed.  
 FIG. 74.—Action of chucker for earth-closet.  
 FIG. 75.—Earth-closet made by the British Sanitary Co.

Sanitary Co. (Fig. 75), in which the seat is depressed one inch when used and this, in rising again, throws the earth on the surface of the contents of the pail. The contents of the pail may be dug into a garden or emptied into a shed with open sides. No smell is caused and the earth can be used over again after a time. Earth is a natural deodorant and disinfectant, but ashes or sand are of no use.

If there is a partial water carriage system a cesspool may be used to receive the foul water, constructed as in Fig. 76. This should be at least 50 ft. away from any dwelling, and not

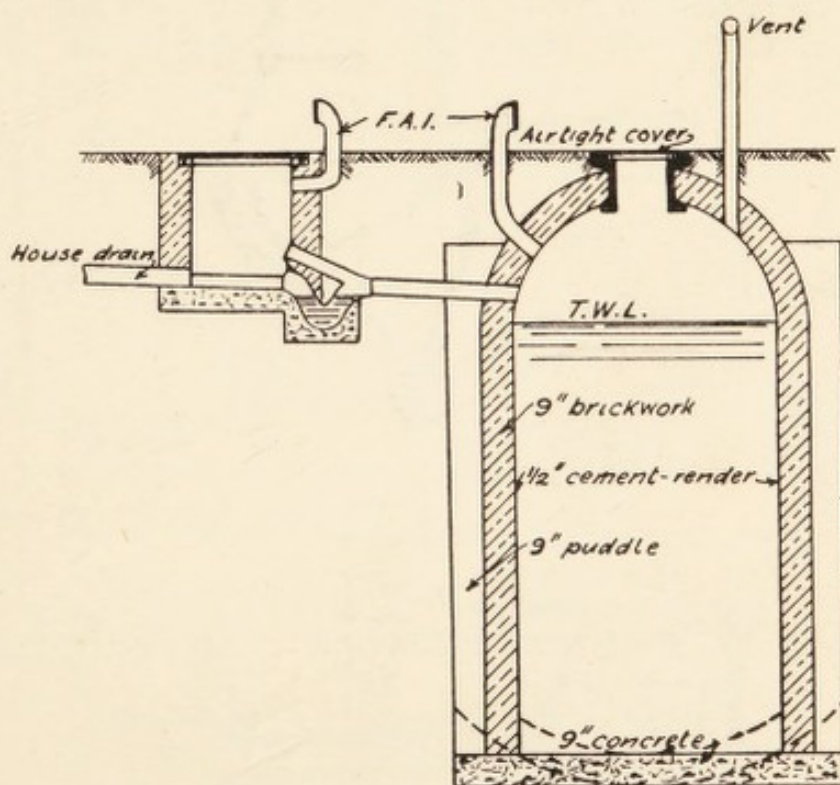

FIG. 76.—Cesspool and disconnecting chamber.

near a well. It may be arranged with a pump so that the liquid may be used on the garden.

Where water is scarce, as in many villages, Day's Stafford waste water-closet, as shown in Fig. 77, or Duckett's slop water-closet, as Fig. 78, may be used. They are, of course, not to be compared with, say, the modern wash-down W.C. for cleanliness and efficiency, but there may be places where they are useful.

The inspection of new drains should commence before the excavation is filled in, the points to look for would be that the pipes are sound and of good quality, laid in straight lines and

with regular falls, the joints sound and well flushed up with cement, especially on the undersides, the sockets laid "up stream" and the pipes resting on their body. Where the pipes pass through walls an arch should be turned over the opening, or at least the bricks gathered over to roof the opening without pressure on the pipes. The lower end of the drain, in

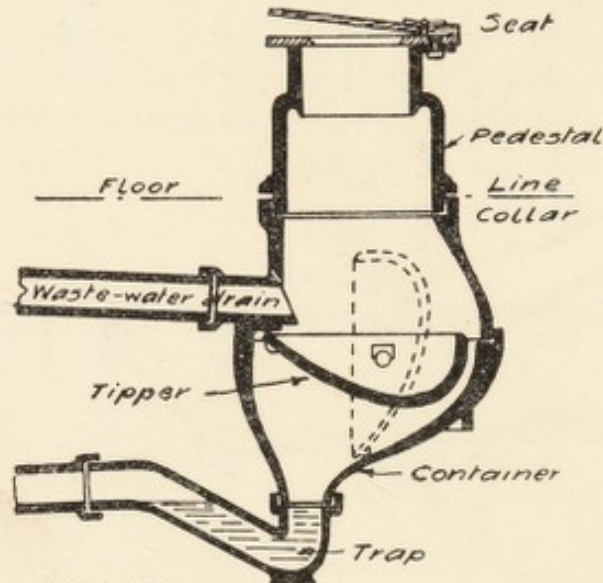

FIG. 77

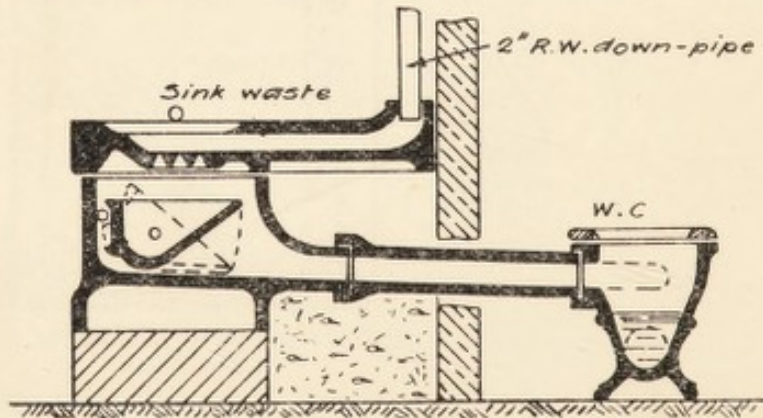

FIG. 78

FIG. 77.—Day's Stafford waste water-closet.

FIG. 78.—Duckett's slop water-closet.

the intercepting chamber, should be plugged with a drain stopper before testing, and water filled in from the highest gully. It is necessary to remove the air from the higher part of the drain by passing an india-rubber tube through the seal of the gully. A further head of 2 ft. is desirable which may be obtained by inverting a drain pipe over the gully and bedding it in puddled clay to prevent leakage. This pipe being filled

up, the whole should be left for an hour. If the level of the water falls appreciably there is a leak and close search must be made for it so that it may be remedied. The quantity of water to fill a drain may be calculated thus,  $d$  = diameter in inches,  $L$  = length in yards,  $G$  = gallons, then  $G = \frac{d^2 L}{10}$ .

The water test is considered too severe for old drains, but it is quite as necessary that they should be tight under such a small head of water as 2 ft. Old drains are usually tested by the smoke test. All gully traps being plugged with a lump of clay a smoke rocket or the nozzle of a smoke machine is inserted in the lower end of the drain and set going. The top of the soil pipe ventilator is similarly plugged or covered with a wet cloth as soon as the first sign of smoke is visible

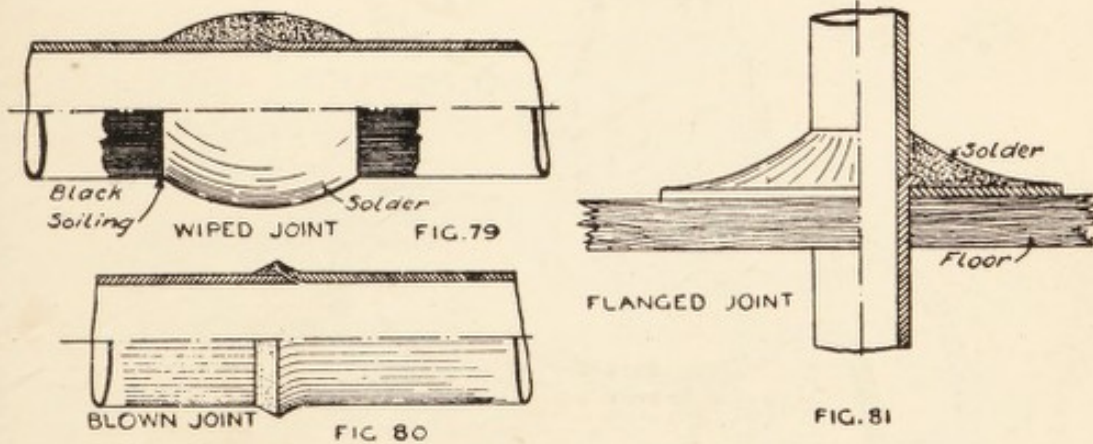

FIG. 79.—Wiped joint in lead pipes.

FIG. 80.—Plumber's copper-bit joint.

FIG. 81.—Flange joint in lead pipe at floor level.

there ; then the course of the drain is watched and the interior of the house inspected to see that there is no smoke showing anywhere. Peppermint and other smell tests are not very reliable and are often perfunctorily made.

The internal plumbing should be very carefully examined, it would take a volume to describe everything the inspector should look for, and, after all, a book is no substitute for practical experience. The joints in lead pipes should be wiped joints, as Fig. 79, not blown, or copper-bit, joints, as Fig. 80. When passing through a floor the weight of the pipe may be held up by a flange joint, as Fig. 81. Screw-down bib-cocks should be used, as in Fig. 82. Their advantage is that they

cannot be closed suddenly so as to cause a shock in the pipes by the arrested momentum of the water, which is called "water-hammer." When leaking they are repaired, after shutting off the water, by putting on a new washer at the bottom of the spindle. The washer is usually of a dense fibre, but may be of india-rubber, or of leather, except in the case of a hot-water tap. The end of the union is tinned over so that the lead supply pipe can be readily connected by a wiped joint. With

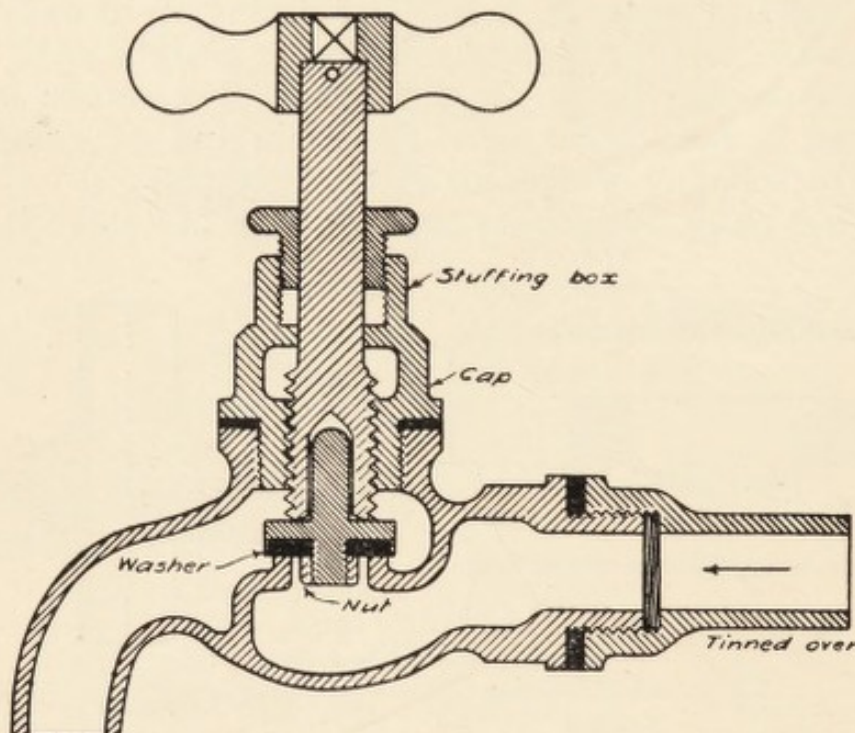

FIG. 82.—Screw-down bib-cock with union.

iron pipes the end of the bib-cock is screwed direct into the iron ferule.

The weight of lead supply pipes, subject to water pressure from the mains, may be taken as—

Up to 110 ft. head,	bore in $\frac{1}{8}$ ths of an in.	$\times 1\frac{1}{2}$	= lb. per. yd.
Between 110 and 150 ft. head,	" " " "	$\times 2$	= "
Above 250	" " " "	$\times 3$	= "

The weight of lead distributing pipes in house should be bore in  $\frac{1}{8}$  in.  $\times 1\frac{1}{2}$  = lb. per yd. Flushing and warning pipes, bore in  $\frac{1}{8}$  in. — 1 = lb. per yard.

## EXAMINATION QUESTIONS RELATING TO CHAPTER XIII.

- 1.—Make a sketch of a W.C. pedestal, show the various joints and describe how they are made.
- 2.—The 4-in. house drains of a detached villa run for 100 yds. before reaching the sewer, and have a fall of 1 in 75; what provision would you recommend for keeping them clear of deposit?
- 3.—Describe, and illustrate by sketches, various methods of flushing closets by slop water. Why is this mode of flushing better adapted for villages than for large towns?
- 4.—Describe a "pan-closet." State what are its defects, if any, and how those defects are overcome in modern apparatus. Give sketches of "valve," "wash-out," and "wash-down" apparatus.
- 5.—Sketch and describe what you consider the best type of each of the following: (a) water-closet; (b) yard gully; (c) disconnecting trap.
- 6.—Describe (with sketches) the best forms of closets for dwelling-houses, and also the best sanitary arrangements for factories where people of both sexes are employed.
- 7.—Give sketch of a square acre of land with measurement of sides; show main subsoil drain running through to south-west corner with suitable branch drains. Give sizes and depths of drains.
- 8.—Give the dimensions and sketch of the lead tacks for a soil pipe, describe how they are fixed, and state their distance apart.
- 9.—Describe the following and explain for what purpose each is used: (a) Buchan's trap; (b) swan-necks; (c) raking-arm; (d) flashing; (e) wiped joint.
- 10.—If the bottom of a soil pipe becomes blocked what will be the effect of its filling with liquid? What is an air lock in a pipe?
- 11.—Do you know of any advantage in fixing external soil pipes either on the north, east, south, or west elevation of a building. If so, what is it?
- 12.—Describe, and give sketches of, the following joints in plumber's work: wiped joint, flanged joint, copper-bit joint.
- 13.—How can rain-water pipes become a source of air pollution in houses? How should rain-water pipes discharge into house drains?
- 14.—Describe how the following appliances, although of good design, sometimes become a source of danger to health through bad plumbing work: (a) valve-closet; (b) slop sink; (c) bath; (d) lavatory; and (e) scullery sink.
- 15.—Explain, and give sketches of, three methods of connecting the outlet of a stoneware W.C. basin with a lead soil pipe.

16.—Make sketches explanatory of the following: (1) connection between soil pipe and house drain; (2) inspection chamber with fresh-air inlet; (3) anti-siphonage pipe.

17.—How is "siphoning" produced in the trap of a W.C., and how is it avoided?

18.—Explain the various methods of connecting the lead flushing pipe with the stoneware W.C. pan.

19.—Describe, with sketches, how the junctions are made (*a*) between a W.C. and the soil pipe; (*b*) between the soil pipe and the drain; (*c*) between the drain and the sewer.

20.—What nuisances are liable to arise from the use of open hopper heads for receiving sink and bath waste water? What steps can be taken to obviate nuisance?

21.—Sketch and describe the proper methods for making the following joints: plumber's wiped joint, lead to iron pipe, stoneware to iron pipe.

22.—Show, by sketches, the method of jointing a 4-in. lead soil pipe, its attachment to a wall, and its junction with a stoneware house drain.

23.—How should a scullery sink waste be led to the drain? State briefly the reason for each precaution you mention.

24.—Mention the various kinds of joints made in connecting lengths of lead soil pipe. State which variety you prefer, with the reasons for your selection.

25.—What is an anti-siphon pipe, and why is it used? Illustrate your answer by a sketch.

26.—Describe, in detail, and make a sketch of the best form of closet for a rural district, where there is no system of sewers.

27.—Explain the construction and working of an earth-closet, and name a suitable position for it.

28.—State the advantages and disadvantages in the use of the following sanitary appliances: slop sink, grease trap, siphon interceptor, bell trap, long hopper pan, siphonic discharge pan, lead S trap.

29.—A 9-in. glazed stoneware socket pipe receives the sewage of a block of houses, and is found to be defective. State briefly what procedure you would adopt to remedy the defects.

30.—What are the respective advantages and disadvantages of a glazed stoneware scullery sink, a York stone sink, and a lead-lined wooden sink?

31.—Write a specification for the supply and fitting of a scullery sink complete in a town house.

32.—Sketch to a large scale: bath trap and waste, slop sink with

trap, section of a 50-gallon automatic flushing tank, and mark the dimensions on each.

33.—Explain the action of the siphon. Illustrate, by sketches, its application to various sanitary appliances.

34.—What quantity of water is usually stipulated by water companies for one flush of W.C. Do you consider it sufficient, and how would you arrange so that it may be utilized to the best advantage?

35.—Draw sections through two good forms of W.W. preventers (or flushing cisterns) showing their construction, and explain the principles upon which each works.

36.—Sketch and describe the action of an automatic flushing cistern suitable for use in conjunction with a range of public urinals of six stalls.

37.—What defects are commonly met with in (a) water-closets and their connections; (b) soil pipes; (c) bath, sink, and lavatory wastes?

38.—When inspecting houses, to what points would you direct your attention to ascertain whether the drainage is in a proper condition?

39.—Name the various tests to which a drainage system may be subjected. State, also, any special circumstances in which each of the tests is applied, and describe fully the method of applying the smoke test to the drainage system of a dwelling-house.

40.—Show by a rough sketch how you would drain a semi-detached villa, showing a water-closet and sink on the ground floor and a water-closet on the first floor.

41.—Sketch the section of a good earth-closet, and describe the manner in which the earth is applied to the excreta, and state what precautions must be adopted to ensure the satisfactory working of the closet.

## CHAPTER XIV.

The various systems of dealing with sewage and house refuse—Disinfecting apparatus and disinfectants.

THE sewage of sea-coast towns is often discharged direct into the sea, at certain states of the tide, with more or less objectionable results.\* In London the sewage is treated with lime to cause settlement of the solids, the sludge is removed in tank ships and sunk at Barrow Deep near the mouth of the Thames, and the liquid is discharged into the river. In some parts of the country the sewage is spread on the land without previous treatment, the system being known as broad irrigation. If the soil is stiff clay 1 acre will be required for every 25 population, if a loamy clay, 1 acre per 100 population. The Rivers Pollution Commission recommend 1 acre per 150 population, without specifying the soil. If simple precipitation is effected beforehand, then on clay 1 acre per 200, on loamy ground 1 acre per 400, and on sandy gravel 1 acre per 500 or 600. With approved chemical precipitation, or septic or bacterial tanks, 1 acre per 2000 population. As a general system, the disposal on land is not approved; the sewage ought to undergo proper bacterial treatment so that an innocuous effluent can be discharged into the nearest stream. Fig. 83 shows how the land is prepared for broad irrigation, and Fig. 84 the preparation for the method of filtration. It should be noted that the horizontal scale is contracted compared with the vertical measurements.

The ordinary method of sewage purification and disposal is by what is called septic tank treatment. The first requirement is a screen chamber at the outfall of the main drain or sewer, with sludge pit and drain. This is followed by grit or

\* See "The Sewerage of Sea-Coast Towns," by H. C. Adams. London: Crosby Lockwood & Sons, 6s. net.

detritus tanks in duplicate, each with a capacity of about  $\frac{1}{100}$  daily dry weather flow (D.W.F.) with an overflow weir to carry off storm water when it exceeds three times the D.W.F.; sludge pit and pipe. Alongside these are storm-water tanks, generally in duplicate, each with a capacity of  $\frac{1}{8}$  D.W.F., arranged for continuous flow and self-emptying into a stream when no storm water is passing through. The septic tank proper is also in duplicate, each to hold  $\frac{1}{2}$  D.W.F. The inlet and outlet weirs at the same level baffle walls and scum boards, causing the flow to traverse all parts without agitation. Sludge pit and sluice valve at bottom of each tank. No cover is required, as the scum forms a hard crust on top of the sewage.

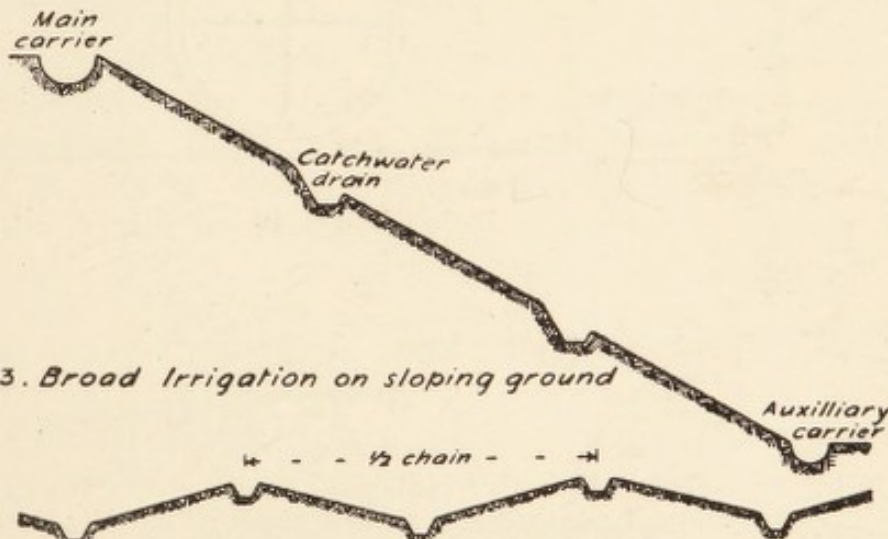

Fig. 83. Broad Irrigation on sloping ground

Fig. 84. Broad Irrigation or Filtration by ridges and furrows on level ground

FIG. 83.—Land prepared for broad irrigation.

FIG. 84.—Broad irrigation or filtration.

The septic tanks are followed by dosing tanks where a certain quantity of the sewage can be collected and automatically discharged at intervals on to the filters. Percolating filters 3 to 6 ft. deep, and of sufficient area, are generally supplied by sprinklers, which traverse the whole surface. The liquid drained off from the bottom passes through a humus tank,  $\frac{1}{12}$  D.W.F., and is then discharged into a stream or on to the land. A common arrangement is shown in Fig. 85, with section (Fig. 86). Fig. 87 shows the arrangement that may be adopted for a small institution or hotel, or large private house in the country.

In designing sewage disposal works for a population of 500

much depends upon whether such works are for a large institution or a small village. The most important factor is that in the case of a village the purification works must be completely

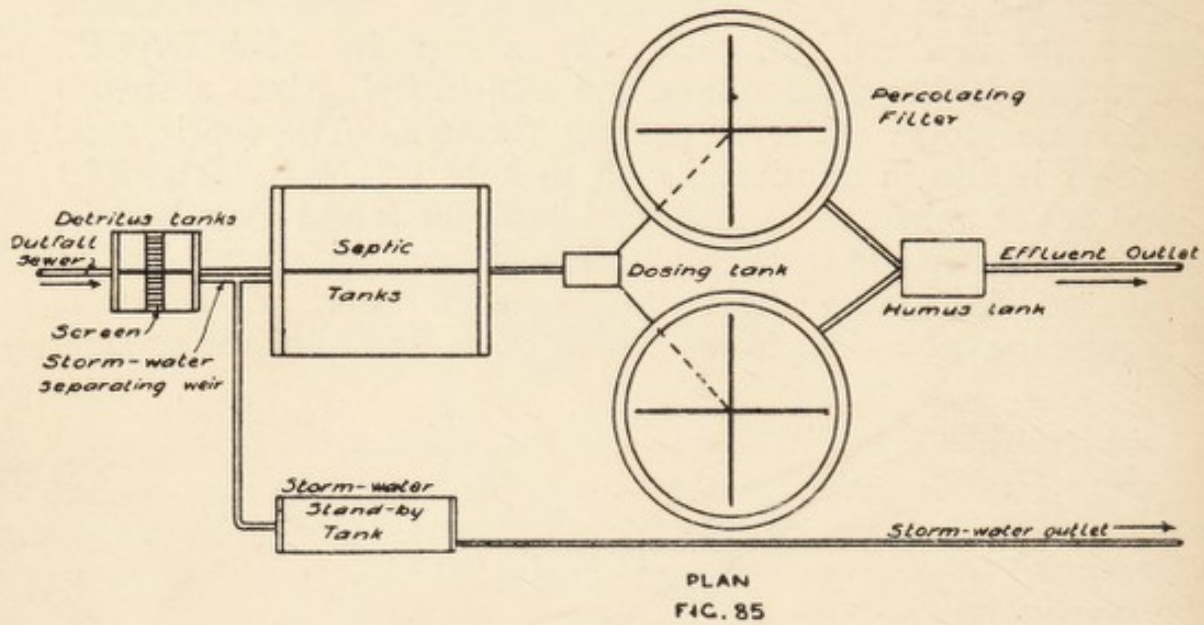

FIG. 86

LONGITUDINAL SECTION

FIG. 85.—General plan of biological treatment of sewage.  
FIG. 86.—Longitudinal section through same.

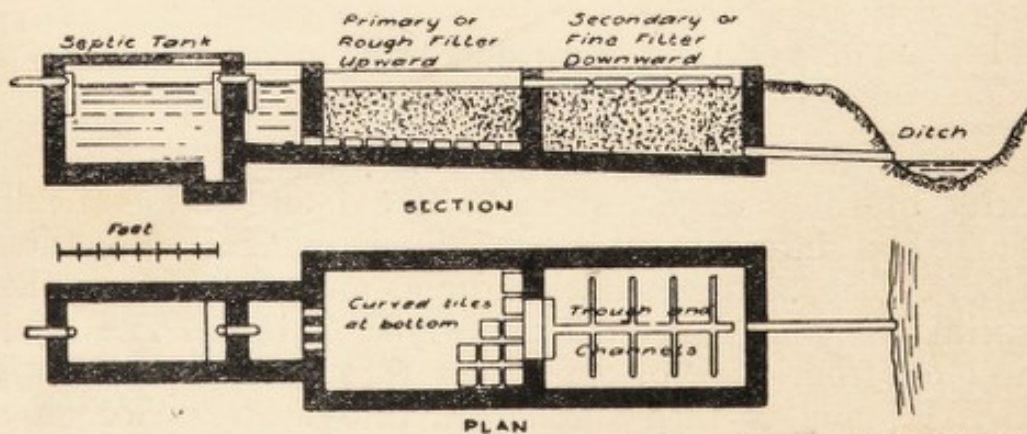

FIG. 87.—Arrangement of septic tank and filters for small institution.

“fool-proof,” and such that they will remain effective without supervision, a condition almost impossible of achievement. In a small rural district the works are almost certain to be neglected

owing to the small amount of money available, and frequently the officials of the Authority are paid less salary than would be required by an attendant competent to manage the sewage works. At the best, an intelligent labourer would be engaged, hence there must be nothing in the maintenance and management of the work that requires skill and experience. In an institution the services of a qualified man could generally be obtained, and, as power is generally available, there is scope in the design of details, and even in the method of purification to be adopted. The quantity of sewage would vary. In a village the amount would average about 15 gallons per head per day, while in an institution the amount might average 40 gallons per head per day, owing to the large quantities of water used for cleaning and laundry purposes. It consequently follows that village sewage would be much stronger than institution sewage, and tanks and filters should be designed on a more liberal basis. The fluctuations in flow from an institution would be much greater than from a village, and some means should be adopted of regulating or equalizing it.

A sewage effluent must not contain more than three parts of suspended matter per 100,000 of liquid, and must be free from smell.

The activated sludge process may be briefly described as follows: Activated sludge is sewage that has had air blown through it from two to six hours. It is a dark-brown flocculent deposit with an earthy and inoffensive odour, settling very rapidly and containing 97-98 per cent. water. It drains fairly easy down to 90 per cent. water, but not further owing to its gelatinous consistency. It is used in sewage purification by thoroughly aerating a mixture of one volume of activated sludge with three to five volumes of fresh sewage in a tank. The operation is then stopped, the clotted mixture allowed to settle, the clarified effluent drawn off and replaced by a fresh volume of sewage. A typical activated sludge plant is shown in Figs. 88 and 89.

The Committee on Sewerage and Sewage Disposal to the American Public Health Association have published the following definition: "Activated-sludge process is the agitation of a mixture of sewage with about 15 per cent. or more of its volume of biologically active liquid sludge in the presence of ample atmospheric oxygen, for a sufficient period of time at least to coagulate a large proportion of the colloidal substances,

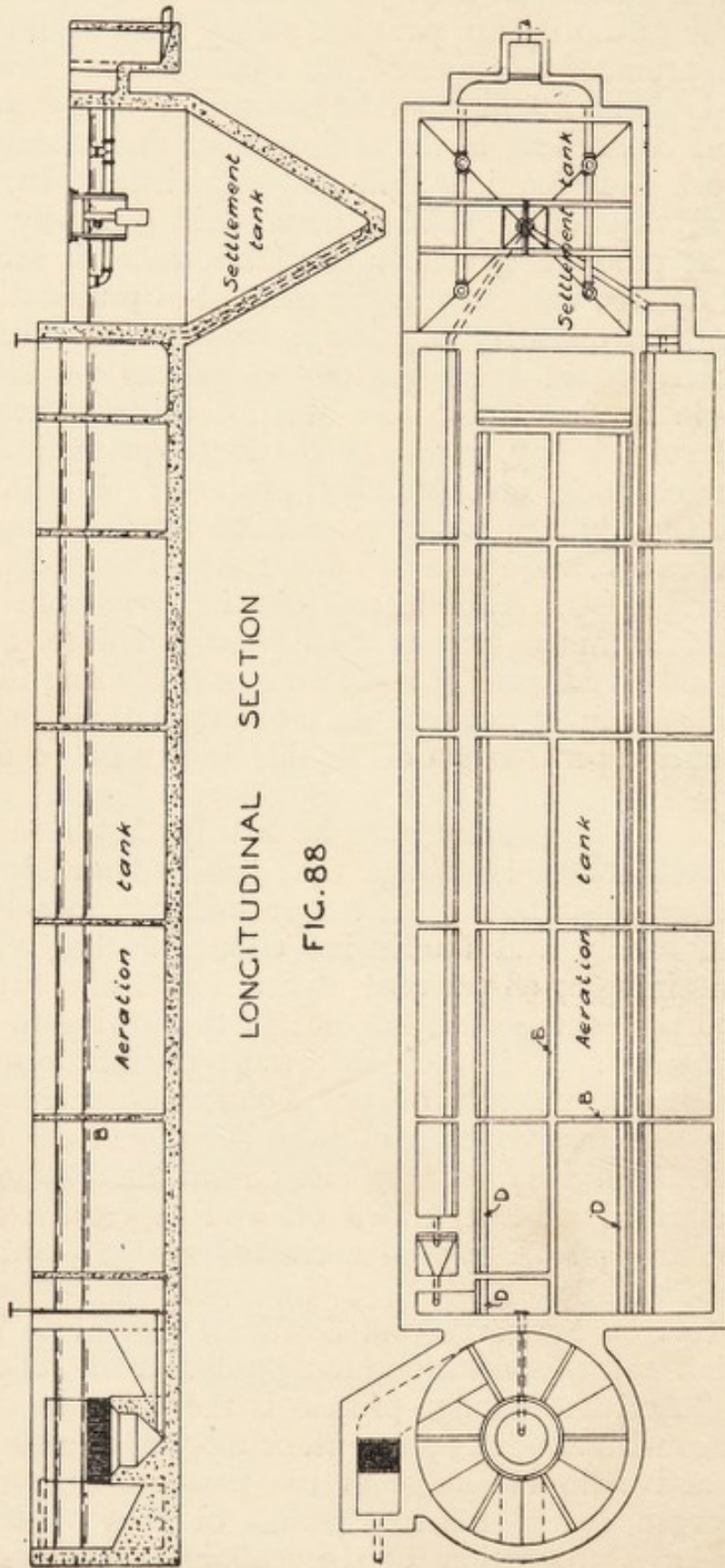

PLAN OF TYPICAL ACTIVATED SLUDGE PLANT  
 FIG. 89

FIG. 88.—Section through activated sludge plant.  
 FIG. 89.—Plan of same.

followed by sedimentation adequate for the subsidence of the sludge flocculi; the activated sludge having been previously produced by aeration of successive portions of sewage and maintained in its active condition by adequate aeration by itself or in contact with sewage."

In sewage filter beds the prepared sewage passes over them continuously; in contact beds the action is intermittent, at least three contact beds being necessary, contact being allowed for two hours and the effluent then run off while the sewage is diverted to the other bed. The first one remains empty and open to aeration during the next two hours, when the operation is repeated. The beds are generally made up of clinker or hard coke, but Dibden's slate contact beds have layers of slate with 1 in. space between. The object is to give a large surface area for the contact of the sewage with the purifying bacteria.

"House refuse" under the Public Health (London) Act, 1891, includes ashes, cinders, breeze, rubbish, night soil, and filth, but does not include "trade refuse," which is the refuse of any trade, manufacture, or business; or building material. The quantity of house refuse varies from 14 to 23 cwts. per day per 1000 population according to the district, being higher where fuel is cheap. London collects 5.2 cwt. per head per annum. The storage should be in standard galvanized dustbins 18 ins. diameter and 24 ins. high, holding  $3\frac{1}{2}$  cub. ft. with loose outside-fitting lid, to prevent the access of flies, and emptied weekly. Where a daily collection is made the receptacles may be smaller. The contents are transferred to horse- or motor-driven vehicles and are usually taken to a destructor; tipping on vacant land can only be resorted to in special cases, and should always be avoided if possible. The weight of house refuse varies from 28 lb. to 45 lb. per cubic foot, say 30 lb. per cubic foot average. In modern destructor depots salvage operations are first undertaken to remove any useful or objectionable substances from the refuse. A Meldrum destructor with, say, 10 ton cells, each 6 ft. by 4 ft., burns 40 lb. per hour per square foot of fire grate working for 24 hours per day. The temperature varies from 1250° F. to 2000° F. Where no salvage has taken place the clinker averages 30 per cent., of which 2 per cent. is old iron. A 10-ton cell will consume the refuse for a population of 10,000. Large installations are built in units of four cells.

Fig. 90 shows Horsfall's destructor, the construction of

which is evident from the section given. A steam jet forces air into the closed ash-pit at a pressure of  $\frac{3}{4}$  to 1 in. of water, producing a temperature of 1500° F. to 2000° F. The whole destructor may consist of several cells which each deal with 8 to 10 tons per 24 hours.

Another method is to put the refuse through a mechanical destructor, such as the Jeffrey pulveriser, which converts it into a deodorised, inoffensive black mould used by farmers as a fertiliser. Revolving hammers travelling at high speed break the refuse up into a fine mass, mixing it thoroughly and finally passing it through grids in the base.

Smoke observations under the P.H.A. (1875), and the

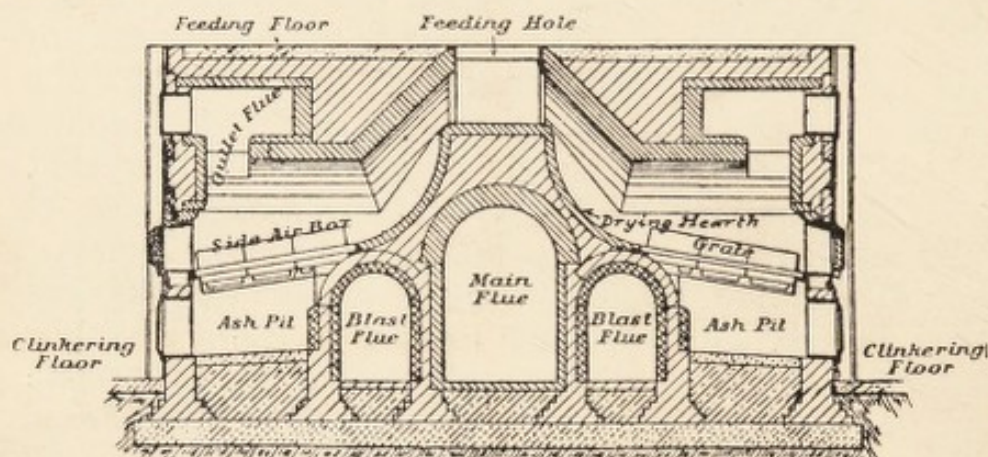

FIG. 90.—Section of Horsfall's destructor furnaces.

P.H.(L.)A. (1891), should be noted for one hour. The maximum time limits for black smoke are:—

1 boiler	.	.	.	.	2 minutes allowed.
2 boilers	.	.	.	.	3 " "
3 "	.	.	.	.	4 " "
4 "	(or more)	.	.	.	6 " "

A suitable smoke scale is the following:—

- No. 0 = No smoke.
- " 1 = Light grey smoke.
- " 2 = Darker grey smoke.
- " 3 = Very dark grey smoke.
- " 4 = Black smoke.
- " 5 = Very black smoke.

Disinfection is of two kinds, that carried on by special apparatus in a permanent building, and that effected in any

house or place where an infectious disease has occurred. The simplest possible general arrangement of a disinfecting station is shown in Fig. 91, where the various parts are named. The entrance to each is by an external door. The essential points in a disinfecting station are that the receiving room for the infected materials and the delivery room for the disinfected goods must have no direct communication with each other except through the disinfector; a solid wall must intervene, but it may have a fixed window to enable the attendants to see and signal to each other. There should be a lavatory in the infected chamber for washing the hands and face, and other facilities in a large station. Nothing must pass from the infected side to the other without going through the disinfector.

The disinfector itself is an iron chamber or vessel, cylindrical or oval, with a door at each end. It is surrounded by a steam jacket, i.e. steam is contained in the space between an inner and outer shell. This enables the contents to be dried after the inside steam has done its work and been shut off. The interior has a strong wire cage, or carriage, to contain the articles to be disinfected, and runs on wheels upon rails laid in the bottom.

In using the disinfector the contained air should first be expelled by blowing steam through for a little while. Steam penetrates the articles better than air, and saturated steam is better than superheated. Saturated steam is that form which exists in contact with the water from which it was generated. Superheated steam is steam that is further heated after passing away from the boiler, so that it is more in the condition of a gas than a vapour. For disinfection saturated steam is used at a temperature of 239° F. and 10 lb. per sq. in. gauge pressure.

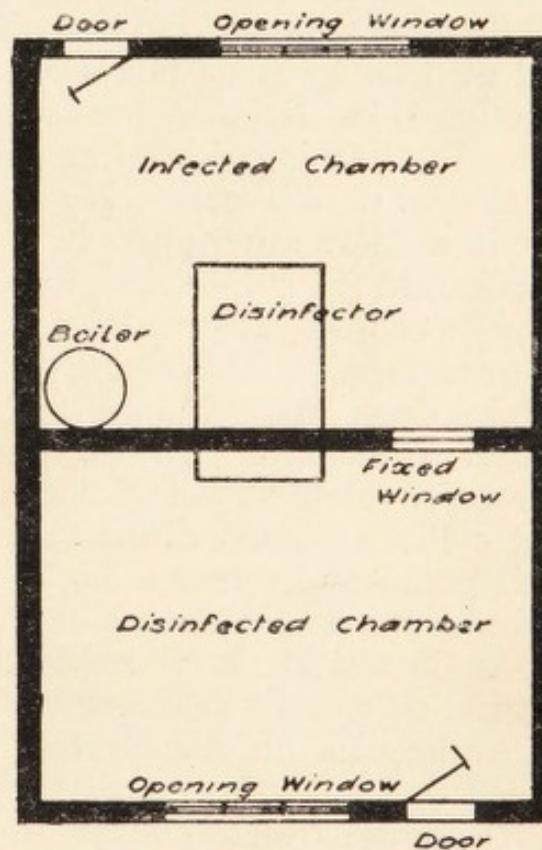

FIG. 91.—General arrangement of disinfecting station.

A disinfectant is a substance that kills infection, otherwise a germicide or bactericide. Perchloride of mercury (corrosive sublimate) is the strongest, and is generally used in the proportion of 1 part in 1000 parts of water, or, more accurately, 1 part in 1000 for non-sporing bacteria, 1 in 500 for sporing bacteria. It is extremely poisonous, and is only used in special cases, as for disinfecting the fæces of a typhoid patient. Carbolic acid is much to be preferred for general use, in a 5 per cent. solution; or for washing the hands, in a  $2\frac{1}{2}$  per cent. solution. For disinfecting a room formalin is used. It is obtained as a 40 per cent. solution of formic aldehyde ( $\text{CH}_2\text{O}$ ), and used for spraying in a 2 per cent. solution (1 oz. to 1 pint), 1 gallon being required for every 600 sq. ft. Or in a gaseous form by burning paraform tablets in an alformant lamp, 20 tablets or 100 grams per 1000 cub. ft.; it is most effective in a damp atmosphere in a sealed room. Another gaseous disinfectant is sulphurous acid ( $\text{SO}_2$ ), obtained by burning sulphur candles, 1 lb. sulphur to 1000 cub. ft., but it has the disadvantage of bleaching colours. Gaseous disinfectants require doors and windows to be pasted up and the chimney flue to be blocked. Disinfection by sulphur may now be considered obsolete as being slow and uncertain in action. Izal and cyllin are good disinfectants as their toxicity is low and their germicidal power is high. Disinfectant powders may be looked upon as deodorants only.

An insecticide is a substance that will kill small insects, but not necessarily germs or bacteria.

Antiseptics do not destroy micro-organisms, but simply retard their growth.

Deodorants merely mask an unpleasant smell or remove it without removing the cause, such as the washing of tainted meat with a weak solution of permanganate of potash.

*Incubation Period of Infectious Diseases.*

Measles . . . . .	About 12 days.
Scarlet fever . . . . .	1 to 3 days. Max. 6 days.
Enteric (typhoid) . . . . .	12 days or more.
Chicken-pox . . . . .	About 14 days.
Small-pox . . . . .	About 12 days.
Diphtheria . . . . .	2 to 10 days.
Influenza . . . . .	1 to 4 days.
Whooping cough . . . . .	About 12 days.
Mumps . . . . .	1 to 3 weeks.

Other infectious diseases are cholera, membranous croup, erysipelas, typhus, relapsing and continued fever, puerperal fever, plague, pulmonary tuberculosis.

A death rate is calculated from the number of deaths per 1000 of those living at the time. For example, the death rate in any town for a given month may be at the rate of 20 per 1000 of the population per annum. Take 1000 people, at the rate of 20 per 1000 all would be dead in  $\frac{1000}{20} = 50$  years, but their ages at death would have been 0 to 50, or a mean of 25 years. If the death rate be put as  $x$  per 1000 the average age at death will be  $\frac{500}{x}$ , thus 15 per 1000 =  $\frac{500}{15} = 33$  years. Dr. B. W. Richardson was of opinion that full attention to hygiene would bring the death rate of the kingdom down to 5 per 1000, then  $\frac{500}{5} = 100$  years *average* age at death. The expectation of life may be calculated approximately, thus,  $\frac{86 - \text{age}}{2}$  which for 30 years present age would give an expectation of  $\frac{86 - 30}{2} = 28$  years more to live.

#### EXAMINATION QUESTIONS RELATING TO CHAPTER XIV.

1.—State, in their order of efficiency, the soils suitable for broad irrigation, and give the ratio of population per acre that would yield the best result in each case when the sewage is applied direct to the land. To what extent could the acreage be reduced if the sewage were first treated in settling tanks?

2.—In designing a sewerage scheme for a town with a population of 20,000 persons on the partially separate system, where there are 12 acres of suitable land available for sewage treatment, what are the first points to be considered and what particulars would you ascertain to enable you to design the scheme?

3.—What are the special advantages of (a) irrigation, (b) bacterial treatment, in relation to the disposal of sewage?

4.—How would you advise a sanitary authority to dispose of excreta in a small town with a water-logged subsoil? How would you dispose of the slop waters?

5.—Discuss the advantage of a chemical, as opposed to a bacterial, method of purifying sewage. Which would you choose, and why?

6.—What are the conditions essential to success in treating town sewage by intermittent downward filtration through land?

7.—Describe two methods of treating sewage. Give sketches of the one you prefer.

8.—A "septic" tank of sufficient capacity to hold one-and-a-half days' flow of sewage is to be constructed for a household of 15 persons, supplied with water from a public main. Give the necessary dimensions of such a tank, and show by a sketch how it should be constructed.

9.—What method would you recommend for dealing with the refuse and waste waters in a country house where earth-closets are in use?

10.—Describe how you would dispose of the sewage, rainfall, and house refuse from a mansion in the country, with 10 acres of land thereto.

11.—Describe briefly two well-known methods of sewage purification. State the action which takes place in each case.

12.—What methods have been proposed for the treatment of sewage? Upon what principles do they depend? Describe any one method in detail.

13.—Describe the best methods of sewage and refuse disposal in a rural district where there is no system of drainage.

14.—Describe an up-to-date system of sewage disposal suitable for a district of 10,000 population, taking a dry-weather flow of 40 gallons per head per day, and state how you would deal with storm water. Give dimensions wherever possible.

15.—If 20 tons of sewage sludge containing 90 per cent. of moisture be reduced to 15 per cent. of moisture, what would be the weight of the solids remaining?

16.—What is the standard of purity for sewage effluent as laid down by the Local Government Board? What tests would you apply to ascertain whether the effluent was within the standard?

17.—You have to prepare a sewage scheme for a compact village with a population of 500 persons. Describe what, in your opinion, is the best method to adopt.

18.—Describe the difference between a contact bed and a continuous filter, state which you prefer and give your reasons.

19.—What do you understand by the natural or biological purification of sewage? Describe any one installation for this purpose with which you are acquainted.

20.—It is proposed to convey the sewage of a town by an outfall sewer to discharge into a tidal estuary. State what conditions should be observed in order to prevent pollution of the foreshore.

SECTION VI.  
MATERIALS AND CONSTRUCTION.

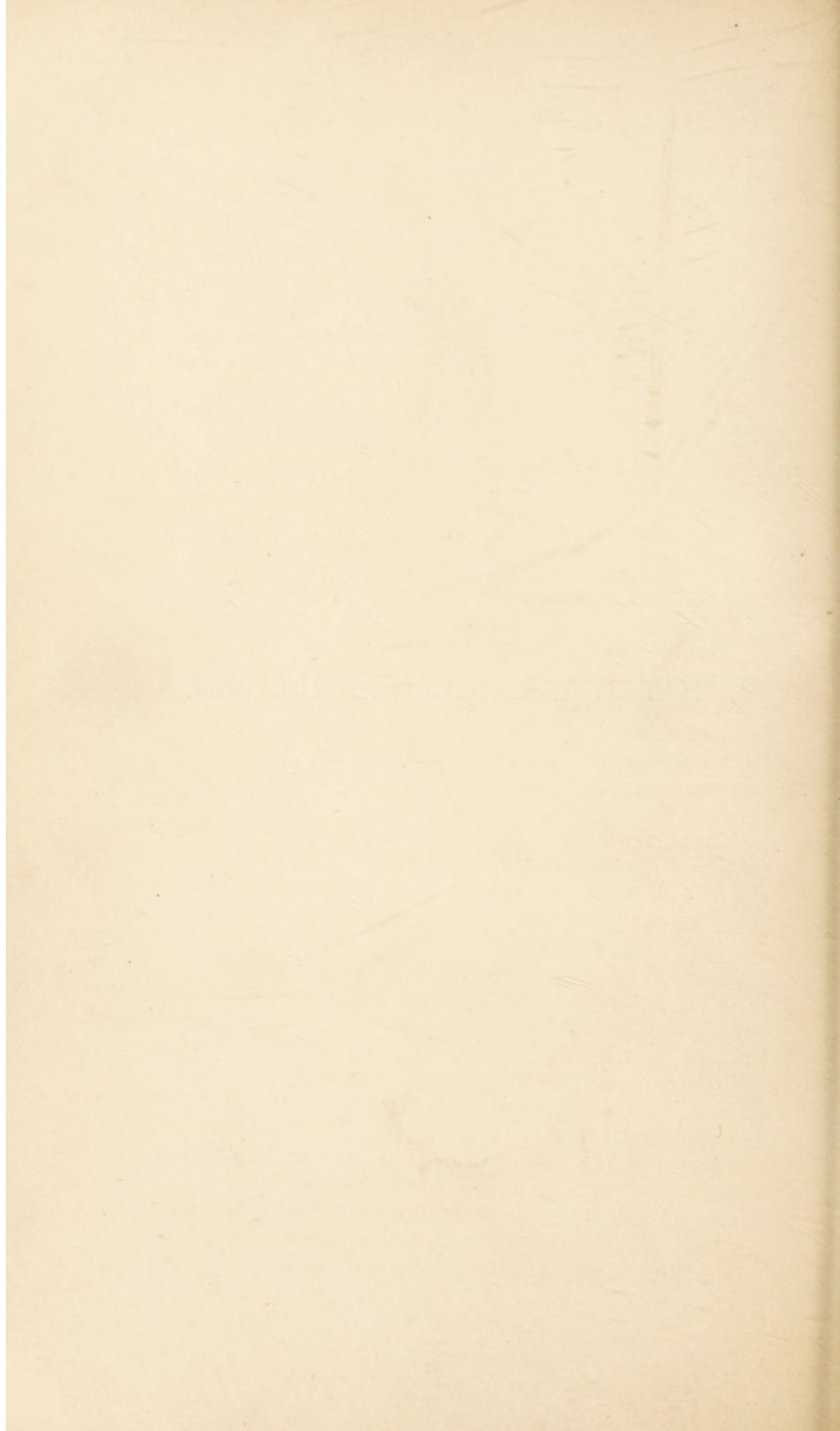

## CHAPTER XV.

General description of materials used in construction, namely, metals, timber, cements, mortars, concrete, stones, bricks and tiles, terra cotta, stoneware, materials for covering roofs, and materials used for preservation and decoration, such as rendering, plaster work, paints, and varnishes; as to their perviousness to moisture, conductivity of heat, facility of working and using, strength, durability, power to withstand fire, purposes for which suitable.

THE metals used in construction are wrought-iron and cast-iron, mild steel, lead, zinc, copper, bronze, brass, and solders.

**Wrought-Iron** is fibrous, tough, and ductile, easily forged, hammered and rolled when hot to various sections. Contains  $\frac{1}{4}$  per cent. carbon and is easily oxidized. Used for bolts, nuts, and washers, and still to some extent for tie rods and flat plates.

**Cast-Iron** is crystalline, brittle, fluid at high temperatures, takes complicated shapes by casting in a mould. Contains from  $1\frac{1}{2}$  to 5 per cent. of carbon. Used for brackets, railings, pipes, gutters, columns, etc. Strong in compression but weak in tension.

**Steel** is of two principal kinds, mild steel and cast steel. Mild steel contains little carbon, and differs from wrought-iron chiefly in the mode of manufacture, which renders it close grained, tough, and strong. It can be rolled to various sections, hammered or forged, and with care may be welded, but it must not be worked at a "blue heat," that is, between  $450^{\circ}$  F. and  $600^{\circ}$  F. It is used for rolled joists, angles, tees, channels, plates, rivets, bolts, nails, rods, bars, and tension members of all kinds. Cast steel contains much more carbon up to  $1\frac{1}{2}$  per cent., is crystalline but hard and strong. Used for base blocks for steel stanchions. Tool steel is somewhat similar but fine grained and much tougher.

**Malleable Cast-Iron** is ordinary cast-iron, in any form of casting, which is heated in contact with oxide of iron or powdered red hæmatite to convert the metal partially into wrought-iron by the abstraction of some of its carbon.

To distinguish between wrought-iron, steel, and cast-iron: If made red-hot and hammered, cast-iron or malleable iron will fly to pieces. If plunged in water while red-hot, steel will harden, while wrought-iron will remain soft. They are also distinguishable by the grain of the fractured surface.

**Stainless Steel** owes its property of non-corrosion to  $12\frac{3}{4}$  per cent. of chromium and  $\frac{1}{2}$  per cent. of cobalt, with  $\frac{1}{4}$  per cent. of carbon; an acid-resisting material may be formed with 15 per cent. of silicon, but it is too hard for general use.

**Lead.**—Sp. gr. 11.33, melting-point,  $620^{\circ}$  F. Soft, easily bent, but not ductile, wears well and resists atmospheric action. Cast lead is rolled under metal rollers to make milled lead, which is the form most used. The different thicknesses are known by their weight in lb. per foot super, usually 3 to 8 lb. ft. sup. The sheets are generally about 30 ft. long and 6 ft. wide, but may be obtained up to 8 ft. wide. Some architects prefer to use cast lead in thin sheets as being less liable to crack if exposed to changes of temperature. Lead water pipes are very largely used, they are made in 12 ft. or 15 ft. lengths, and coils of 36 ft. or 60 ft. Their weight in lb. per yard is approximately, diameter in eighths  $+ 1$ . "Laminated sheet lead," rolled very thin, is used under paper on damp walls.

**Zinc** has practically the same weight as cast-iron, although from being handled in thin sheets one suspects it to be much lighter. It is a crystalline metal but is malleable at about  $225^{\circ}$  F., and is then rolled into sheets. It melts at  $775^{\circ}$  F., and burns in the open air with a bright blue flame. It is used for tall-boy chimney pots, ventilators, etc., also for gutters, flashings, and flats, instead of lead, as it is cheaper in first cost. In a town atmosphere, owing to the acids in the atmosphere, it rapidly corrodes into holes. Its greatest use is for coating or galvanizing wrought-iron corrugated sheets for the walls and roofs of sheds.

**Copper** is found in a metallic state and is also produced from calcined ores, melted and run off into water to granulate it, remelted and run into pigs, which can be hammered or rolled into plates and bars. Pure copper in thin sheets may be used for roof work, for laundry coppers, kettles, and household

utensils, but its chief use is for alloying with other metals, viz. with tin to form bronze and with zinc to form brass.

**Bronze** is an alloy of, say, 10 parts of copper to 1 of tin, but the precise mixture varies according to the object in view, more tin increases the hardness.

**Gunmetal** is a form of bronze, but contains some zinc, say 16 copper, 2 tin, 1 zinc. It is used for window-frames, door furniture, and the best class of valves and cocks.

**Brass** is known as high or low, according to the proportion of zinc contained. High brass is 2 copper to 1 zinc, low brass is 4 copper to 1 zinc. The colour varies with the proportion of zinc, increasing in yellowness as the zinc increases. A little lead is generally added, which causes it to work easier in turning and filing. "Potmetal" is a common brass with excessive lead used for cheap work. Brass is used for a great variety of purposes where it is desired to have a metal of good appearance that will not rust; it, however, goes green by the formation of a carbonate of copper, or ambergris, if not kept clean, particularly if any grease comes in contact with it.

**Solders** are used for joining pipes and sheets of lead, zinc, and tinned iron. Tinmen's, or hard solder, is composed of 2 parts tin to 1 of lead, plumber's, or soft solder, is composed of 1 tin to 3 lead. Joints in brass or cast-iron can be brazed with spelter composed of 3 copper 2 zinc.

**Plumber's Wiped Joints** in lead pipes are made with soft solder. The upper pipe is scraped bright and tapered slightly at the end, the lower one scraped and slightly coned inside. "Soiling," composed of lamp-black and size, is then painted on the outsides where the solder is to leave off, and the molten solder is shaped round the joint with a moleskin cloth in the plumber's hand. The length of the wiped joint should be one-quarter diameter of pipe +  $2\frac{1}{2}$  ins. The quantity of solder in lb. required to make a wiped joint is  $1.05d + .25$ . A blown joint, or blow-pipe joint, is made by widening the lower pipe to a greater extent and filling the projecting portion with solder melted by a blow-pipe. It is a slovenly joint, very weak, and not allowed in good work.

**Fir.**—The timber most in use is from the Scotch fir, or *Pinus sylvestris*. It is called "fir" when used rough sawn, and "deal" when planed. It is marketed chiefly in planks 11 ins. by 3 ins., deals 9 ins. by 3 ins., battens, 7 ins. by 2 ins., also in whole timbers, Swedish and Norwegian, 10 ins. square, Riga

12 ins. square, Memel 13 ins. square, Dantzic 15 ins. square. It is a soft wood and easily worked. Sometimes called red deal.

**Spruce** or white deal, from the *Abies excelsa*, is a commoner wood of the same class used for cheap joinery and packing cases. It is a stringy wood, with hard knots and occasional veins of resin.

**Patternmaker's Pine**, or Weymouth pine, is a very soft wood of uniform grain, used, as the name implies, for making patterns for moulding castings. Also for mouldings in joinery, and for panels on account of its large size.

**Oak**, English, American, or Dantzic, is a hard and heavy wood, lasting well when exposed to the weather, but too expensive for common use. Ordinarily used for window-sills and thresholds of outer doors, and for window-frames, sashes, and doors in high-class joinery.

**Pitch Pine** is of the fir and pine tribe, but is harder than the others and the grain is more strongly marked. It shrinks and expands with the weather. It is used chiefly for joinery that is to be simply varnished and for flooring subject to rough usage.

**Elm** is a hard wood with very coarse and irregular grain. Lasts well if kept dry or constantly exposed to moisture, but decays rapidly if alternately wet and dry. Used chiefly for coffins.

**Teak** is a hard wood used for similar purposes to oak, also for ship and railway work.

**Roman Cement** is made from the nodules found in the London clay, composed of 50 per cent. clay, 40 per cent. lime, 10 per cent. oxide of iron, etc. It sets rapidly, and is used for tidal work and for setting coppers. It attains a strength of only about 70 lb. sq. in.

**Keene's Cement** is made from gypsum (plaster of Paris, sulphate of lime) hardened by steeping the calcined stone in borax and cream of tartar in solution, drying and reburning, then grinding to powder. It is used for skirtings and the angles of plastering.

**Portland Cement** is made from chalk and Thames mud or clay, 62 parts of the former to 38 of the latter, ground together into a slurry or slip, burnt and ground to a fine powder. It is used in making concrete and artificial stone, rendering damp walls and for many other purposes. The tests for Portland cement are briefly : Specific gravity, 3.1. For soundness a pat is made and placed in water at 120° F. for 24 hours. For

fineness,  $\frac{1}{2}$  per cent. residue on 50 meshes to the inch, 1 per cent. on 76 mesh, 14 per cent. on 180 mesh. Rate of set, not less than 30 minutes to commence setting nor more than 5 hours to set hard. For expansion, not more than 10 mm. by the Le Chatelier test. For strength, at 3 days 350 lb. sq. in. (being put in water 24 hours after gauging), 450 lb. sq. in. at 7 days, 550 lb. sq. in. at 28 days. A cubic foot of Portland cement is assumed to weigh 90 lb. For a rough test on the works, a pat 3 ins. diameter and  $\frac{1}{2}$  in. thick at centre, thinned off to the edges, may be made on a slate and its properties noted. In 24 hours there should be no cracking at the edges and the pat should not allow of marking by the thumbnail.

**Mortar** for bricklaying is composed of 1 part ground stone lime, or blue lias lime, to 2 or 3 parts clean sharp sand. The most durable joint is that used by engineers and specified as a "neat struck joint as the work proceeds," it should bevel downwards and outwards so as to throw off the rain.

**Cement Mortar**, used for laying blue bricks, and sometimes for hard stock bricks, is composed of 1 part Portland cement to 3 parts sharp sand. In equal parts of cement and sand it is used for jointing stoneware drain-pipes.

**Concrete** was formerly composed of 6 parts of ballast and sand mixed, to 1 part of stone lime, forming lime concrete. This is now obsolete, as where concrete is required cement concrete has overpowering advantages. Cement concrete for foundations is usually composed of 1 part British Standard Portland cement to 3 parts clean sharp sand and 6 parts screened flint ballast, broken stone, or hard broken brick, measured separately, thoroughly mixed dry on a wooden platform, and afterwards, while being watered through a rose, with, say, 6 gallons of water per cubic foot of cement. The mixing should be continued in the first case until the colour is uniform and in the second case until the whole is thoroughly moistened, but not sufficiently for any water to run off. A cubic yard of 1 : 3 : 6 concrete requires 4.18 cub. ft. or 376 lb. cement, 12 $\frac{1}{2}$  cub. ft. sand, 25 cub. ft. large aggregate, and 20 gallons of water. For reinforced concrete the usual mixture is 1 part slow or medium setting Portland cement, 2 parts sand, 4 parts broken sandstone or hard brick. The sand should vary, if possible, between  $\frac{1}{8}$ -in. and  $\frac{3}{8}$ -in. gauge, the broken stone between  $\frac{1}{4}$ -in. and  $\frac{3}{4}$ -in. gauge. The mixing should be very carefully done, not more than  $\frac{1}{2}$  cub. yd. at one time, and all put in place

within one hour. The steel reinforcement is usually 0.675 per cent. of the effective sectional area of the concrete, and is calculated to bear a tensile stress of 16,000 lb. sq. in., the concrete being under a compressive stress of 600 lb. sq. in. No form-work should be removed for 7 days, and important parts should be supported for 21 days. Coke breeze concrete is only suitable for interior work where no moisture can reach it.

The stones in use for building are granite, sandstones, and limestones :—

**Granite** is a very hard, crystalline stone, and, therefore, an expensive stone to work, used for steps, plinths in large buildings, etc. Used in roads as macadam, broken to 1½-in. gauge, and as kerbs, channels and pitching. The small chips made in working granite are screened from the dust and used in making "granolithic" for surfacing concrete floors. Granite is not fire-proof, as it flies under heat.

**Sandstones.**—York stone is the best known, used for pavings, sills, copings, etc. When broken to ¾-in. gauge and under it makes a good aggregate for reinforced concrete. York stone is used for scullery sinks, but glazed stoneware is cleaner and non-porous, and therefore better.

**Limestones** are largely used for the stonework of buildings, but they are subject to cracks and sand pockets. Box-ground Bath stone is the only good weathering stone of its class. Portland stone is more expensive, but has the advantages of being stronger and weathering better. There are three chief beds, the roach, whitbed, and basebed. The roach contains the Portland screw fossil and is used for dock work. The whitbed is mostly used in building. The basebed is sometimes substituted for the whitbed but is not so good. Marble is a crystalline limestone. Limestones are bad fire-resisters, as being chiefly carbonate of lime, the carbonic acid is driven off by heat and the stone crumbles. On this account they are not used for aggregate in reinforced concrete.

**Slate** is a variety of stone composed of clay subjected to natural heat and pressure during its formation with other geological strata. Owing to its cleavage planes it can be split into thin laminæ. It is used for roof covering and for pantry shelves. The roofing slates mostly used are the Countess size, 20 ins. by 10 ins., laid with a 3-in. lap.

**Bricks** are made by putting brick earth through a pug mill with sufficient water to moisten it, pressing the clay in

moulds and burning the bricks so formed in a kiln or clamp to harden them and make them weather-resisting. The burning should be carried to incipient vitrification. Blue Staffordshire bricks are the hardest and best. Used for the invert of sewers, for plinths, warehouse door jambs, and piers subject to heavy loads.

**Stock Bricks** are the staple bricks of any district. London stocks are a warm buff colour, weathering well. They should resist marking by a knife. A brick weighs about 7 lb.

**Place Bricks** are the soft, underburnt bricks from the outside of the clamp, and only useful for interior brick-nogged partitions.

**Cutters and Rubbers** are made from a clay free from stones, used for arches, window and door jambs. They should resist marking by the thumb nail but not by a knife.

**Glazed Bricks** are either "salt-glazed" or "dipped." The former is done by throwing salt into the kiln during the burning, leaving the natural colour to show through the glaze. Dipped bricks are of any desired colour, being dipped into a "slip" of specially prepared clay, either before burning or when half burnt, giving a china-like coating to the brick. They are used to reflect the light when buildings are close, or for facility in cleaning in manholes, etc.

**Fire-bricks** are used for setting furnaces, coppers, and boilers. They are made from clay containing a large proportion of silica and a little alkali. Dinas fire-bricks are the best, but Stourbridge bricks are good.

**Tiles** are made of a fine clay, generally expressed from the machine in thin bands and wire-cut to length, curved and perforated by hand, then burnt. Pantiles are corrugated, and only used for sheds and rough work. Plain tiles,  $10\frac{1}{2}$  ins. by  $6\frac{1}{2}$  ins., are used for ordinary roofing.

The materials used for covering roofs are slates, tiles, asbestos-cement or uralite sheets, corrugated iron, lead, zinc, copper, concrete, ruberoid, asphalte, wood shingles, tarred felt, thatch, weather-boards, etc. These are all impervious to moisture, if properly laid and lapped. To reduce the passage of heat or cold through a roof covering an inner lining of sarking or roofing felt is desirable. Galvanized iron or slates may be whitewashed externally in the summer if there is no inner protection to keep out the heat.

**Rendering in Plaster** is done upon the wood or metal laths

of partitions and ceilings, and upon the interior of brick, stone, or concrete walls, to give a smooth porous surface and to absorb the temporary deposition of moisture that occurs upon a sudden rise of temperature. It is generally in three-coat work, the first coat is "coarse stuff" of 1 part fresh burnt chalk lime to about  $1\frac{1}{2}$  parts of sand, well slaked together and mixed with about 1 lb. ox hair to each 2 cub. ft. of stuff. This first coat is called "rendering" when on brickwork, and "plastering" or "pricking-up" when on laths. Pricking-up is deep scratching with the end of a lath to form a key for the next coat. The second coat is similar but without hair; it is known as the "floating coat," and is used to bring the whole to a true surface. The third or finishing coat is composed of "fine stuff," or pure lime slaked, water added, stirred, allowed to settle, and used when water drawn off or evaporated. This is when the wall is to be papered. If it is to be distempered or painted the finishing coat is of "plasterer's putty," similar to fine stuff, but more carefully made and strained through a fine sieve. If a little plaster of Paris is added to make it harder it is known as "gauged stuff," and is used for better-class work and for running cornices.

**Rendering in Cement** is used inside wells, reservoirs, and manholes to render them waterproof. A mixture of 1 part Portland cement to 3 parts sand may be used, the usual thickness is  $\frac{3}{4}$  in. to 1 in. The joints must be well raked out first to give a good key to the rendering.

**Paints**, as a rule, have a "base" of white lead, ground and mixed with linseed oil as a "vehicle," dry colour being added according to the tint required. In addition, some "solvent," as turps, to cause the paint to flow freely, and some "drier," as litharge, to expedite the drying and hardening. In painting on plaster it is necessary to give a coating of size first to stop the "suction," that is, the absorption of oil from the paint before it can dry. The full description of the process of painting an internal grained and varnished door is as follows: The door being cleaned off to dimensions, or tried up in place, is well rubbed down with fine glass paper and dusted with a bench brush. The knots are then "killed," or covered with red lead and size, glue, patent knotting, or tinfoil to prevent the exudation of turpentine or resin from discolouring the finished work. When dry the knots are smoothed with pumice stone and the priming coat laid on. This is the FIRST COAT of

oil colour, and is composed of  $\frac{1}{2}$  lb. red lead, 16 lb. white lead, 6 pints raw linseed oil,  $\frac{1}{4}$  lb. driers per 100 yds. sup.; it closes the pores of the wood and prevents the oil from the putty and the after-coats of paint from being absorbed by the wood. When dry the holes are stopped with glaziers' putty and the whole surface pumiced over and dusted. In common work the priming coat, called "sheepskin," consists of red ochre, water, and size. The SECOND COAT consists of 15 lb. white lead,  $3\frac{1}{2}$  pints raw linseed oil,  $1\frac{1}{2}$  pints turpentine,  $\frac{1}{4}$  lb. driers per 100 yds. sup. When this is dry and hard it is rubbed down with pumice and the THIRD and FOURTH COATS put on in a similar manner, consisting each of 13 lb. white lead,  $2\frac{1}{2}$  pints raw linseed oil,  $1\frac{1}{2}$  pints turpentine,  $\frac{1}{4}$  lb. driers per 100 yds. sup., with sufficient ochre or umber to give a light stone colour. The GRAINING COAT is then put on, consisting of burnt umber, raw oil, and driers mixed thin, and while still wet is "combed" or scratched with steel, horn, or wood combs to imitate the grain of oak, the "flower" being produced by pieces of rag, sponge, etc. In best work another coat is laid on called "over-graining," consisting of raw umber mixed with stale beer, enabling a more complete imitation to be produced. It is then finished with TWO COATS BEST HARD COPAL VARNISH. The above routine is technically described as "clean, rub down, knot, prime, stop and paint 3 oils, grain wainscot, overgrain, and twice varnish with best copal." If to be finished without varnishing, the last coat would be a "flattening" coat, to give a dull or matt surface, which is effected by omitting the linseed oil from it and using only turps. For outside work, if the paint is to be exposed to the sun and weather, boiled oil should be used and the quantity of turps in the second coat should be reduced to about one-half of that mentioned for inside work, and there should be no turps used in the remaining coats, except in winter.

**Paint for Ironwork.**—Red oxide of iron is the usual base with boiled linseed oil as the vehicle, but lead paints may be used. For iron tanks a bituminous paint should be used, such as Wailes Dove & Co.'s bitumastic solution.

## EXAMINATION QUESTIONS RELATING TO CHAPTER XV.

- 1.—What causes the decay of stonework in manufacturing towns? How can the stone be treated to preserve it from decay?
- 2.—How would you determine the most important points in selecting building bricks for works of various kinds, including fire-bricks?
- 3.—Name the different kinds of bricks used in building. What are the relative advantages of each?
- 4.—Describe the characteristics of a good building brick. Why should bricks be wetted before being laid?
- 5.—What means are available for preserving building stones from decay?
- 6.—What are rich or fat limes? What are their uses, and what precautions must be taken in using them?
- 7.—Give a list of the various materials used for internal wall plastering, and the uses for which each is best suited.
- 8.—Explain the meaning of the terms "rich," "poor," and "hydraulic," as applied to limes. State how they are obtained, and how they are used by builders.
- 9.—What are the characteristics of cast-iron, wrought-iron, and steel, and to what particular forms of construction are they especially adapted?
- 10.—State the composition and advantages of asbestos slates, or others of that character. Show, by sketch, what is meant by the lap of slates.
- 11.—What is the difference between milled and cast lead; how are the drips and joints formed in covering a roof with lead?
- 12.—What are the chief differences between wrought-iron, mild steel, and cast-iron?
- 13.—What conditions are favourable to the appearance and extension of "dry rot" in a dwelling?
- 14.—Describe the importance of ventilating the space beneath floor-boards. Name three kinds of timber that best resist the action of moisture.
- 15.—What is "dry rot," how does it originate, how is it cured, and how prevented?
- 16.—What is the difference between "white lead" and "red lead"? How is each manufactured? Can white paint be made without using the former? If so, how?
- 17.—Describe any processes known to you for preserving timber. Explain dry and wet rot; and how can each be prevented?
- 18.—Describe the manufacture of good bricks, and the composition

of lime mortar, cement mortar, and concrete intended for drains and foundations.

19.—What are the different kinds of timber used in building construction. For what class of works are they respectively used, and what defects are to be avoided in their selection?

20.—What is milled lead? What is cast lead, and what are the objections to the same? Give the weights of lead you would recommend for (a) large flats; (b) gutters; (c) hips and ridges; (d) aprons; (e) trays under W.Cs. and baths.

21.—Name four impervious building materials. State in what positions they should be used and why.

22.—Describe the qualities and composition of good brickwork, concrete, and mortar.

23.—What materials and what quantity of each would you require to make a cubic yard of concrete for foundations?

24.—What is the average depth of vegetable soil, and how deep should the foundations of a building go on clay and gravel respectively?

✓

## CHAPTER XVI.

General principles of construction as applying to: Foundations in various soils—Walls, hollow walls, damp course, bond—Floors for basements or cellars, fire-proof partitions—Roofs, covering for same, gutters, hips, valleys—Fire-proof construction.

UNHEALTHY situations are, generally speaking, those which are low-lying, especially if on marshy ground or surrounded by large trees. Some situations are rendered unhealthy, although not naturally so, as by the construction of cemeteries, hospitals, refuse destructors, brick yards, chemical works, sewage farm, etc. Unhealthy soils are clay, peat, and made earth, especially if the subsoil water level is near the surface. Some are only indirectly unhealthy, as chalk, from the hard water it furnishes. Sand and gravel are generally good, but if subsoil water is within 4 ft. of the surface the site will be unhealthy.

**Precautions to be Adopted.**—Build on high ground, and if on side of hill, direct water from higher ground away from site. Drain off subsoil water. Remove large trees from immediate vicinity. Lay 6 ins. cement concrete over site. Build damp-proof course in walls. Protect walls exposed to driving rain or sea spray by tarring, covering with slates on battens, or hanging tiles, or facing with glazed bricks pointed in cement, or rendering in Portland cement, or constructing the walls with an outer skin and an air space. Provide air bricks for ventilating floors.

The principal sources of unhealthiness in dwellings are: Building on made ground, wet subsoil, damp walls, absence of damp-proof courses, insufficient depth below floors, rotten floors, dead vermin, drains untrapped or leaking, ventilating shafts improperly placed, poisonous wall-papers, non-removal of old wall-paper, leakage of gas, broken slates and defective

gutters, low ceilings and small windows, fire-place openings and flues blocked up, polluted water supply, foul cisterns, non-removal of house refuse. The chief enactments which give control over these matters are the Public Health Acts, 1875 and 1891, the Housing of the Working Classes Act, 1890, the London Building Act, 1894, and various By-Laws of the County and District Councils.

On the other hand, the essential points of healthy construction are : a site which is clean and dry ; efficient protection from the admission of air and moisture from the subsoil into the house ; walls and roof which will effectually keep out wet, and, to some extent, be proof against fluctuations of heat and cold ; materials sound in quality and free from organic impurities ; rooms of sufficient size for habitation, properly lighted, and provided with suitable means of ventilation.

In setting out works of construction from a drawing the

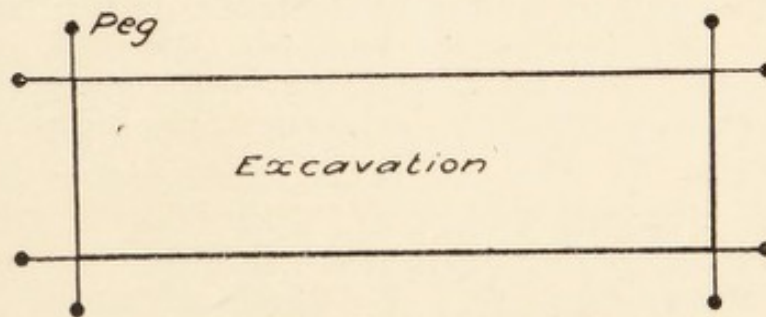

FIG. 92.—Pegging out excavations.

outline of the excavation is nicked in with a pick or edge of a spade, or marked on the ground by cords fastened to pegs placed clear of the excavation, as in Fig. 92. The levels are obtained by working with an ordinary spirit level, or with a surveyor's level and tripod, from some given point in the immediate neighbourhood. Ordnance datum, from which the levels are given on Ordnance maps as " $\wedge$  B.M.25.3," is supposed to be the mean half tide sea level at Liverpool marked at the entrance to the Mersey docks, but it is really 0.65 ft. below the true level. Drawings for sewerage have the levels of the inverts given always in connection with the Ordnance datum, and the work is carried out by levelling from the nearest Ordnance bench mark, probably cut in the face of a wall at the position of the broad arrow shown on the map.

The foundations should not be less than 2 ft. 6 ins. deep on gravel, and 5 ft. deep on clay. It is desirable to commence

with a bed of Portland cement concrete (1 : 3 : 6 mix.) 6 ins. thick, and 6 ins. wider on each side than the bottom course of footings. There should be as many courses of footings as there are half-bricks in the thickness of the wall, each one projecting  $2\frac{1}{4}$  ins. on each side beyond the course above it. On damp or made ground, or where the subsoil water is liable to rise, the whole site should be covered with at least 4 ins. of Portland cement concrete laid on 3 ins. of broken brick well rammed. The walls should be properly bonded, either English or Flemish bond, the former for strength, the latter for appearance, with king closers in the jambs at window and door openings. Hollow or cavity walls are advantageous for resisting sea spray or driving rain, or merely to keep the interior warmer in the winter. The least total thickness should be 11 ins., viz. 9 ins. for the inner wall to carry the weight of floors and roof, 2 ins. cavity, and  $4\frac{1}{2}$  ins. outer skin for protection, bonded to the thicker wall by wall ties not more than 3 ft. apart horizontally in every sixth course, breaking joint with each other. The ties may be wrought- or cast-iron, with a dip in the middle to throw off any moisture, or glazed bonding bricks joggled so that the tail in the thick wall is one course higher than in the outer wall. Over the window and door heads a strip of lead should be carried, with back turned up and the ends bent down to throw off any moisture. A damp-proof course should be built in the base of all walls not less than 6 ins. above outer ground level and below the lowest wall plate (see Fig. 93). If the floor is too low for this the damp-proof course must be kept below the wall plate and a plinth of asphalt or cement carried up from it to 6 ins. above ground level. The damp-proof course may be of sheet lead, lead wire embedded in bitumen, two courses of slates laid in cement mortar to break joint, or perforated glazed tiles. The latter provide ventilation under the floor as well, but it is often in excess, and some of the holes must then be stopped up. With a solid damp-proof course it is necessary to insert air-bricks below the floor to ventilate it and prevent dry rot. Fig. 94 shows the base of a hollow wall with perforated damp-proof course, and there are several points of detail shown which should be carefully studied.

Dry rot in timber is due to various fungi, of which *Merulius lacrymans* is the most common. It occurs chiefly under ground floors, where the ventilation is insufficient, and especially where there is some warmth, as in kitchen and sitting-room

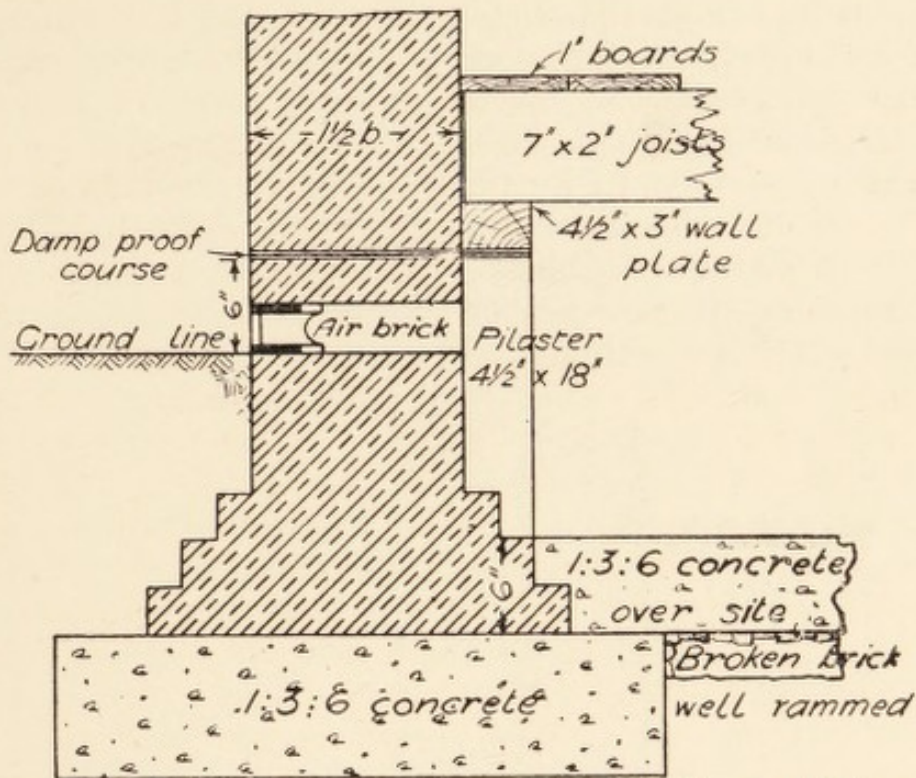
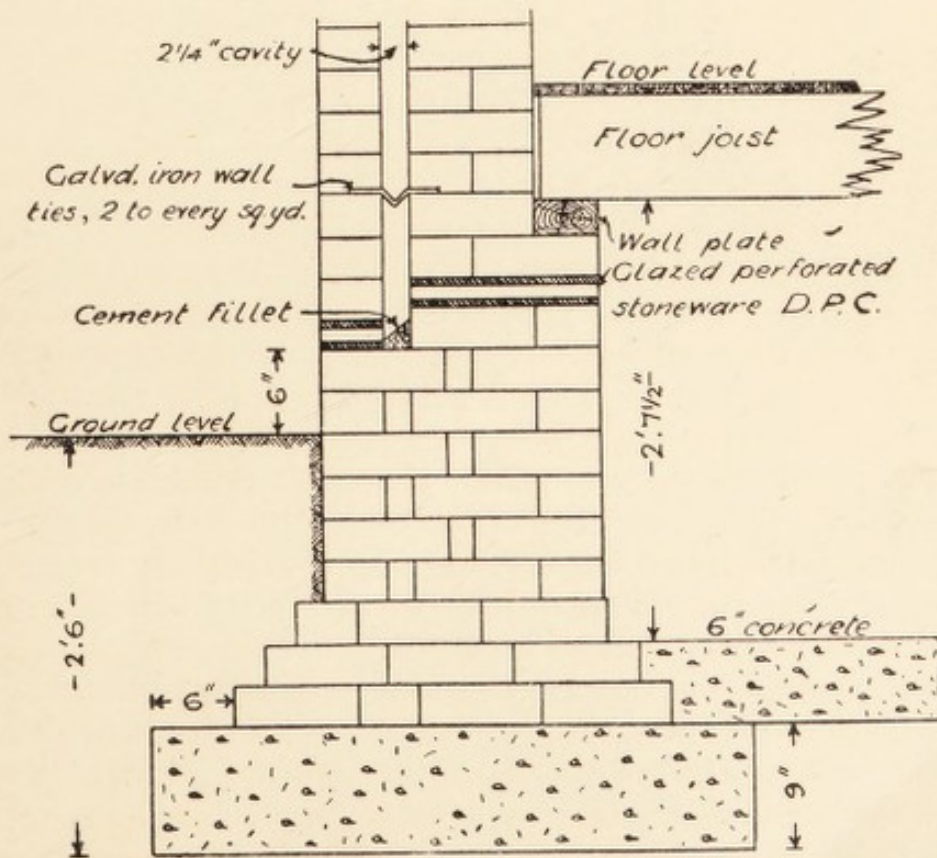

FIG. 93.—Damp-proof course and air brick for ventilation.



HOLLOW BRICK WALL

FIG. 94.—Base of hollow brick wall.

floors. The fungus sends out threads which penetrate the wood and spread over the surface like a brown or grey mat. The ripe spores form a golden-brown dust, which travels about and starts the growth on other timber. In case of an attack, all infected wood must be removed, joints in adjacent brickwork raked out, all surrounding parts sprayed with a saturated solution of corrosive sublimate, the brickwork joints pointed in cement, and the new timber painted twice with the solution. On account of the extremely poisonous nature of the corrosive

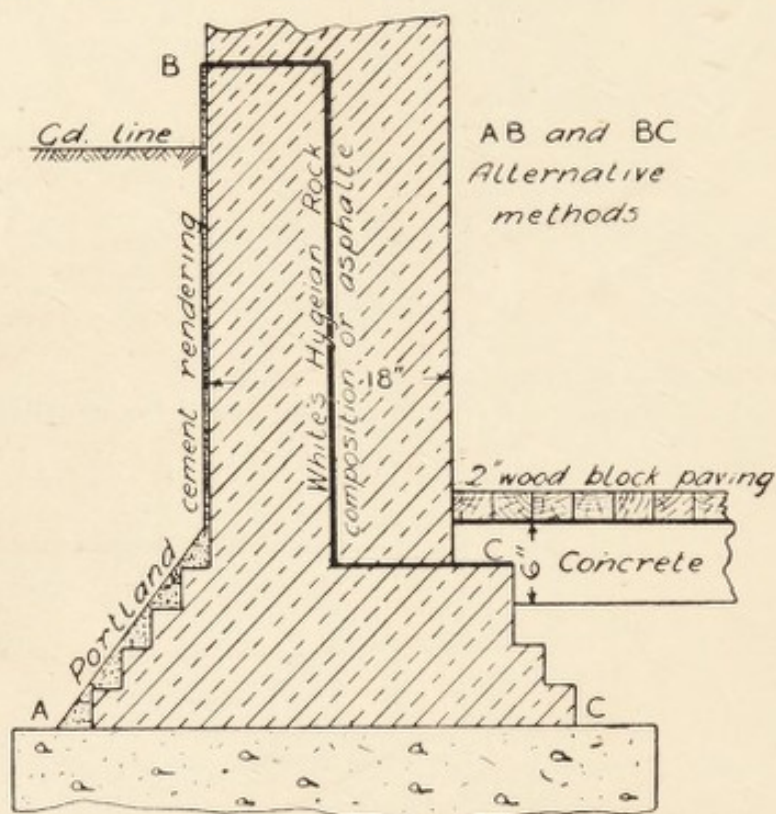

FIG. 95.—Section of cellar wall protected from damp.

sublimate, a solution of sulphate of copper is sometimes used, although not quite so effective. Creosoting the timber is a good preservative, but the smell is objectionable in a house.

Among the causes of damp walls are the want of a brick-on-edge course set in cement at the top, the absence of a damp-proof course near the bottom especially on a wet soil, a south-west exposure or exposure to sea spray, too closely surrounded by trees, defective gutters and down pipes, under-burnt bricks, leaking water pipes, choked rain-water pipes.

When there are basement rooms or cellars special precautions must be taken. The exterior of the walls against which

the earth abuts must be rendered in cement or asphalt, or at least tarred over, or constructed as shown in Fig. 95. The floor of a basement room or cellar can be efficiently constructed of cement concrete, or tiles laid on concrete, and if care has been taken to keep out all moisture linoleum or hard wood blocks may be laid on the concrete.

Panelled wainscot partitions are only fire-resisting for a few minutes, lath-and-plaster partitions for a little longer, brick-nogged partitions are still better, but are soon destroyed in a big fire. Nine-inch brick partitions are fire-resisting so long

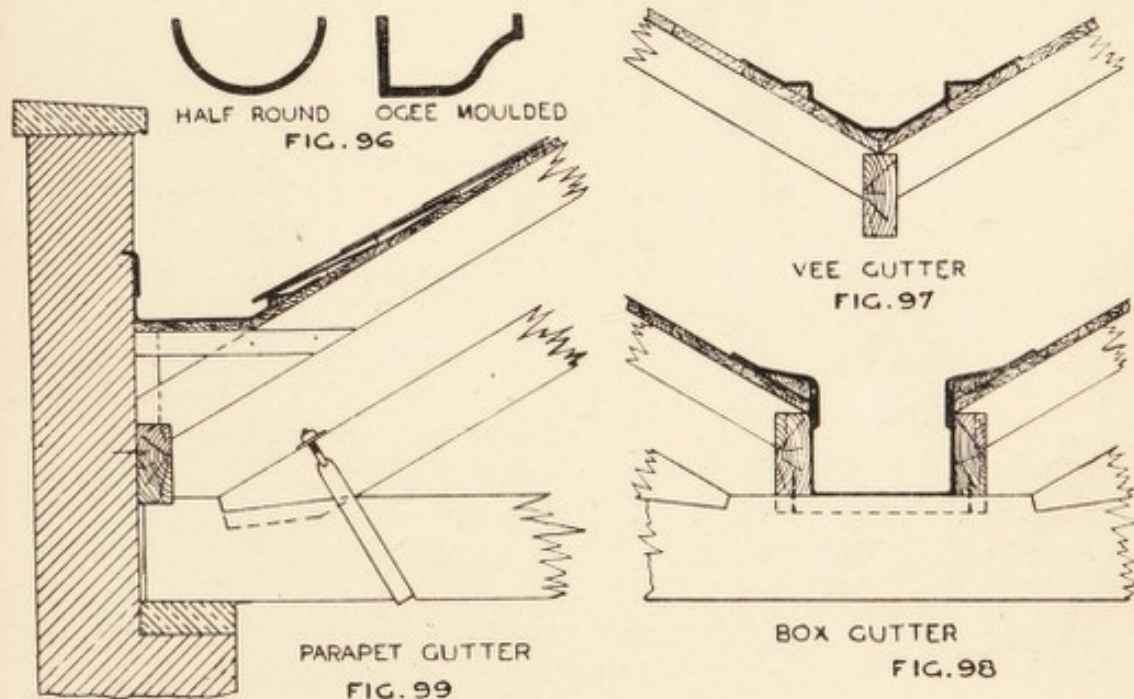

FIG. 96.—Cast-iron eaves gutter.

FIG. 97.—Section through a vee gutter.

FIG. 98.—Section through box gutter.

FIG. 99.—Section through parapet gutter showing foot of roof truss.

as they are not pushed over or undermined. Wood may be rendered more resisting by being sprayed with "Cyanite." "Mack" partitions, of plaster of Paris slabs 6 to 8 ft. long, 12 ins. wide, and  $1\frac{1}{2}$  in. to  $2\frac{3}{4}$  ins. thick, are useful for light fire-proof work. Wired glass for windows or skylights is rendered safer in fires, by having wire netting embedded in its substance. With regard to partitions formed of plaster of Paris slabs the Building Materials Committee of the Munitions Inventions Department reported, in 1920, that they came to the following conclusions:—

1. That properly constructed blocks are sound and reliable.
2. They are suitable for cottage partitions of any reasonable length and height.
3. They are capable of carrying an ordinary weight over a floor of normal span of, say, 15 ft. or 16 ft. The partition would gain in strength when plastered, as would occur in ordinary building construction. They also recommend that if wire reinforcement is used it should be galvanized. The Committee

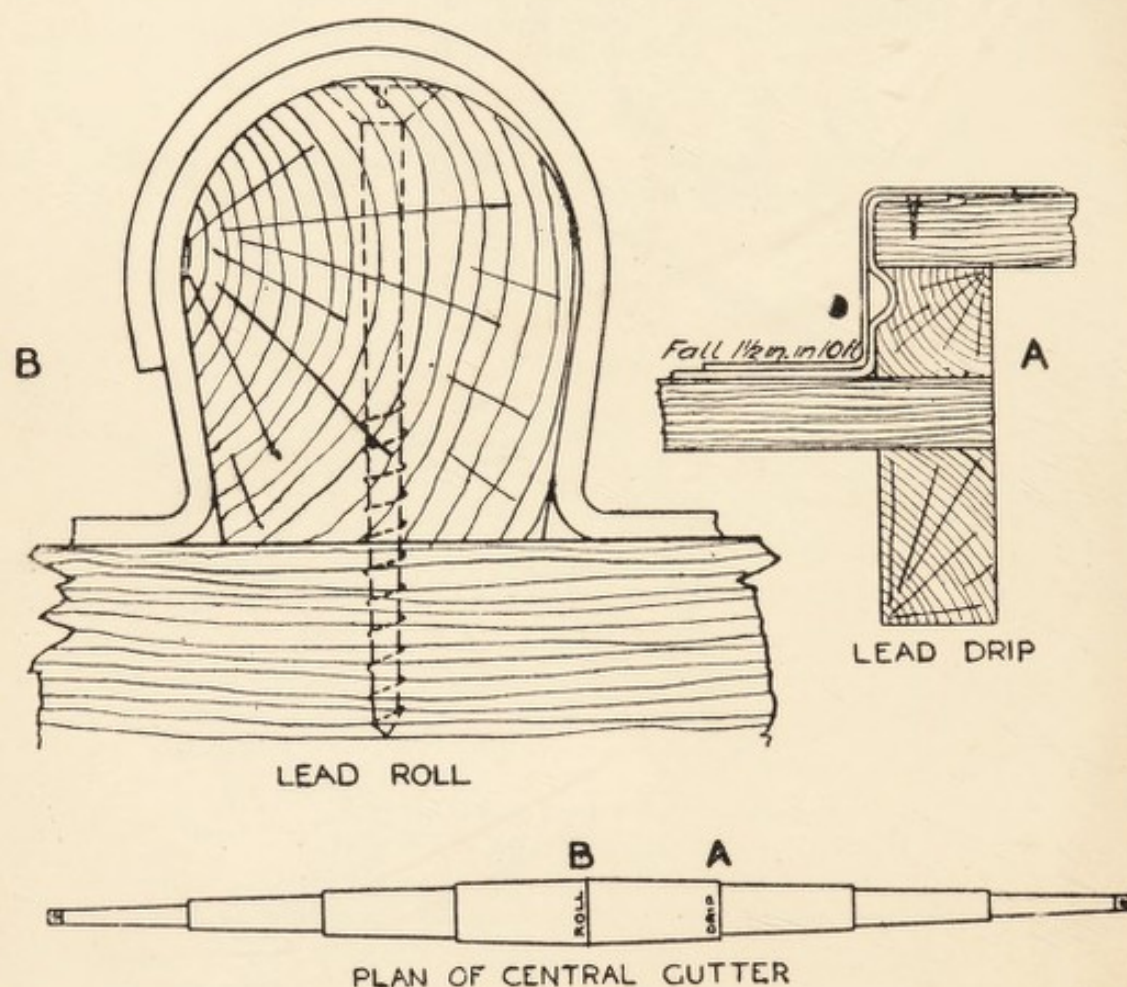

FIG. 100.—Lead work on roof.

suggest that upper floors of cottages may be constructed of light joists with plaster slabs reinforced with galvanized wire rabbit netting and then about 1 in. of hard beaten flooring plaster on top. The Committee are entirely in favour of sand-lime bricks, the commoner kinds for interior and the best for exterior work.

Roof coverings have been referred to previously, but as

regards fire-resistance it should be noted that slates break up at the least touch of a flame, lead melts and zinc burns. Parapet gutters should be lined with 6 lb. lead; 5 lb. lead should be used for flashings, ridges, hips, and valleys; 4 lb. lead for aprons, soakers, cisterns, sinks, and coffins; 7 lb. lead for soil pipes. For best work 1 lb. may be added to each. Zinc is frequently used as a substitute, but it is dearer in the end as it has a comparatively short life owing to the acids in the atmosphere of towns. The plumber's work about a roof is very important.

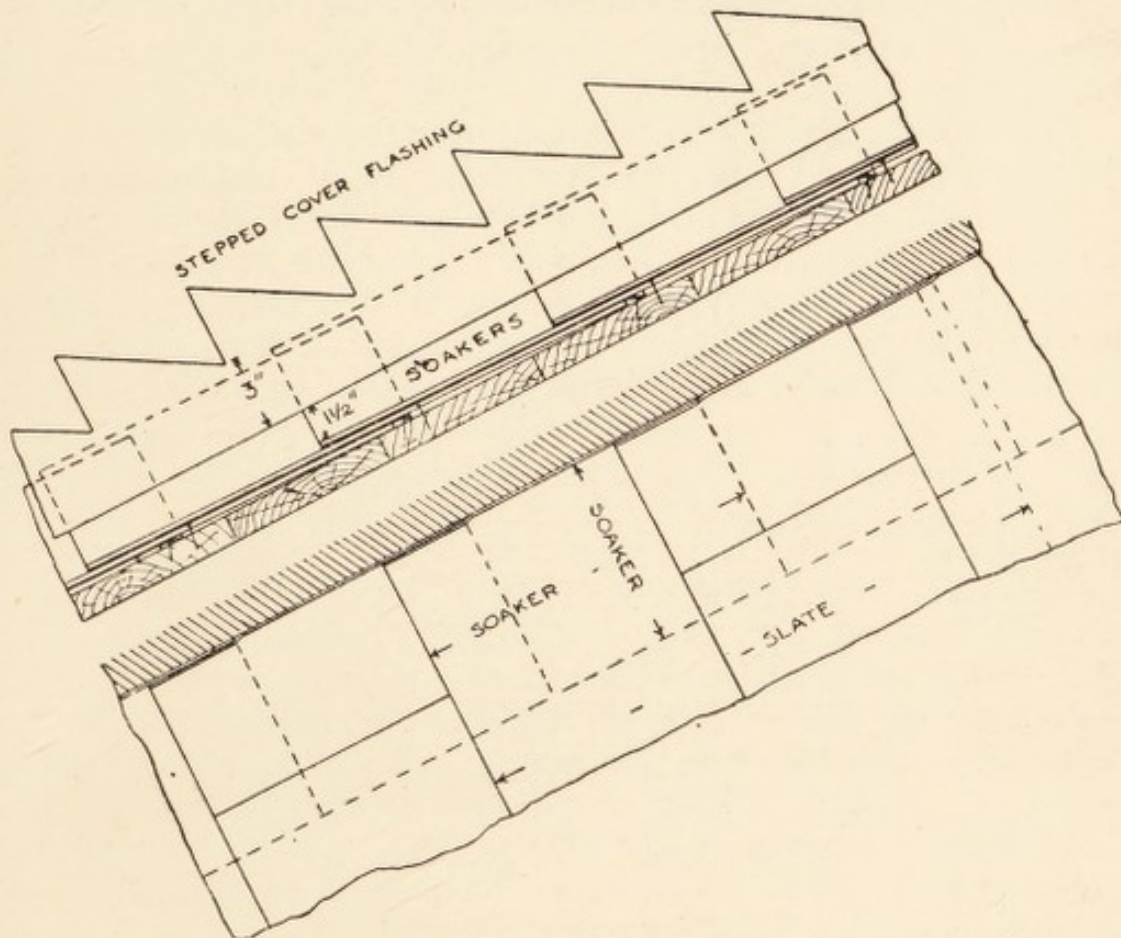

FIG. 101.—Stepped flashing at gable and on chimney stack.

The eaves gutters (Fig. 96) are usually cast-iron, jointed with red lead and screws, and supported by wrought- or cast-iron brackets, or by being screwed direct to a vertical gutter board. The V-gutter (Fig. 97) is used between two roof slopes, or concealed under the slates between two roof planes meeting at an angle. In large buildings the box gutter (Fig. 98) takes the place of the shallow V-gutter. Behind a parapet wall the gutter is formed at the bottom of the roof slope, as shown in Fig. 99. The joints in a lead gutter depend upon the length of the sheets

of lead, but 10 ft. apart is the maximum ; they take the form of a drip or drop of 2 ins., as shown at A (Fig. 100). At the highest part of a gutter the joint is formed by a lead roll as at B. The plan of central gutter or valley gutter shows how the width reduces at each drip because the level is lower down in the angle of the roof planes. A parapet gutter would show the same plan except that the wall side would be straight. Where a sloping roof abuts against a chimney stack or gable wall, special provision must be made for keeping out water by the use of lead soakers worked in with the slates, turned up against the wall, and covered by stepped apron flashing, as in Fig. 101.

Modern fire-proof construction may be considered to be either of reinforced concrete throughout, or of steel frame construction cased in concrete. Special fire-proof floors are of many varieties, chiefly of hollow bricks or tiles reinforced by steel rods and grouted with cement or fine concrete. Fire-proof partitions are of brick, fire-resisting partitions are brick-nogged, half-brick thick, or built up of plaster of Paris slabs.

#### EXAMINATION QUESTIONS RELATING TO CHAPTER XVI.

1.—What are the relative advantages and disadvantages of residences : (a) on hill-tops ; (b) on flat plains or table lands ; (c) in depressed valleys between hills ; (d) on alluvial lands near river estuaries ? Explain, in each instance, the effects upon health.

2.—What precautions should be taken to secure a healthy site for a dwelling-house to be erected (a) upon the side of a clay hill ; (b) upon fen land ; (c) upon a sandy soil containing springs ?

3.—What precautionary measures would you adopt for the prevention of dampness in a house built upon sloping ground, the floors of which at the rear of the house are below the level of the adjoining ground ? Illustrate your answer by sketches.

4.—In a house without underground rooms, at what depth should the footings be placed (a) in gravel, (b) in clay ? What precautions are needed on made ground ?

5.—Show, by sketches, how you would prepare the site for a dwelling-house to be erected on a hill-side, the formation of which is a shaly rock, and which rises from the roadway at a gradient of 1 in 10.

6.—Write a short specification for a foundation on very wet, peaty soil, not less than 10 ft. in depth, and illustrate, with sketches, your suggested mode of construction up to ground floor level, including a basement.

7.—Describe the construction of hollow walls, the ties employed, the distance apart. Sketch a vertical section of a hollow wall with damp course and footings.

8.—What varieties of bricks are used in a building, and for what purpose?

9.—Explain, by sketch, what is meant by headers and stretchers.

10.—What is meant by "bond" applied to construction? Give sketches of the various methods of bonding used for brick walls, and state which is the strongest.

11.—Describe the process of brickmaking. What is the nature of the nuisance frequently caused in the process?

12.—What is the best method of ascertaining the weathering properties of stone?

13.—Under what circumstances is it necessary to cover the site of a building with concrete? and where it is necessary what should be the thickness and composition of the concrete?

14.—Explain the relative sanitary advantages and disadvantages of walls and the following materials: Ordinary brick wall, 9 ins. thick; stone rubble wall, 20 ins. thick; stone-faced hollow wall, 18 ins. thick.

15.—Under what circumstances would you use hollow walls? State how they should be constructed, and give sketches, showing ties and section through head of window-frame.

16.—How near may woodwork be placed from the inside of a flue? Is it necessary to render the outside as well as the inside, and, if so, to what extent?

17.—Describe the conditions that may be expected to lead to dry rot in a dwelling-house.

18.—Describe and illustrate, by sketches, the various ways of building hollow walls; the wall ties used; how the damp course is placed; and what precautions are taken when girders or lintels occur in hollow walls.

19.—Describe the construction of a dry floor for living-room upon a clay soil. Also the construction of a reasonably sound-proof floor for an upper story. Illustrate by sketches.

20.—Give particulars of the various materials most suitable for covering the walls and floors of an infectious diseases hospital. Also a short specification of how they should be used, and state which materials are considered the best.

21.—Draw a plan and section to a scale of 4 ft. to 1 in. of a fire-proof floor calculated to carry 2 cwt. per ft. super, with figured dimensions of the mode of construction, the size of floor to be 24 ft. by 16 ft., and on the first floor.

22.—Give the rules for calculating the transverse strength of beams: (*a*) supported at each end, load applied in the middle; (*b*) supported at each end, load equally distributed; (*c*) fixed at one end, with load applied at other; (*d*) fixed at one end, with load equally distributed.

## CHAPTER XVII.

Principles of calculating areas, cubic space—Interpretation and drawing of plans and sections to scale.

THE yard is the British standard unit of length, subdivided into feet and inches, and multiplied into furlongs and miles. All the different measures in use are derived from this, even the surveyor's chain, which is 22 yds. long (cricket pitch), and being divided into 100 links, each link measures 7.92 ins., so that this apparently odd fraction is based upon the length of a yard. Distance or linear measure is taken in a straight line from point to point, and measured in inches, feet, yards, fathoms, poles, furlongs, or miles, according to the size and the object in view. Measured lengths may be expressed in mixed units, as 3 ft. 6 ins., 2 ft. 4½ ins., or simple fractions as  $\frac{3}{4}$  in. It is useful to know the decimals corresponding to the more common fractions, viz. :—

$\frac{1}{16} = .0625.$	$\frac{5}{16} = .3125.$	$\frac{9}{16} = .5625.$
$\frac{1}{8} = .125$	$\frac{3}{8} = .375.$	$\frac{5}{8} = .625.$
$\frac{3}{16} = .1875.$	$\frac{7}{16} = .4375.$	$\frac{3}{4} = .75.$
$\frac{1}{4} = .25.$	$\frac{1}{2} = .5.$	$\frac{7}{8} = .875.$

The decimal system is the system of tenths, and just as each figure of an ordinary quantity is worth ten times more in each position to the left, so each figure is worth ten times less in each position on the right of a decimal point. A decimal fraction can always be turned into a common or vulgar fraction by putting a line under it, with a 0 below for each figure and a 1 in front. Thus .125 becomes  $\frac{125}{1000}$ , and if this is brought down to its lowest terms by dividing the top and bottom by the same figures it comes down at last to  $\frac{1}{8}$ . Superficial measure, or surface area, of flat surfaces, results from multiplying the length by the breadth. Say 6 ft. 4½ ins. long by 2 ft. 3 ins. wide, turn it

into inches, then  $76.5 \times 27 = 2065.5$  sq. ins., or dividing by 144 (square inches in 1 sq. ft.) = 14.3475 sq. ft. A much better method of working is by duodecimals, where twelfths are used instead of tenths. This is the common method employed by architects and quantity surveyors. The dimensions are stated thus  $\frac{6.4\frac{1}{2}}{2.3}$ , and the result, called squaring the dimensions, is obtained as follows: First multiply  $6.4\frac{1}{2}$  by 2 (of the 2.3) = 12.9; then 3 ins. being the fourth of a foot divide the  $6.4\frac{1}{2}$  by 4, thus 4 into 6 goes 1 and 2 over, put down 1 under the 12; next the 2 over is equal to  $\frac{2}{12}$ , 24 and 4 are 28, 4 into 28 goes 7 times, put 7 under the 9, then the  $\frac{1}{2}$  remaining when divided by 4 is so small that no account is taken of it, and the result of adding the 12.9 and 1.7 together is 14.4, called 14 ft. 4 in., but really 14 ft. and  $\frac{4}{12}$ ths of a foot. The first result given, 14.3475, can be turned into feet and inches thus: The 14 is 14 ft., then multiply the .3475 by 12 = 4.1700, point off the same number of figures and it leaves 4.17 or an exact total of 14 ft.  $\frac{4.17}{100}$  ins. Note the difference between square feet and feet square, 4 sq. ft. would be simply 4 sq. ft., but 4 ft. square would be 4 ft. each way, equal to 16 sq. ft. Suppose the flat surface to be a triangle, the area would be obtained by multiplying the base by half the perpendicular height. If the length of the sides only is given, the method of working is best shown by a formula. Let  $a, b, c$  = the lengths of the sides respectively, and  $s$  = half the sum of the sides,  $A$  = the area of the triangle, then

$$A = \sqrt{s(s-a)(s-b)(s-c)}.$$

Suppose the sides of the triangle to be 3, 4, and 5 ins. long, then

$$s = \frac{3 + 4 + 5}{2} = 6, \quad s - a = 6 - 3 = 3, \quad s - b = 6 - 4 = 2,$$

$$s - c = 6 - 5 = 1,$$

now multiply these together,

$$6 \times 3 \times 2 \times 1 = 36,$$

and take the square root,  $\sqrt{36} = 6$  sq. ins., which is the area of the triangle. Note that a triangle with the sides in the proportion of 3, 4, and 5 always contains a right angle. For the area of a circle we have  $A = \pi r^2$ , where  $\pi$  is a Greek letter

standing for  $3.1416$  or  $\frac{22}{7}$ , the ratio of circumference to diameter of all circles, and  $r$  the radius of the particular circle to be calculated. The area of the segment of a circle is rather difficult to obtain accurately, it is generally sufficient to take it as equal to the base multiplied by two-thirds of the height. For the sloping surface of a cone we have  $A = \frac{1}{2}$  slant height  $\times$  circumference of base. For the surface of a sphere  $A = \pi d^2$ . For a solid figure the unit of volume is a cubic inch, and the total is obtained by multiplying together the length, breadth, and thickness in the same manner as before. In building materials the unit may be a cubic foot, and in excavation a cubic yard. For a cone or pyramid we have volume = area of base  $\times$  one-third perpendicular height. For the frustum of a cone (or cone with the point cut off) like an ordinary bucket,

$$V = \frac{\pi}{12}h(D^2 + d^2 + Dd)$$

giving the result in cubic inches, and dividing this by  $277\frac{1}{2}$  or multiplying by  $.0036$ , the result will be obtained in gallons. The largest size bucket, 15 ins. by 15 ins. by 9 ins., holds  $6\frac{1}{4}$  gallons. An ordinary bucket, 12 ins. by 12 ins. by  $7\frac{1}{2}$  ins., holds  $3\frac{1}{4}$  gallons. A small bucket, 10 ins. by 10 ins. by 6 ins., holds  $1\frac{1}{16}$  gallons. The simplest formula is—

$$\text{Gals.} = \frac{946}{1,000,000}h(D^2 + d^2 + Dd)$$

where  $h$  = height inside in inches,  $D$  = diameter inside at top,  $d$  = diameter inside at bottom. To divide by 1,000,000, point off six figures of the total, thus, ordinary bucket

$$\frac{946}{1,000,000} \times 12(12^2 + 7\frac{1}{2}^2 + 12 \times 7\frac{1}{2}) = 3.294 \text{ gallons.}$$

For a wedge, which is like a roof with gable ends, and also for an ordinary hipped roof with a ridge, as Fig. 102, we have  $V = \frac{1}{6}$  (length of edge or ridge + twice length of back or base)  $\times$  height  $\times$  breadth of base. Thus the volume occupied by a hipped roof, pitch 30 degrees, on a building 40 ft. by 20 ft. will be found thus: For the height consider the cross-section, the slope of 30 degrees from the eaves will, at a distance of 10 ft. (half the breadth), give a height of  $10 \tan 30^\circ = 5.77$  ft. For the length of ridge take  $2 \times 10$  from the

length of building =  $40 - 20 = 20$  ft. Then the volume =  $\frac{1}{6} (20 + 2 \times 40) \times 5.77 \times 20 = 1923\frac{1}{3}$  cub. ft. More briefly, the calculation of volume may be put thus—

$$V = \frac{BH}{6} (3L + B).$$

The net area of the slating will be the length  $\times$  width  $\times$   $\tan \theta = 40 \times 20 \times .577 = 462$  sq. ft. =  $4\frac{5}{8}$  squares of 100 ft. sup.

For a truncated pyramid, such as a heap of stones at the roadside with a flat top, the volume will be the same as for the frustum of a cone, viz.  $V = \frac{1}{3}h(A + a + \sqrt{A \times a})$ , where  $h$  = the vertical height,  $A$  = area of base,  $a$  = area of top.

The volume of a sphere is  $V = \frac{\pi}{6}d^3$ , or  $.5236d^3$ .

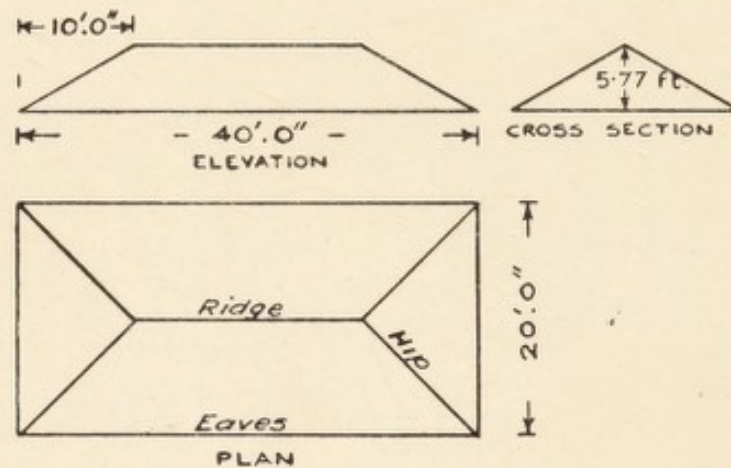

FIG. 102.—General view of hipped roof.

Drawings for practical use are always made "to scale," that is, every part is in proportion to its real shape and dimensions but reduced in size to go on the paper. For buildings we have elevations, plans, and sections, generally all to the same scale,  $\frac{1}{8}$  in. or  $\frac{1}{4}$  in. to 1 ft., the meaning of the terms being too well known to need further description. For drainage work we have plans and sections as the necessary drawings, but there is a difference in the scaling horizontally and vertically. Generally, the plan and horizontal distances on the section will be to a small scale, say 10 ft. to 1 in., or  $\frac{1}{8}$  in. to 1 ft., or on large works  $\frac{1}{2500}$ , the corresponding vertical scales being for the two former either the same as the horizontal or  $\frac{1}{4}$  in. to 1 ft., while the latter will be 10 ft. to 1 in. This is to permit of the falls and gradients being shown more clearly, but care must be taken

in calculating the gradients to allow for the difference of scales. The fraction  $\frac{1}{2500}$  means that the drawing is  $\frac{1}{2500}$  of the natural size, or

$$\frac{5280 \times 12}{2500} = 25.344 \text{ ins. to 1 mile, or } \frac{2500}{12} = 208\frac{1}{3} \text{ ft. to 1 in.}$$

The different views upon drawings should be "projected" one from the other, that is, drawn exactly opposite point for point. This enables them to be understood much more easily. All essential dimensions should be put on in figures and carefully checked, as the specification usually says, "The figured dimensions to be taken in preference to the scale." The expression "reading a plan" merely means studying the drawing until the full meaning of it is realized.

#### EXAMINATION QUESTIONS RELATING TO CHAPTER XVII.

1.—A hipped roof is 40 ft. by 20 ft., with a pitch of 30 degrees; what is the total surface and volume?

2.—Calculate the area of the following figures: (1) a square with a diagonal of 20 ft.; (2) a circle with a diameter of 20 ft.; (3) an equilateral triangle with a base of 20 ft.

3.—The fall of a drain is to be 1 in 40; what difference of level would there be in 75 ft.? Show your working.

4.—A cylinder 4 ft. long is filled with water, the weight of which is 196 lb. What is the diameter of the cylinder?

5.—Calculate, in cubic feet and in gallons, the contents of a well 4 ft. 6 ins. inside diameter and 40 ft. deep, the water level being 8 ft. from the ground level.

6.—Calculate the contents, in gallons, of a circular reservoir, 20 ft. in diameter at the top, 15 ft. diameter at the bottom, and 3 ft. deep, with a brick pier 18 ins. square and 4 ft. high in the centre.

7.—Explain the terms "cubic space" and "superficial area," and give their values for a room measuring 18 ft. long, 14 ft. wide, and 10 ft. high.

8.—The plan of a building is an equal armed cross, the arms 20 ft. wide and 20 ft. projection. The height is 20 ft. to the eaves, and the roof is 45 degrees pitch with gable ends. What is the total cubic contents?

9.—The plan of a site has been drawn to a scale of 20 ft. to 1 in., its area has been measured from the plan by a scale of 16 ft. to 1 in. as 3200 sq. ft.; what is its true area?

10.—An attic room is 20 ft. by 16 ft., the height for half the 16 ft. is 9 ft., and for the other half it slopes down to 5 ft. at the wall. State the cubical contents of the room and the minimum height allowed by any regulations.

11.—What is meant by “quarter scale” on the corner of a drawing? A drain measured 10 ins. long on this drawing and is marked “fall 18 ins.” What will be the gradient?

12.—A flask has the lower part formed as a cone with a base 8 ins. diameter and a height of 6 ins. where it reduces to 1 in. diameter and there joins a cylindrical portion 1 in. diameter and 9 ins. high, all internal dimensions. It weighs 1 lb. Calculate accurately (a) the capacity; (b) the pressure per square inch on the bottom when filled with water; (c) the total internal pressure on base; (d) the external pressure upon support.

13.—A cylinder has a height one-and-a-half times the diameter; what will be the dimensions to contain  $2\frac{1}{2}$  gallons?

14.—Five 1-in. pipes are to discharge into a single pipe equal to the combined cross-section of the 1-in. pipes; what will be the diameter?

15.—A hexagonal room has sides of 10 ft. and a height of 10 ft. What is the total capacity?

✓  
CHAPTER XVIII.

Road construction—General provisions of the Building Acts and By-Laws.

THE essentials in road construction are that there should be a suitable width for the traffic, suitable gradients to reduce the tractive effort and the upkeep of the roads, good drainage so that there may be no settlements, a sufficient thickness to withstand the loads, a good wearing surface that shall be easily cleansed and sufficient camber to throw off the rain. The minimum width of roadway, even in country districts, should be 20 ft., and if a footway on one or both sides can be given also, it will be an advantage. A private road, such as a farm road, with traffic in one direction only may be 10 ft. or 12 ft. wide. A suburban road should not be less than 40 ft. wide, including two 7 ft. footpaths. A main city road may be 60 ft., 80 ft., 100 ft., or 120 ft. wide, according to the traffic. As a rule the gradients follow the existing surface levels, but a rise of 1 ft. vertical to 30 ft. horizontal distance, or 1 in 30, is considered to be the maximum without incurring excessive charges for maintenance. It should be remembered that the tractive force required will increase with the gradient, thus, 1 in 30 would mean that besides the force required on the level, extra force, amounting to  $\frac{1}{30}$  of the whole load, would be required to overcome the gradient.

The under-drainage of a country road is generally by means of agricultural pipes laid diagonally down the gradient, if any, from the centre to ditches at the side, and the surface drainage simply runs off the surface into channels with grips, or narrow trenches, into the same ditches. For a town road the drainage is provided for by giving the surface a camber of  $\frac{3}{8}$  in. per foot as a maximum from the centre to a paved channel against

each footpath kerb, in which road gullies are placed about every 2 to 3 chains. The overflow from these gullies is taken into the sewer below the centre of the road. The height of the curb varies between 3 and 6 ins. for suburban roads, and between 6 and 8 ins. for town roads with motor traffic; the range in each case is required to allow of a fall of 1 in 120 to be given to the channel towards the gullies. The footpath usually falls  $\frac{1}{2}$  in. per foot towards the channel, but  $\frac{1}{4}$  in. is allowed if it be paved. A suburban road may be 6 ins. of hard core, such as broken brick, clinker, or chalk, covered with 4 ins. of flints well rolled in. If there is much heavy traffic it may be of 9 ins. hard core, 2 ins. gravel, and 4 ins. broken granite or macadam. A flint road swept and well tarred, or a road laid with tarred macadam, will last in good condition much longer and be free from dust. If a city road, the foundation may be 9 ins. to 12 ins. of Portland cement concrete covered with  $1\frac{1}{2}$  ins. to 2 ins. asphalt or wood-block paving. Reinforced concrete roads have lately come into use. In towns they are objectionable, because of the frequent opening up for gas, water, and electrical repairs, but for main routes between towns they are in every way advantageous, and many hundreds of miles have been constructed. They consist of, say, 6 ins. P.C. concrete, with wire reinforcement 2 ins. from the bottom. The surface is merely tarred and sanded. In some cases the surface is finished with granolithic.

The Building Acts of 1894 to 1908 are the most important: the following are among the principal provisions: A street for foot traffic only must be paved, and not less than 20 ft. wide. A street for carriage traffic must not be less than 40 ft. wide, including footways. A building must not project beyond the general "building line." There must be a clear space of at least 150 sq. ft. at the rear of every building, it must extend the whole width of the building and be not less than 10 ft. in depth from the building. W.C., ash receptacle, and enclosing walls may be erected on this space if not exceeding 9 ft. high. The height of the building must not cut into a diagonal line drawn at  $62\frac{1}{2}$  degrees from the back boundary. No wall must be more than 16 times its thickness in height. Proportions are laid down for the minimum thickness of dwelling-house and warehouse walls, according to their height and length. A basement storey is one where the floor is more than 4 ft. below ground level, above this it would be called a ground floor

storey. No woodwork may reach nearer than 4 ins. to the centre of a party wall. Parapet walls must extend 18 ins. above the roof gutter, or measured at right angles to the slating. If on "made ground," the site must be covered with 6 ins. of cement concrete. A dwelling-house may not be erected on land below Trinity High Water Mark (12 ft. 6 ins. above Ordnance datum). All water supply and sewerage schemes involving the borrowing of money had to be approved by the Local Government Board; the Ministry of Health has now taken the place of the Local Government Board. The most important Sanitary Acts are the Public Health Act, 1875, the Public Health Act Amendment Act, 1890 (adoptive), the Public Health London Act, 1891, the Public Health Act Amendment Act, 1907. The offensive trades specially regulated are blood boiling, bone boiling, soap boiling, gut scraping, tripe boiling, tallow melting, manure manufacturing, fellmongering, glue-making, fish-frying, fish skin scraping. The emission of black smoke is regulated by the Public Health (S.) Act, 1897. The position of a W.C. is described in the Model By-Laws—one of its sides must be an external wall, a window 2 ft. by 1 ft., exclusive of frame, must open directly into the external air, constant ventilation by at least one air-brick must be provided, it must have a separate cistern or flushing box, it must not lead out of any bedroom, living-room, or place where food is prepared or stored. Under the Factory and Workshops Act, 1901, the Home Office has made regulations as to methods adopted in the construction of buildings, such as scaffoldings, etc., so far as regards safety and health.

#### EXAMINATION QUESTIONS RELATING TO CHAPTER XVIII.

1.—Under what conditions are roads made of various widths; state the widths and the proportion occupied by the footpaths in each case.

2.—What are the relative advantages and disadvantages of footpaths of (a) gravel; (b) tarred gravel; (c) artificial paving; (d) York paving; (e) brick paving?

3.—Describe the manufacture of artificial paving for footpaths.

4.—What camber should be given to the following roads: (a) suburban flint road; (b) urban tar-macadam road; (c) concrete and

asphalt city road; (d) wood-paved road? Give the reason for any difference you may suggest.

5.—How is the level of the footpaths determined in setting out a new road? Sketch the section of a footpath 8 ft. wide with granite curb and channel.

6.—Sketch the section of a reinforced concrete road for heavy suburban traffic.

7.—Describe the various motor vehicles that are used in the watering, cleaning, and repairing of roads.

8.—Explain the reasons for the various heights of the kerbs to the footpaths. Give the maximum and minimum dimensions respectively for city and suburban roads.

9.—What are the essential points to observe in laying a wood block roadway? Discuss the relative merits of hard and soft wood for this purpose.

10.—When a new road is formed in a city suburb it is often found that the entrances to the various premises are at different levels, so that it is difficult to determine the level of the footpaths. Show by sketches the different ways in which this difficulty is overcome.

11.—In developing a new estate for building purposes, how are the lines of intermediate roads determined? Why is such an estate often surrounded by a 2 ft. width of boundary which is not included in the sale of the plots?

12.—State the relative advantages and disadvantages in the use of the various materials employed for road covering. How may some of the disadvantages be obviated?

13.—State how you would proceed to fix the levels to form a new street 40 ft. wide, under the Private Street Works Act, 1892, where the houses were built on one side of the street only. Make a sketch of the cross-section to a scale of  $\frac{1}{4}$  in. to the foot.

14.—Give approximately the resistance per ton or "traction" of a carriage on rails, on a paved road, and on a gravel road.

15.—It is desired to construct an approach road 600 ft. long across a field to a sewage disposal works. At the main road the level is 154.00 and in the fields the levels are 159.00, 156.00, 148.00, 150.00, and 146.00 at 100, 200, 300, 400, and 500 ft. respectively from the road. At the latter point there is a hedge with a ditch 15 ins. deep. Sketch a longitudinal section and typical cross-sections of the roadway, showing clearly the method of construction and the materials you would employ.

16.—What conditions have to be fulfilled before commencing to lay out a new street?

17.—Describe the method of setting out and constructing a new suburban road; give plan and cross-section with dimensions.

18.—Contrast tar-macadam, wood paving, and asphalt for a town road, as regards cleansing, maintenance, and repair.

19.—Draw up a brief set of regulations for the sanitary control of a temporary holiday camp. Your remarks should cover sewage and refuse disposal, and water supply.

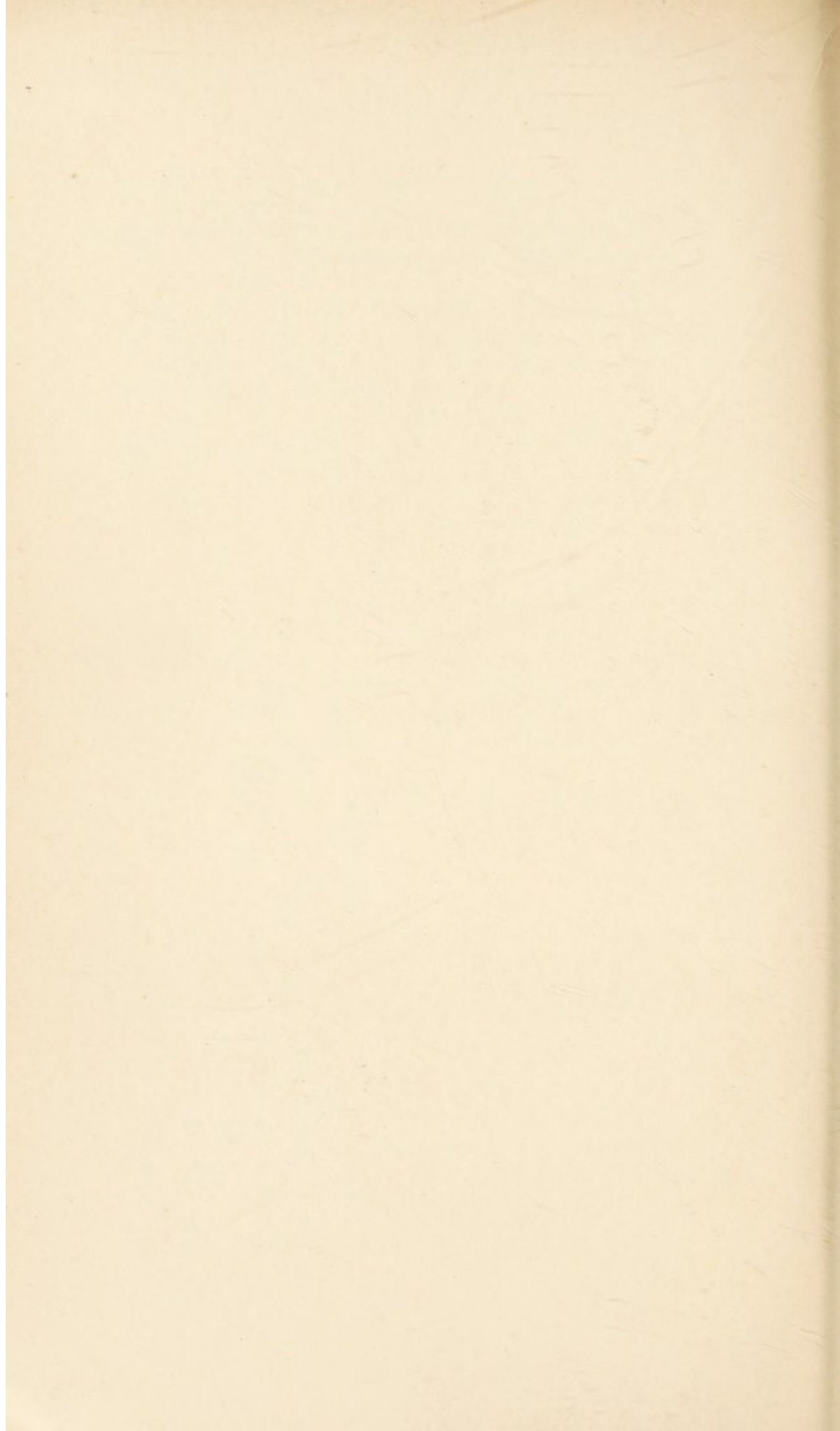

SECTION VII.  
EXAMINATIONS.

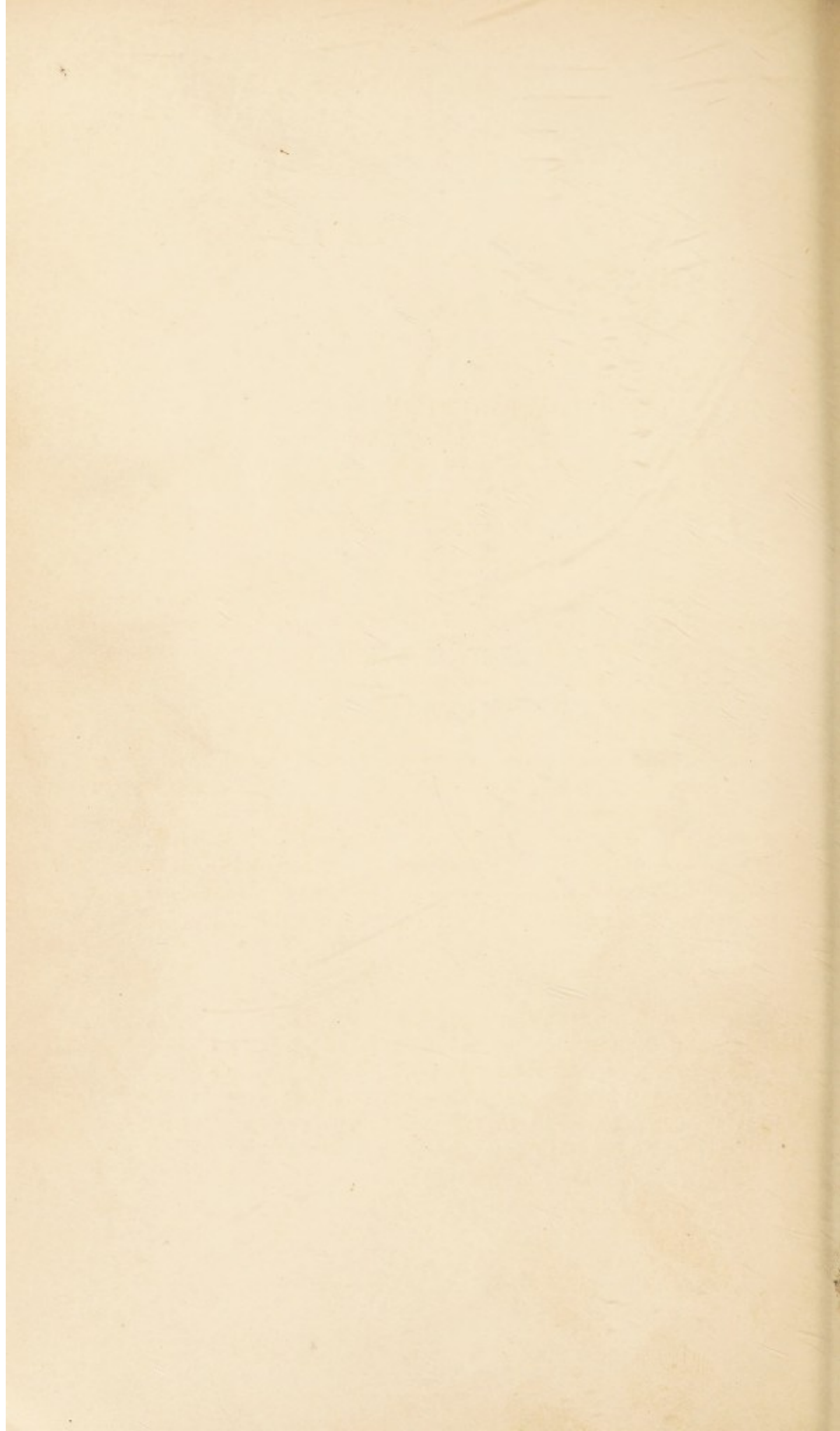

## CHAPTER XIX.

**How to Pass in an Examination.**—There are certain golden rules for candidates. Take your time, do not be excited or nervous. Look through the questions first, and if you are not allowed to answer all of them strike out those you know least about and answer the others in order. Follow carefully the instructions given as to numbering your answers, etc. Keep directly to the requirements of the question; information on other matters will only waste time and annoy the examiner. Be neither too brief nor too diffuse in your answer. Write neatly, and be careful of your spelling. Neatness in sketching, without over-elaboration of details, is time well spent. In a *viva-voce* examination, answer promptly and distinctly. If you do not know the answer say so at once, or if you are doubtful express your doubts. No one person can know everything, but what he does know he should be able to describe intelligently. A confident look is a great asset, especially if accompanied by a confident feeling, but arrogance, impertinence, or frivolity are fatal to success. Remembering the old couplet,

A little nonsense now and then  
Is relished by the wisest men,

it may not be inappropriate to look upon the other side of the subject and point out how candidates fail.

**How to Fail in an Examination.**—Examinations in general are a perennial source of amusement and sorrow to the examiners; amusement at the absurdity of many of the answers, and sorrow that candidates should be so ill-prepared to face the stern realities of the examination room. Schoolboys are not the only ones who perpetrate such howlers as "a Vacuum is where the Pope lives," or "an Artesian well is a well surrounded by Artesians' dwellings." The worked papers at the sanitary examinations, including those for Sanitary Inspectors, are prolific in such rabid statements.

Here are some of the replies about water which have come under the notice of the writer: "There are two kinds of hardness in water, hard and soft." "Hard water is anything over one degree." "One degree of hardness equals one grain per 1000 gallons; 6 to 14 degrees is temporary hardness, 14 and above is permanent hardness." "Hardness indicates more than one degree of carbonate of lime." "Total hardness is hardness that can only be removed by condensation." "The incrustation of water mains is caused by carbonate of soda." "Deep well water is usually purer than shallow well water because most of the impurities settle at the bottom." "An artesian well is a well which is found after boring through two or three stratas." "Hard water may be purified by the Porter-Chalk process." "The way to soften water is to pass the C of the carbonate of soda through a meter and then pass the water through a filter." "Before taking a sample of water for analysis the Winchester quart bottle should be sterilized by boiling." "The impure gas likely to be present in a well is nitrogen. To drive out the gas provide a cupola and a force pump." "The Pasteur Chamberland filter is the best, it consists of two tubes of fine gauze, one within the other." "Materials for filters are lead, *granulated* charcoal and stoneware—not used in conjunction but separate filter of each." "To ascertain the sources of pollution to a well I should have the water analysed." "Water can be softened by filtering and by chemical analysis." One would ascertain if a well was free from dangerous gases "by means of lowering into the well an aneroid barometer, the gas probably would be sulphuric acid or perhaps coal gas or marsh gas." The next was more ambitious, he said, "There are various ways of getting rid of the gas according to the size of the well. For a small well an umbrella may be inverted and dropped down to bottom of well and after staying a few seconds removed rapidly, carried some distance away, and emptied." Q.—You are instructed to inspect and report upon a well, what points would you look to? A.—"I should first see whether it was a surface well or deep well." Q.—How would you do that? A.—"By digging down alongside it." And again: Q.—How would you repair a plug tap? A.—"Put on a new washer." Q.—How would you prevent the water from coming out while you were doing this? A.—"Plug the tap with a cork."

Then as to drains: "Dr. Angus Smith's solution has the

effect of tinning the inside of iron pipes. Iron pipes have one advantage over stoneware, I might even say two, they are longer and having a threaded joint are more easily laid." "The water test varies from ten minutes to some hours. *Phnematic* air may also be applied in testing drains." "Before testing drains you would plug up all the gullies with putty." "Hassall's joint is formed with a ring of *albuminous* substance." A plumber said he would "fill a drain with water for testing by inserting a compo gas pipe through a trap and pouring water through the pipe." "If a drain will stand 40 ft. head with a hydraulic test it is a good drain, but such test I should say was impossible. Under such a test the drain would sweat." "If a drain was stopped up and I was sent to find the cause I would apply the smoke test." One candidate, on being shown an india-rubber drain stopper with brass screw said it was "a bunsen burner." Another said it was a "mica flap ventilator," and then corrected himself by saying, "No, it is a safety valve for a disinfector." "The action of an ordinary siphon is caused by a vacuum and as nature *abohrs* a vacuum something else if possible must take its place."

As to air and ventilation: "A slaughter-house requires about 1000 cub. ft. per cow changed about 4 ft. per hour." "Respiration renders the air impure because of the *michael-organisms* in the breath." "The hygrometrical state of the atmosphere is measured with a barometer." "An aneroid barometer is a mercurial barometer with a special scale." "A standard barometer is corrected for capillarity by a wet and dry bulb thermometer." "Latent heat is the heat employed in cooking vegetables." "If you take a barometer 1000 ft. up a mountain it will fall one degree centigrade." "The building should be thoroughly ventilated by allowing ample means for the admission of fresh air." "The plenum system of ventilation was invented by Rob. Boyle & Son." "The plenum system is a system of natural ventilation." "The window area in a school should be one-tenth of the floor area per child." "The percentage of humidity that should be maintained in a school is 3000 ft." "A bakehouse should be so constructed as to admit light between 11 and 2." Asked how he would take out the cubic contents of a room one candidate said, "I should take them up with the carpets and other things." In reply to a question on the diffusion of gases one man said, "Hydraulic acid gas is a very useful gas and is used for lifting

heavy weights." "The temperature of air is measured by 790 per cent. of oxygen and 290 per cent. of nitrogen."

As regards the materials of sanitary building construction, an equal amount of ignorance prevails: "Plaster of Paris consists chiefly of Keene's cement or vice versa." "The chemical composition of plaster of Paris are these, viz. carbonate of lime, carbonate of magnesia, alumina, water, loss, etc." "Blue bricks are made of clay which has a blue chemical mixed with it so as to give it its colour." "Sharp sand is sand that is angular not rounded." "Stepped flashing is put along the eaves of a roof to keep water out." "Stone should always be taken from its natural bed." "Portland cement should weigh not less than 12 lb. per struck bushel." "To test concrete, take a little out of the heap with a clean trowel and turn it and mix it up, place it on the trowel and reverse the trowel, if the cement adheres to the trowel will be good." "Concrete is spread over a site to economize headroom." "8 lb. lead is not made, 7 lb. lead is  $\frac{3}{8}$  in. thick," said a plumber who had served 7 years to his trade. "White lead is lime mixed with oil." "White lead is made of yellow *ocre* and linseed oil." "Red lead is calcined white lead and stands heat." "Red lead is the same composition as white lead but more colouring matter." "For the bottle test of Portland cement I should use a beer or wine bottle or Winchester quart," and, in reply to a further query, "not a test tube." "A lead soil-pipe tack is 4 ins. by 4 ins., the drips in a lead gutter are 4 ft. apart." "Made ground is composed of foul gases."

The knowledge of physiology and disease, in those branches of sanitary work where it is required, is lamentably at fault: "Small-pox is caused by impurities from the tan yards." "The Pancreas is a station in the Euston Road." "The incubation period of a disease is the time it takes to incubate." "By incubation period is meant this: If you went out and met anyone with an infectious disease you might get an incubation period." The advantage to an inspector to know the incubation period of a disease was "because if he didn't the patient might get up before he could stop him." "If a corpse is without proper lodging or accommodation he can apply to the magistrate for removal to a mortuary." "A pig with *tuberculosis* would be condemned because it would cause tape-worm in man." Q.—Where would you look for signs of tuberculosis in the carcase of an ox? A.—"In the udder."

Q.—How does milk receive impurities? A.—“By abstraction of the fat.” Q.—What are the dangers of a cold bath? A.—“The kidneys become blue and cold.” Q.—What is the difference in appearance between bull and cow beef? A.—“I don't know, but I know the difference between a bull and a cow.” “In a cow-shed provision should be made for the separation of the sexes.” “Pasteurized milk is milk obtained from cows put out to pasture.” “Lymphatic gland is the place where the food goes down.” “Muscle is a hard waxy gristle.” “Bones grow in length by muscular contraction.” “Reflex action is the action of blood through the lungs.” “Sweat blocks up the *spores* of the skin.” “Soap is used for washing because it is an *alkaloid* and dissolves the sebaceous glands.” Q.—Have you seen a sample of food taken for analysis? A.—“Yes, I have seen fish seized.”

The acquaintance with disinfectants is no better: Q.—What do you understand by a deodorant? A.—“A nasty smell.” “Corrosive sublimate, carbolic acid, and mercuric chloride are liquid disinfectants.” “Corrosive sublimate is a liquid, as a disinfectant it would be used in proportion of 1 part to 1000 cub. ft.” Crystals of phenol were recognized by several candidates as “Epsom salts”; permanganate of potash in ordinary purple crystals, small and uniform, became “green copperas”; carbolic acid by smell test was “spirits of salts.” “The stool of a typhoid patient should be lime-washed.” “A room may be disinfected by burning chloride of lime.”

Some of the sanitary science candidates are bad offenders because they are supposed to come from a better educated class: “The cause of wind is the tides.” “A dumpy level consists of a telescope inside of which is a spirit level.” “Ordnance datum is 15 ft. above mean sea level.” “There are two ways of making steel, forging and casting.” “Mechanical efficiency means made efficient by mechanical means.” “You find the velocity of a stream by throwing in an orange and running alongside.” “A surveyor's chain is 66 yds. long.” “Levelling is finding the heights of different parts above one another.”

The above by no means represent all the “howlers” that the writer has come across during his work as an examiner, but they give a fair indication of the answers made by the candidates who do not pass. The majority “cram” for an examination and get at best but a superficial knowledge. The

extreme case was that of a candidate in sanitary science who obtained a total of minus four marks ; he had none for any answer in the written paper or the *viva-voce* examination, but had two marks deducted for bad writing and two for bad spelling. He was well up in formulæ but applied them at random ; for example, being asked how he would measure the quantity of water flowing in a stream he replied : " square the diameter and multiply by  $\cdot 7854$ ." Again, what would be the pressure per square inch due to 10 ft. head of water ? A.—" $\sqrt{2gh}$ ." Apparently he had learnt, parrot-like, all the usual formulæ without their application.

At the Royal Society of Arts Examinations, where over 70,000 papers are worked annually, the candidates seem to be equally unmindful of their best interests. The following paragraphs from the last report are inserted by permission of the Secretary.

#### SOME COMMON FAULTS IN CANDIDATES.

The reports of the examiners on the papers submitted to them are published each year in the pamphlets containing the various examination papers. In many of these may be found much useful criticism which it would well repay both teachers and students to study carefully. Unfortunately it would appear, from the way in which the same lessons have to be repeated year after year, that these reports are not read as attentively as they deserve, if they are read at all. There are several points which the examiners are always trying to emphasize, and of these the following three are the most constantly recurring :—

- (1) A great many candidates fail because they will not, or cannot, read the questions intelligently. If a candidate is asked one question and he answers another, it either means that he does not know the answer to the question set, or worse still, that he is incapable of understanding the meaning of the words used. Teachers would do well to exercise their students frequently in working examination papers in order to ensure that this point is thoroughly drilled into them.

- (2) Many candidates apparently think that any kind of handwriting is good enough for an examination answer. With the best will in the world even an examiner cannot read illegible writing, and if he has great difficulty in making out what a candidate has written he is naturally pre-disposed to punish the malefactor.
- (3) Closely allied to the second point is the question of setting down the answers in a neat and methodical fashion. Some candidates even sprinkle different parts of one answer over several pages. An examiner who is put to the trouble of piecing together these random oddments is more than justified in deducting marks, for if he does not do this, how is he to make a just award to a candidate whose methods are excellent?

What has been said on these three points is, of course, obvious, and it should be quite unnecessary to mention them ; but unfortunately the oft-repeated laments of the examiners show that it is not so.

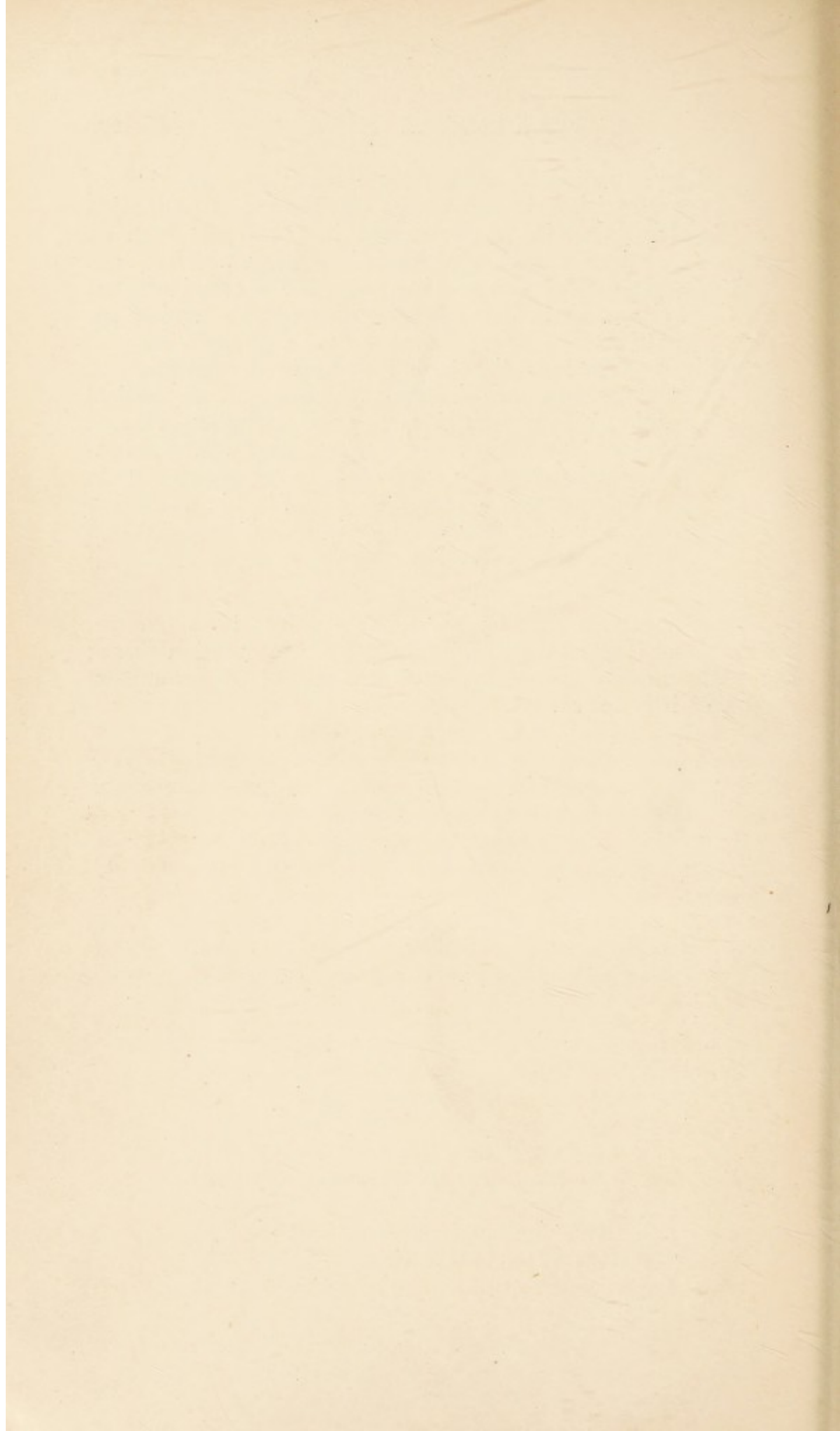

## APPENDIX.

THE ROYAL SANITARY INSTITUTE,  
90 BUCKINGHAM PALACE ROAD, S.W. 1.

**Examination in Sanitary Science as Applied to  
Buildings and Public Works.**

MANY persons who have no intention of becoming sanitary officers have expressed a desire to obtain a certificate from The Royal Sanitary Institute indicating their knowledge of sanitary science, and the Council have arranged a syllabus, which, although not including many technical subjects that an inspector is required to know, is of a higher standard than the inspectors' examination as far as relates to practical sanitation. The examination is arranged so as to be suitable to sanitary engineers, architects, surveyors, foremen of works, builders, and those engaged in allied trades, managers of property, lecturers, and others requiring a good knowledge of sanitary science.

Any person having passed the examination and received the certificate is, by virtue of having such certificate, upon proposal and election as Member of the Institute, called upon to pay only the reduced subscription annually.

This examination was established in 1895, and the following figures show the total number of examinations held, and the number of candidates :—

	Examinations.	Candidates.	Certificates.
To December, 1923 .	511	2317	930

## SYLLABUS OF SUBJECTS.

*It is essential that a Candidate should have a practical as well as a theoretical knowledge of the subjects set out in the Syllabus.*

*Elementary Physics and Chemistry,*

in so far as they apply to sanitary science.

The composition and properties of air and water.

The principles of hydrostatics, hydraulics, and pneumatics. The diffusion and movement of gases and liquids. The velocity and discharge of liquids and gases through pipes and orifices.

Porosity, capillarity, absorptivity, permeability.

Definition of vacuum, action of siphon, principle of suction, the construction of lift, force, and centrifugal pumps, and hydraulic rams.

Production and transmission of heat, and effects of heat on solids, liquids, and gases.

Elementary chemistry.

Meteorological instruments—their construction, adjustment, and reading.

#### *Local Conditions.*

Aspect—elevation. Hill, plain, and valley. Distance from sea. Influence of surrounding objects.

Winds—rainfall—humidity.

Soil and subsoil, and its drainage. Pollutions of soil.

Ground air and ground water and their pollution.

Sanitary precautions as to healthiness of site.

#### *Air, Lighting and Warming.*

Air movements. Sources of pollution.

Principles of ventilation. Air space and quantity required.

Methods of, and appliances for, ventilation.

Ventilation of public buildings, hospitals, schools, factories, dwelling-houses, etc.

“Over-crowding on space” and in buildings.

Air space surrounding buildings. Angle of daylight illumination.

Size and position of windows.

Methods of artificial lighting, advantages and disadvantages.

Open fires, stoves, hot water, steam, hot air.

#### *Water.*

Sources of supply. Gathering grounds. Measuring the flow of water. Impounding, storage, and service reservoirs.

Physical characteristics of various waters.

The solvent effect of certain substances in solution.

Filtration, softening, and other purifying processes.

Requirements and supply of towns, villages, country houses, and cottages. Mains, pipes, fittings, and storage.

Sources of contamination and protective precautions.

*Drainage, Sewerage, and Sanitary Appliances.*

The proper conditions of good drainage. Re-modelling old drainage. The planning and construction of new drains and sewers.

Disposal of surface and rain water.

The principles involved in the various methods of sewage treatment.

The various systems of dealing with house sewage and house refuse.

Advantages and disadvantages of various sanitary appliances.

Inspection and testing of drainage work and appliances.

Disinfecting apparatus and disinfectants.

*Materials and Construction.*

General description of materials used in construction, namely metals, timber, cements, mortars, concrete, stones, bricks and tiles, terra cotta, stoneware, materials for covering roofs, and materials used for preservation and decoration, such as rendering, plaster work, paints, and varnishes; as to their—

Perviousness to moisture, conductivity of heat, facility of working and using, strength, durability, power to withstand fire, purposes for which suitable.

General principles of construction as applying to: Foundations in various soils. Walls; hollow walls, damp course, bond. Floors for basements or cellars, fire-proof partitions. Roofs, covering for same, gutters, hips, valleys. Fire-proof construction.

Principles of calculating areas, cubic space.

Interpretation and drawing of plans and sections to scale.

House and town planning. Road construction.

General provisions of the building acts and by-laws.

## REGULATIONS.

1. Application for examination must be made on the proper form, and must be sent to the office of the Institute 14 days before the date of the examination at which the candidate wishes to present himself.

2. Candidates are required to furnish the Board of Examiners with satisfactory testimonials of recent date as to age and personal character; these should, if possible, be from a clergyman, medical man, or some one holding an official position. Testimonials are returned after the examination.

3. The fee for the examination in Great Britain and Ireland is £5 5s. It should be sent with the application form, or 10s. 6d. on

making application, and the remainder at least one week before the date of examination.

4. The examination occupies a portion of two days. On the first day it consists of two written papers, two hours being allowed for each. On the second day the examination is *viva voce*, with one or more questions to be answered in writing, if required.

5. A certificate of competency, bearing the seal of the Institute, is granted to each successful candidate.

6. A certificate is not granted to any candidate under 21 years of age.

7. Unsuccessful candidates are allowed to present themselves, at intervals of not less than three months, a second and third time within two years of their first application on payment of half the fee set out in the regulations for the examination at which he desires to sit; but in every case the candidate must make application on the prescribed form previous to presenting himself.

\* Candidates are recommended to visit practically all the following :—

Waterworks, reservoirs, filtration beds, mechanical filtration plants.—Water-softening plant.

Public and domestic buildings in all stages of their construction.—Systems of heating, lighting, and ventilation of public buildings, hospitals, schools, factories, laundries, baths, and wash-houses, domestic buildings.—House drainage.

Sewer construction and sewage purification and disposal works.

Refuse disposal works. Disinfecting plant.

Road construction.

The inspections must have been of such a character as to enable candidates to get a clear and thorough understanding of the principles of working and construction, of materials, appliances, apparatus, and workmanship, and of the scientific and practical principles on which operations and processes are founded.

NOTE.—A course of lectures and practical demonstrations in Sanitary Science is given twice in the year at the Royal Sanitary Institute. A Syllabus may be obtained on application to the Secretary.

## INDEX.

- A**BSOLUTE zero, 23.  
 Absorptivity, 14.  
 Accelerating force of gravity, 4.  
 Acetylene gas, 63.  
 Acid, 30.  
 Activated sludge, 127.  
 Adhesion, 14.  
 Adiabatic, 9.  
 Agricultural pipes, 46.  
 Air allowance for factories, etc., 54.  
 — composition of, 9.  
 — inlets and outlets, 55.  
 — lock, 7.  
 — required for ventilation, 54.  
 — space round buildings, 60.  
 — velocity in ventilation, 55.  
 — weight of, 36.  
 Alkali, 30.  
 Analysis, 28.  
 — of water, 31.  
 Anemometer, 37.  
 Aneroid barometer, 39.  
 Angle of illumination, 61.  
 Anti-cyclone, 36.  
 Antiseptics, 132.  
 Anti-siphonage pipes, 101.  
 Area of circle, 4.  
 Arnot ventilator, 56.  
 Artesian wells, 88.  
 Artificial lighting, 62.  
 Aspect, definition of, 45.  
 Atmospheric pressure, 4.  
 Atoms, 10, 28, 30.
- B**ALL-COCK in section, 95.  
 Barometer, 36.  
 Base, chemical, 30.  
 Beaufort wind scale, 38.  
 B. coli, 87.  
 Biological treatment of sewage, 126.  
 Blown joint, 119.  
 Bonding bricks, 150.  
 Boning-rod, 109.  
 Bower-Barff process, 93.  
 Boyle's law, 6.  
 Brass, 139.  
 Bricks, 142.
- British Sanitary Company's earth-closet, 116.  
 — thermal unit, 24.  
 Broad irrigation, 124.  
 Bronze, 139.  
 Bucket and plunger pump, 17.  
 Bunsen burner, 68.  
 Buoyancy, 5.
- C**ALCULATING areas, 159.  
 Calorifier, 73.  
 Candle-power, 63.  
 Capillarity, 14.  
 Carbon dioxide, 9, 53.  
 — — in air, 53.  
 — monoxide, 53.  
 Cast-iron, description of, 137.  
 Cavitation in pumps, 17.  
 Cement mortar, 140.  
 Centigrade thermometer, 23.  
 Centrifugal pump, 17.  
 Cesspool, 117.  
 — position of, 47.  
 Charles' law, 10.  
 Chemical element, 28.  
 — compound, 28.  
 — symbols and formulæ, 28.  
 — transformations, 29.  
 Cisterns, 94.  
 Clarke's scale of hardness, 86.  
 Coal gas, composition of, 62.  
 Coating pipes, 93.  
 Coefficient of contraction, 4.  
 — — discharge, 4.  
 — — velocity, 4.  
 Cohesion, 14.  
 Colloidal, 30.  
 Composition, Dr. Angus Smith's, 93.  
 Concrete, 140.  
 Conduction, 22.  
 Cone of depression, 88.  
 Contact beds, 129.  
 Convection, 22.  
 Copper, 138.  
 — bit joint, 119.  
 Crystalline, 30.

Cubic space allowed, 54.  
 Cutters and rubbers, 143.  
 Cyclone, 36.  
 Cylinder system of hot water, 68.

**D**AM, earthen, 83.  
 — masonry, 83.  
 Damp-proof course, 150.  
 Day's waste water-closet, 117.  
 Death rate, 133.  
 Decimals and fractions, 159.  
 Deep wells, 87.  
 Deodorants, 132.  
 Depth of well, to find, 88.  
 Dew, 24.  
 Dibden's slate bed, 129.  
 Diffusion of gases, 9.  
 Disconnecting chamber, 102.  
 Diseases, water-borne, 87.  
 Disinfecting, 131.  
 Disinfector station, 131.  
 Disinfectors, 131.  
 Domestic filters, 84.  
 Double-acting pump, 17.  
 Doulton's pipe joint, 110.  
 Drain, fall in, 8.  
 — velocity of flow in, 8.  
 Drainage system, a good, 101.  
 Drop system of heating, 71.  
 Dry bulb thermometer, 33.  
 — rot, 150.  
 Duckett's slop water-closet, 117.  
 Dustbins, 129.

**E**ARTH-closets, 115.  
 Earthen dam, 83.  
 Electrolysis, 31.  
 Elm, 140.  
 Expansion of gases, 10.  
 Expectation of life, 133.  
 Explosive mixture of gas, 62.

**F**AHRENHEIT thermometer, 23.  
 Fall of drains, 103.  
 Farmiloe's waste-preventer cistern, 115.  
 Filters, 84.  
 Fir, description of, 139.  
 Fire-bricks, 143.  
 — hydrant, 95.  
 — resisting construction, 153.  
 Flanged joint, plumber's, 119.  
 Flueless gas stoves, 68.  
 Flushing cistern, Field's, 105.  
 Foot-candle, 63.  
 Fortin barometer, 39.  
 Foundations, depth of, 149.  
 Friction due to bends, 6.

**G**ALLONS in cubic foot, 3.  
 Galmins, 5.  
 Gas, composition of, 62.  
 — fires, 67.  
 — flow in pipes, 10.  
 Gases, density of, 9.  
 — expansion of, 10.  
 Gauging weir, 83.  
 Glazed bricks, 143.  
 Granite, 142.  
 Grease trap, 102.  
 Gulf stream, 35.  
 Gunmetal, 139.  
 Gutters, 153.

**H**ARDNESS, Clarke's scale of, 86.  
 — natural scale of, 86.  
 Hassall's pipe joint, 110.  
 Head required for given discharge, 5.  
 Heat, 22.  
 — contraction by, 23.  
 — expansion by, 23.  
 — and temperature, difference between, 25.  
 High-pressure hot-water system, 71.  
 Horsfall's refuse destructor, 129.  
 Hot-water pipes, 68-73.  
 House refuse, 129.  
 Humidity of air, 33, 34.  
 Hydraulic gradient, 6.  
 — mean depth, 8.  
 — ram, 18.  
 Hydraulics, 3.  
 Hydrostatics, 3.

**I**CE, specific gravity of, 3.  
 — weight of, 3.  
 Illumination required, 63.  
 Impounding reservoir, 81.  
 Incubation periods, 132.  
 Infectious diseases, 133.  
 Insecticide, 132.  
 Inspection of drains, 117.  
 Inverted siphon, 15.  
 Iron rust, 29.  
 Isobars, 36.  
 Isothermal, 9.

**K**EENE'S cement, 140.

**L**AND drainage, 46.  
 Latent heat, 24.  
 Lead, 138.  
 — pipes, weight of, 120.  
 Lift pump, 15.  
 Limestones, 142.  
 Local conditions, 45.

Long hopper closet, 113.  
Low-pressure hot-water system, 68.

**M**AGNETIC variation, 45.  
Malleable cast-iron, 138.  
Manure heaps, 47.  
Masonry dam, 83.  
Matter, properties of, 30.  
Maximum and minimum thermometers, 33.  
Measuring notch, 82.  
Mechanical equivalent of heat, 24.  
Meldrum's refuse destructor, 129.  
Metals used in construction, 137.  
Meteorological stations, 33.  
Meteorology, 33.  
Model By-laws, 167.  
Molecules, 10.  
Mortar, 140.  
Motion, molar and molecular, 22.  
Moule's earth-closet, 115.

**N**ATURAL scale of hardness, 86.

**O**AK, 140.  
Offensive trades, 167.  
One-pipe drop system, 72.  
Open fires, 67.  
Ordnance bench marks, 149.  
— datum, 149.  
Over-crowding on space, 55-60.

**P**AINT for ironwork, 145.  
Painting woodwork, 144.  
Paints, 144.  
Pan closet, 113.  
Patternmaker's pine, 140.  
Pegging-out excavations, 149.  
Perflation, 54.  
Permutit process, 85.  
Petrolised-air gas, 63.  
Photometers, 64.  
Pipe joints, 93, 94, 110.  
Pipes, capacity of, 4.  
— relative discharge of, 3, 4, 5.  
— under building, 109.  
Pitch pine, 140.  
Place bricks, 143.  
Planning a sewerage scheme, 104.  
Plenum system, 68.  
Plumber's solder, 139.  
— wiped joint, 139.  
Plunger pump, 16.  
Pneumatics, 9.  
Porosity, 14.  
Portland cement, 140.  
Precipitation, 30.

Pressure due to head, 3.  
— filters, 84.  
Prevailing winds, 38.  
Products of combustion, 68.  
Properties of matter, 30.  
Prospect, definition of, 45.  
Pumps, 15.  
Purification of water, 87.

**Q**UANTITY of water required, 92.  
Quicklime, 29.

**R**ADIANT matter, 30.  
Radiation, 22.  
Radiators, 69.  
Rainfall collecting, 79.  
— to acre, 35.  
Rain gauge, 35.  
Rain-water filter, 82.  
— pipes, 101.  
— separator, 79.  
Reciprocating pumps, 15-17.  
Refuse destructor, 129.  
Relative humidity, 34.  
Rendering, 143.  
Road construction, 165.  
Roberts' rain-water separator, 79.  
Roman cement, 140.

**S**ALT, 30.  
Sand filter, 84.  
Sandstones, 142.  
Sanitary accommodation required, 103, 104.  
Schools, sanitary accommodation for, 104.  
Screw-down bib-cock, 120.  
Sea water, weight of 3.  
Sewage disposal works, 125.  
— effluent, 127.  
— filter beds, 129.  
— purification, 124.  
Sheringham ventilator, 56.  
Shone ejector, 106.  
Sight-rails, 109.  
Siphon, 15.  
Size of drains, 103, 109.  
Slaking lime, 29.  
Slate, 142.  
Smoke observations, 130.  
— scale, 130.  
Soap solution, 86.  
Soil pipes, 101.  
Solar spectrum, 62.  
Solders, varieties of, 139.  
Specific gravity, 3.  
— heat, 24.  
Spruce, 140.  
Stainless steel, 138.

Standard candle, 63.  
 — oval sewer, 104.  
 — soap solution, 86.  
 Stanford's pipe joint, 110.  
 Steam, density of, 9.  
 Steel, 137.  
 Stephenson thermometer screen, 33.  
 Stepped flashing, 155.  
 Sterilizing water, 87.  
 Stock bricks, 143.  
 Storage reservoir, 81.  
 Stoves, closed, 68.  
 Stream, velocity of, 8.  
 Subsoil contamination, 47.  
 Suction, depth of, 4.  
 — pump, 15.  
 Sunshine recorder, 35.  
 Surface tension, 14.  
 — wells, 87.

**T**ANK system for hot water, 68.  
 Teak, 140.  
 Temperature, 10, 25.  
 — of hot-water apparatus, 73.  
 — — mixtures, 25.  
 Testing drains, 118.  
 Therm, 24.  
 Thermal capacity, 24.  
 Thermometers, 23, 33.  
 Tiles, 143.  
 Timbering trenches, 107.  
 Time to empty tank, 4.  
 — — fill tank, 5.  
 Tinmen's solder, 139.  
 Tobin tubes, 56.  
 Torricelli's theorem, 4.  
 Trees, effect of, 48.  
 Turning chamber, 101.  
 Two-pipe system, 70, 71.

**U**NHEALTHY situations, 148.  
 Upland gathering grounds, 81.

**V**ACUUM, 14.  
 — ventilation, 68.  
 Valve closet, 114.  
 Vapour, 9.  
 Vena contracta, 4.

Velocity of flow in drain, 8.  
 — — an open stream, 8.  
 — up chimney, 55.  
 Vernier, 39.

**W**ARMING by hot air, 68, 74.  
 — by hot water, 68, 73.  
 — — steam, 74.  
 Wash-down closet, 113.  
 Wash-out closet, 113.  
 Waste-preventer cisterns, 96, 115.  
 Water-borne diseases, 87.  
 — composition of, 3, 31.  
 — for fire extinguishing, 92.  
 — impurities in, 85.  
 — incompressibility of, 87.  
 — maximum density of, 23.  
 — natural velocity of, 9.  
 — pressure, 3.  
 — supply, sources of, 79.  
 — taking samples of, for analysis, 31.  
 — vapour, weight of, 9.  
 — weight of, 3.  
 Watershed, 81.  
 W.C., position of, 167.  
 Weight of air, 36.  
 — — lead pipes, 120.  
 Wells, 88.  
 — position of, 47.  
 Wet bulb thermometer, 33.  
 Winchester quart, 31.  
 Wind, cause of, 55.  
 — mean velocity of, 37.  
 — pressure due to velocity, 37.  
 Window area, 55, 63.  
 Windstar, 38.  
 Wiped joint, 119.  
 Wired glass, 153.  
 Workshops, sanitary accommodation for, 103.  
 Wrought-iron, 137.

**Y**IELD of well, to find, 89.

**Z**INC, 138.





