

Photo-micrography / by Edmund J. Spitta.

Contributors

Spitta, Edmund J. 1853-1921.

Publication/Creation

London : Scientific Press, 1899.

Persistent URL

<https://wellcomecollection.org/works/e554adcc>

License and attribution

This work has been identified as being free of known restrictions under copyright law, including all related and neighbouring rights and is being made available under the Creative Commons, Public Domain Mark.

You can copy, modify, distribute and perform the work, even for commercial purposes, without asking permission.

**wellcome
collection**

Wellcome Collection
183 Euston Road
London NW1 2BE UK
T +44 (0)20 7611 8722
E library@wellcomecollection.org
<https://wellcomecollection.org>

PHOTO-MICROGRAPHY

741

EDMUND J. SPITTA

BECK'S NEW

"BRITISH
STUDENTS"
MICROSCOPES
IN
FOUR MODELS.

ABSOLUTELY RIGID IN
EVERY POSITION.

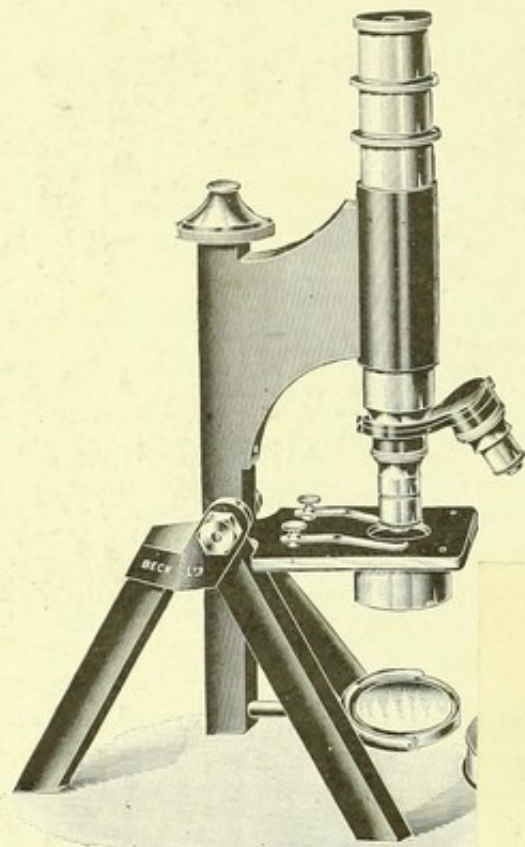

No. 54.—STAND AND MAHOGANY
£2 11s. 6d.

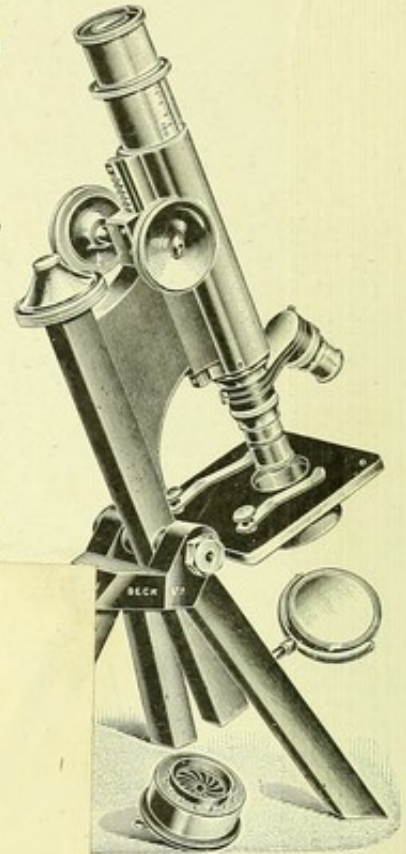

STAND AND MAHOGANY CASE,
£3 12s. 6d.



ASE,

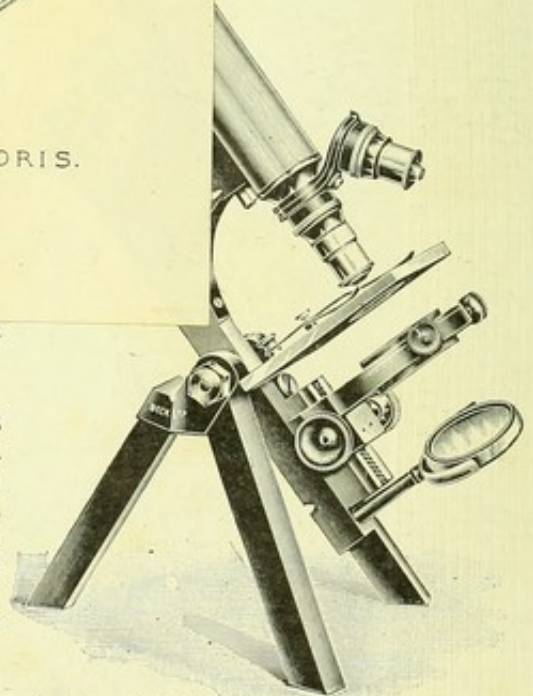

No. 57.—STAND AND MAHOGANY CASE,
£5 12s. 6d.

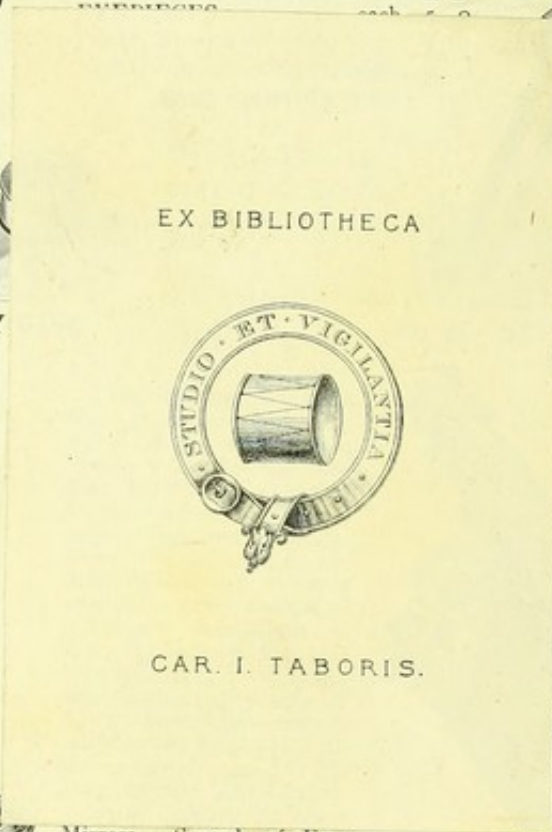

EX BIBLIOTHECA



CAR. I. TABORIS.

Mirrors. Spread of Feet
7 inches.

FULL CATALOGUES
of our various Microscopes
and Apparatus will be
posted free on application,
as it is impossible to
include descriptions of
our other THIRTY
MODELS in a one-page
advertisement.



22102023733

td., 68 CORNHILL, LONDON, E.C.

X 53881

Med
K4110

BRIN'S OXYGEN

For Limelight, Medical, Metallurgical, and other purposes.

OXYGEN of guaranteed purity supplied in Cylinders of the best British manufacture and complying with all the established Trade and Railway Regulations.

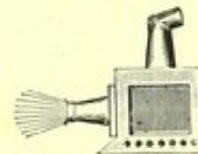

REGISTERED TRADE MARK.

THE Public are respectfully informed that all Cylinders which are filled by the undermentioned Companies (whether their own or their customers') are labelled with their Trade Mark. The label guarantees the purity of the Gas, and is a further guarantee that the Cylinder has been tested and proved sound in every respect by the Company which has filled it. Customers are requested to see that the Cylinders supplied to them bear this label, which is also stamped with the date on which the Cylinder was filled.

The Works of the Companies are open during business hours to customers, who are at liberty to inspect the process of manufacturing Oxygen, and to witness their own Cylinders being tested and filled.

Price Lists of Gases, Cylinders, and all Accessories can be obtained from the Companies' accredited agents, or will be sent post free on application.

REVISED GENERAL PRICE LIST.

| CYLINDERS. | | | | | | |
|-------------------|--|--|---|-------------------------------------|--------------------------------|------------------------------------|
| Type of Cylinder. | Cubic contents in feet at a pressure of 120 Atmospheres. | Approximate external diameter in inches. | Approximate length over all in inches, including valve. | Approximate weight in lbs. (empty). | Price of Cylinders with valve. | Rent per week after first 14 days. |
| | | | | | s. d. | s. d. |
| Seamless | 6 | 4 | 14 | 10 | 26 6 | 1 3 |
| Ditto | 10 | 4 | 19 | 13 | 28 0 | |
| Ditto | 12 | 4 | 23 | 15 | 29 6 | |
| Ditto | 15 | 4 | 27 | 18 | 31 0 | |
| Ditto | 20 | 4 | 35 | 23 | 33 0 | 1 6 |
| Ditto | 40 | 5½ | 36 | 43 | 49 6 | |
| Ditto | 60 | 5½ | 50 | 65 | 59 6 | |
| Ditto | 60 | 7 | 32 | 66 | 68 0 | |
| Lap-welded | 60 | 5½ | 52 | 67 | 59 6 | 2 0 |
| Seamless | 80 | 7 | 41 | 85 | 79 0 | |
| Lap-welded | 80 | 5½ | 68 | 85 | 64 0 | |
| Seamless | 100 | 7 | 49 | 103 | 93 0 | |
| Lap-welded | 100 | 5½ | 82 | 103 | 71 6 | 2 6 |

* The 7-inch Cylinders are only supplied in the solid-drawn seamless type. Larger Cylinders of all types can be supplied to order.

COMPRESSED GASES.

| OXYGEN. | | COAL GAS. | | HYDROGEN. |
|--|---|---|--|-----------|
| Price per Cubic Foot. | | Price per Cubic Foot. | | |
| In the Company's Cylinders. | In a Customer's own Cylinders. | In the Company's Cylinders. | In a Customer's own Cylinders. | |
| Quantities of less than 20 feet, 4d. | Quantities of less than 20 feet, 3d. | Quantities of less than 20 feet, 3½d. | Quantities of less than 20 feet, 2½d. | |
| Quantities of 20 feet and less than 60 feet, 3d. | Quantities of 20 feet and less than 60 feet, 2½d. | Quantities of 20 feet and less than 60 feet, 2½d. | Quantities of 20 feet and less than 60 feet, 2d. | |
| Quantities of 60 feet and upwards, 2½d. | Quantities of 60 feet and upwards, 2d. | Quantities of 60 feet and upwards, 2d. | Quantities of 60 feet and upwards, 1½d. | |

Special Terms to the Trade. Gas in quantities of 20 ft. and upwards is delivered free within 5 miles of Charing Cross.

Addresses { BRIN'S OXYGEN COMPANY, Limited, 34 Victoria Street, WESTMINSTER, S.W.
WORKS; 69 Horseferry Road, WESTMINSTER, S.W.
MANCHESTER OXYGEN COMPANY, Limited, Great Marlborough Street, MANCHESTER.
BIRMINGHAM OXYGEN COMPANY, Limited, Sattley Works, BIRMINGHAM.

PHOTO-MICROGRAPHY

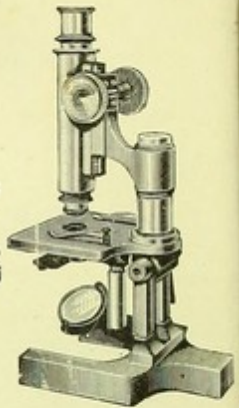
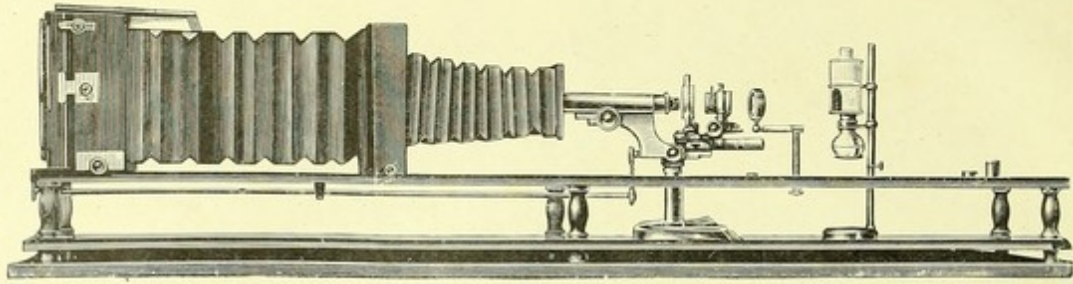
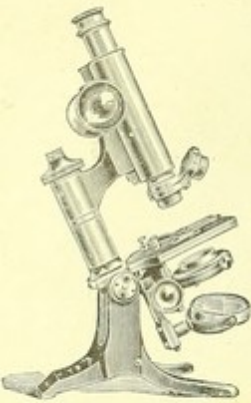

GOLD MEDALS AND HIGHEST AWARDS.

London, 1851. Paris, 1867. London, 1862. Philadelphia, 1876. Paris, 1878.
Antwerp, 1878. Inventions Exhibition, 1885. Sydney, 1879.
Grand Prix and Gold Medal Paris, Exposition Universelle, 1889.
Kingston, Jamaica, 1891. Chicago, 1893, &c. &c.
Grand Prix Diploma of Honour, and Gold, Silver, and Bronze Medals, Brussels, 1897.

ROSS, LIMITED,
Manufacturing Opticians.



CATALOGUE No. 1

CONTAINS FULL PARTICULARS OF

ROSS' Portrait and View Lenses for Amateur and Professional Photographers.
ROSS' ZEISS Anastigmats, including the CONVERTIBLE ANASTIGMATS and NEW PLANAR LENSES.
ROSS-GOERZ' Double Anastigmats.

ROSS' Field and Studio Cameras and Accessories.
ROSS' Process Cameras and Reversing Prisms and Mirrors, &c.
ROSS' Science, Projection, and Enlarging Lanterns.

And several important new series of
LENSES, CAMERAS, LANTERNS, &c. &c.

CATALOGUE No. 2

CONTAINS ILLUSTRATIONS AND PRICES OF

ROSS' Microscopes, Objectives, and Micro-Apparatus.
ROSS' Telescopes, for Sportsmen and Naval and Military Officers.
ROSS' New Series Binocular Glasses and Stereo Telescopes.

ROSS' New Series Opera Glasses.
ROSS' Mercurial and Aneroid Barometers, Thermometers, &c.
ROSS' Sextants, Compasses, Pedometers.
ROSS' Surveying and Drawing Instruments.
ROSS' Spectacles and Eyeglasses, &c.

Including several novel and improved designs in
MICROSCOPES, BINOCULAR GLASSES, BAROMETERS, EYEGLASSES, &c.

Either or both of the above Catalogues will be Forwarded on Application.

ROSS, LTD., Manufacturing Opticians, **LONDON, W.**

And 31 COCKSPUR STREET, CHARING CROSS, S.W.

Established 1830.

Telegraphic Address—"ROSSANO, LONDON."

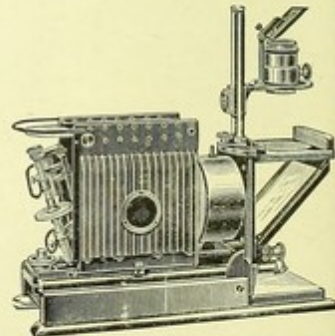
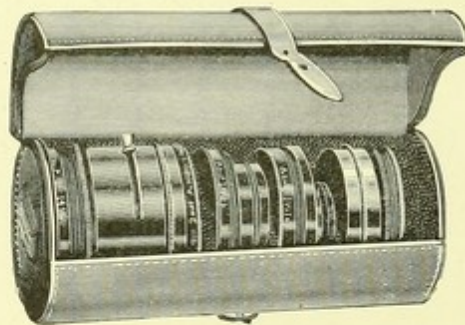
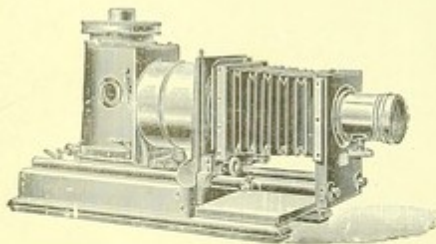
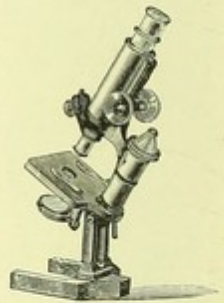



Digitized by the Internet Archive
in 2016

<https://archive.org/details/b28104572>

FRONTISPIECE

(The negatives and reproductions are untouched)

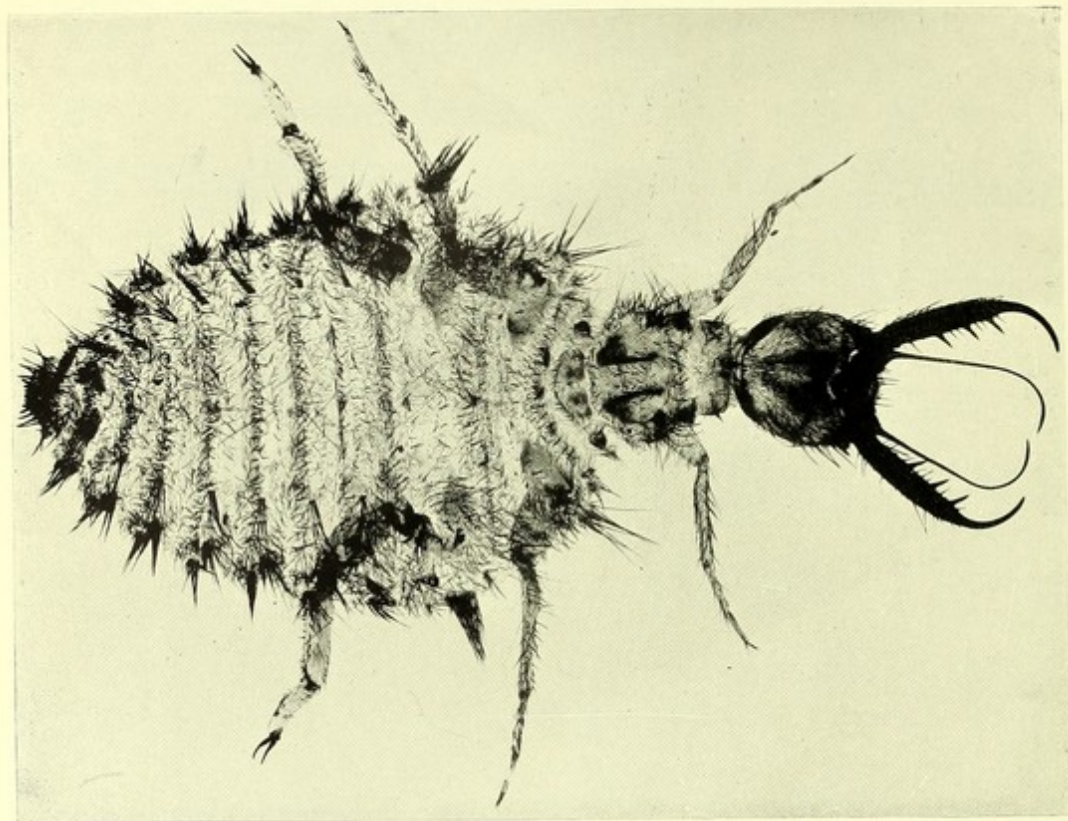

Fig. 1

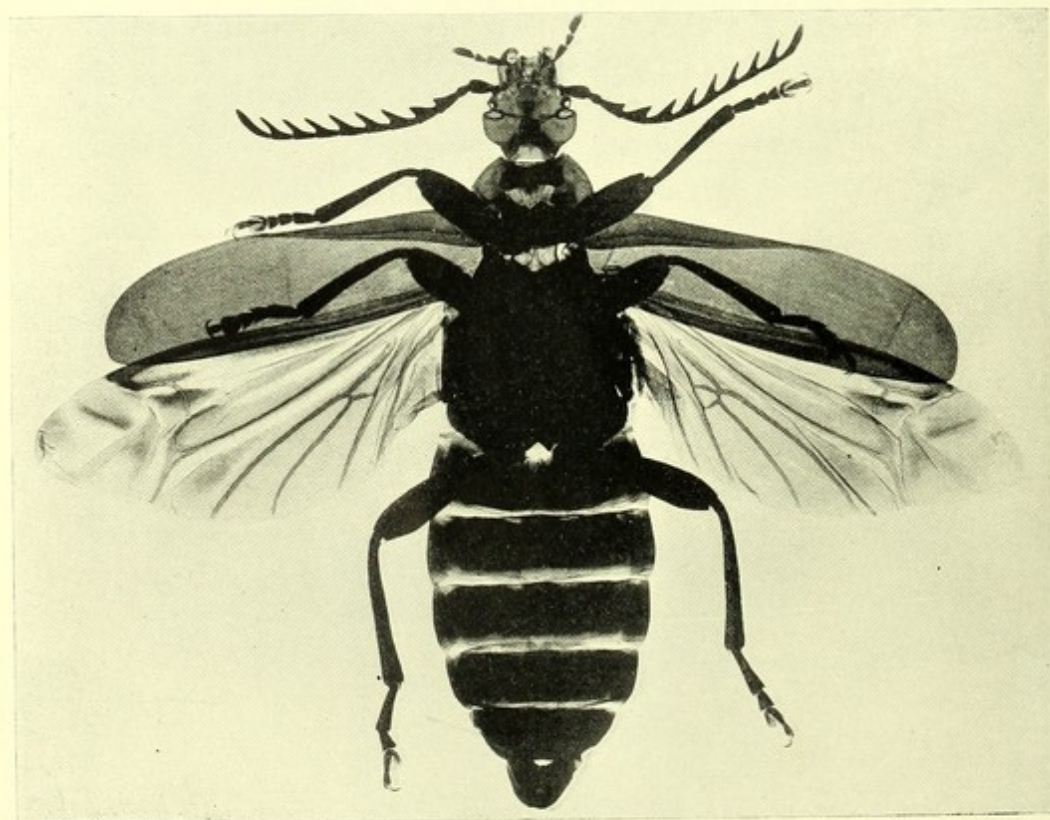

Fig. 2

Blocks by A. E. DENT & Co.

E. & H. SPITTA, Photos.

Fig. 1. LARVA OF ANT LION. Photographed with Zeiss "Planar" 50 mm. focus X 9 at F/22
Fig. 2. CARDINAL BEETLE. Photographed with Ross-Zeiss "Planar" 83 mm. focus X 5 at F/22

PHOTO - MICROGRAPHY

BY

EDMUND J. SPITTA

L.R.C.P. LOND., M.R.C.S. ENG., F.R.A.S.

FORMERLY DEMONSTRATOR OF ANATOMY ST. GEORGE'S HOSPITAL MEDICAL SCHOOL

JOINT AUTHOR "AN ATLAS OF BACTERIOLOGY"

WITH FORTY-ONE HALF-TONE REPRODUCTIONS

FROM ORIGINAL NEGATIVES

AND SIXTY-THREE TEXT ILLUSTRATIONS

LONDON

THE SCIENTIFIC PRESS, LIMITED

28 & 29 SOUTHAMPTON STREET, STRAND

1899

2005 698

| | |
|-------------------------------|----------|
| WELLCOME INSTITUTE LIBRARY | |
| Coll. | we!MOmec |
| Call | |
| No. | QH |
| | |
| | |

Printed by BALLANTYNE, HANSON & Co.
At the Ballantyne Press

P R E F A C E

OWING to the more complete knowledge of the subject gained by the experience of years, and perhaps in a measure to the advent of the perfected dry plate, Photography is being rapidly pressed into use to an extent hitherto little dreamed of. In point of fact, it may be said to have started in times past as an interesting *amusement*, but has now become an absolutely scientific and commercial *necessity*. Indeed, if we look around, we shall readily recognise this to be true, for there is scarcely any science nowadays that does not in some way seek its aid.

But it is of quite recent years that book illustrations of the highest order have been made by this method. Fine hand drawings of objects as seen in the microscope, for example, used to be all in demand, but now Photo-Micrography has stepped in their place, and pictures are produced with an accuracy hitherto unknown. They leave, too—which is a great advantage—no doubt in the reader's mind as to the accuracy of the final result, for even the most captious critic is unable to state his belief that some of the details have been produced by the imagination of the artist, or by an exaggerated conception of an over-enthusiastic draughtsman.

But, like almost any art or science which reaches to a high degree of perfection, Photo-Micrography cannot be learnt in a moment, for it requires both knowledge and patience, practice and skill, to carry it out successfully.

It is to help those commencing the subject, and assist others who may be anxious to achieve the highest results, that this little book has been written. It consists, to a certain extent, of a collection of articles written at the request of the Proprietors of the *Pharmaceutical Journal*, and the Author desires to express his thanks to them, not only for their kindness in allowing him to reproduce the subject-matter in book form, but also for granting the Publishers of this work a free use of all the blocks and photographs which they had the kindness to reproduce as plates in the articles to which reference has been made.

The work, although entirely original—there being no “paste and scissors” in it—does not claim to be an exhaustive treatise on the subject, or pretend to be of classical importance. It has no pretensions of this kind whatever, but purports only to be an account of the experience of the writer, extending over many years, in most if not all departments of the subject. If any novelty can possibly be found it lies in the fact that not only are exact details given as to how most types of test objects can be photographed, but illustrations of the same are actually appended in the Frontispiece and Plates. As so large an amount of space, therefore, is occupied by Photo-Micrography *practically* considered and explained, so the Author has been compelled to his regret, by the limits of space, to omit all reference to the often better executed work of fellow-workers in the subject, and the reader must excuse, on the same grounds, the entire omission of all matters bibliographical or of an etiological nature.

Being only a book on Photo-Micrography and *not* on the microscope, so all theory, too, is purposely omitted, save so much as is necessary to render the text the more intelligible.

Notwithstanding the many “shortcomings” to be found, it is feared, by the critic, and the expression sometimes of opinion which may be given too dogmatically, perhaps, upon definite topics, the writer hopes the end may justify the means, and that, even if fellow-workers of less experience may not derive the benefit he hopes they may in perusing the chapters of this book, some may perchance be induced thereby to take up this interesting subject, one so particularly of use to the doctor, student, and the advanced chemist.

The reproductions throughout the whole work have been entirely made by Messrs. Dent & Co., art reproducers, Bromell’s Road, Clapham, and the Author is desirous of recording his thanks individually to Mr. A. Dent, of the firm, for the amount of care and patience he has so unsparingly bestowed upon them.

This Preface must not be allowed to conclude without the writer adequately expressing his obligations to the several firms who have so liberally allowed him the use of blocks, some taken *especially for this work*; and, not least because last, his thanks to his son, Mr. Harold Spitta, for his very great and continued assistance in all departments of the work, whether in producing the original photo-micrographs or in passing the sheets through the press.

EDMUND J. SPITTA.

CONTENTS

| CHAP. | PAGE |
|--|------|
| INTRODUCTION | 1 |
| I. ILLUMINANTS | 2 |
| II. LOW-POWER WORK | 13 |
| III. MEDIUM-POWER PHOTO-MICROGRAPHY—CAMERA AND ACCESSORIES . | 47 |
| IV. THE MICROSCOPE, LENSES, AND EYE-PIECES USED IN MEDIUM- AND HIGH-POWER WORK | 59 |
| V. THE SUBSTAGE AND AUXILIARY CONDENSERS, AND OTHER MATTERS OF IMPORTANCE FOR BOTH MEDIUM- AND HIGH-POWER PHOTO- MICROGRAPHY | 92 |
| VI. MEDIUM-POWER PHOTO-MICROGRAPHY (<i>concluded</i>) | 109 |
| VII. HIGH POWER, OR CRITICAL PHOTO-MICROGRAPHY | 134 |
| APPENDICES | 147 |
| INDEX | 157 |

LIST OF TEXT ILLUSTRATIONS

| FIG. | | PAGE |
|----------------|--|------|
| 1. | MIXED-GAS JET AND STAND, BY NEWTON & CO. | 4 |
| 2. | MIXED-GAS JET, BY BEARD—AS USED BY THE AUTHOR. | 4 |
| 3. | MIXED-GAS JET, BY BEARD, AFFIXED TO AUTHOR'S STAND | 4 |
| 3 ^a | ROSS "RADIANT" MIXED-GAS JET ON STAND | 4 |
| 4. | GWYER MIXED-GAS JET | 4 |
| 4 ^a | BLOW-THROUGH JET, BY BEARD | 7 |
| 5. | BEARD'S REGULATOR—INTERIOR | 9 |
| 6. | BEARD'S REGULATOR—OUTSIDE APPEARANCE, ATTACHED TO GAUGE | 9 |
| 7. | HELIOSTAT, BY BAKER | 11 |
| 8. | HELIOSTAT, BY WATSON, AFTER DR. JOHNSON STONEY | 11 |
| 9. | DIAGRAM OF APPARATUS ARRANGED FOR LOW-POWER PHOTO-MICROGRAPHY | 14 |
| 10. | USE OF CONDENSER IN LOW-POWER PHOTO-MICROGRAPHY | 15 |
| 11. | CAMERA PORTION OF A SIMPLE FORM OF APPARATUS FOR LOW-POWER PHOTO-MICROGRAPHY | 24 |
| 12. | RAILED SLIDING-PORTION TO CONTAIN ARRANGEMENT AS GIVEN IN FIG. 11 | 24 |
| 13. | APPARATUS COMPLETE | 26 |
| 14. | MECHANICAL STAGE FOR HOLDING SLIPS FOR LOW-POWER PHOTO- MICROGRAPHY | 26 |
| 15. | DIAGRAM—ONE POSITION OF APPARATUS FOR PHOTOGRAPHING "CULTURE- TUBES" | 27 |
| 16. | DIAGRAM—ANOTHER POSITION OF APPARATUS FOR PHOTOGRAPHING "CULTURE-TUBES" | 27 |
| 17. | DETAILS FOR CONVENIENTLY HOLDING LIMELIGHT WHEN PHOTOGRAPHING "CULTURE-TUBES" | 29 |
| 18. | ARRANGEMENT OF SIMPLE KIND FOR ENLARGING NEGATIVES ON BROMIDE PAPER | 29 |
| 19. | STAND FOR PHOTO-MICROGRAPHY, BY BAKER | 49 |

| FIG. | | PAGE |
|------|--|------|
| 19a. | STAND FOR PHOTO-MICROGRAPHS, BY BECK | 49 |
| 19b. | BECK'S LAMP FOR MICROSCOPE WORK AND FOR PHOTO-MICROGRAPHY | 50 |
| 20. | STAND FOR PHOTO-MICROGRAPHY, BY SWIFT & SON, AFTER PRINGLE | 51 |
| 21. | STAND FOR PHOTO-MICROGRAPHY, BY ROSS & Co. | 52 |
| 22. | STAND FOR PHOTO-MICROGRAPHY, BY WATSON | 52 |
| 23. | STAND FOR PHOTO-MICROGRAPHY, BY ZEISS | 52 |
| 24a. | STAND FOR PHOTO-MICROGRAPHY, SIMPLE FORM AS USED BY AUTHOR | 54 |
| 24b. | STAND FOR PHOTO-MICROGRAPHY, SIMPLE FORM WITH ACCESSORIES | 54 |
| 24c. | STAND FOR PHOTO-MICROGRAPHY, PLAN OF APPARATUS, FIG. 24a. | 54 |
| 25. | VERTICAL APPARATUS, BY WATSON AFTER VAN HEURCK | 56 |
| 26. | VERTICAL APPARATUS, BY ZEISS (NEW PATTERN) | 57 |
| 27. | VERTICAL APPARATUS, BY ZEISS (NEW PATTERN) | 57 |
| 28. | MICROSCOPE ADAPTED FOR PHOTO-MICROGRAPHY, BY BAKER, AFTER NELSON | 60 |
| 28a. | MICROSCOPE ADAPTED FOR PHOTO-MICROGRAPHY, BY BECK | 61 |
| 29. | MICROSCOPE ADAPTED FOR PHOTO-MICROGRAPHY, BY POWELL & LEALAND | 62 |
| 30. | MICROSCOPE ADAPTED FOR PHOTO-MICROGRAPHY, BY ROSS & Co. | 63 |
| 31. | MICROSCOPE ADAPTED FOR PHOTO-MICROGRAPHY, BY SWIFT & SON | 64 |
| 32. | MICROSCOPE ADAPTED FOR PHOTO-MICROGRAPHY, BY WATSON, VAN HEURCK MODEL | 65 |
| 33. | MICROSCOPE ADAPTED FOR PHOTO-MICROGRAPHY, BY WATSON, EDIN- BURGH MODEL | 66 |
| 34. | MICROSCOPE ADAPTED FOR PHOTO-MICROGRAPHY, BY WATSON, FRAM MODEL | 67 |
| 35. | MICROSCOPE ADAPTED FOR PHOTO-MICROGRAPHY, BY ZEISS, AS USED BY AUTHOR | 68 |
| 36. | MICROSCOPE ADAPTED FOR PHOTO-MICROGRAPHY, BY ZEISS, SPECIAL PHOTO MODEL | 69 |
| 37. | FINE ADJUSTMENT, AFTER WATSON | 71 |
| 38. | FINE ADJUSTMENT, BY BAKER—CAMPBELL DIFFERENTIAL SCREW | 72 |
| 39. | OBJECTIVE CHANGER, BY ZEISS | 73 |
| 40. | SHOWING INCORRECT POSITION OF LENS ON CAMERA | 74 |
| 41. | NEW ADAPTABLE MECHANICAL STAGE, BY BAKER | 76 |
| 42. | MECHANICAL STAGE (ADAPTABLE), BY BAKER, MAYALL PATTERN | 76 |
| 43. | MECHANICAL STAGE (ADAPTABLE), BY ZEISS, MAYALL PATTERN | 76 |
| 44. | REFRACTION OF LIGHT—SINE LAW EXPLAINED | 82 |
| 45. | DRY AND IMMERSION LENSES, PATH OF RAYS IN EACH | 83 |

LIST OF TEXT ILLUSTRATIONS

X

| FIG. | | PAGE |
|------|---|------|
| 46. | DELICACY OF LENS-MOUNTS WITH OBJECTIVES OF HIGH N. A. | 85 |
| 47. | ABBE'S APERTOMETER, BY ZEISS | 88 |
| 48. | STOP FOR GIVING DARK GROUND ILLUMINATION OR ANNULAR LIGHT, SPECIAL ARRANGEMENT BY AUTHOR | 95 |
| 49. | APLANATIC CONDENSER | 97 |
| 50. | UNCORRECTED LENS | 97 |
| 51. | OVER CORRECTED LENS | 97 |
| 52. | UNDER CORRECTED LENS | 97 |
| 53. | POWELL & LEALAND 1'40 ACHROMATIC CONDENSER WITH STOPS | 100 |
| 54. | BECK'S ACHROMATIC CONDENSER 1'30 | 101 |
| 55. | ZEISS ACHROMATIC CONDENSER 1'0 | 101 |
| 56. | AUXILIARY CONDENSER, MOUNTED BY WATSON | 105 |
| 57. | AUXILIARY CONDENSER, AFTER AUTHOR'S PATTERN | 105 |
| 58. | ARRANGEMENT BY ZEISS FOR GIVING OBLIQUE LIGHT | 111 |
| 59. | DIAGRAM EXPLAINING "AREAS" VERSUS "DIAMETERS" | 115 |
| 60. | DIAGRAM EXPLAINING "AREAS" VERSUS "DIAMETERS" | 115 |
| 61. | DETAILS OF A MEANS FOR EXCLUDING LIGHT AT JUNCTION OF CAMERA AND MICROSCOPE | 118 |
| 62. | HOW TO FIX MICROSCOPE ON BASEBOARD | 118 |
| 63. | VERTICAL ILLUMINATOR, BY ZEISS | 133 |

PHOTO-MICROGRAPHY

INTRODUCTION

By Photo-micrography is meant the art of photographing a magnified image. Seeing this implies reproduction of images of any amplification, so for convenience of description we may divide the subject into three heads :

1. **Low-Power Work** :—Treating with magnitudes from $1\frac{1}{2}$ to about 10 diameters ;
2. **Medium-Power Work**, which deals from 10 to about 600 diameters ; and
3. **High-Power or Critical Work**, which, commencing where moderate ends, reaches to about 3000 diameters.

It would seem as if there existed in this arrangement a very unequal division of the subject, especially that low power work should not extend beyond 10 diameters ; but it must be at once stated that up to this limit photo-micrography is quite a different matter, and indeed requires in point of fact an entirely different form of apparatus. We should, however, recommend those commencing to begin from the very commencement, inasmuch as the difficulties presented become greater and greater as the initial magnification increases.

Inasmuch as an artificial light is always required for all the three divisions of our subject, we shall first discuss illuminants in general.

CHAPTER I

ILLUMINANTS

OIL, incandescent gas, lime-light, and electricity have all been pressed into service. The first is a poor light, and when used necessitates a long exposure even with magnification of 200 to 300 diameters, but may be advantageously employed when using quite low-power work. Double wicks are to be avoided; one large wick used edgewise, excepting under special circumstances, is found more suitable. Camphor mixed with the oil—the amount seems of but little moment—is used to remove a large amount of the smell, but the best method really of getting over this trouble is to see that the lamp is scrupulously clean. For that purpose, the wick being removed, the whole lamp should be placed in absolutely boiling water and left for a few minutes. After submitting it to a repeated washing, it should be well dried and the wick kept away in a stoppered bottle. When the lamp is now used, after these repeated washings, if no oil be spilled over any part of it in filling, there will be but little smell, and what is then left the camphor mostly removes.

Incandescent gas is very good for low-power work, but is objectionable on account of the fact that if “critical light” be used, as explained hereafter, on focussing the mantle its uneven appearance is added to the picture, which, save under very exceptional circumstances, spoils its beauty.

But oil as well as incandescent gas are not to be recommended in high-power work for another reason. Both theory and practice demand the use of an illuminant for critical work with as near an approach as possible to a point of light. For the optical student this is easy to understand, but if the reader has any misgivings on the philosophy of the assertion, he can easily satisfy himself as to its correctness by consulting any elementary work on optics, and the formation of the optical image in the microscope.

Electric light on this score, however, offers the exact ideal of the photo-microscopist, as, of course, with the arc form, a point of light may be said to be continually

existent. One disadvantage, however, putting aside the difficulties of its production, maintenance, let alone its expense, outweighs all the advantages of its use. It arises from the fact that the point of light is *always* shifting: however slight, still it is *frequently changing its position*, so that the centring of the light with the optical axis of the microscope is frequently getting out of adjustment, and pictures with unequal illumination may as frequently result. In saying this we are fully aware that some photo-micrographers still champion its use, but we are equally cognisant of the fact that many have relinquished it on this very ground.

Still we feel bound to admit that the steadiness of the arc light has of late been much improved, and many lamps are now in the market of undoubted merit, to wit, one sold by Messrs. Newton & Co., Fleet Street, and another, which is perhaps better suited still, introduced by Ross & Co. quite recently.

Lime-light, however, is that mostly employed. It is used in two forms: *the mixed jet*, where the gases, oxygen and coal gas (or hydrogen), both under pressure controlled by regulators to be presently described, mix in the jet itself just before ignition; and the *blow-through* form, which may often advantageously be employed for low-power work, when the oxygen under pressure blows *through* and *into* a stream of house gas issuing from an independent source, such as from the ordinary house tap, from which it is led to the jet by means of a piece of rubber tubing.

The Mixed Jet.—There are several forms of “mixed gas” jet, but space will not allow us a description of them all; indeed, it does not seem to be necessary, as the same *idea* pervades the whole of them, and differences that do exist are those of minute detail rather than those of difference of construction. Jets do differ very much indeed from one another *in performance*, and we only mention some of those with which we are familiar.

Messrs. Newton & Co., of Fleet Street, the well-known opticians, sell an exceptionally fine jet designed by Mr. Lewis Wright, whose name, as associated with optical projection, is a household word. It has an ingenious means of cutting off the gases, we believe originally suggested by Mr. Pringle, of photo-micrographical fame. It is shown in Fig. 1, where not only is the jet itself figured, but also an improved form of stand, quite lately introduced, which permits of lateral and up-and-down movement, both governed by milled-headed screws. This is of great service to the photo-micrographer as well as the ordinary lanternist. But the jet we have ourselves mostly used with so much satisfaction is the high-power form designed by Beard. It is shown in Fig. 2 and also in Fig. 3, where it is seen dropped over a pin which is attached to the special stand of our own design which enables the operator to

PHOTO-MICROGRAPHY

Fig. 1

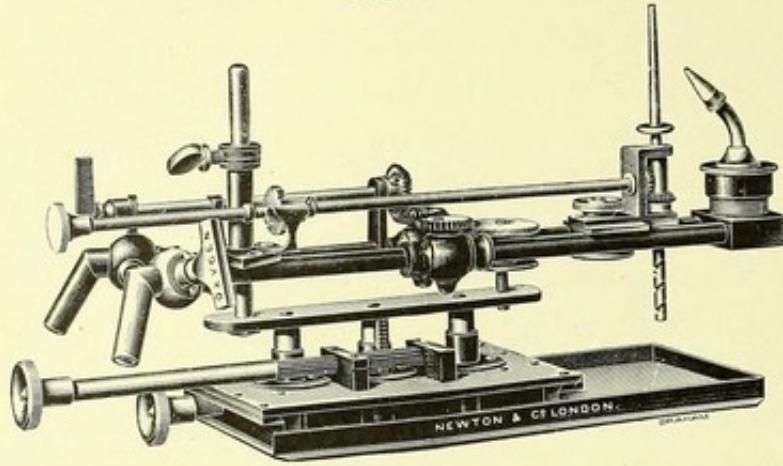

Fig. 2

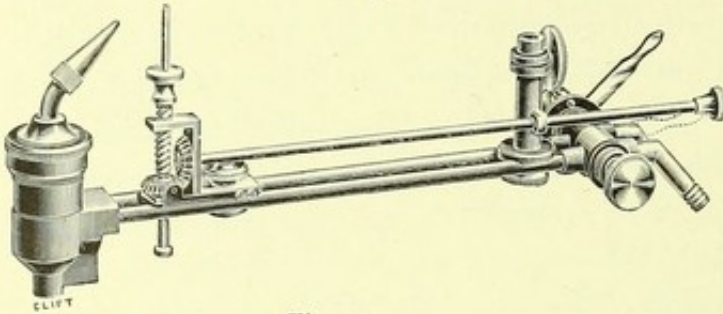

Fig. 3

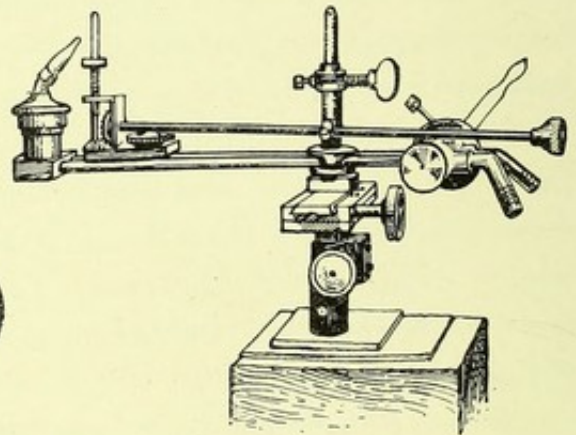

Fig. 3a

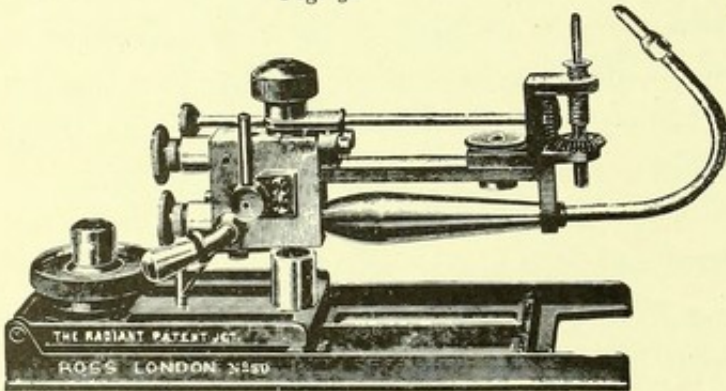
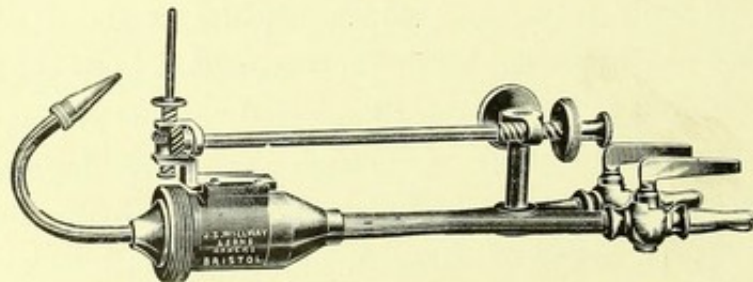

Fig. 4



move the light in all directions. The block almost explains itself. The ordinary arrangement for turning the lime is of course present, and in addition a handle for turning both gases down, when not immediately using the light, which is technically known as the "cut off." The oxygen is completely stopped by this arrangement, and only an exceedingly small amount of coal gas (regulated by a small additional thumbscrew, also shown in Fig. 3,) is allowed to pass on to the lime to keep it warm.

Underneath the jet is seen in Fig. 3 the stand of which we have spoken. One screw serves to shift the jet from side to side, the other raises it from below upwards, or *vice versá*, whereas a to-and-fro motion to enable the lime to approach nearer to or farther from the microscope or condenser is obtained by bevelling the wide foot of the stand itself so as it will pass evenly and smoothly through two guides fixed on the base board of whatever apparatus is used. This is a convenience, as the light can easily be shifted from one apparatus to another, as we shall presently show.

We have found this jet by Beard of sufficient intensity for all purposes, but still it is quite possible one of greater power might on special occasions be desirable. In this case we should recommend either the new jet by Gwyer (about which we shall very shortly speak), or the latest pattern quite recently introduced by Beard, or a still more modern jet by Ross & Co. to which our attention has been drawn whilst these pages were passing through the press. It is needless to point out that these high-power jets use an enormous amount of gas, sometimes up to as much as 10 feet an hour of oxygen as well as of coal gas. In our experience we have compared most carefully the high power of Beard and the most intense form by Gwyer, and we have found that there is but a small difference in intensity of light between them; but what exists, shows that the latter is a trifle the more powerful. Beard's, however, has a much smaller bore, and we think burns less gas.

Messrs. Ross & Co.'s latest jet, to which we have just referred, is shown in Fig. 3A. The stand has several movements, and the jet is exceedingly powerful. We are informed that critical tests endorse the extreme power of this jet.

The Gwyer Jet, Fig. 4, is another form of mixed gas illuminant and one of great power. Although it has not been very long for sale, it has already won many warm adherents. It is exceedingly well made, and has in our hands, when dealing with it experimentally, produced the most admirable results of the greatest intensity. It is manufactured by Messrs. Willway & Sons, who are a guarantee for its perfection. The firm issue a very neat pamphlet of instructions for working it, and their remarks are so

neatly compiled that with their permission we repeat them at length, as they apply almost equally well to any other form of mixed jet.

“ 1. Always work up the light by increasing the hydrogen side first, then increasing the oxygen until the best light is obtained for that amount of hydrogen, and repeating this until the jet very **slightly roars**. Then reduce by turning the oxygen down first very slightly, then the hydrogen until the light is at its best and perfectly silent.

2.—Always work the taps very slowly and steadily when it is important to get the highest results.

3.—Attend carefully to the distance of the lime from the nipple of the jet, and do not forget that the more gas you turn on the greater the distance must be between the lime and the nipple, or you will get a black spot on the centre of the lime instead of a bright one. This is done after you have adjusted your taps by working the lime backwards and forwards until you have the light at its best. Roughly speaking, for a low pressure about $\frac{1}{8}$ inch will not be far off, gradually increasing the distance to $\frac{3}{8}$ or $\frac{1}{2}$ inch, as you open the jet taps more and more to increase the light.

4.—For the most powerful light, rack the lime up until the jet plays almost upon the bottom of the lime cylinder, which should be rendered incandescent right up to the top, and where it is imperative to maintain light for a long time at the utmost power, it will be preferable to remove lime with the tongs and invert it rather than lower the level very much, so that no portion of its incandescent spot may be sacrificed.

5.—For the greatest light use large limes of medium hardness, but when only a moderate light with extreme economy of gas is required, it will be far better to use a medium-size lime; very large hard limes do not yield such a rich light with a very low pressure of gas as a moderately hard medium-size lime; on the other hand, such limes must be turned frequently when used with full pressure of gas, and when working the jet at its utmost power. The smaller the bore of the nipple the quicker the pitting of the lime.

6.—Do not forget to rime out the hole in the lime until it will drop easily upon pin; if limes are forced down slightly upon the jet pin the expansion of the pin when heated must crack or burst the lime.

7.—If the jet becomes unduly hot by firing back it is probably leaking somewhere. Test the tap and front tube carefully: a very slight leak will cause trouble with a $\frac{1}{16}$ bore nipple.

8.—The Gwyer Jets will dissolve perfectly with a nipple even up to $\frac{1}{16}$ bore if the

dissolver is in good order. Never jerk the dissolver when using large bore nipples or jets with large mixing-chambers. Always move the handle slowly at first, but as quickly as you like after.

9.—Remember that you do not always get a strong light by turning on a large quantity of the gases. The mixture must be correct to get a perfect white light. There should be no hydrogen flame round the lime as with a blow-through. It is this flame that gives trouble with the heat.

The Gwyer Jet does not give a strong light by a larger consumption of gas, but through the more perfect mixture and adjustment of the gases.

10.—Keep the jet nipple clean and bright, and if your jet has a tendency to roar or hiss send it to the works to be tested. A very small accident will sometimes prevent the smooth working of a jet, and which generally takes only a few minutes to remedy. It is very rarely that any charge is made for repairs of this sort.

11.—The No. 1 and 2 jets are generally sent out with a $\frac{1}{8}$ inch bore nipple, but when not working to the full power a $\frac{3}{16}$ inch bore may be used with advantage, and a lime of $\frac{3}{4}$ inch diameter.

12.—The size bore of the nipple should be in proportion to the light required if the jet is to be worked to the best advantage. A whiter light will be obtained with a $\frac{1}{8}$ inch bore at full pressure than a $\frac{1}{16}$ inch at half pressure, each consuming approximately the same quantity of oxygen. The lime also should be proportional to the amount of light: a small lime will give the best result with a small bore nipple."

Fig. 4a

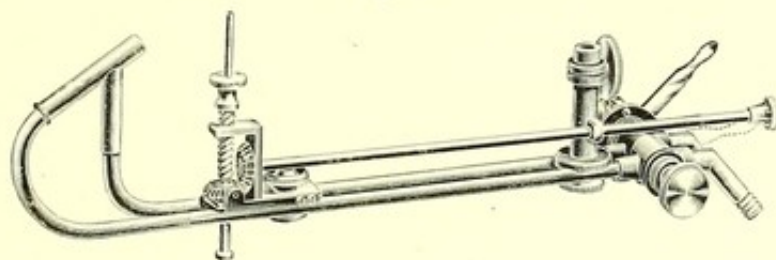

The Blow-through Jet (Fig. 4A).—This form is the easier one to work, and to those commencing the safest. It consists of two tubes to which the oxygen and coal gas are respectively attached by india-rubber tubing. The coal gas is lighted first and the oxygen then turned on, which "blows through" the stream of coal gas, and then is made to impinge on the lime. Too **much** oxygen will blow out the coal gas, too **little** will give but a feeble light.

Whichever jet be used the oxygen **must** always be under pressure, and if the

mixed form of jet be employed, the coal gas must be so as well. The compressed gas, whether oxygen or coal gas, is contained and stored in steel bottles, and as these receptacles have to be of sufficient strength to sustain enormous pressure—which, as a matter of fact, in a full-charged bottle is about eight times the amount employed in a modern locomotive—it is necessary to say a few words about them. We strongly advise every purchaser of one of these cylinders to go to the headquarters of the leading gas compressors in England—we refer to Messrs. Brin's, of Horseferry Road, Westminster. Their cylinders may be considered absolutely safe, both for carriage and use, because the company have made the most careful and exhaustive tests and elaborate and costly experiments that can possibly be designed to ensure perfect workmanship, perfect material, and perfect testing. No expense has been spared in this department, and whether the customer orders it or not his cylinder is periodically overhauled and tested, being destroyed if showing the least signs of weakness.

We regret to say that one London firm apparently does not feel bound by the recommendation following the careful and rigorous investigations of the Board of Trade, and has been known to send out cylinders made of metal which is positively and absolutely condemned by the Board in question. This is a subject which should occupy the attention of every lanternist and user of the limelight, and they should avoid having anything to do with cylinders badly made. The only advice that can be given in the matter, seeing it is impossible for a customer to analyse the steel of the cylinder sent to him, is to have no compressed gas except from those who not only conform with the regulations of the Board of Trade in question, but who mainly were the investigators in the whole subject from the first. We refer to Brin's Oxygen Co., of whom we have already spoken; and in saying this it must be distinctly understood the writer has no interest directly or indirectly in the company, but merely makes this statement as a guide to those he is attempting by these remarks to assist.

One more point also should not be overlooked: seeing that the greatest danger is caused by mixing oxygen and hydrogen unless in a properly appointed jet, so it is exceedingly dangerous to have interchangeable cylinders, that is to say, those that can be filled to-day with oxygen and to-morrow with hydrogen, for it is very obvious that an explosive mixture may thereby be readily formed which, the instant the unfortunate operator applies a light, causes an explosion hardly less terrific than that of dynamite or gunpowder.

Brin's Oxygen Co. have now for some years instituted a plan which utterly prevents any possible accident of this description, for the oxygen cylinders have a

right-handed thread, and those for coal-gas a left-handed one. It is, therefore, impossible for any employé accidentally to fill a cylinder used for one gas with the other, for the screws will not fit, and cannot be made to do so. In closing these remarks we regret to further add that firms still exist in London who sell both gases cheaper, and as a matter of fact not so pure, who still refuse to adopt these ingenious precautions, which leads us once more very obviously to select the same firm that we have already named, even if it were for this reason alone.

To resume, no accident can possibly happen when using the "blow-through" jet,

Fig. 5

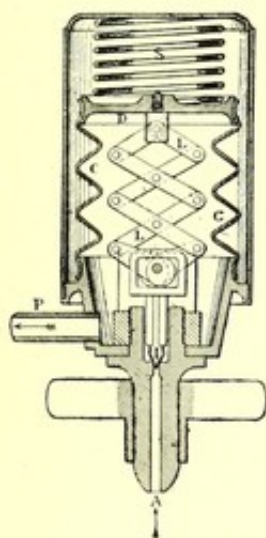
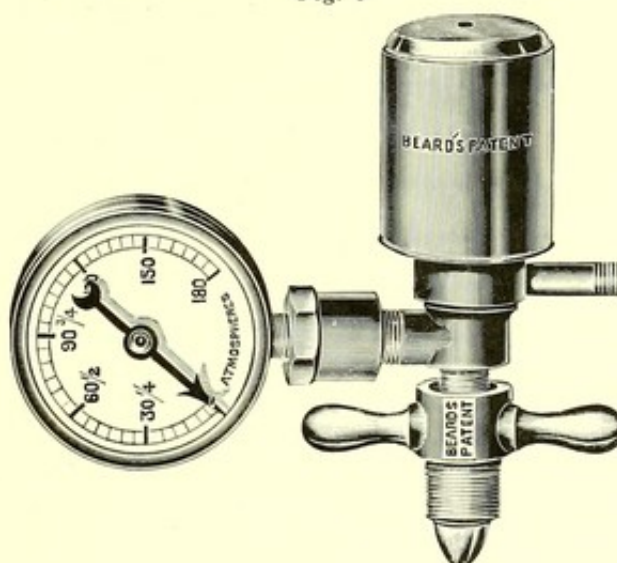

Fig. 6



for, as before stated, using too much oxygen simply causes the light to go out, which is of no serious consequence.

In all cases regulators must be fitted to the gas bottles. When employed for mixed jets these can be "matched," but even that is not absolutely necessary. The regulator which we have used with never-failing satisfaction is also made by Mr. Beard, who has rendered it after numerous experiments and long experience almost perfection; we cannot find any fault with it after *several* years of constant use. A cut is given in Fig. 5 which shows its internal mechanism to depend upon an ingenious arrangement of a "lazy-tongs" design. In Fig. 6 the regulator is shown attached to what is known as a gauge. The object of this additional piece of apparatus is to indicate how much gas is contained in a bottle. It must be stated here that no gas "regulator" or "gauge" once used for coal-gas should ever be employed for oxygen; there are chemical reasons which forbid interchange of this description.

Mr. Beard now makes right and left-handed regulators and gauges so that they fit the right and left-handed nozzles of the oxygen and coal-gas cylinders; hence there is no danger of an interchange being made in a moment of forgetfulness. For a full and detailed description of gas bottles, regulators and gauges, the reader is referred to an excellent brochure on the subject by Mr. K. S. Murray, M.I.M.E., engineer of the Messrs. Brin's works, Horseferry Road, Westminster.

To use the mixed jet is somewhat of an art, but one that may quickly be learnt. On the brass tube of each "regulator," where the india-rubber tube is attached (P in Fig 5), it is a great convenience to have fixed, in addition, a common tap, for there are times when one may want to shut off the gas temporarily, or even suddenly as in the case of an emergency, and this can be done with *far greater speed and ease* by these common gas taps than by shutting off the cylinders themselves. A common tap suffices, as there is no pressure worth noting in this situation.

To start the light, having placed the lime upon the pin made for its support, the screws which regulate the amount of gas passing into each pipe of the jet are screwed *completely down*, both gases being gently turned on at the cylinder, and if gauges are used as shown in the diagram, they can be watched to see when the valves are sufficiently opened. The "cut off" handle is then placed *horizontal*, which means both gases, if not controlled by the screw-down valves in the tube of the jet to which reference has been made, would rush *on* towards the lime. We undo first the red one, which permits the hydrogen or coal-gas to pass to the jet and thus impinge on the lime.

It is then lighted. Still leaving the "cut off" untouched, slowly turn on the oxygen screw-down-tap on the jet until the light is quite bright. These two screws must now be slowly opened one against the other till the best light is obtained, always remembering that it is better to turn the hydrogen on first, as suggested in the Gwyer pamphlet. If too much oxygen be put on, the light will fade and require more hydrogen, but we recommend any one using the mixed light having a few lessons before attempting it. With Beard's jet very little "snapping" occurs, but in some forms made by other makers the slightest misproportion of oxygen will produce it. There is no danger in this snap in a well-appointed jet, but we venture to suggest to any reader who is contemplating buying this form of illumination only to go to best makers. Cheap jets are always to be avoided for they are often dangerous.

Before quitting the subject it should be again noted that the gases should always be turned on *gently*, especially when using a gauge, as accidents have been known to

occur from a too sudden "jerking on" of the oxygen. To avoid the possibility of this accident, Mr. Beard (and others, we believe) have arranged a "check" which is placed in the mouth of the gauge, which only allows the oxygen to pass very *slowly* no matter how much the *gas bottle valve is turned on*. That is to say, even if by accident this latter valve is violently opened an undue amount, the gas only enters the gauge quite slowly. It is an invention which can be added at the small expense of five shillings and is well worth the money.

So far as relates to limes, the very best "hard" Nottingham variety is always to be bought for the mixed jet, but the "soft lime" does quite well for the blow-through

Fig. 7

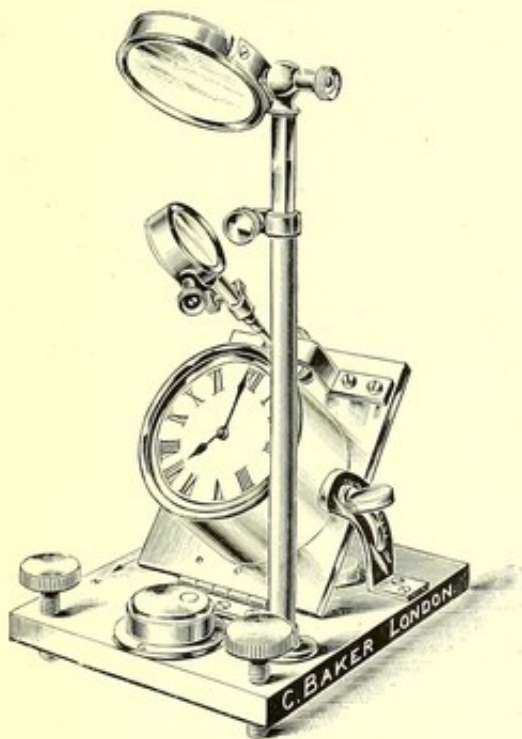
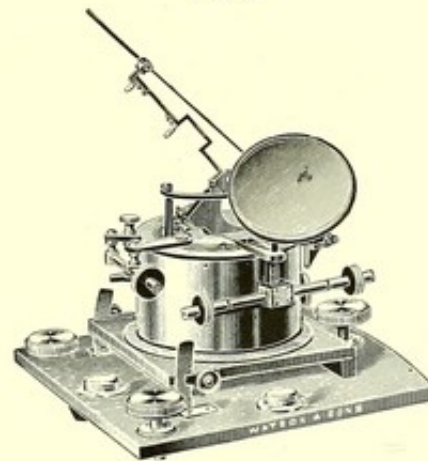

Fig. 8



and is cheaper. Messrs. Zeiss have introduced a small lime which is some compound of Zirconium. We have tried it and like it very much. Ordinary limes rapidly wear away under the intense heat of the mixed jet, and require frequent turning, but these of which we have just spoken are extremely hard and do not apparently require any attention for some protracted interval. Their only fault seems to be their price and that a special arrangement of the jet is required for their use.

So far as to the use of artificial lights. Another illuminant exists, however, which is almost a necessity for a few picked specimens—we refer to the sun. This, when employed, requires some form of special arrangement, owing to the rotation of the

earth, for it is never still for more (apparently of course) than a few seconds together. That is to say, when employing it just as the light is made central in a manner to be hereafter explained, the sun apparently moves and does not retain its position in the field of view long enough to enable a photograph to be taken with its use. The special form of apparatus to keep it so is called a heliostat and is shown in Figs. 7 and 8. We believe the form (Fig. 7) which is sold by Baker, of Holborn, answers the purpose very well indeed. Other forms are made, notably one after Prazmowski, by Messrs. Bésu, Hauser & Co. of Paris, and by Hartnack in Potsdam. Messrs. Watson & Son of Holborn also supply an ingenious arrangement devised by Dr. Johnson Stoney, shown in Fig. 8; neither of these two are personally known to us, but by repute they are generally acknowledged to be exceedingly good although rather costly. Any kind of heliostat must be made for the latitude of the place, and as full directions for their setting up and use are issued by each maker a detailed description need not be here given.

CHAPTER II

LOW-POWER WORK

IN this chapter, **Section I.**, low-power photo-micrography and the apparatus used are explained.

Whilst **Section II.** is devoted to (i) development of the negative ; (ii) the making of lantern slides ; and (iii) the printing of positives on paper.

SECTION I.—LOW-POWER WORK

It may surprise the reader to hear that, with low-power work, the microscope is entirely dispensed with, because the narrowness of the tube so curtails the field of view that the resulting picture is practically of no service. To get over this difficulty resort is made to the ordinary photographic camera, which for many purposes need not be larger than quarter-plate size, having an extension of from twelve to thirteen inches. We know, in stating this, that many fellow-workers prefer one of larger, say half-plate size, but after considerable experience, save perhaps for special pictures required of much larger size than usual, the gain in use of a larger instrument we have never found commensurate with the increase of cost both initially and to maintain, for it is self evident every half plate costs double that of a quarter plate. When photographing bacteria, diatoms &c., where small fields are only necessary, we may go still further and say the larger size is a decided hindrance, as the "carriers" for the use of smaller plates are rarely fitted accurately enough, with respect to "register," to admit of a really sharply focussed picture being taken.

The arrangement of the apparatus in its entirety is shown in Fig. 9, which in a measure explains itself. Speaking in the first place *quite* generally, the camera is supposed to be placed on a rigid support, and the lens is shown fixed in the front of it. The object is placed at S, where it is supported in a manner to be further described, whilst the illuminant is a limelight enclosed in a box provided with a

large condenser,* shown at C. The light from the limelight jet, which should be a "mixed one," falls first upon a piece of ground glass which is interposed between the source of light and the condenser.

The box itself enclosing the light may be 16 inches long, 13 inches wide, and 15 inches high. These dimensions, although large, we have found most convenient, inasmuch as there is no fear of the wood becoming injured by the direct heat of the limelight. A suitable chimney to allow the escape of the fumes is shown rising from

Fig. 9

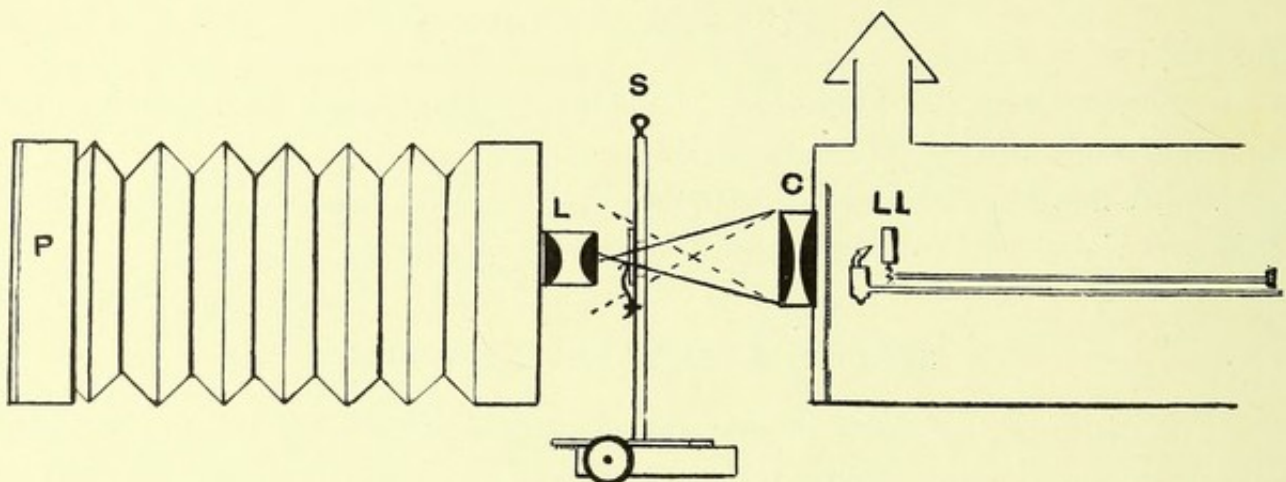

the summit. The arrangement for turning the lime is also drawn in the diagram, but as this is usually supplied with the best form of jets we need only refer to it.

Between the light and the condenser, as before stated, we usually interpose a piece of ground glass, which causes a general diffusion of light, thus rendering the entire field of the photograph equally illuminated. It is not absolutely necessary that the ground glass should be interposed between the condenser and the light, for there are those who prefer placing it between the two lenses which compose the actual condenser itself. In most condensers this is easily done, but in some the space between the component lenses is so small that it will not admit anything, even the thinnest of ground glass. If placed in this position, too, there is a danger which ought to be pointed out, namely, that the ground glass may very possibly shake and thereby scratch the surface of one or other lens, and so imperil its perfect performance. If there is no room between the lenses of the condenser there is no option but to put the ground glass where first mentioned, as it is not a satisfactory plan to place it between

* We say a large condenser because a small one will not cover the slide so as to illuminate it equally unless *very* close, which is inconvenient.

the condenser and the object, for it causes a curiously granulated effect in the final picture, which utterly spoils it.

A compound condenser of at least 6-inch diameter, even when taking a quarter plate negative, should always be used. Its focus is of no material importance, but should not be too short, for if so, the close approximation of the lime which then becomes necessary may threaten the safety of the back lens, a matter of importance in these large condensers, seeing that they are expensive.

A question may now be asked, Of what advantage is the condenser, especially as the light is so powerful? When dealing with the use of a *substage* condenser to the microscope further on, we fully explain the matter in its entirety, relating all that is

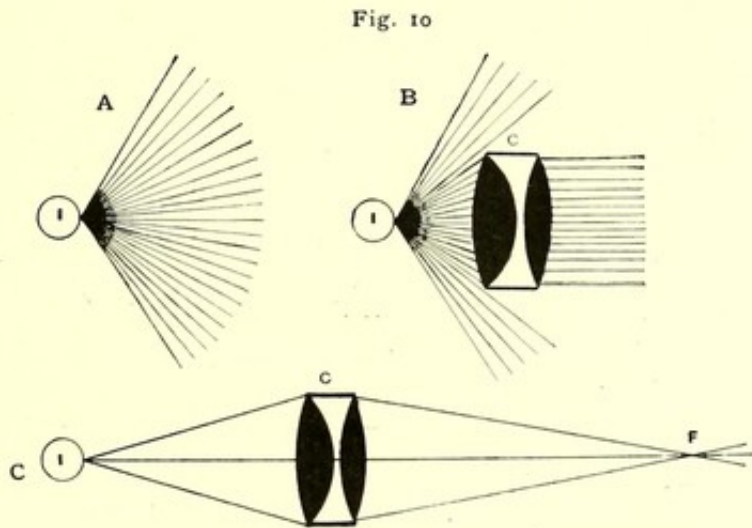

necessary for the photographer to know, so a complete reply here seems unnecessary. Still, to make the matter intelligible so far as required at the present moment, we may briefly state the object of a condenser *here* is to gather light from the illuminant and to place the rays in such a position that they may impinge on the object at the proper angle; and further, that by its means the object may be illuminated uniformly in all its parts. To the optical student the following explanation may still more appeal. Consider Fig. 10.

In Fig. 10 A is shown the rays of light issuing in all directions from the illuminant I. In Fig. 10 B is seen a condenser C placed in such a manner that its distance from I exactly equals its focus. The consequence is that rays of parallel light issue from it, and these will continue parallel to infinity if all the optical conditions of the condenser were perfect and the light a point. This arrangement is required for certain purposes. In Fig. 10 C the condenser is placed so that its

distance is *greater* than its focus: this causes the rays to come to a focus say at F. Certain class of work demands this position in preference to the other. It will be seen now how the condenser is used, not only to grasp light, but to direct the rays in given directions. A large one is best because its central rays will only be employed.*

To resume. Owing to the intense heat to which the glasses of the condenser, especially that one nearest the light, are subjected, it has been proposed, and used by many, that an additional protective glass plate should be interposed between the condenser and the limelight, but we have found this to be unnecessary, especially when using the ground glass in that situation, for that in itself affords a protection to the posterior lens, and the less the amount of glass interposed between the light and the object the stronger will be the resulting illumination.

One more point of practical importance must not be overlooked, and that is, the photographer should carefully examine the condenser before using it to see that the lenses are *quite* loose in their cells, for if they are in the least measure tight when cold, the expansion which takes place on their becoming heated will surely cause one or both of them to crack.

Having explained the position and details of the light, its box, and the condenser, we will pass on to consider the support (marked S in the diagram) for the object we propose to photograph. Let this be, for example, a moderately-sized spider, and that we want to enlarge it to fill a lantern slide. These are procurable laid out on an ordinary microscopical slip 3 by 1 inches. It is placed upon the support S (which, it is seen in the diagram, is merely an upright piece of wood with a hole in it), being held there in position by two ordinary clips, such as are used in the microscope. They consist of two pieces of spring, each being mounted on a brass pin. The support is seen to be fixed at right angles to another piece of wood, which is nothing more than the base board of a camera, capable of being racked to and fro by the milled head shown beneath. As will be explained hereafter, this is for the means of final focussing.

We next come to a difficult part of our subject, namely, the selection of a lens. It has been already stated that the microscope affords too limited a field of view for our requirements, a remark which also applies to the use of microscopical objectives. It is easy to understand this, for the field of view for which that class of objective is corrected is naturally small, being only intended to be used with the microscope. The consequence of this is that if a microscopical objective be placed on the camera at

* This will be better understood when the subject is treated of in its entirety further on.

L in the diagram, the centre of the field, it is true, will be seen on the ground glass at P, well and clearly defined, but the portion surrounding the centre and extending to the edges will be fuzzy and useless as shown with quite a small specimen in Fig. 6, Plate I. If we had been photographing the spider shown in Fig. 3, Plate I., the legs would have been fuzzy whilst the body was sharp and well defined.

An ordinary photographic lens is the next thing that suggests itself, but here we are met with a two-fold difficulty: First, suppose, for instance, we were to use a 4 or 5 inch rapid rectilinear, we should require so very great an extension of camera that it would be impossible to reach the focusing screw of the support S without the assistance of a "long arm" such as is used with an astronomical telescope. It is not advisable to make the apparatus more cumbersome than is necessary, and so the only escape from the difficulty is to have a lens of shorter focus.

We must point out here, as perhaps the most suitable place, that the accurate and final focusing should always be done by moving the object rather than by moving the ground glass, as is usual when taking an ordinary photograph. The reason is not far to seek, but to explain it intelligibly we must for a moment enter into the optical aspect of the situation; it is worth a moment's consideration, as it at the same time explains the second difficulty connected with using ordinary photographic lenses for photo-micrography, which should not be omitted.

When photographing in the ordinary manner—say, for instance, taking a view of a landscape—the rays from distant objects impinge on the lens, usually in more or less parallel bundles, and the ground glass is placed at the short conjugate focus, the lens being constructed by the optician with that idea in view. But in making an enlargement with a photographic lens the conditions are exactly the reverse, for then the short conjugate focus is between the lens and the object, and the long one between the lens and the ground glass screen. It will be seen therefore, that the lens is constructed for one purpose and used for another, hence it is not difficult to understand the absence of critical perfection in the resulting image. It has been suggested, to get over this difficulty, that the lens should, when used for photo-micrography, be turned the opposite way, and this improves the resulting definition with almost any lens excepting a rapid rectilinear, but with this type we have never been able to find any pronounced improvement by so doing, and, indeed, on considering its optical construction we should never suppose that it would.

Another class of lens has been suggested for photo-micrography, and we have often used it where the object is large and the required magnification is small: we refer to a diminutive portrait lens of about 3-inch focus built on the Petzval principle.

When it is used in the reversed manner, it certainly has given very good results, as shown in Fig. 5, Plate I.; still, however, if the magnification required was over $1\frac{1}{2}$ to 2 diameters, it was only with difficulty we found ourselves able to reach the milled head to focus with.

Messrs. Dallmeyer, however, have constructed a small rectilinear of about $1\frac{3}{4}$ -inch focus, which with magnifications over $1\frac{1}{2}$ to 2 diameters has produced most admirable results, and were it only constructed to work equally well in red, green and violet rays, we should have no possible fault to find with it, as it is very inexpensive. Examples of its performance are shown in Figs. 1 and 2 and 7, Plate I. But the finest type of lens with which we are acquainted has been recently introduced by the firm of Zeiss, and called by them the "PLANAR." It has been constructed from computations by Dr. Rudolph for the especial purpose of photo-micrography, and it works equally well in all colours. See Figs. 3 and 4, Plate I.

There remains yet one more point concerning the selection of lenses for certain sized objects, which relates to what is called their "Covering power," about which at present nothing has been said. How it applies to the subject under consideration is not altogether easy to point out, and cannot be found described as such in any text-book with which we are familiar. But as it is of such practical importance to the photographer it may be well to try and explain the matter.

By the "size of plate covered" is meant that if a lens is used in the ordinary manner, say upon distant objects (to get parallel rays), the diameter of the plate covered at the focus on the ground glass is of definite dimensions. That is to say, all objects outside this limit are ill-defined, and the light falls off more and more until the illumination becomes almost *nil*. To see how this applies to our subject we must treat the matter by regarding the rays in the opposite direction, *i.e.*, the area of defined illumination of a given object which the lens can *cast on the plate is limited to the size of the covering power already described*. Say with the 50 mm. lens. Its area of defined illumination is limited to about $1\frac{1}{4}$ by $1\frac{1}{4}$, hence it cannot be used to magnify objects larger than $1\frac{1}{4}$ by $1\frac{1}{4}$, for the image on the ground glass will fall off so that the edges are imperfect! If therefore the object *be* larger than about 1 inch by 1 inch, there is no alternative but to use another lens of *greater covering power*.

This is exactly what happened in photographing the Frontispiece. The Cardinal Beetle was just beyond the limit of area for the 50 mm. Zeiss Planar, hence we had to employ a Ross-Zeiss Planar, of different focus (83 mm.) and larger covering power (kindly placed at our disposal by the firm) to take the photograph. But as the Ant-

lion was initially *smaller* and within the "covering power" of the 50 mm., so that lens could be employed for that object.

It will be seen now, it is hoped, what an important point this "covering power" is when buying a lens. We have often been asked the best "all round" Planar to buy; but it is obvious we cannot say unless the usual size of object be given that it is desired to photograph.

It is needless to add the focal lengths of these admirable lenses differ and so do their covering power, but all details are given in either Ross or Zeiss's catalogue. The 50 mm. at work is also shown in Figs. 1, 3, 4, 5, and 7, Plate II.

The camera may be of any size, but as before stated we have usually found the quarter plate sufficient for small subjects, when the magnification required is small. In our own special case we have both sizes made interchangeable, which is at least a convenient arrangement. When using either form it is of great service to have an auxiliary front which drops on to the camera where the lens usually fits into the camera. By this expedient we are enabled to increase our camera length another 6 or 8 inches for the quarter plate, and 2 to 3 feet for the half plate. As will be seen hereafter, a special arrangement is made for these purposes in the excellent apparatus made by several firms.

Having thus described the apparatus, only one thing remains before taking the photograph; that is to select a suitably sensitised plate. We have tried most of the brands in the market, but owing to the fact that so few are isochromatic, the selection practically rests with three or four makers. The object of using isochromatic plates will be explained hereafter, and we believe that, as far as isochromatism is concerned, the Cadett plate is the most perfect, but it is very slow, which is a great objection to its use. Not that the exposure need be very long with this class of photomicrography, but we must never lose sight of the fact that the rays emanating from the limelight being focussed on the object, will very readily make it melt, and therefore it is obvious, within prescribed limits, the quicker the plate the more safety to the specimen. It is quite true that a water-bath can be interposed between the condenser and the object, but it is very inconvenient to use with this lower power work, for the water quickly begins to generate bubbles of steam, which, should they adhere to the sides of the trough, will cause all manner of markings in the resulting picture. We have rarely had the accident happen of melting a slide, although we admit that at times they have become very warm, but if a prolonged exposure had been added to the time necessarily occupied in focusing the object, it is highly probable such an accident would have occurred more frequently.

Lumière's plates are much prized by some photographers, but we have little fault to find with the medium isochromatic plates manufactured by Edwards. They are most uniform in grain and similar in sensitiveness, easy to develop, and very free from fog, both when using hydrokinone or pyro. We know that others are strong advocates of the Ilford isochromatic plate, but must admit that although they are cheaper we have never felt any inclination to substitute them for the brand previously mentioned. In conclusion, whilst making these comments, it should be distinctly understood that many of our friends have different experiences, some preferring one make and some another, and we think it only fair to say so.

Every plate must be "backed," and we have no reason to find fault with the "backing" solution sold in tubes under the name of "Forrester's Effective Backing." It must be dabbed on the glass with a pad and not smeared, as smearing leaves streaks which frequently show in the final picture. The reason of that is this: When a plate is not "backed" at all, the direct rays impinging upon the film, passing through the emulsion, are reflected off the back of the glass again into the film at definite angles, which depend upon the thickness of the glass and its refractive index. When a plate is "backed," however, these are absorbed by the "backing," and if that is unequally distributed some of them escape, whilst others are absorbed. This would in some cases not so much matter, but as "backing" always sensibly increases the exposure, so if the "backing" be well distributed over one part of the plate and not on another, the bad results referred to are really due to differing exposures on one plate, which are readily manifested when the negative is developed.

In the present day most plate-makers sell their plates ready "backed," which is a great convenience, for home "backing" is at the best of times a messy matter. Edwards's "antihalo" isochromatic plates are really exactly the same as those unbacked, which is mentioned here as some have thought they are coated with a slower emulsion. This is not true; their apparent slowness is due to the fact that all "backed" plates require more exposure than those which are not so treated.

Being now prepared to take our photograph we will go practically through the process from beginning to end. The mixed limelight being ready, the camera is set in position, the object being placed upside down on the support S. The rays of the limelight are made to converge in such a manner that their point of union is on the lens side of the support shown in Fig. 9 by the thick lines, the dotted ones being the incorrect position. In our experience this is imperative to obtain a good image. This is readily done by pushing the limelight to and fro, that is to say, nearer or

further from the condenser, the tray of the jet being provided with a groove to enable such movement to be done with ease and regularity.

We next look at the ground glass of the camera, which is placed at P (the lens being, of course, screwed in its place at L), and adjust the specimen until it is central. Drawing the head back some 10 or 12 inches will enable the whole field of view to be better scrutinised than it would be if the head were placed nearer. If it is seen that one side is brighter than the other, either the lime jet itself must be pushed a trifle from side to side on the supporting pin provided with the apparatus, or, what is better, the whole limelight box with its condenser should be bodily shifted from side to side. If the light be unequal at the top or the bottom the lime must be raised or lowered as occasion requires. The greatest care should be exercised in getting the illumination equal, and it requires some amount of practice to be able to do it. It repays the trouble, however, for it is exceedingly provoking after taking what might be otherwise a good photograph, to find that a portion of it is not so bright as the rest, as shown in Fig. 6, Plate I. There is another reason, too, why the light should be carefully centred, for even in this low-power work perfect definition certainly depends in a measure upon it.

Assuming then we have got over this trouble, we now examine our specimen upon the support S, seeing that it is firmly clamped by the spring clips already mentioned. We then push the extended camera quite close to the object—say when using the 50 mm. lens to about an inch off it. It will be now necessary to push the bellows to and fro till we get the image on the screen. If such image be too large or too small it is very obvious the camera must be removed further off or brought nearer to the object, the bellows being readjusted to obtain the rough focus on the ground glass screen. Some little practice is required in this matter because the exact length of camera and the exact distance of the lens from the object are the factors for producing a definite amount of enlargement. It may be necessary with small objects, when we want 10 diameters magnification, to add the lengthening piece of the camera to which reference has already been made; in that case the lens may have to be pushed up almost in contact with the object. When the image is clearly seen and roughly focused by moving the ground glass it should always be measured, so as to enable the photographer to see whether the magnification is such as he desires. This should never be omitted, for it is often of great service at some future date to be able to refer to the number of diameters an object has been magnified; but besides this, it introduces an element of accuracy which, if the photo-micrographer does not already possess, he must rapidly learn as soon as possible. When taking negatives for the

purpose of obtaining lantern slides, this careful measurement is of great importance for as the size of the ordinary lantern plate is only about 3 inches square, it is very obvious, if the picture be elongated the entire length of the quarter plate, which is 4 inches, a portion of it can never be introduced in the lantern slide at all. To prevent this accident occurring it is a good plan to mark upon the ground glass with a pencil two distinct lines, which show the limit of the lantern slide.

The measuring being complete and the amount of magnification noted, focusing is now carefully made by moving the object itself by means of the milled head at S with a faint touch to and fro, and not by moving the screen; for this will be found to be an unsatisfactory method, only capable of explanation by a study of the optical nature of the image in this situation, which would be unsuitable at the present moment.

We now proceed to substitute for the ground glass the photographic plate (carefully backed) in its slide, and having "turned the lime," in case it takes to flaring at the moment of exposure, which would jeopardise the safety of the ground glass, we set the desired diaphragm and place the cap on the lens. Sometimes this simple procedure is difficult owing to the fact that the lens is not more than two thicknesses of its cap from the object. When this so happens a black card passed between the lens and the object, resting on the foot of the apparatus just above the screw shown in the diagram, will quite sufficiently cut off the light from the inside of the camera. Having drawn the slide it is well to wait for a few seconds to allow the "shake" in the whole apparatus to settle down.

Exposure will, of course, vary according to the diaphragm employed in the lens. F/16 to F/22 are about the limits. At the former aperture using the Planar lenses we have found the range of exposure is 2 to 5 seconds if the object be an uncoloured one, but much more if it be coloured.

It has been mentioned that the distance of the lens from the object and the camera length are factors for producing the required magnification. So they are, but it must not be thought that the focal length of the lens itself has been lost sight of. What has been said applies in a fashion to the use of the *same* lens. Seeing, however, it may be of service to the photographer to rightly understand where the focal length of any lens he may use comes in, we will conclude this section of our subject by giving a few formulæ, which, although they may not be rigidly correct, are quite correct enough for all practical purposes. We shall ignore the "covering power" here as it has been spoken of before, and confine ourselves to answering three questions:

1. Suppose first we want to magnify an object, say a house-fly, four diameters on our ground glass so as to make a lantern slide from our negative, and we do not want to use a camera length of more than, say, 10 inches; what lens is required?—

Let F =focal length of lens required; let M =magnification; let L =camera length.

$$\text{The formula here is, } F = \frac{L}{(M+1)}$$

$$\text{This becomes } F = \frac{10}{(4+1)} = \frac{10}{5} = 2 \text{ inches}$$

Therefore we require a 2-inch lens.

If we desire to work in millimetres, then :—

$$F = \frac{L}{(M+1)} = \frac{250}{5} = 50 \text{ mm.}$$

This means that we must have a lens of 50 mm. focus to give us a magnification of 4 diameters, with a camera extension of 10 inches (250 mm.).

2. Suppose now we want to know whether our camera will require the additional front to obtain a picture of 10 diameters on the screen, using the 50 mm. lens; as we know the limit of our lantern slide is three inches, so the object it is evident must be small or it will not all go on the plate. Presuming we are satisfied with a portion only showing, then the formula becomes—

$$L = (M+1)F = (10+1)50 = 550 \text{ mm. or } 22 \text{ in.};$$

our camera will need the front it is evident.

3. Lastly, we want to know what magnitude in diameters would our object be reproduced on the plate with a given lens and a given camera length. Say, for example, what magnification can we obtain with our 13-inch (325 mm.) camera, and no additional front, using still a 2-inch (50 mm.) lens. The formula here is—

$$(M+1) = \frac{L}{F} = \frac{325}{50} = 6.5$$

$$\text{as } M+1 = 6.5 \therefore M = 6.5 - 1 = 5.5 \text{ diameters.}$$

Or in inches—

$$(M+1) = \frac{13}{2} \text{ and } 6.5 - 1 = 5.5 \text{ diameters.}$$

If one wanted to use any other lens it is obvious that the same formula would apply.

Hitherto we have made no especial mention of the support for the camera and the slide holder; we merely mentioned that the camera and object-holder should be firmly supported, and that to obtain the right amount of magnification the camera

must be pushed up to the object to be photographed, or away from it, according to whether it required enlarging more or less. Those who have ever made any attempt at trying this, the most primitive form of photo-micrography, will have already found such apparently simple movement of the camera is often a very troublesome matter. After having put the specimen in the centre of the ground glass, and made the light uniformly even over the whole field, they may have proceeded, as it was pointed out they should never neglect to do, to measure the image, and note by comparison with the object the amount of magnification they were obtaining. Perhaps they then found the image too large or too small. It seems now only a simple matter to shift the camera forwards or backwards, but, as a matter of fact, they most likely found it a very troublesome operation because, unless it was shifted *exactly in the same axis*, all

Fig. 11

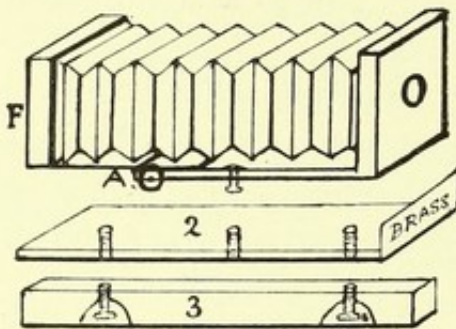

Fig. 12



the centreing of the light and the placing of the object into the middle of the plate, had to be done over and over again until the magnification was exactly what was wanted. We recognised this trouble when commencing the work some years ago, and then devised a simple form of arrangement which was so cheap and effective that we feel it may be of service to others to describe it somewhat fully. In Fig. 11 is shown the camera—roughly depicted, but clear enough for the purpose—thoroughly extended to about 12 or 13 inches, the base-board of the camera being seen at A, and the focusing screen at F.

The dotted lines through the base-board indicate where the ordinary screw hole is placed, by which in the field the camera is attached to the tripod. Below the camera in the drawing is seen another board marked 2; it is large enough to hold the camera, the face of which fits well against the metal end marked "Brass" in the diagram. Three holes are seen in it (the board), the centre one to take the ordinary tripod head screw (shown in its place in the base-board of the camera) which fastens the

board quite securely to the camera. It should be mentioned a little exactness is here required, so as to make the camera fit well home against the brass end referred to, but it repays the trouble, for if well done the camera should be quite firm and rigid, even though it is secured by this single screw. The other two holes are tapped to take the thumb-screws which attach No. 3 board firmly to No. 2.

It may be convenient to give the exact dimensions of the apparatus :

| | |
|---|--------------------|
| Camera length from end to end | 13 inches. |
| Width | 5 $\frac{3}{4}$ " |
| Board 2—Length | 13 $\frac{1}{2}$ " |
| Width | 5 $\frac{3}{4}$ " |
| Five-eighths of an inch thick, with a thin piece of brass at the end. | |
| Board 3—Length | 16 inches. |
| Width | 3 $\frac{1}{2}$ " |
| Thickness | 2 " |

All these three pieces are seen fixed together in Fig. 13, but the camera is not shown fully extended. When all three pieces shown in Fig. 11 are firmly fixed, it is easy to see the camera will travel in the slide shown in Fig. 12. This can be made to fit piece 3 in Fig. 11 without any trouble, but the board of which it is made should be constructed of 1 $\frac{1}{2}$ inch stuff, and the guide rails (which are tapped for the thick wooden screws shown black in the drawing) not cut out of too thin material. Ours were made of mahogany 1 inch wide and 1 $\frac{1}{2}$ inch thick. The length of the board found most convenient was 3 feet, and the width about 8 or 9 inches. Care should also be taken to get a well-seasoned flat piece of timber for this purpose.

It is very obvious now that if to the end of the railed board, Fig. 12, the object holder (shown at S in Fig. 9) be firmly attached, the whole apparatus can be easily placed on an ordinary studio camera stand and clamped in position in front of the condenser. One important convenience of this arrangement lies in the fact that a great amount of possible shake is thereby lessened, for, even if the camera, lens, or object be jarred the whole piece is thereby shaken in *one mass*, which does not affect the centreing of the picture or its adjustments; whereas, if the object had been separately supported apart from the camera, any touch to either would immediately have imperilled the focussing of the picture. This little point is well worthy of notice, as it is a help towards getting perfect results, saves time, and reduces failures.

In taking the photograph, then, the camera can be slid with perfect trueness to and fro, until, in fact, the magnification required is obtained; and it has only to be clamped by the wood screws passing through the mahogany rails, for all to be complete.

Another convenient arrangement is that shown in Fig. 14, for attaching to the support S in the diagram Fig. 9, p. 14. Practically it is something like the stage of a microscope. The slide is seen *in situ* and is capable of being moved in two directions by the capstan-headed screws shown in the drawing. A further improvement is to have the whole made to revolve on its axis. It may seem an unnecessary extravagance to have an arrangement of this costly description for low-power work; but the

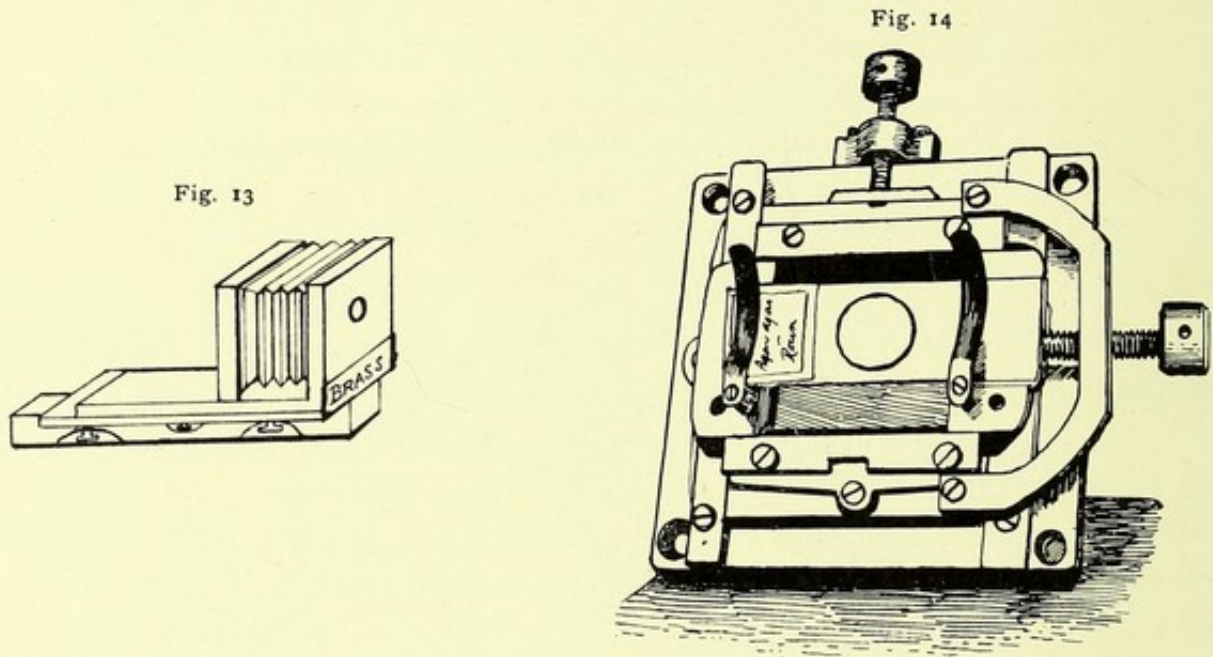

comfort obtained by its use, and the time saved thereby, must be experienced to be believed.

Before quitting the manufacture of apparatus, let another board be made about two-thirds the length of Fig. 12, p. 24, to place on the studio stand when required. This should have *no* support for the object, but should have two levelling screws, one at each end, for purposes to which we shall refer very shortly.

Development of the plate is considered in the next section.

Before quitting this portion of our subject, we must mention another department of low-power work which of recent years has been much in demand; we refer to photographing the culture-tubes used by Bacteriologists at about 1 to $1\frac{1}{2}$ diameters, as it is a department almost unique in itself.

Photographing Culture-Tubes.—These tubes in themselves are nothing but test-tubes of about $\frac{3}{4}$ to an inch bore filled to about $\frac{1}{3}$ of their extent with some

nutrient medium stiffened with agar or gelatin. They commonly present two varieties, viz., "stabbed" and "streaked" cultures. In the former the medium is solidified whilst the tube is held in a vertical position; in the latter when it is almost horizontal. In stab-cultures the growth is seen down the *centre of the medium*, in streaked cultures along its *inclined surface*. The difficulty in photographing them lies in the fact that

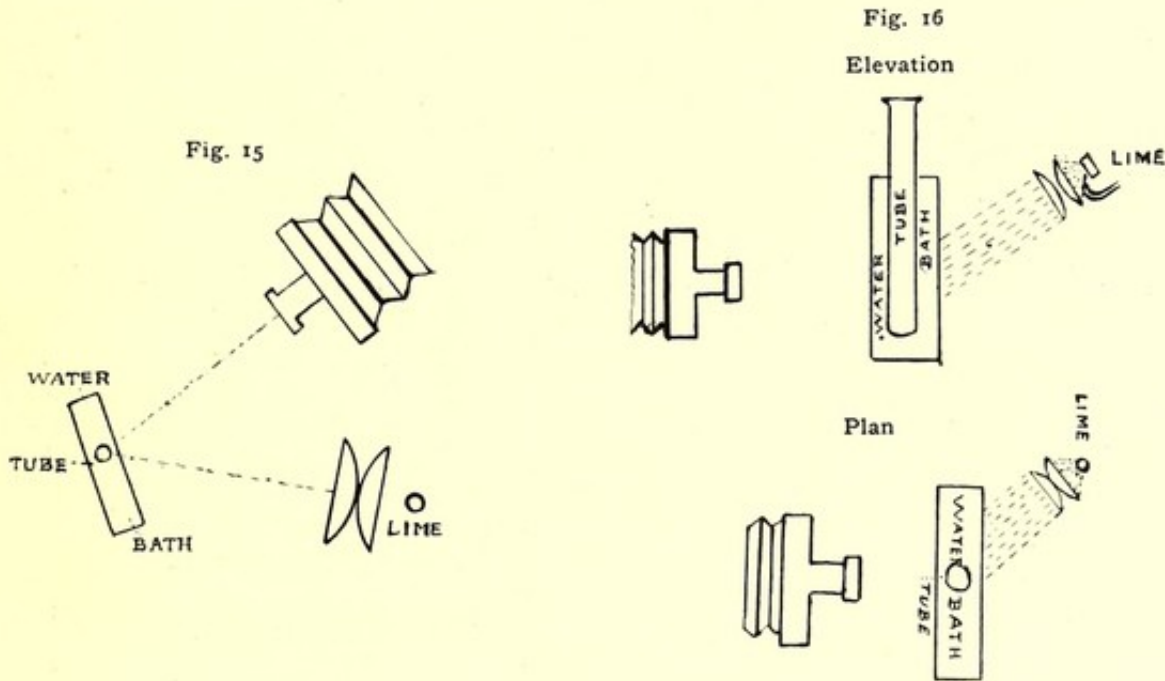

the glass walls of the tube reflect so much light as to spoil the final appearance of the picture. To avoid this it is best to place them in a large water-bath filled either with water or water and glycerine, the object of so doing being to entirely, or anyhow very largely, do away with reflections of all kinds. The lens we have found most suitable is a Ross Goertz or an anastigmat of about 5 inch focus, using the ordinary $\frac{1}{4}$ plate camera.

The arrangement as previously described (Fig. 13) should now be placed on the extra slide with rails (that we suggested should be made), as it enables the photographer to obtain his picture with comfort, for the camera slides to and fro with ease and axial precision. The use of the levelling screws mentioned is now apparent, for by them the photographer can adjust small irregularities in the verticality of the tube without the necessity of touching it in its bath. The position of the lime and condenser are shown in the diagram, Fig. 15. The exposure, when

employing an isochromatic medium plate by Edwards, well and evenly backed, is about 30 seconds at F/32.

When transmitted light is required the illuminant should be arranged as given in Fig. 16, where elevation and plan are both shown. That is, it should shine obliquely on the tube from above downwards. It is best so to arrange the light that parallel rays issue from the condenser upon the water-bath, which is done by pushing up the lime quite close to the condenser, in point of fact, to place it in its focus. Approximately parallel rays will then issue from the lenses. The water-bath must not be too small; about 4 inches long, 2 inches wide, and 5 inches deep are convenient dimensions. As a water-bath of this size is not a commercial article, but can be readily made, the following instructions for its manufacture may be useful: Procure two glasses of the correct size, some solid vulcanite (2 inches thick), cut in lengths to form the bottom and sides. Cover each surface of the vulcanite that comes in contact with the glass, as well as the surface of the glasses that come in contact with the vulcanite, with Miller's cement—procurable at any optician's—and firmly press the glasses on to them. Leave to dry for twenty-four hours. Now cut narrow strips of good strong paper, and apply them over the points of union of the glass and the vulcanite inside, and having coated them as well as the glass and vulcanite with cement, again leave for twenty-four hours. After becoming dry, apply one or two more coats over the joints with the same cement, and all will be complete. To make it more handy and to prevent being easily upset, it is well to arrange a wooden support to take the bath as a whole.

With streaked cultures the tubes must be inclined at such an angle that the level of the obliquely inclined medium is approximately at right angles to the optical axis of the lens, by which means it will be found the upper and lower ends of the gelatin inside the tube can be photographed at one plane of focus. It will now be seen why it was necessary to make the water-bath so wide; it was to allow of this tilting.

Another variety of tube, which the bacteriologist may require to have photographed, has not yet been referred to, namely, the bubble-tube of *Bacillus coli communis*, or that of *B. œdematis maligni*—*malignant œdema*. Such tubes contain bubbles of gas which, arising in the substance of the medium, pass through it towards the top. It is no easy matter to take a good photograph of this type of tube, unless the light is placed almost in a line with the lens on the other side of the bath, a piece of ground glass being placed between the condenser and the water. The photographer is reminded to be careful not to focus the ground glass—let him keep it near the condenser.

As our desire is to make what we say essentially practical, a few hints must be

given regarding the method of supporting the lime and the condenser. As the light is to be raised vertically up or down to get the required obliquity, so the lime must also be tilted with the condenser to allow the issuing rays to fall upon the tube fixed beneath in its bath. We have found that a convenient arrangement for this tilting is afforded by fixing the tray of the jet upon a piece of wood which is hinged at its ends to another piece, as shown in Fig. 17. A simple wedge is now all that is required to raise or lower the end of the upper board, so as to make the rays tilt enough to impinge on the tube. To make our meaning clear, we may say there are really two movements required; one to raise the light above the object, the other to

Fig. 17

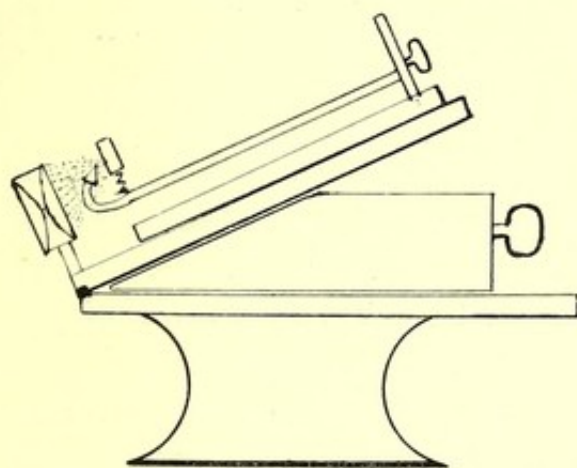
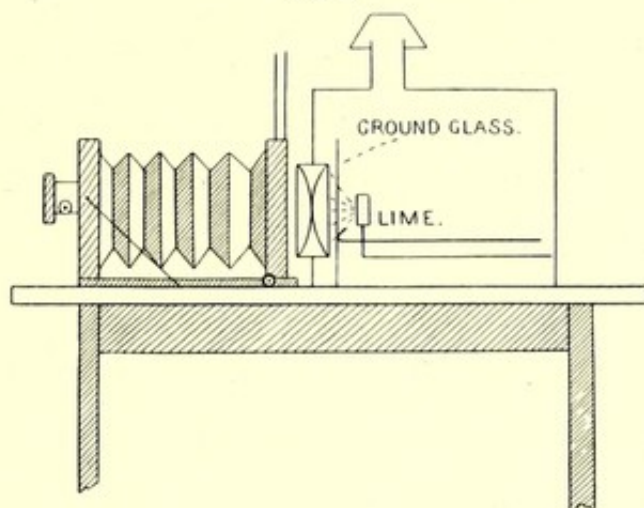

Fig. 18



tilt the condenser sufficiently down to bring the rays obliquely on to it. The arrangement is shown in Fig. 17.

In taking this class of photographs it must be distinctly understood there is no hard-and-fast rule; each position that we have explained must be tried by direct experiment until the results required are obtained. Occasionally troubles may arise from bubbles forming in the water-bath while the apparatus is being got in order. These must be carefully looked for at the last moment before taking the photograph, as it is annoying to find afterwards that their presence has spoilt the final effect. A pencil or stirring-rod is useful for this purpose, and should always be handy.

If water be used, and not glycerin, it rapidly becomes hot if much time is spent arranging the details for taking the photograph; this, too, should be carefully guarded against, as with some tubes the slightest heat will melt the gelatin and

spoil the tube. It is necessary, therefore, to have quite close at hand some cold water to instantly add to the bath, for the slightest delay has, in our hands, on one or two occasions produced the very disaster we wished to avoid.

Another hint to remember is to cleanly wipe out the water-bath each time after using, for if water be left in it when not in use it will slowly evaporate and leave ridges of stain on the inside faces of the glass, which have in our own experience given rise to considerable trouble to remove. (We have found that spirits of wine or very dilute hydrofluoric acid, about 20 drops to the ounce, the best for this purpose.)

A difficulty arises sometimes when photographing the obliquely filled streaked culture tubes from condensation within the tube itself. This constitutes a most formidable trouble, and one which on some occasions we have been unable to avoid. If leave be granted to move the paraffin wax and woollen plug—to do which gently insert a slightly warmed penknife around the wax at its contact with the glass—the best plan for getting rid of this annoying trouble is to take a stiff roll of blotting paper of the thin filter-paper type, and very gently insert it down the tube. One touch of the culture may spoil it hopelessly, so the treatment requires the greatest of care, and, as before stated, should never be done without the leave of the bacteriologist. It should be recollected, too, that, if the growth be touched, the paper should be at once immediately burned and the wool and wax returned to their place, recollecting to put the wool in first, and then the melted wax seals up the tube.

Examples are given of this kind of photography in Plate V., which are by the kind permission of the publishers taken from the "Atlas of Bacteriology," of which the writer is joint author.

Enlarging from the Primary Negative.—Occasionally an original negative may have been taken too small to satisfy the requirements of its owner, and so requires enlargement—a remark that applies to photo-micrography in all its branches; hence we think it advisable before proceeding further to explain how this can be done very easily if only a few copies are required.

For example, let it be supposed that a low-power negative of a spider has been taken to fill a lantern-plate and it is required to enlarge it from the negative so as to fill a page of this book. The arrangement is shown on page 29 (Fig. 18), where it is seen the large condenser and limelight are again used, but the camera is reversed in position.

The light will now pass through the negative first (the plane side being turned

towards the condenser), and after that through the lens, which should be of about 6-inch focus, or more will not matter. There is no lens in our experience, after absolutely trying several kinds, save one of the new anastigmatic series, equal to an old-fashioned triplet by Ross or Dallmeyer, which can often be purchased second hand for a few shillings. If it can be had with rack and pinion it is all the better.

The photographer now pins on the wall a piece of plain white paper and projects the rays on to it. If his dark room is not large enough for this purpose, he must convert a sitting-room into one, but this necessitates his waiting until night-time, and also requires him to possess some powerful form of dark-room lamp. If such be not at hand he can arrange an excellent "make-shift" in the following manner: Obtain an old champagne box and fit over the front a piece of red glazed calico, sold at any photographic dealer's; also purchase a gas-burner with tap, having attached to it a piece of rubber-pipe tubing of sufficient length to fit on to the gas-pipe of the apartment. A little hole in the back or bottom of the box (covered with a loose-fitting piece of red calico) is now to be made, through which the gas can be ignited with a taper. He must also purchase two iron elbows about $1\frac{1}{2}$ inch diameter, and having fitted one into the other thus  fix one end by means of a common socket to the side of the box, *that side which when the box stands on end will become the top*. These allow the fumes to escape, the gas bracket being fixed to the opposite side, *that side which is to be the bottom of the lamp*. Night having come, he focusses the specimen carefully on the piece of paper pinned to the wall, which is then removed, having carefully marked its exact position on the wall. The bromide paper, upon which the enlargement is to be made, is then taken out of its packet, the light of the lantern being turned nearly out *pro tem.*, whilst the extemporised "ruby" lamp is turned up. A piece of deep yellow glass is then fixed over the lens or held there by an assistant whilst the photographer turns up the limelight to see if the *position* is quite correct. Yellow glass will be quite enough to prevent the lime-light from acting on the paper, and red we have usually found too dense. The focus had better not be touched, even though it appears to require it, for the yellow glass often seems to spoil the sharpness of the image on the screen. He now removes the coloured glass and exposes, if with Ilford Rough Rapid Paper for about three minutes at F/16 and mixed jet at full work.* Development by ferrous oxalate is the cheapest, but some prefer amidol. Hydrokinone may also be used, but the matter will be referred to again later when development as a whole is treated.

* Of course this will vary in accordance with the amount of magnification and the density of the negative.

Before quitting the subject, occasionally the photo-micrographer may be asked to produce very low-power photographs of **Pathological Microscopical Specimens** which are *violently* stained in contrast colours of which red is often a large component. If these be photographed by the ordinary methods it will be found the resulting prints are full of the most severe contrasts, the red-stained portions coming out violently black if the rest of the print be *fully* developed, whereas if under-developed to render this less pronounced and to show details which really do exist in the negative in the red portions, the rest of the structure appears *faint and ill-defined*. No amount of "shading in" (described later on) of the negative will cure the trouble. To render a more uniform photograph resort must be had to the power which exists in the hands of the photographer to *lessen* contrast: viz., he must use a glass of the same colour as the predominant colour of the specimen. If, for example, it is one of those specimens where red-stained blood-vessels or other tissue abound and are so troublesome, he must reduce the severe contrast by employing a red glass of light density or otherwise, which will *increase* the exposure for the parts not red, whereas it has but little effect on those so stained. In other words a more balanced negative will result. To take such a photograph he must, it need scarcely be pointed out, use a red-stained plate such as a Cadet Spectrum, Lumière's Panchromatic, or red and yellow plate. He must develop too in the dark, only glancing at the picture by fits and starts for a second at a time, with a very subdued green light if possible. Having then produced a flatter negative, but one full of detail without such violent contrast, he had better print it either by the platinotype process or in bromide which will be spoken about hereafter.

SECTION II.—(i) DEVELOPING THE NEGATIVE

Before developing the negative it is necessary for the photographer to have a dark room of some sort. We do not propose to dwell at length upon this matter, as it seems unnecessary in a work of this nature. A dark room should have water laid on with a sink and waste-pipe, a means of ventilation and also three shutters, two of red fabric and one of yellow, effectually shutting off the light of a fish-tail burner which should always be placed *outside* the apartment. All bottles should be distinctly labelled in large letters so as to be easily read in the subdued coloured light. Developing dishes too should be near the sink and so quickly at hand; covers to them also, made of light wood, should be provided *especially when working with isochromatic plates*.

Each photographer has his own pet formulæ for development, but the following,

known as Thomas's Hydroquinone formula, we have always used with the greatest satisfaction for the class of work under consideration :

SOLUTION I.

| | | |
|-----------------------------|---------------|----------|
| Hydroquinone | 160 grains or | 8 Gm. |
| Potassium bromide | 40 " " | 2 Gm. |
| Citric acid | 60 " " | 3 Gm. |
| Water to | 20 ozs. " | 440 C.c. |

SOLUTION II.

| | | |
|----------------------------|---------------|----------|
| Sodium hydroxide | 160 grains or | 8 Gm. |
| Water to | 20 ozs. " | 440 C.c. |

SOLUTION III.

| | |
|-----------------------------|------------------|
| Potassium bromide | 1 in 3 of water. |
|-----------------------------|------------------|

It is our practice to always take two negatives of any object, each having a little different exposure, and to develop both in a half-plate dish at one time. For this purpose 6 fluid drachms of Solutions I. and II., and 6 drops of Solution III. are taken, filling up to 16 fluid drachms with water.

The prudent photographer will always periodically test his dark room to see if the fabrics (or stained glass if he prefer it) still maintain their proper qualities. This is done in a simple way as follows :

A plate is put into the dark slide in total darkness, and the gaslight then turned on. (It is a convenience to have the means of doing this from the *inside* of the room.) The shutter of the slide is now partially drawn and the plate exposed about $\frac{1}{2}$ inch for, say, 10 seconds ; another $\frac{1}{2}$ inch opened, the plate is further exposed another 10 seconds ; a little further and another 10 seconds until at length the whole plate is exposed *all but a small portion*, which should be kept intact as a check against the appearances presented by the other portions after development. This process should be of course carried on for a given time in *absolute* darkness and the plate washed and placed in the "hypo" without turning up the light. The plate is afterwards examined and *should* show no difference in any part. If it does the difference of time required to produce the fogging shows the severity of the "leak."

To develop the two plates of which we have spoken, the developing solution is thrown over them in one sweep so as to leave no irregularities on the plate ; which inevitably occurs if by any chance one portion of the emulsion is covered with solution a longer time than the rest. The dish should be violently agitated from *side to side*

to make this equality in the distribution quite certain. The plates must be covered during the whole process of development (especially the isochromatic ones) and the three-coloured window well closed whilst the plates are put into the slide and during the first portion of development. To obtain perfectly clear and clean unfogged negatives with his isochromatic plates, Mr. Edwards quite rightly insists on the necessity of having a dull red light and, moreover, that the plates shall be well covered. When "backed" plates are used—and we believe that every plate, whether for landscape work or photo-micrography, should *always* be so treated—it is best to wipe the backing off before placing in the developing dish, and we have found it a handy plan to have a piece of rag kept in the sink in one place for that especial purpose.

All during development the dish should be rocked to and fro and from side to side, the negative being looked at as little as possible, and then only for a moment to note how the process proceeds. After about a minute or a minute and a half—a longer time in winter—the image commences to appear on Edwards's iso-medium plate, the bright parts of the original object of course showing first and the details following after. When these begin to become apparent, say after about five minutes, one or two of the shutters may be opened and the negative somewhat carefully examined, especially the back of the plate.

If during development the picture "*rushes up*" with great rapidity, it is sure to have been over-exposed: at once put in the developer two, four, up to twenty or even thirty drops of the Bromide Solution according to the rapidity in question. Here most decidedly practice is needed. Always develop until the image is well seen on the *back*, and let it be remembered as a guide that if the image comes through very quickly the plate is *under* exposed; if slowly and steadily, *rightly* exposed; if it hardly will come through at all, *over* exposed.

Developing a negative is an art, and cannot easily be written about because it is impossible to find words exactly fitted to describe the different appearances. For this division of our subject what we have said seems sufficient, but as development of *medium*-power work and *high*-power work each offer certain peculiarities in themselves, we shall refer again to the subject a little later on.

After washing the negative it is placed in the "hypo" bath as it is called, a dish containing hypo-sulphite of soda dissolved in water. The exact proportions of the crystal to water does not seem to matter, but a too concentrated solution works very slowly, almost as much so as a too diluted one.

After leaving in the "hypo" for a little time all the yellowness of the plate is dissolved out and the negative is said to be "fixed," as light will have no further

effect upon it. It is always well to leave negatives in the "hypo" a few minutes—say five—after they appear to be "done," as there are good grounds for belief that they keep better in the future if such a plan be adopted.

As regards drying the final negative, we have had so much trouble caused by inequalities in the film, produced by irregularities in the drying, that some time ago we gave much attention to the subject, and seeing that now hardly any trouble in that direction arises, we venture to simply state how it may be avoided.

The negative is placed glass side downwards on a cloth and a fine handkerchief is gently and neatly laid over the gelatine side. It is smoothly and firmly pressed with the hand for two or three seconds, which allows the fabric of the handkerchief to absorb all the superficial moisture. On raising the handkerchief it will be found that the gelatine shows distinct marks of the fabric. This is not of the slightest consequence, for it absolutely and entirely dries out of all existence.

The back must now be carefully wiped—one source of trouble arises entirely from drops of water accumulating there, thus causing an unequal distribution of temperature in the whole plate. A ring of slightly melted gelatine will often be the result, which it is needless to say spoils the picture. This is especially the case when the negative is dried on a hot water tank.

Having superficially dried the plate in this manner, all that is necessary is to separate it from others at least by an inch, for if this be not done what is left of the moisture in the gelatine film of one plate will condense on the back of the other, and this condensation in due course will collect into drops, producing the same effect as if the back of the negative had not been wiped.

With respect to developing the *enlargements* to which we have referred, a few words must now be said. Oxalate of potash is by far the best developer for large work, as it is much cheaper. It must be very concentrated and mixed with the iron solution just before use in a manner and in proportions fully set forth with each paper that is upon the market.

Of these there are several brands; the one which we have used for single enlargements even up to three feet in length from $\frac{1}{4}$ -plate negatives, is the rough Ilford Rapid; but for fine work such as the reproduction of prints from negatives, where fine details exist, like that in diatoms or bacteria, the paper is not suitable; "Nikko Paper" is the variety to employ for this purpose, but to that we shall refer a little later on.

(ii) MAKING LANTERN SLIDES

We next proceed to explain how to make lantern slides from the negatives obtained photo-micrographically. Plates ready made are sold by most makers, and each claims superiority of manufacture. They are primarily of three kinds: ordinary gelatin, printing-out gelatin, and collodion. Of these the gelatin are by far the easier to work, as they possess much latitude in exposure, whereas the collodion type, whether ready made or manufactured by the photographer himself, must have exactly the right time given them, or they are of no use.

With respect to plates made with gelatin emulsion, they may again be divided into rapid and slow. It is not easy to define accurately the advantages or disadvantages of either, but speaking generally the rapid type give black images, whereas the slow are more amenable to treatment and produce pictures much more warm and soft. Almost any colour may be obtained with them if the directions enclosed in each box are carefully carried out. Then, again, if one is unable to obtain detail known to exist in a negative with a quick plate, the prudent experimenter will surely try a slow one, and if unsuccessful again, try his luck with one of the printing-out type.

For the subject in hand—the production of lantern slides from photo-micrographically obtained negatives, especially in the case of medium and high-power work—seeing they are more dense, and require such careful exhibition of detail—and as there are many who consider that rapid emulsions give more gradation than slow ones—although this is not a universally accepted statement—so we have mostly found that the rapid series of lantern plates suit our purpose the better. As to the finest maker, we cannot be expected to advise, but what we use ourselves and can find no fault with are those prepared by the Paget Prize Company, the “Rapid” series.

Let one be placed on the negative as it lies in the printing frame, having first carefully examined its film to see that no little pieces “stick up” from the edges—an attempt at “frilling” of the plate. If these bits are present they will be found to be very hard, and will resist the accurate contact of the lantern plate against the film of the negative so effectively as to prevent the best result being obtained. Let them be scraped off with a sharp knife. Seeing that the lantern plate lies in sharp contact then, the frame is held in front of the gas flame at a distance of a foot, taking care to move it about as mentioned when explaining a little later on the exposure of Nikko paper. A good negative of the proboscis of a blow-fly will require about five seconds; ten will not hurt it, as there is so much latitude with these lantern

plates. This ended, remove the plate and flow over it a developer consisting of equal parts of the hydroquinone and soda solution, which happens to suit the emulsion admirably.

In a few seconds the positive will commence to appear, growing in density and definition with exceeding rapidity. Attaining sufficient definition and blackness, the developer is poured back again into the measure (for it can be used over and over again, as when using it for Nikko paper), and the slide allowed to drain for two to four seconds, when it will be found to grow distinctly foggy. Wash quickly and sharply—not losing much time, as development is apt to go on notwithstanding the washing—and plunge into the hypo bath, which is of the same strength as that employed for fixing negatives.

In a few minutes—a much shorter time than that required for fixing negatives—the positive image will appear quite free from yellowness. Let it rest in the bath for a few minutes longer than appears actually necessary, just the same, only for a shorter time, as was recommended when dealing with negatives. If now the background appears perfectly transparent and the image bright and black, the operator may be satisfied, but if brown it has been over-exposed. Try half the former exposure. If, on the contrary, it is everywhere faint and shows lack of detail—the hair points hardly out and the edges of the suctorial tubes deficient in continuity—the time before the gas has been too short—remedy: double it.

But should the slide appear with a muddy ground, so very common and so very unsightly, one of three faults have caused it. Either the negative is too thin—remedy, intensify it in a manner to be yet explained—or the slide has been over-exposed or over-developed. To ascertain which of the three, first look at the negative. If too thin the gas-flame will be too easily seen through it. If the fault is over-exposure of the slide, try less; and if over-developed, do not be so slow over the process. Suppose, after trying again, the background of the slide still appears dirty-looking and overcast, then glance at the original specimen and note if the mounting medium is clear or yellow. If yellow, there is no remedy but taking a fresh negative with more exposure. But here we may be confronted with a most troublesome difficulty. Suppose a more exposed negative is taken and we find on development that the background is sufficiently dense and black so as to produce a clear, clean positive, but at the same time the proboscis itself is much over-exposed, all its details being choked up with deposit. Thinning will be of no service because we shall thin the background at the same time as the proboscis, and the final result will be the same as if the whole negative had been exposed for a less time. We are

prepared to admit the difficulty is great, but it can be very often got over to a great extent in the following manner:—Consider the circumstances: a yellow interceptive background from the colour of the mounting medium, which increases the exposure, and a brilliant proboscis, which has only absorbed enough of the yellow mountant to clear it and make it more transparent. An increase of exposure has been found to increase the density of the background, it is true, but at the same time to cause over-exposure of the proboscis itself. The only way we know of is to use a glass screen of some colour to render the contrast in exposure less severe. A green pot glass, about one eighth of an inch thick and of medium density, will increase the total exposure, it is true, some five or six times, but will often produce a more equally balanced negative. Sometimes we should prefer a yellow screen, and with certain specimens obtain a still better result. Let the photographer try the effect of each colour and judge for himself. When the contrast is not pronounced enough, as often found with specimens of bacteria, exactly the opposite treatment is required, and a glass is used to increase it.

The lantern plate should be washed after leaving the hypo for at least an hour, and then be dried on the hot water tank, after having wiped the back. We do not find wiping the front of any lantern plate a good thing to do. It is very useful in the case of negatives, but with lantern plates certain markings sometimes occur if the fabric be too severely pressed on to the emulsion.

We should like to mention one more matter, which gave rise in our hands to a large amount of trouble and experiment, and which will occasionally occur in warm weather with these and other lantern plates. We refer to a distinct and fatally pronounced yellowing of the clear portions of the film, which shows itself after fixing. It seems to resist all treatment, and it was a long time before we could ascertain the cause. At first, common hypo was thought to be the cause, and that the yellowness was only due to imperfect fixation. This was ascertained to be an error, and all the solutions were alike called to book for the trouble. The emulsion was then blamed, and the manufacturers called upon to explain. After a very considerable time was spent, and after the most courteous attention of the Paget Company was well-nigh exhausted, the trouble was discovered to arise from a staining by the developer when the process was carried on too slowly, and to an insufficient subsequent washing before fixing. We never get the trouble in winter, but even now, though rarely, come face to face with it in summer. Considerable soaking in water after development will remove it, but it is better to expose a little more, risking a browning of the final image, which will occur from over-exposure with lantern plates as with Nikko paper.

The slide is mounted by binding it against another slip of glass the same size, a mask of paper of suitable shape being interposed to prevent the film touching the surface of the opposing plate.

The "printing-out" slide needs but little description. It is made with a very transparent emulsion, and is placed in the frame and exposed to artificial or other light like an ordinary piece of printing-out paper. One side of the frame can be lifted, and owing to the transparency of the film the depth of printing can be easily estimated. The subsequent processes are fully set out in the printed directions with each box, and need not be narrated here.

With respect to collodion plates, the best ready-made ones we know are sold under the name of "Hill-Norris Dry Collodion Lantern-slide Plates." They require about a third more exposure than the rapid Paget we have described, and they may be developed with the same hydroquinone and soda solution, as it suits them very well. Great care is necessary in the use of the plates by contact, as the film is so delicate the slightest touch will scratch them. They also require the most exact exposure, as they flash up in development to a certain pitch which can never be made deeper or more dense by any length of development. They have the advantage, however, of being able to be fixed by a watery solution of any strength of cyanide of potassium, which does its work immediately and only requires a few seconds' washing to remove. They can be dried, too, in front of the fire or over a spirit lamp with impunity in a few minutes.

Seeing, however, so many collodion slides are made by the so called "wet-plate process," we feel it would be an omission on our part if we neglected to mention how these can be manufactured by the photographer himself.

It is first necessary to obtain what is called a bath and dipper, which can be procured for small-sized plates very cheaply. Into this is placed a solution of re-crystallised nitrate of silver from 40 to 60 grains to the ounce of distilled water. The glass plate to be used should be first most scrupulously cleaned both sides, and this must never be neglected, for if so the penalty paid for the mistake will be a severe one—the film will float off after its development, or after it is fixed in one or other washings.

To make this less likely we have always adopted the following plan in times past, when we freely used the wet-plate process for negatives, even on the field. It is to pour over the plate a preliminary coating of albumen in some form. There are many formulæ, but the one we used was always effectual, easy to make, and kept well. The solution was made by mixing 1 part of white of egg in about 500 to 700 parts of

water, to which was finally added 3 or 4 drops of commercial carbolic acid. The plate carefully cleaned with spirit and water and plenty of rubbing. The albumen solution was poured over it, several plates being done at one time, and drying was afterwards effected spontaneously in a dust-proof cupboard. When coating these plates with the bromo-iodised collodion, each one is held in the left hand, whilst the right one is occupied with pouring the collodion from its specially-capped bottle on to the centre of the plate in a little pool. The plate is tilted so as to flow the collodion in one wave—and only one—all over it equally, the surplus being quickly returned to the bottle, which is instantly covered. The operator is careful now not to incline the plate more in one direction than in another, or there may result a crease from this cause on the film. Presuming he accomplishes this satisfactorily, he watches for the material to “set,” and just when it has—let him try the edge at one corner to make certain—he places it into the silver bath, resting it on the dipper. When on lifting the slide out he sees no greasiness of the film, which is generally effected in about three minutes in summer and six in winter, he places it on the slide, which, by the way, should be made for wet plates, having silver wire corners. It is needless to say contact is out of the question, so all transparencies of negatives must be taken with the camera and lens, the limelight condenser already explained being used if daylight, which is much quicker, cannot be utilised. Development with one of the many formulæ is carried out in the usual manner, great care being exercised in pouring the fluid over the plate to do so with one sweep of the hand. The following recipe is a very good one :

| | |
|-------------------------------|------------------|
| Ferrous sulphate | 10 grains. |
| Glacial acetic acid | 15 minims. |
| Alcohol | 15 to 20 minims. |
| Water | 1 ounce. |

As the silver bath gets old—more and more silver crystals being added from time to time to keep up its strength—more and more alcohol is required in the developer to make it flow evenly. This hint should not be forgotten.

Washing, fixing, and drying are carried out in the same manner as with the dry-plate collodion plates.

As all collodion films are so tender every lantern-plate must be varnished. Rouch's transparent variety for wet plates we have always found to be excellent, but most wet plate dealers supply varnish equally good.

If the slide after development appears rather flat, intensification may be resorted

to, and this is done at once by pouring over the film some of the following, to which has been added a few drops of silver nitrate dissolved in distilled water (about 2 per cent.):

| | |
|---------------------------|-----------|
| Pyrogallic acid | 2 grains. |
| Citric acid | 3 grains. |
| Water | 1 ounce. |

After fixing, intensification may also be performed, but the solution is different and the effect very often prohibitive, as the film nearly always turns yellow or of an ugly colour. In our experience it is quicker and far more satisfactory to make another exposure rather than tinker with a lantern slide. With a negative it may be different.

The faults that may arise by this process are many. The following are the leading ones :

1. If the plate, after development, appears foggy in patches, probably the plate has not been properly coated with albumen, or is not clean.
2. If patches are transparent in bubbly-looking spots probably bubbles have been present, and so have prevented the plate being properly sensitised in the bath.
3. Streaks and irregular markings suggest a damp plate in parts.
4. Streaks all over and general irregularity in the film, some parts much more coated than others, usually arise from badly coating with the collodion, parts becoming drier than others before putting in bath.
5. Comets and pin-holes often come from dirt either in the collodion or on the plate.
6. Marks of deposited silver on the edges arise nearly always from a dirty slide.
7. Flat pictures nearly always mean a dirty bath. To remedy expose it to the sun and filter. Avoid a too acid bath, but equally so an alkaline one.

(iii) PRINTING POSITIVES ON PAPER OF DIFFERENT KINDS

Seeing that many may very possibly conduct their photography at evening time rather than during the day, we will describe first how to take a print on paper which can be exposed in front of the gaslight. We refer again to the excellent paper for all photo-micrographical work, namely, that sold under the name of Eastman's "Nikko paper." There is not space here to describe many varieties of bromide paper, but having tried most of them, we have found that ordinary bromide paper gives too

coarse a grain, and does not seem able to give the minute details which are readily shown with the Nikko. Taking a piece out of its case (of course in the dark room, one ruby fabric), we lay it face downwards on the negative placed in an ordinary printing frame. Advancing to a naked gaslight, with the face of the printing frame resting against the coat, we place it—the face of the negative—in front of the light at a distance of one foot, moving it in that plane up and down or in a circular motion, so that the bright part of the flame strikes upon all parts of the negative equally. If this be not done, it is very probable that the print will be unequally exposed, and the final result will appear uneven. One point must here be mentioned; it occasionally happens that a very good negative has been obtained so far as applies to the object, perhaps a most difficult diatom, but the light, through some oversight, or perhaps through a small portion of the lime spurting off during exposure, is not equal all over the plate, a most provoking occurrence; but it can, if not too bad, be readily remedied. Whilst exposing the print before the gas it is not difficult to hold a blackened card in such a manner as to shade the thinner part, whilst allowing the denser portion to be exposed. This requires a little practice, more especially to know how much more exposure the denser portion should have. Then, too, the card must not be held still but kept moving over the picture, otherwise a line of demarcation, hard and defined, will inevitably result across it at the junction of the covered and uncovered portions.

Having now exposed our print what we think a sufficient time (with a good negative of a proboscis it will probably only want from twenty to forty seconds), we at once return to the dark room, take out the paper, and immerse it in water, taking care that the whole of the paper is thoroughly covered. After a few seconds, say about ten, the paper will stretch itself out, and this indicates it is ready for the developer. The water is drained off thoroughly, and the print placed paper side down upon the dish. Equal parts of the hydroquinone and soda developer (see p. 33), (about half an ounce of each is sufficient for a quarter-plate print) are then flowed over it. After a few seconds, much quicker than in the case of the negative, a positive image comes into view. The photographer must keep his eye now fixed upon the picture and not let his attention be attracted to anything else. It should be developed till all the details of the image are well out, and then the developer instantly poured off and the picture allowed to drain for a few seconds, say three; in which interval, if he notices, he will detect a grey look coming over the whole print, which he is apt to think will spoil it. This is not so, for after washing well and placing in the hypo, such greyness entirely disappears, leaving a beautifully black

and crisp image. Perhaps, on looking at the picture, it may be brown, although it appeared most beautifully black in the dark room. This is mostly due to one fault—over-exposure; remedy, try half the time. If, however, there is still a brownness, although the print is evidently under-exposed, the operator has made some mistake in the mixture of the solutions or has forgotten to shake up the soda solution before using. It may be here stated that this developing solution can be used over and over again on the same evening, taking care to add equal parts of soda and hydroquinone to fill up the deficiency which will take place after developing each print. Browning or greying of the print which is properly exposed may sometimes arise from neglecting to keep up the strength of the solutions.

Having washed the print for fifteen to twenty minutes in running water it is thrown upon a piece of polished plate glass prepared as follows: Well wash first with soap and water to clean off all grease or dirt, thoroughly wipe with a clean towel and give as much polish as possible. Take a plug of wool, dip it in powdered French chalk, and rub over the surface of the glass, wiping off the superfluous amount with two or three, not twelve or thirteen, rubs of a handkerchief rolled into a pad. By this means it will be understood an *infinitesimally thin* layer of French chalk really remains upon the glass; if too little perhaps the print will finally stick; if too much the thick portions will leave little dents and ridges on the print. The print being taken out of the water is laid to drain for a few seconds, and then thrown on to the glass, being held gently by the first finger and thumb, a squeegee being passed over the whole, not with heavy pressure, however, or it may injure the delicate surface of the print, but with sufficient pressure to squeeze out the air between the print and the glass. Let the glass be lifted up and looked at in a strong light. No bubbles between the print and the glass should be seen. If there are the print must be squeegeed again; if not, it can be left six hours to dry. In winter it may need ten or twelve; in summer three or four, but no artificial heat of any kind must be employed; if it is, the gelatin surface of the Nikko will assuredly melt, and nothing but hot soap and water will remove it from the glass. When we wish to peel off the print take a knife and raise one edge, pulling the print rather than wrenching it off backwards. If cracked lines appear all over the surface it is because the paper has been bent backwards too much in pulling off. We mention this because it took us some time to find out the cause of the trouble. If it is desired to mount the print on a card it should be smeared over the back whilst wet on the plate with a solution sold by the Eastman Company for the purpose, such purpose being to prevent the moisture of the mounting medium getting through the substance of the paper, which

if it does, instantly removes all the polish. If, however, one is desirous of mounting a print that has not had applied to it the special mounting when wet, we may use a little strong solution of gum arabic, which will suffice for the purpose and answer fairly well.

As regards a suitable board upon which to mount Nikko prints, much depends upon taste, but we have usually found that a grey edging suits them better than a white, inasmuch as the Nikko paper nearly always has a slight tint of pink, although it may be procured absolutely white.

There are several, however, who think the best details that can be obtained from any negative can only be obtained by the use of the old-fashioned so-called "silver print," otherwise known as albumen paper positives. These are easily made but require daylight. The paper can be bought ready sensitised, but if the photographer desires to do this for himself it is easy enough. The best Saxe or Rives paper being procured, it is floated on to a solution of recrystallised nitrate of silver, about 60 grains to the ounce of distilled water. Having floated on this for about three minutes in hot weather, and about double the time in cold, the paper is carefully withdrawn so as to leave no bubbles on the surface, and dried in a dark place. Sensitising must also be done in subdued light. When dry the paper is placed in contact with the negative in the same way as when using Nikko paper, and exposed to diffuse daylight if the negative be a good one full of contrast and not choked in the high lights. If the plate has been over-exposed and is flat, subdued daylight is best, and on the contrary, if over-developed, being choked in all directions, nothing but direct sunlight will get through it. As half of the printing frame back can be lifted without disturbing the other half, so the paper can be examined to see how the print is getting on. It should be over-printed because the toning and fixing baths, into which it has to be placed, always reduce its intensity considerably.

When sufficiently printed, it is taken into the dark room (one ruby fabric enough) and floated in clean water; after a few seconds the water will become milky. Throw it away, and continue washing until the milkiness has all but departed. The print is then transferred to the toning bath. Of these there are no end, each photographer having his pet formula, many of which are to be found in the text-books. One that is very good for the purpose in hand is made as follows:

| | |
|---|----------------------------|
| Trichloride of gold | 1 grain. |
| Chlorineted lime (chloride of lime) | 1 grain. |
| Chalk | $\frac{1}{2}$ teaspoonful. |
| Water | 8 ounces. |

If the water be hot, the bath may be used when cold ; if not, a day should elapse between mixing and using it. This bath keeps well, but, of course, from time to time the ingredients must be freshly added. Another excellent formula, but which must be used on the day it is made, is as follows :

| | |
|-------------------------------|-------------|
| Borax | 100 grains. |
| Trichloride of gold | 1 grain. |
| Water | 10 ounces. |

This bath seems to suit the ready-made sensitised papers, to which we have referred, better than those made in the manner already described. Sixteen ounces should tone a whole so-called sheet of paper.

Printing with albumenised paper—although we practised it largely some twenty-five years ago—we have always considered an art, and many bad prints must be made before the amateur can expect to be perfect in it.

After the print is placed face down in the gold bath it should be turned the other way—face up—moved frequently, and watched. The colour which is rapidly imparted to it should be the same when the print is looked *through* as when looked *at*, for this will show the gold has permeated the film on the paper. Toning completed, another washing of the print is necessary, say, for ten minutes, before placing it in the fixing bath, consisting of “hypo,” 4 ounces, to water, 1 pint. Here it must be left for ten to fifteen minutes, or even longer, if the paper be very thick. Another washing—this time for not less than an hour—here follows, and the print is then ready for drying.

As many mistakes are easily made in printing with albumenised paper, and as these articles are to be as practical as possible, the following hints may be worth recording :

1. When sensitising the paper, if you know you have a weak, thin negative (usually arising from over-exposure and improper development), it is better to have a rather weak solution of silver nitrate, and to print in a feeble light.
2. Do not forget to wash the paper before and after toning, and at least an hour after fixing.
3. Do not try and economise by using a stale solution of hypo ; use fresh each time.
4. If your fixing is not a success let it remind you it is a good plan to test your fixing-bath before use, to see it is not acid. If so, add a little ammonia until neutrality is obtained.

5. Whenever you tone, wash, or fix your prints see they are kept well moving about and that there are no air-bubbles about.

6. Remember over-toning produces mealiness, and under-toning a reddish (brick-red) appearance.

7. Do not let any toning formula be too cold. Keep it, say, always about 60° F. and certainly not lower than 57° F.

Albumen prints cannot be polished in the same way as Nikko paper—at least, not without the use of a special solution: which in our hands is not often a success. If it is desired to polish them they must be enamelled. Solutions are sold for this purpose with full directions.

Printing-out paper may also be used for prints from photo-micrographic negatives, but they mostly have to be exposed in daylight. Full directions are given with these papers, which are made by several firms. We confess to have a special liking for that prepared by Otto Schölzig or by the Ilford Company. There is also an excellent class of paper sold by the Paget Prize Plate Company, called collodio-chloride, but it requires a little careful handling. Full directions are given with each packet.

CHAPTER III

MEDIUM-POWER PHOTO-MICROGRAPHY

IN this chapter the camera and its accessories with their suitable means of support are described.

Inasmuch as the apparatus used in this section, as well as in the next—critical photography—is the same, we must devote considerable time and space to describe it fully. Primarily it may be said to consist of a microscope with its attendant accessories; a camera, and an illuminant with the necessary means of support for the whole apparatus. But in *this* chapter, *the camera and its accessories with their suitable support* will alone be considered.

Inasmuch as the whole requires extreme rigidity, everything must be fixed with the utmost firmness on to a solid table having extra struts between the legs to keep it steady, and the legs themselves should rest on a concrete floor (or anyhow on four concrete supports isolated from the floor), so that any movement on the part of the photographer may not affect his apparatus. All this preparation for medium-power work may seem superfluous, but as it is an absolute necessity for high-power work, it had better be made carefully from the first. The precautions against tremulations of the floor cannot be too well carried out, and this is the better understood if the reader remembers that when photographing at 1000 diameters $\frac{1}{1000}$ th of an inch shake in the specimen *makes a shift of 1 inch in the photographic plate*. The heat generated by the limelight upon the microscope, too, is not a negligible quantity—for all metals sensibly expand with heat—and in the arrangement we use ourselves, to be described later on, is provided against by having a metallic shield to protect the microscope, when we don't use a water-trough, which screen has a hole in its centre only of sufficient size to permit enough light to pass through and fill the substage condenser.

The tremulations caused by passing vehicles is a source of never-ending trouble to the photo-micrographer, especially if he practises his art in a crowded town, and even

the most thickly concreted floor in a cellar beneath the level of the ground will certainly not suffice to entirely eliminate it. The best plan, where such troubles exist, is to adopt an arrangement such as is used by the "process block" engravers. It consists essentially in slinging the whole table, bereft of its legs, to two beams placed across the apartment. An upper room, instead of a cellar, can then be employed for the work, which is far more comfortable, seeing it can be warmed and kept free of damp. The details of this arrangement may be as follow: Each beam should be about 4 inches wide and 3 inches thick, both being placed above the head of the photographer, who thereby will save himself many a spoiled plate by an accidental jar against the beam, let alone an occasional ugly blow on the head.

Four pieces of rope about the thickness of the first finger or stout wire should be firmly fixed to each corner of the table, and be of such length that, when the observer is sitting in a chair at the camera end of the apparatus, the ground glass is on a level with the head. If the operator be desirous of making his arrangement as complete as possible, it is a decided advantage for the ropes from the table to pass over large wheel pulleys affixed to the beams, the apparatus being kept in equilibrium by four weights. The convenience of this addition is very great, because when the microscope is not in use a cover can be thrown over it, and the whole table pushed up out of harm's way. It has another advantage, that of always being ready for use without any preliminaries whatever. To complete the details, where rooms with wooden floors are used, and the apparatus slung, it should not be neglected to suggest that a little sand or water be kept within easy reach in an open bucket, to pour over any piece of incandescent lime which may perhaps break off and fall on the table, or more unluckily still, on the floor. Let it be remembered that treading on incandescent lime is not a safe thing to do, save perhaps with the heel; neither is at all times sufficient to put it out, and it may very easily cost the photographer a new sole to his boot, if not a burn on his foot. Let a cupboard with lock and key be also provided, and if the dark room be on the same floor it is a decided convenience.

As regards the purchase of the *apparatus itself*, not for the moment considering the microscope, its accessories or the limelight, but only including the camera, the focussing-rod and necessary base-board upon which the remaining apparatus can be placed, it is not easy to give selective advice. All the best firms of opticians make specially good forms, mostly, it is true, based on the same *idea of construction*, but nearly all differing somewhat in the actual details themselves. Space will not allow us to mention every one in the market, and if by accident any great omission on our

part is here made, it must be understood to arise either from the block of the firm's speciality arriving too late for insertion, or as a sin of *omission* and not of *commission*. Those that follow are arranged in alphabetical order. The first is that sold by Messrs.

Fig. 19

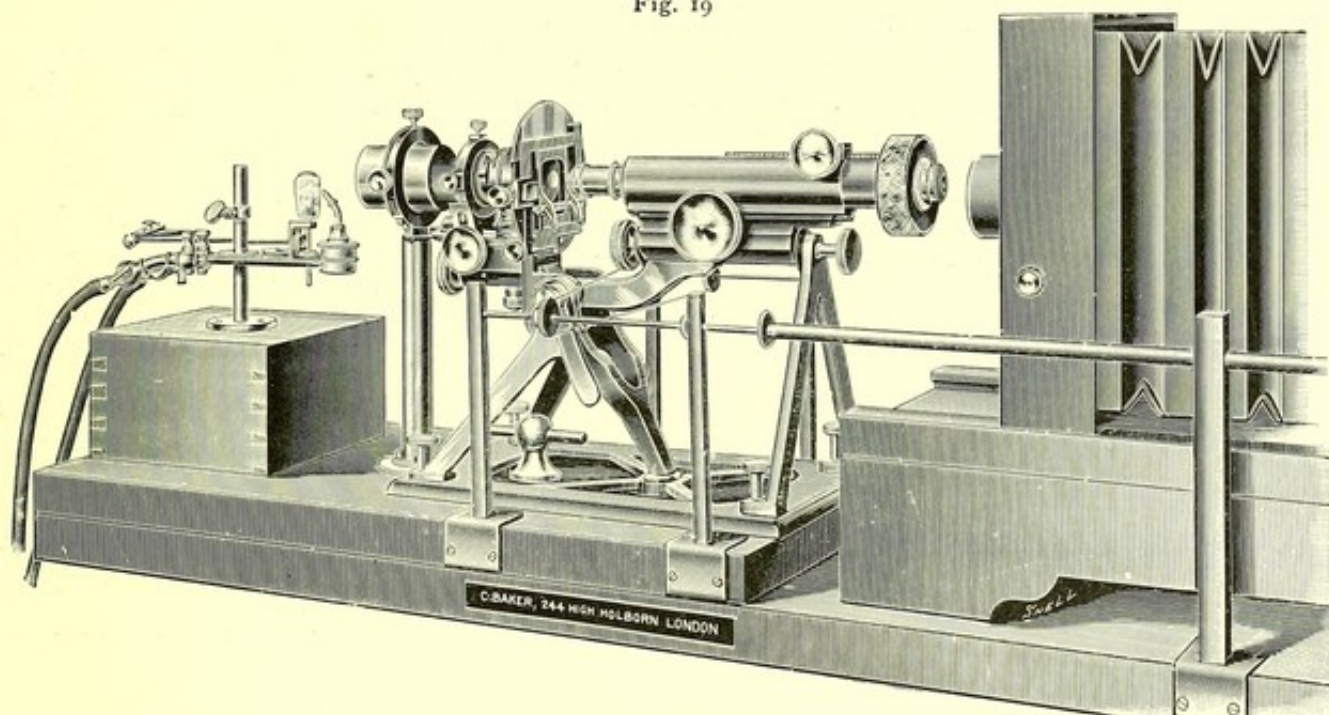
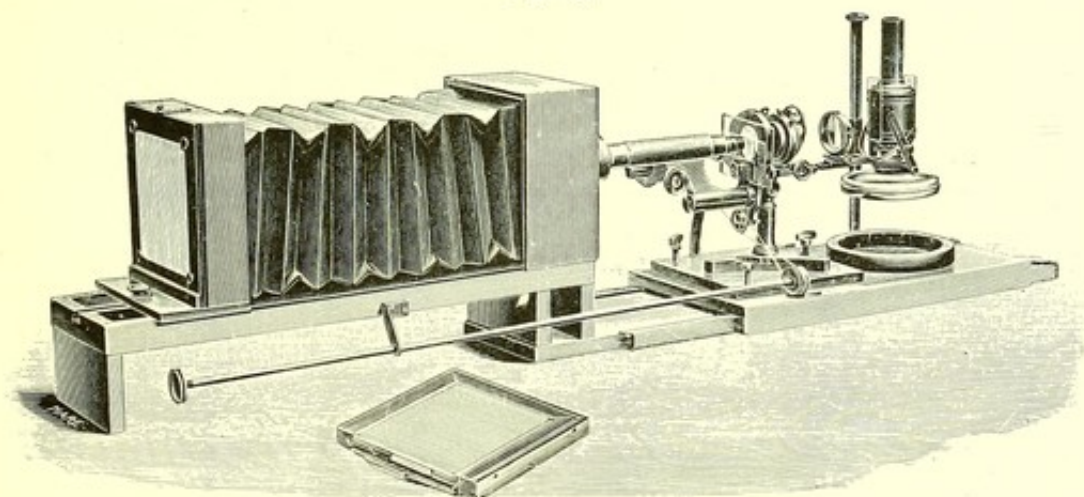

Fig. 19a



Baker, 244 High Holborn, a firm whose repute grows at an ever-increasing rate. Under the superintendence of Mr. Curties, who is himself a most able photo-micrographer of considerable experience, the customer may always rest assured of being courteously and considerately treated. No efforts are spared. The apparatus we

know well: it is excellent and in every way suited for practical work. Undoing the central screw the whole microscope with the illuminant shifts round on a turntable, which is of great service, supposing the operator has not searched his slide before commencing operations. At any time, however, it is useful. A long focussing-rod and camera (not all seen) complete the apparatus. It is shown in Fig. 19.

The apparatus sold by the old and esteemed firm of R. & J. Beck, of Cornhill, is given in Fig. 19a. As shown in the block it is arranged for low-power work, where the firm recommend the employment of an ingenious oil-lamp which is a *specialité* and shown in Fig. 19b.

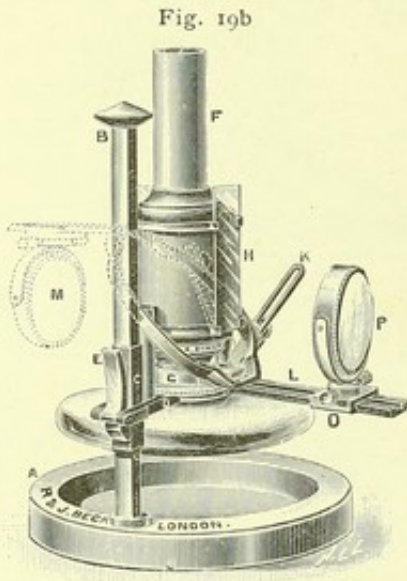

Another arrangement varying again in detail is shown in Fig. 20, originally suggested by perhaps one of the oldest and most respected fellow-workers in the subject—we refer to Mr. Pringle: it is made in a most excellent manner by Messrs. Swift & Son, and those who have employed it seem well satisfied. Being designed by so practical a man, it is needless to say all possible requirements of the photo-micrographer are well looked after.

The old-established firm of Ross & Co. also make a small but well-constructed stand. It is unostentatious and intended mostly for low-powers, being fitted for an oil-lamp, although limelight may be used. It is shown in Fig. 21.

Next we illustrate the form of apparatus sold by Messrs. Watson & Son, Fig. 22. Any transaction with this firm is always accompanied by great courtesy and attention, for the small wants of the beginner or novice are as attentively looked after as the requirements of the specialist or expert. The apparatus is devoid of all superfluities, which renders it, like that sold by Baker, of Holborn, very moderate in price. It is provided too with a means (not over-well shown in the block) for rotating the microscope and limelight without moving the camera. These manufacturers also sell another stand suggested by Mr. Stringer, and a student's form.

The last firm we mention is that of Zeiss: we gladly recommend them, for we have never received otherwise than extreme attention and courtesy at their hands. Their representatives in Margaret Street, Cavendish Square, are always willing to afford every possible information and take all the trouble they can in carrying out

the wants and wishes of their customers. The firm make a *most* excellent apparatus for extreme high-power work, which is known to have given excellent results. On inspecting Fig. 23, it will be seen that the arrangement is entirely on a different principle, for the camera is isolated *completely* from the optical apparatus. We know there are many photo-micrographers who doubt the expediency of the arrangement, but the whole is so convenient and so solid that we confess what the firm say themselves is very true: "that it should be tried first before being spoken about." Everything is of the highest quality, no trouble and care have been omitted to make all adjustments as perfect as possible, and those to whom expense is no object should call and see it before making up their minds. Although in the illustration electric light is shown, still the firm make it for limelight when ordered. It will be noticed that the accessories of the table all slide on the "optical bench" fashion, which is very admirable, a plan also adopted in Mr. Stringer's form made by Watson, about which we have already spoken; indeed, his stand in essentials is exceedingly like the Zeiss pattern, although the separation peculiar to the Zeiss model is absent.

As, however, all these forms are somewhat expensive, and as many feel

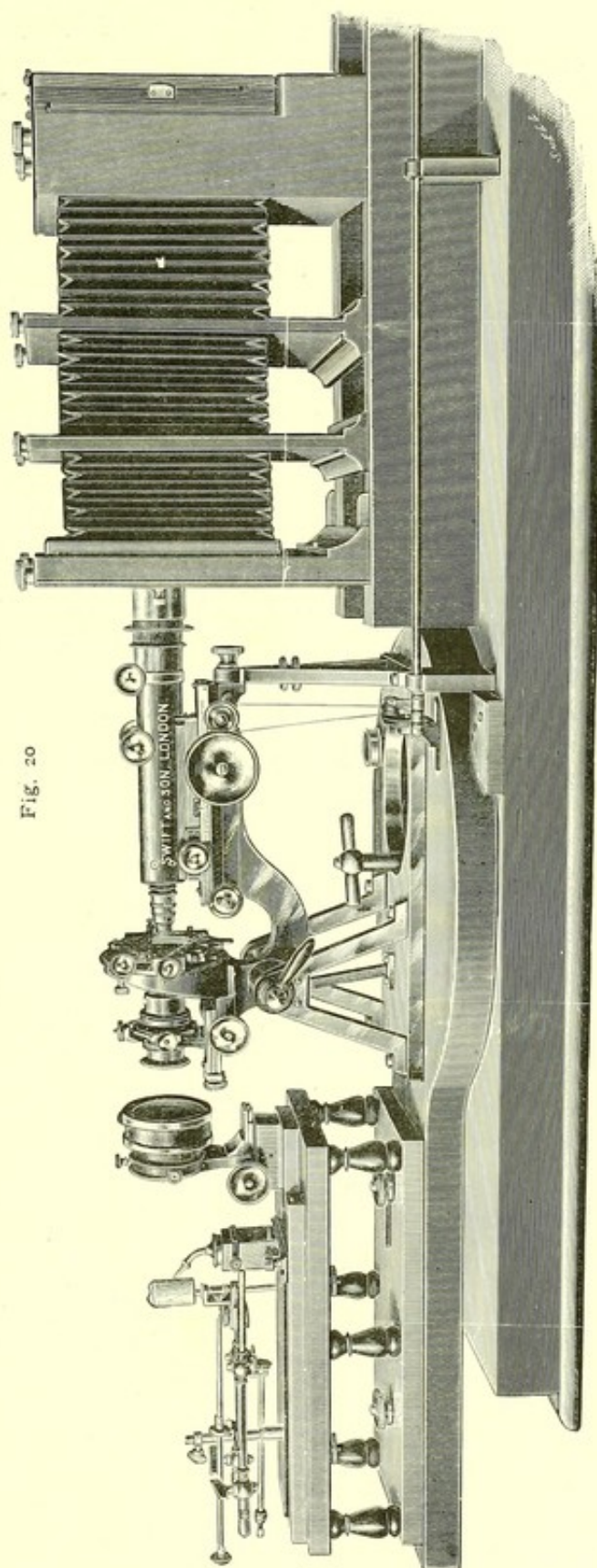

Fig. 20

PHOTO-MICROGRAPHY

Fig. 21

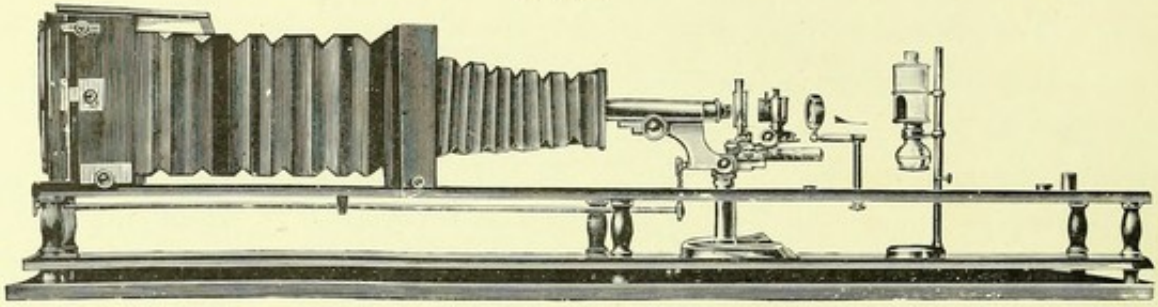

Fig. 22

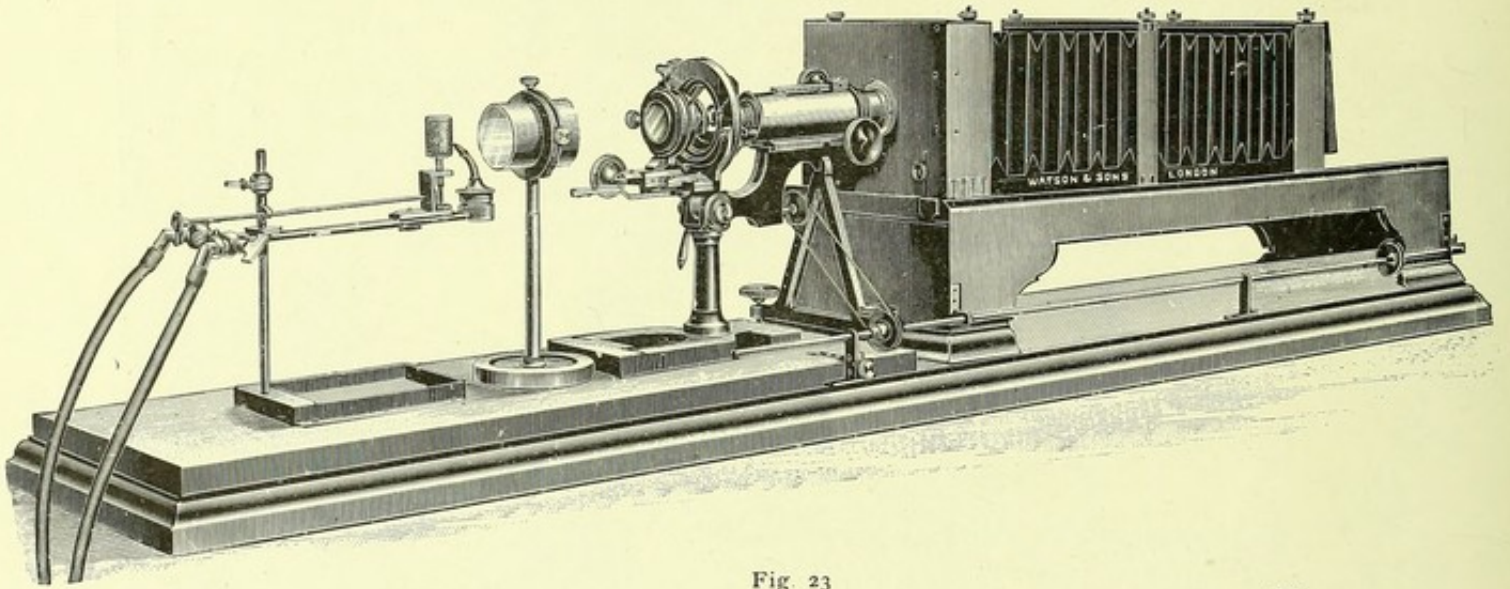
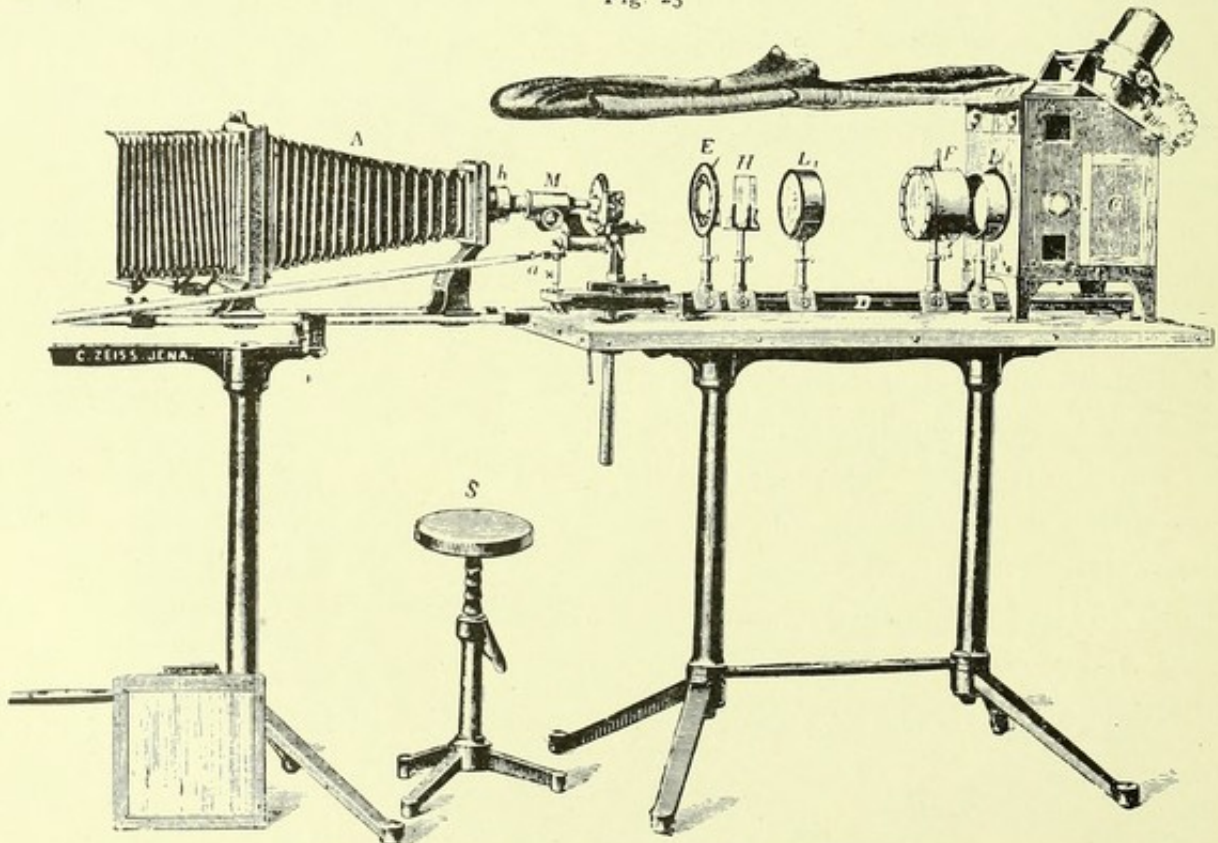

Fig. 23



Large Photo-Micrographic and Projection Apparatus

loth to enter on the subject of photo-micrography on account of the initial expense, we feel tempted to describe a cheap form of arrangement which we can vouch for as being a practical one, as all the photos in this book have been taken with it either by my son or by myself.* There is *nothing* original or even novel to especially recommend in it, save that of utility and cheapness; and that the camera used is only *an ordinary* quarter-plate one (or half-plate if desired); and that it can be made by any one who has tools at his command or can employ a carpenter of ordinary intelligence. (Figs. 24a and 24b.)

If the reader will refer to the chapter on low-power photo-micrography (p. 24), he will see there described how the camera was recommended to be fitted to a certain form of wooden block, all dimensions being given. It will be further seen on looking towards the end of the description that a second simple form of railed board was advised to be made wherewith to take the photos of the culture tubes (pp. 26, 27). Another of these should now be constructed, but of still more solid character—the board itself being $1\frac{1}{2}$ inches thick, 4 feet 6 inches long, and 9 inches wide, and attached permanently to the table—whether with legs or slung—by strong screws passing through rubber washers. A central line should be firmly drawn along the table corresponding with the axis of the camera when *in situ*.

The focussing-rod arrangement is novel to a small degree—as seen in the blocks Figs. 24a and b, and Fig. 24c. It is supported by a square piece of wood, better seen when looking at the plan diagram. The pulley end is capable of movement laterally, turning upon the pin, also shown. When arranging the silk cord passing from the fine adjustment to the pulley on the focussing-rod, the piece of wood is brought *near* to the microscope, thus enabling the operation to be done quite easily. After it has been passed over both (the pulley and the fine-adjustment screw) the wood is pushed *away* from the microscope and fixed there by a thumbscrew, just visible in the plan diagram at the foot of the exposure shutter, passing through a slot into the table. This method is convenient, as any stretching of the cord can be taken up as much as necessary, and it enables the operator to slip on the cord without disturbing the focus to any sensible amount.

It is not difficult to understand on looking at Figs. 24a, b, or c, that the camera slides to and fro between the rails fixed in the base-board of the apparatus. It not only slides to and fro, but takes *completely off* when the wooden screws are unloosed. By this simple means the camera in its entirety can instantly be transferred to either

* The whole of the photographs of the "Atlas of Bacteriology" were also taken on this stand. Some are reproduced in Plate V. of this work through the kindness of the Publishers.

PHOTO-MICROGRAPHY

Fig. 24a

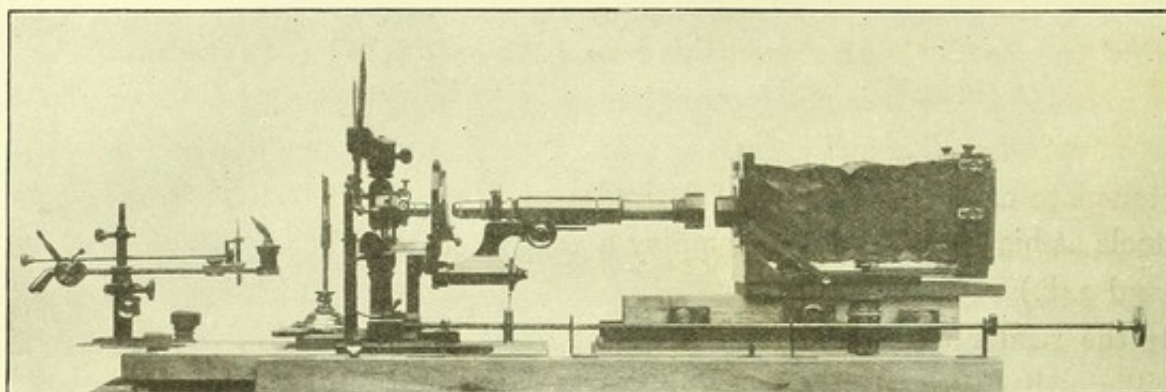

Elevation

Fig. 24b

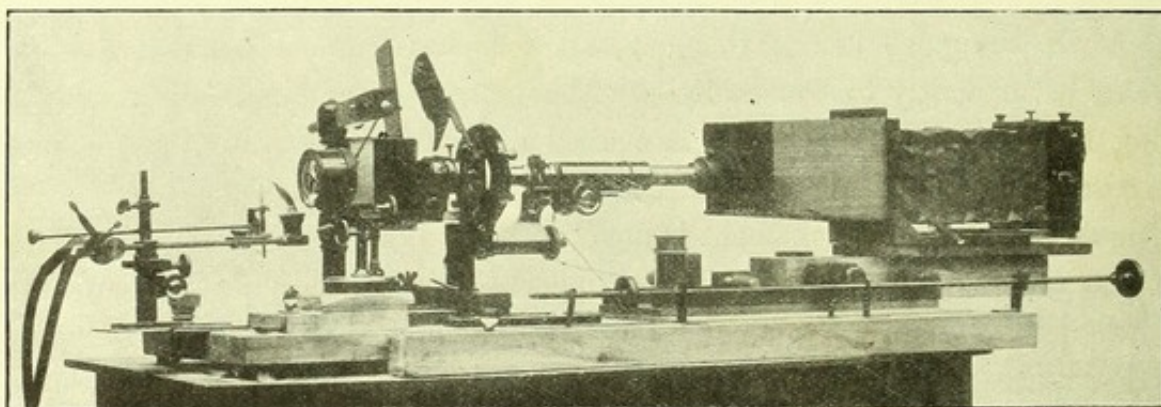

Elevation

Fig. 24c

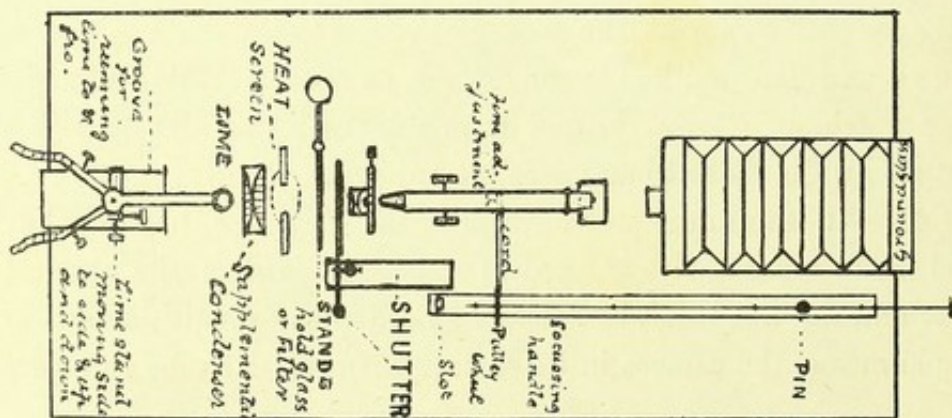

Plan

apparatus we have previously mentioned—one for low-power work and the other for “tube” work—without any loss of time, as the same block fits both, the rails being made the same width apart. Besides this, removal of the entire camera allows the photographer the opportunity to examine his specimen sufficiently for all purposes provided he has previously found the “best place.” When we speak later upon “taking the photograph” we shall refer to this again. Doing away with the rotating-board is an economy, and its loss we have but rarely felt.

With respect to the ground glass screen-holder of the camera, we have had it made in such a fashion that the glass itself can be slipped out by the release of two springs, and others, whether plain, smoked, or more finely ground, easily substituted. Turning these springs on one side, the glass falls out; turning them back again, another can be fixed. With respect to the kinds of ground glass employed, we use three varieties:—The ordinary coarse-grained one, another of finer texture, and a third made specially for us by Ross, Ltd., which is so fine as to hardly be worthy of the name of ground glass at all. When commencing to take a photograph either the first or second is used, and after illuminating the field equally, in a manner to which we shall presently refer, one proceeds to focus; if that can be done on the coarse or medium glass we are always more satisfied; but if with extremely difficult objects the ability to do so is not certain, we change to the finest type or even use a piece of plain glass. The objection to using plain glass or the finest of the ground glasses, in the first instance, is that the general appearance of the field is entirely lost: you see nothing with the naked eye but light streaming from the eyepiece, and, therefore, any inequality of the illumination is sure to escape notice. But for the more accurate focussing that is required with the secondary markings of diatoms or the flagella of bacteria we resort to it accompanied by the use of a focussing-glass, which is shown in the diagram near the foot of the camera. Much difference of opinion exists as to what kind of magnifying glasses it is better to use.

Dr. Bousfield, an eminent photo-micrographer, advocates the use of a lens with as low a power as possible; others prefer a spectacle lens mounted in a frame much like an ordinary pair of spectacles, having about an inch focus; whereas not a few prefer the ordinary photographic hand-magnifier, which has already been referred to, providing it is achromatic. Personally, we have a predilection for this type, and use one made by Dallmeyer, which he terms his “Low-power focussing hand-magnifier.” Before using a hand-magnifier, however, it should be carefully focussed on the *same ground glass upon which it is to be employed*. This is not quite so easy a matter as one would think, for it requires a little practice to know when the glass grinding

marks are really strictly in focus. It is a good plan to draw a pencil mark on the ground glass, and then applying the magnifier to its plain surface, to hold both to the light, and to keep altering the focussing-screw of the magnifier until the grains of the

Fig. 25

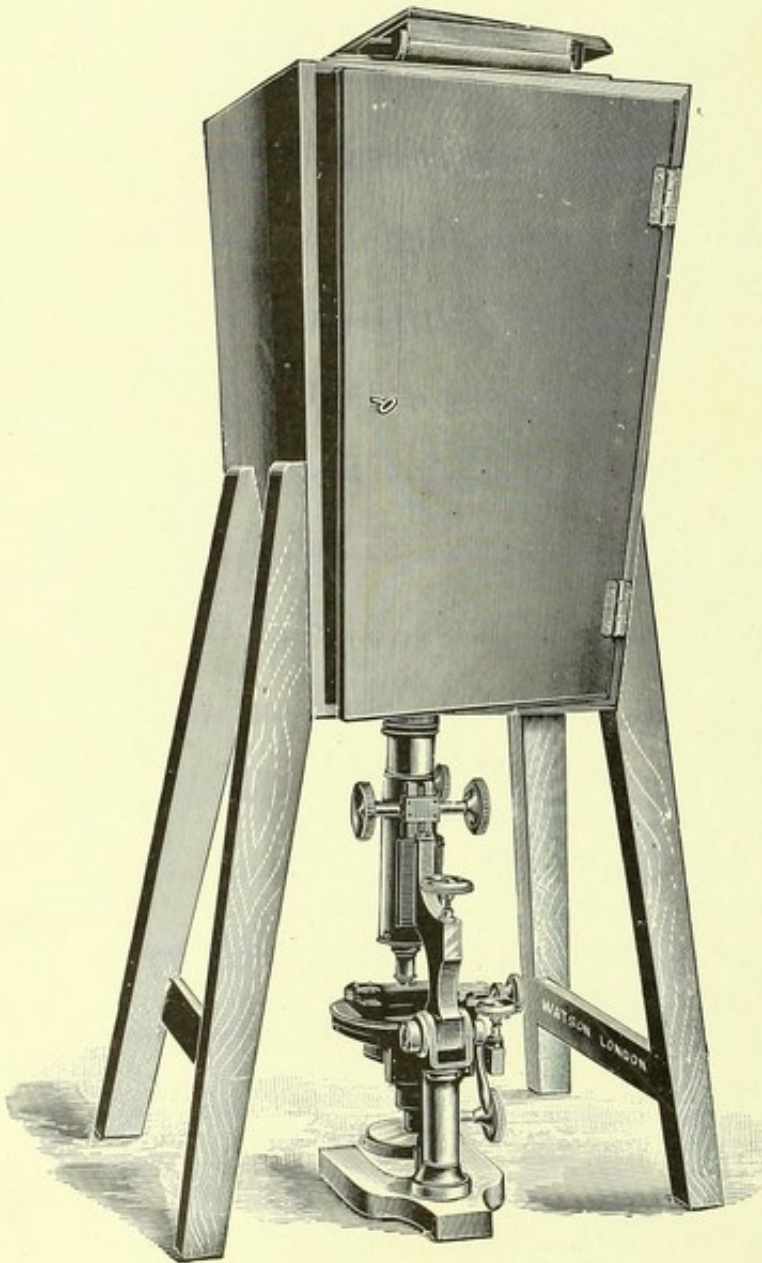

lead are seen on the glass. No pains should be spared in getting this focus accurately, for, it is needless to point out, if carelessly done, it will affect the final use of the magnifier. This is the only trouble of using three kinds of ground glass, lest one should vary in thickness and so upset the focussing arrangement of the magnifier. Of course, the only way out of such a trouble is to be careful to procure three pieces of the same thickness.

With our arrangement, when we desire to increase the camera length we employ the "additional front" to which reference has already been made. In Fig. 24a the apparatus is used with *no* auxiliary lens, no water bath, and no "front," but in b these are all shown.

Here ends the description of the usual form of apparatus sold for the purposes of photo-micrography; but to make our description as comprehensive as possible, we must state that at times the photographing of specimens which *must* be kept horizontal demands the employment of what is termed a "vertical arrangement."

A few workers in the subject speak highly of this form; indeed, the celebrated Dr. Van Heurck prefers it entirely for all classes of work. This is not, however, we think, the opinion generally met with. The form of stand, until quite recently, which has met with the most approval is that designed by Dr. Van Heurck himself, and sold by

Fig. 26

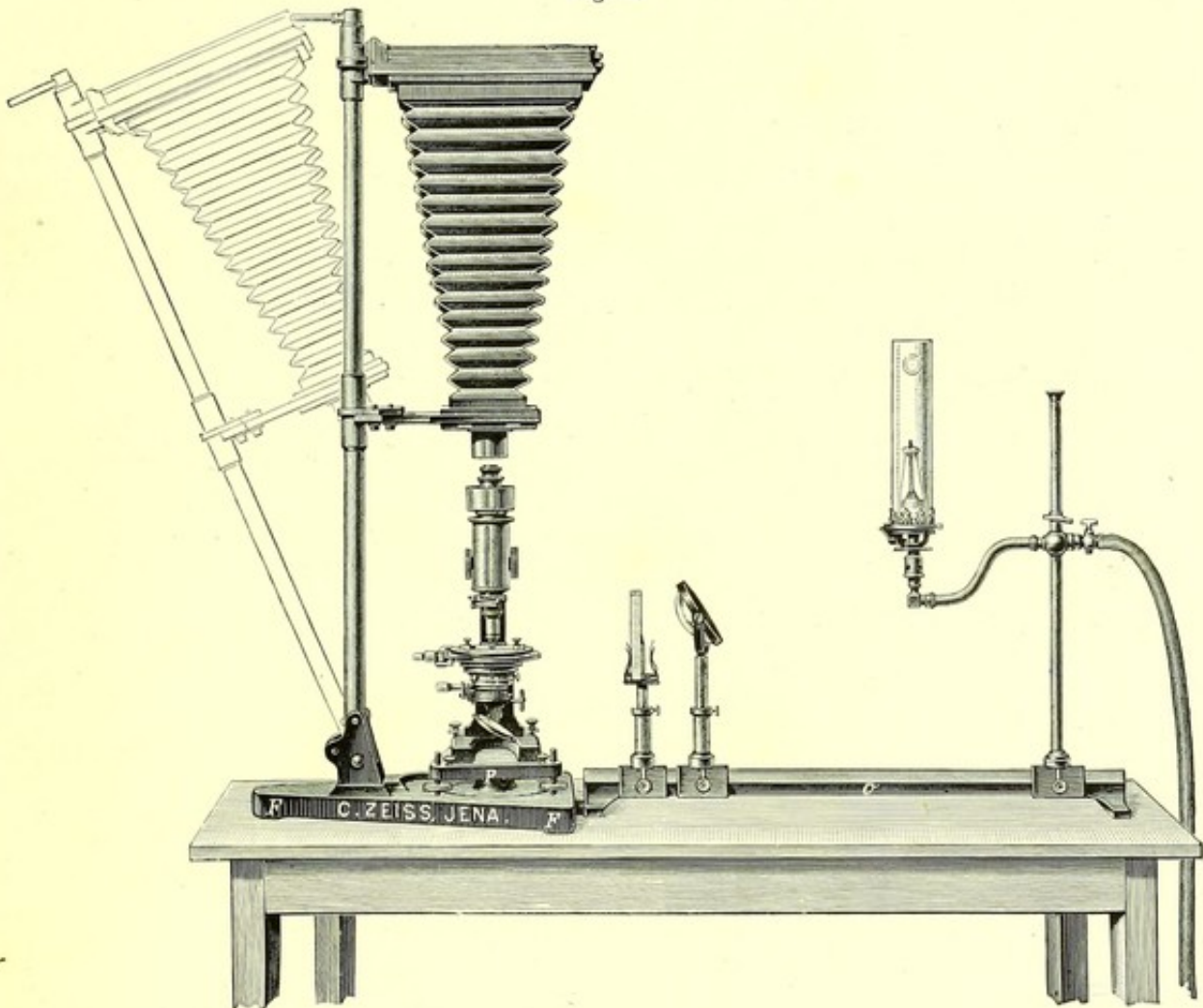
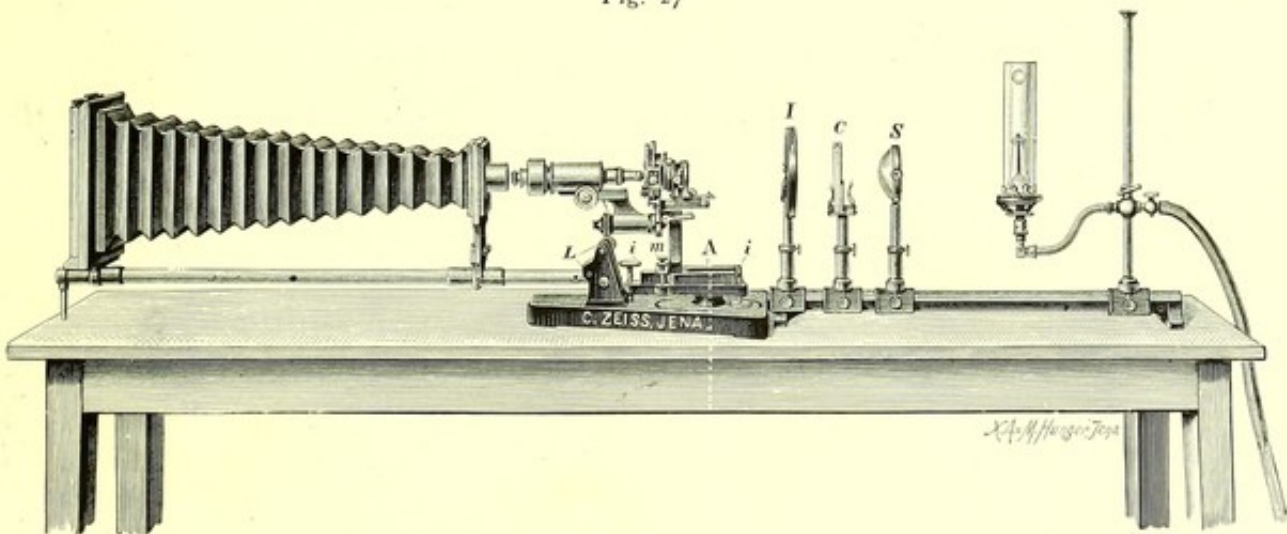

Fig. 27



H

Messrs. Watson and Son, being shown in Fig. 25. The block explains itself. It will be seen that the microscope is used *with* a mirror, and it will be further understood after a little consideration that an objection which holds good to all makes of upright apparatus is especially noticeable in this arrangement—viz., that there is but little possibility for the use of *extended camera lengths*. To this we shall draw attention in a future article, when describing how to use the apparatus.

Quite recently the firm of Zeiss have brought forward a somewhat new design, which is capable of being used vertically, at an angle of 45° to the vertical, and horizontally, which for many purposes promises to be of great service. We have critically examined it, and can vouch for the excellency of the details and general arrangement. In calling this stand new, we must admit that some other foreign firms, as well as some English ones, have sold much the same *design* before; but we think perhaps not in such a solid and useful form, neither have the details been at all similar. It should be seen to be appreciated. It is shown in Figs. 26 and 27, where it is exhibited in the vertical and other positions. We may mention that the camera is very large and of foreign dimensions, which would be troublesome to English workers because of either having to employ foreign-sized plates or a plate-holder, neither of which are to be recommended. No doubt the firm could alter this on demand.

CHAPTER IV

THE MICROSCOPE, LENSES, AND EYE-PIECES USED IN MEDIUM
AND HIGH-POWER WORK

IN this chapter are explained: Section I.—(i) The microscope stand itself; (ii) the fine adjustment; (iii) the movable nose-piece and Davis diaphragm; (iv) the mechanical stage; (v) the movable substage.

Section II.—(i) The objectives; (ii) numerical aperture, what is meant by the term, and how it is obtained by the Apertometer and by other means; (iii) eye-pieces.

SECTION I.—THE MICROSCOPE AND ITS FITTINGS

(i) The instrument must be one of the best manufacture, for when dealing with high-powers and critical work nothing short of *the best* will enable the operator to turn out good work. The leading points to bear in mind when choosing a microscope for this work may be summarised under the following six heads:

1. **The Stand Itself.**—Must be very heavy, built without shake and *well* balanced when placed horizontally.

Its base should be broad and its adjustments within easy reach. The general design is much the same as sold by different makers, but the details vary considerably, and as these conform to make the superiority or otherwise of the model, so we give blocks of most of the leading firms for comparison. Space will not allow a description of each, and as to the best firm it is purely a matter of taste. All are excellent and the best firms all turn out good work if a proper price be paid. But if the tyro expects to get all that is refined and elegant for the delicate work of photomicrography for a mere song, or who, neglecting the recognised channels we are pointing out for obtaining trustworthy work, goes haphazard to the nearest "Stores," or to some second-hand tool-shop, he must not expect to be otherwise than disappointed.

We here append woodcuts of the microscopes sold by many leading manufacturers arranged in alphabetical order, commencing first with the "Nelson" model as made by Baker of Holborn (Fig. 28). We do not propose to occupy time and space by describing each variety, for, seeing this book is only for the assistance of the photomicrographer and *not* a treatise on the microscope proper, it would be foreign to the object of the work.

Fig. 28

NELSON MODEL. SOLD BY BAKER, OF HIGH HOLBORN

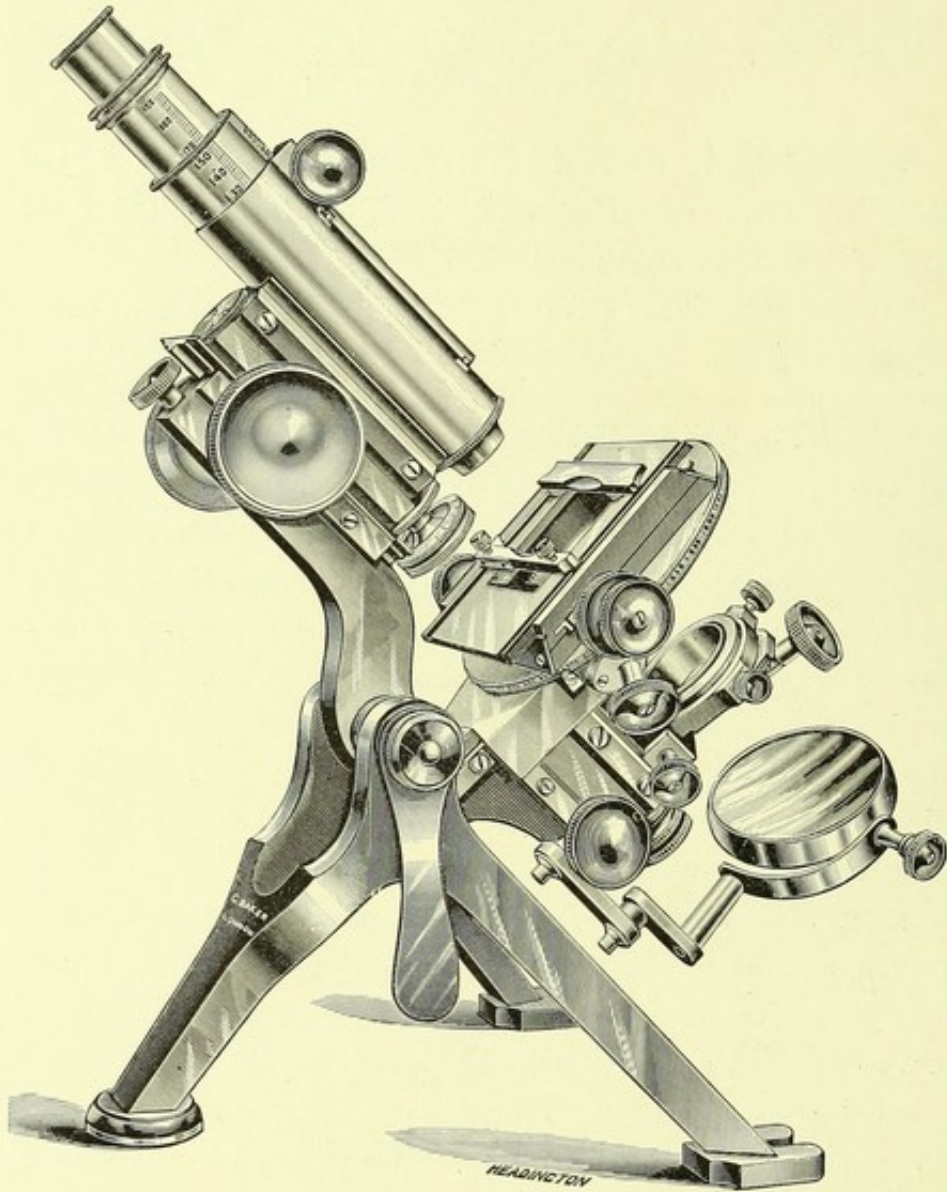

DIMENSIONS.

| | INCHES |
|---|------------------|
| Height when in vertical position and body racked down | 12 $\frac{1}{2}$ |
| Height of stage | 6 |
| Height of optic axis when in horizontal position | 10 |
| Spread of tripod foot | 9 x 11 |
| Diameter of mirrors | 3 |
| Internal diameter of draw tube | 1 $\frac{1}{16}$ |

Fig. 28a

SOLD BY R. & J. BECK, OF CORNHILL

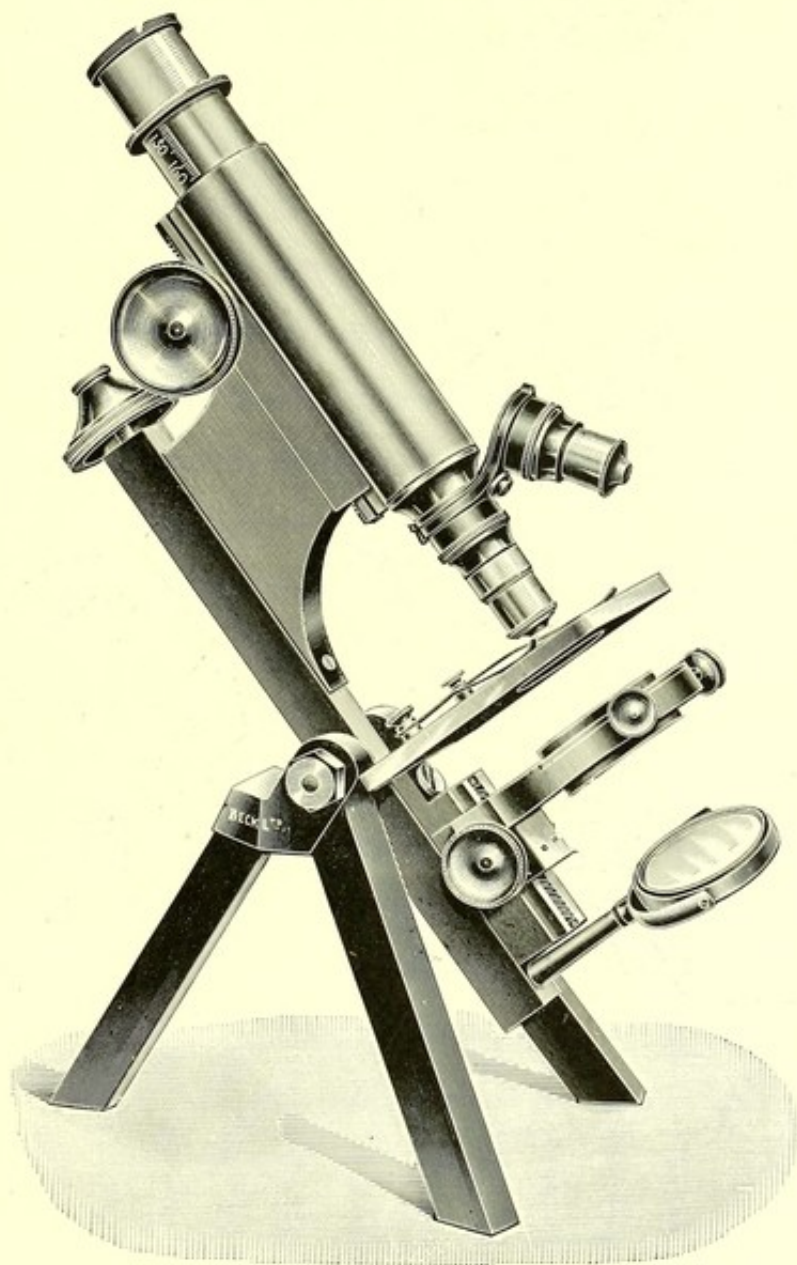

DIMENSIONS.

| | INCHES |
|---|-----------------|
| Height when in vertical position and body racked down | 9 |
| Height of stage | $4\frac{1}{2}$ |
| Height of optical axis when in horizontal position | $6\frac{4}{15}$ |
| Spread of tripod foot | 7 |
| Diameter of mirrors | $1\frac{6}{10}$ |
| Internal diameter of draw tube | $1\frac{1}{8}$ |

Fig. 29

SOLD BY MESSRS. POWELL & LEALAND, OF 170 EUSTON ROAD, N.W.

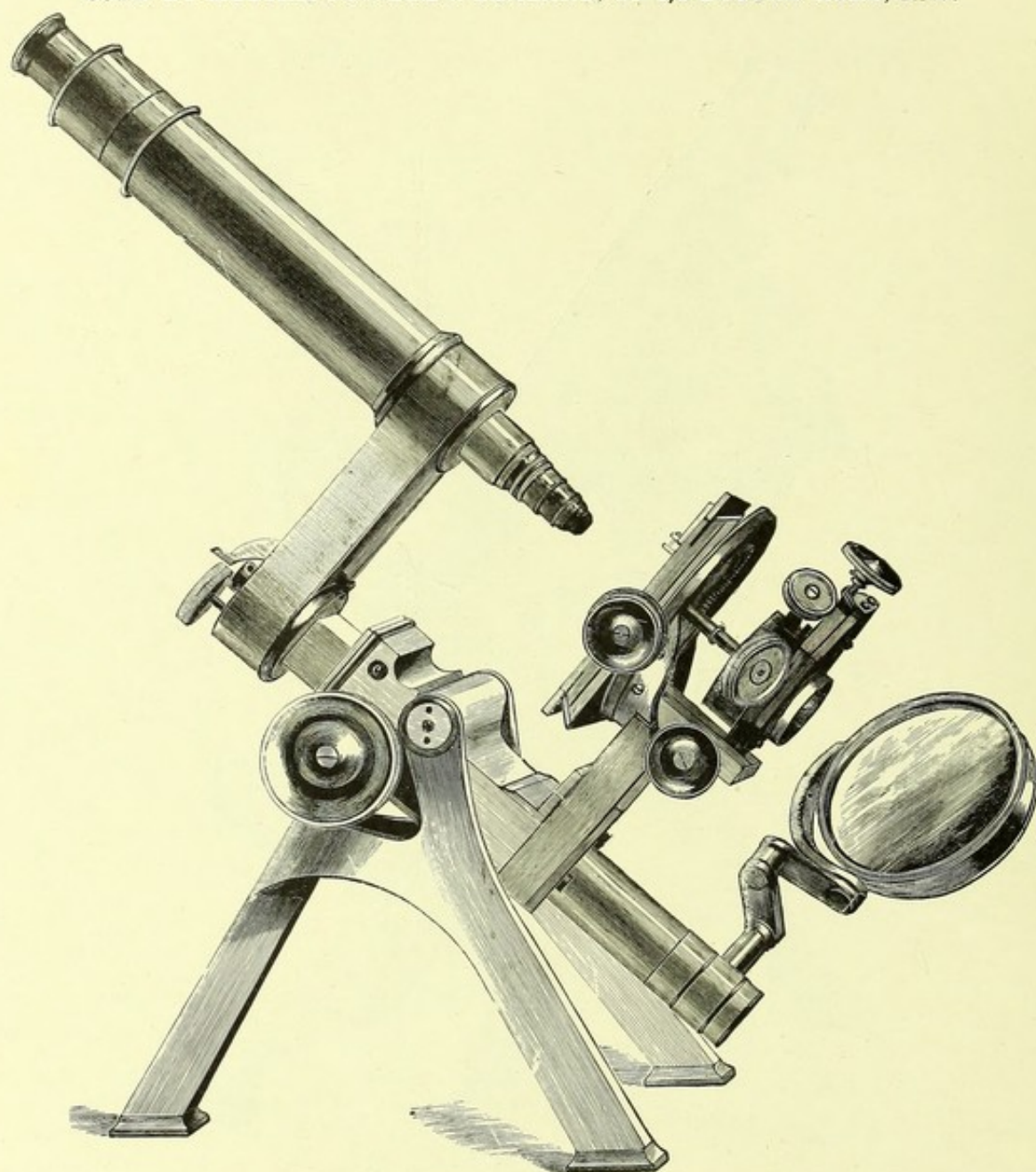

DIMENSIONS.

| | INCHES |
|---|--------|
| Height when in vertical position and body racked down | 15½ |
| Height of stage | 5¼ |
| Height of optical axis when in horizontal position | 10 |
| Spread of tripod foot | 7¼ |
| Diameter of mirrors | 3 |
| Internal diameter of draw tube | 1⅞ |

Fig. 30

SOLD BY ROSS & CO., OF NEW BOND STREET, W.

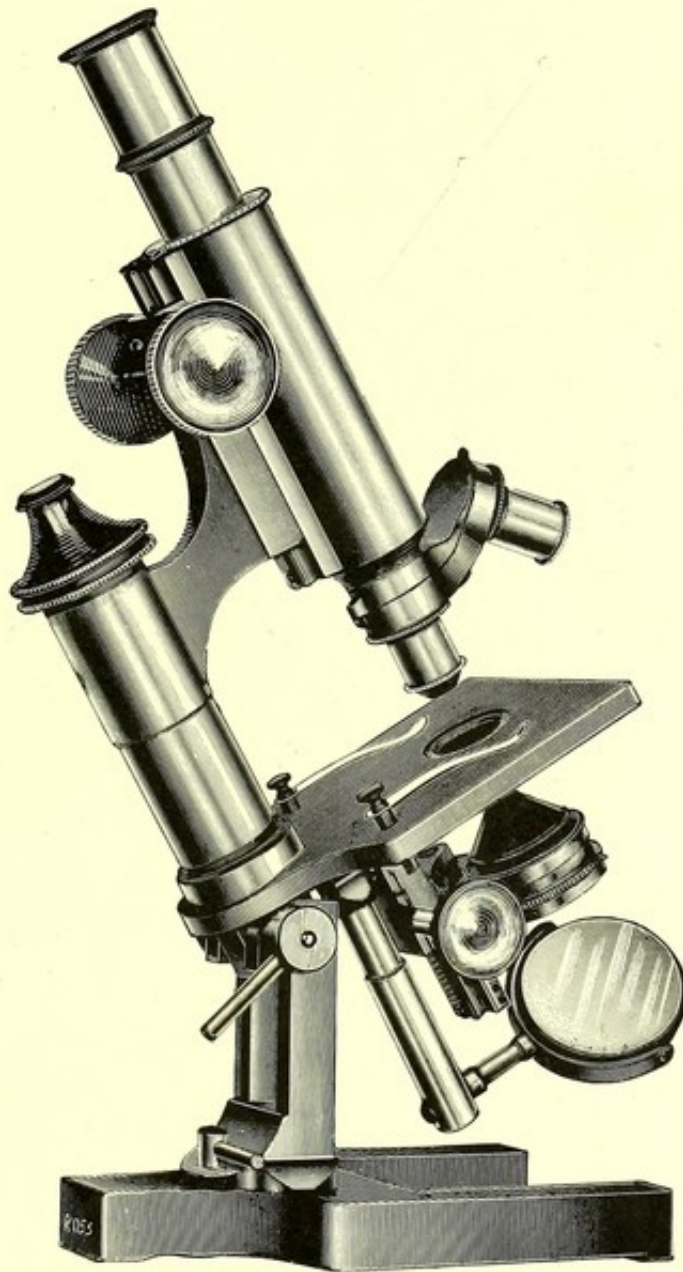

DIMENSIONS.

| | INCHES |
|--|---|
| Height in vertical position and body racked down | 12 |
| Height of stage | 4 ¹ / ₂ |
| Height of optical axis when horizontal | 6 ¹ / ₂ |
| Spread of foot | 4 ¹ / ₂ × 6 ¹ / ₂ × ¹ / ₂ |
| Diameter of mirror | 1 ¹ / ₂ |
| Internal diameter of draw tube | 23 mm. |

Fig. 31

FOUR-LEGGED MICROSCOPE. SOLD BY SWIFT & SON, OF 81 TOTTENHAM COURT ROAD, W.

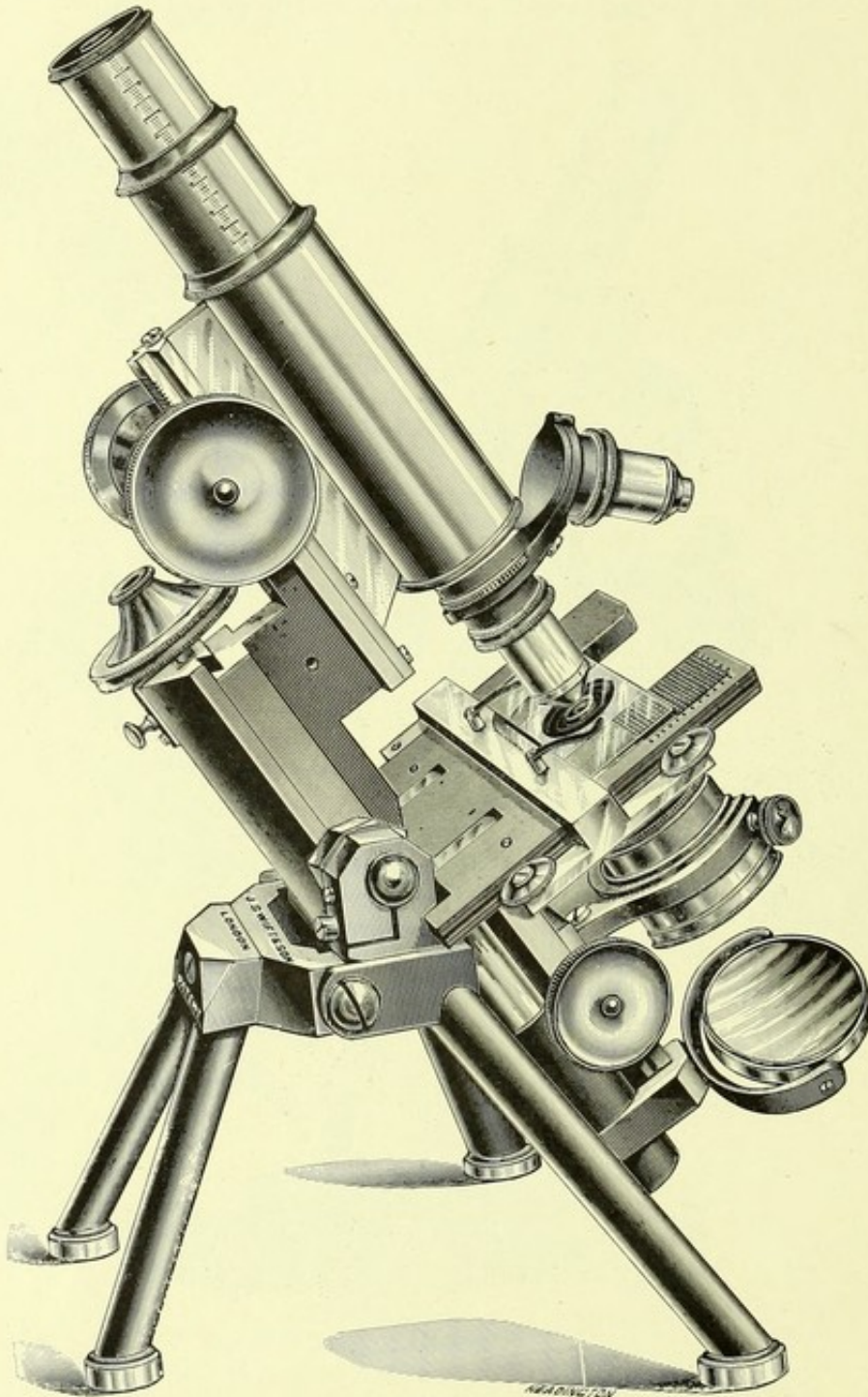

DIMENSIONS.

| | INCHES |
|---|------------------|
| Height when in vertical position and body racked down | 10 |
| Height of stage | 4 $\frac{1}{2}$ |
| Height of optical axis when horizontal | 7 $\frac{1}{2}$ |
| Spread between the two front feet | 8 |
| Spread between the two back feet | 7 |
| Diameter of mirrors | 1 $\frac{7}{16}$ |
| Internal diameter of draw tube | 1 $\frac{1}{16}$ |

Fig. 32

VAN HEURCK MODEL. SOLD BY WATSON & SONS, OF 313 HIGH HOLBORN, LONDON, W.C.

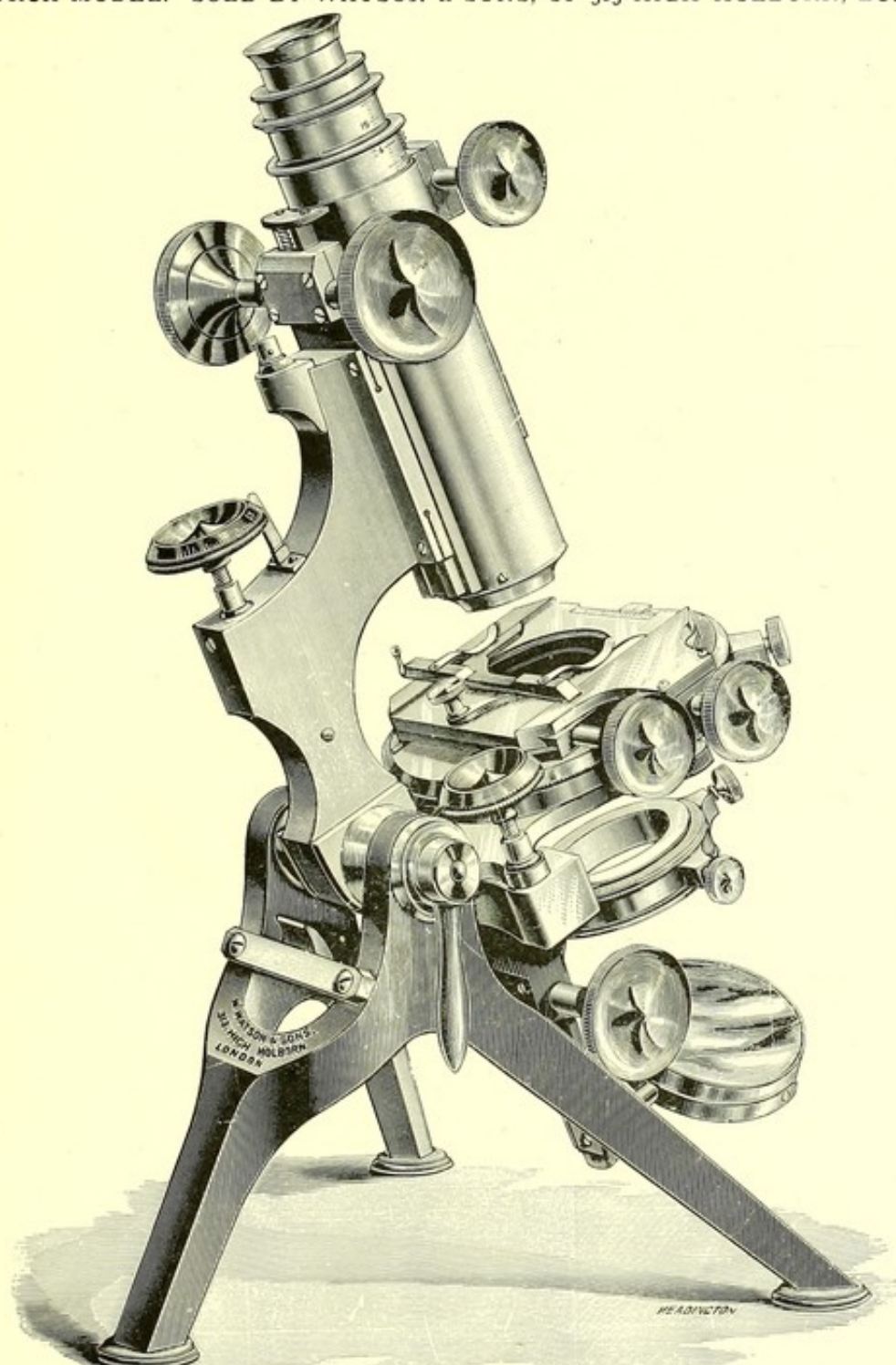

DIMENSIONS.

| | INCHES |
|---|--------------------------------|
| Height when in vertical position and body racked down | 13 ¹ / ₂ |
| Height of stage | 6 |
| Height of optical axis when horizontal | 8 ¹ / ₂ |
| Spread of tripod foot | 8 ¹ / ₂ |
| Diameter of mirrors | 2 ¹ / ₂ |
| Internal diameter of draw tube | 1 ³ / ₁₆ |

Fig. 33

EDINBURGH MODEL. SOLD BY WATSON & SONS, OF 313 HIGH HOLBORN, LONDON, W.C.

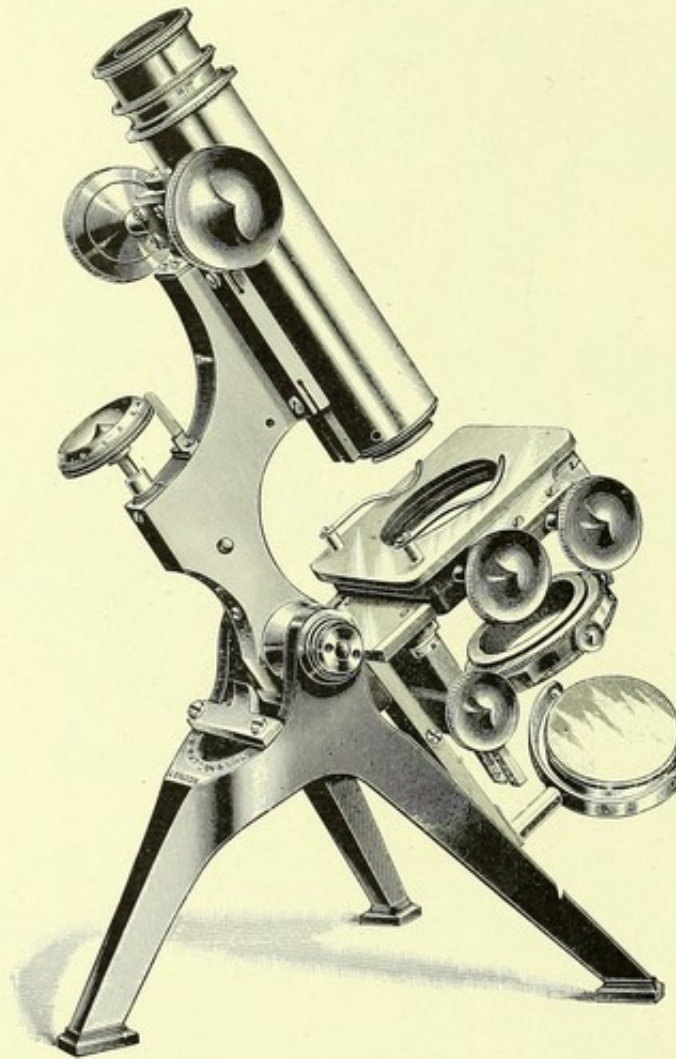

DIMENSIONS.

| | INCHES |
|---|----------------|
| Height when in vertical position and body racked down | 12 |
| Height of stage | $4\frac{1}{2}$ |
| Height of optical axis when horizontal | $7\frac{1}{2}$ |
| Diameter of mirrors | 2 |
| Internal diameter of draw tube | $\frac{1}{8}$ |

Fig. 34

FRAM MODEL. SOLD BY WATSON & SONS, OF 313 HIGH HOLBORN, LONDON, W.C.

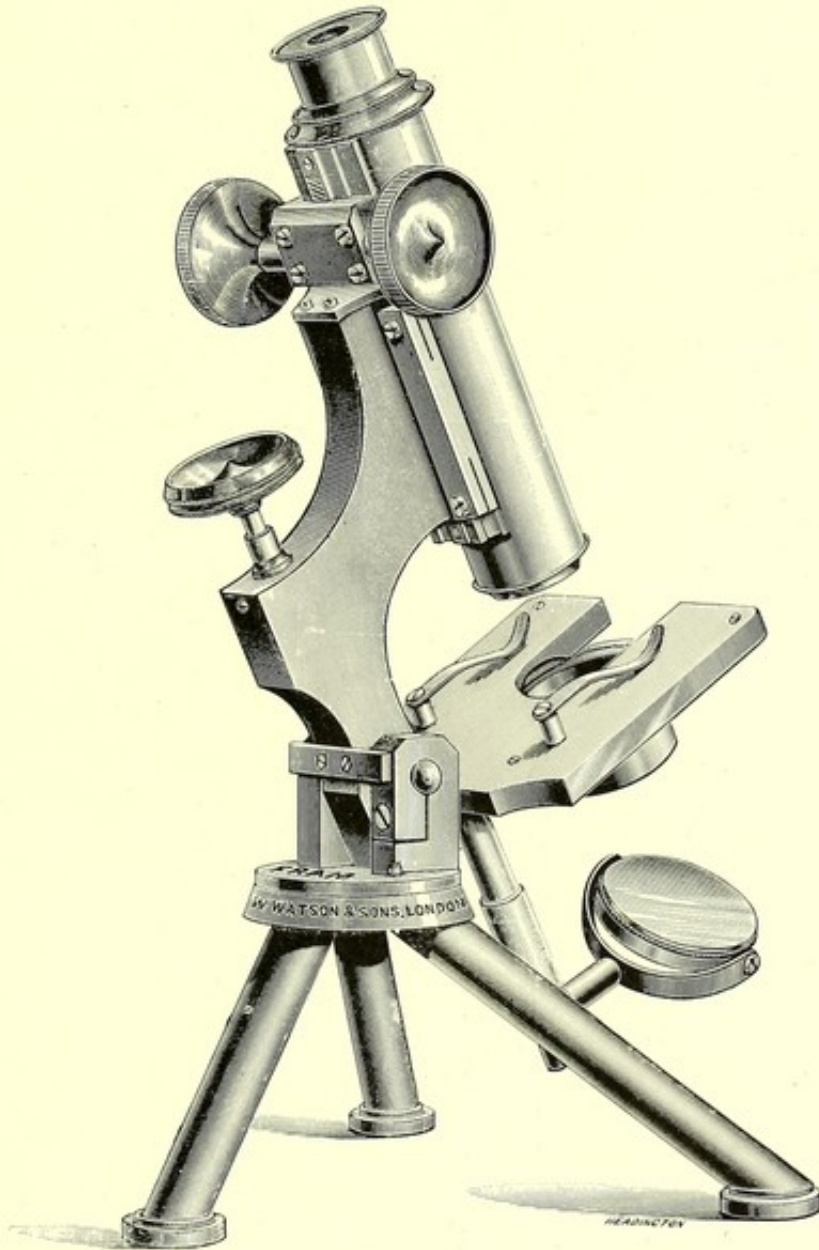

DIMENSIONS.

| | INCHES |
|---|------------------|
| Height when in vertical position and body racked down | 10 $\frac{3}{4}$ |
| Height of stage | 3 $\frac{1}{4}$ |
| Height of optic axis when in horizontal position | 7 $\frac{3}{8}$ |
| Spread of tripod foot | 7 |
| Diameter of mirror | 1 $\frac{1}{4}$ |
| Internal diameter of draw tube | .92 in. |

PHOTO-MICROGRAPHY

Fig. 35

STAND 1a AS USED BY THE AUTHOR.

SOLD BY ZEISS, OF 29 MARGARET STREET, REGENT STREET, LONDON, W.

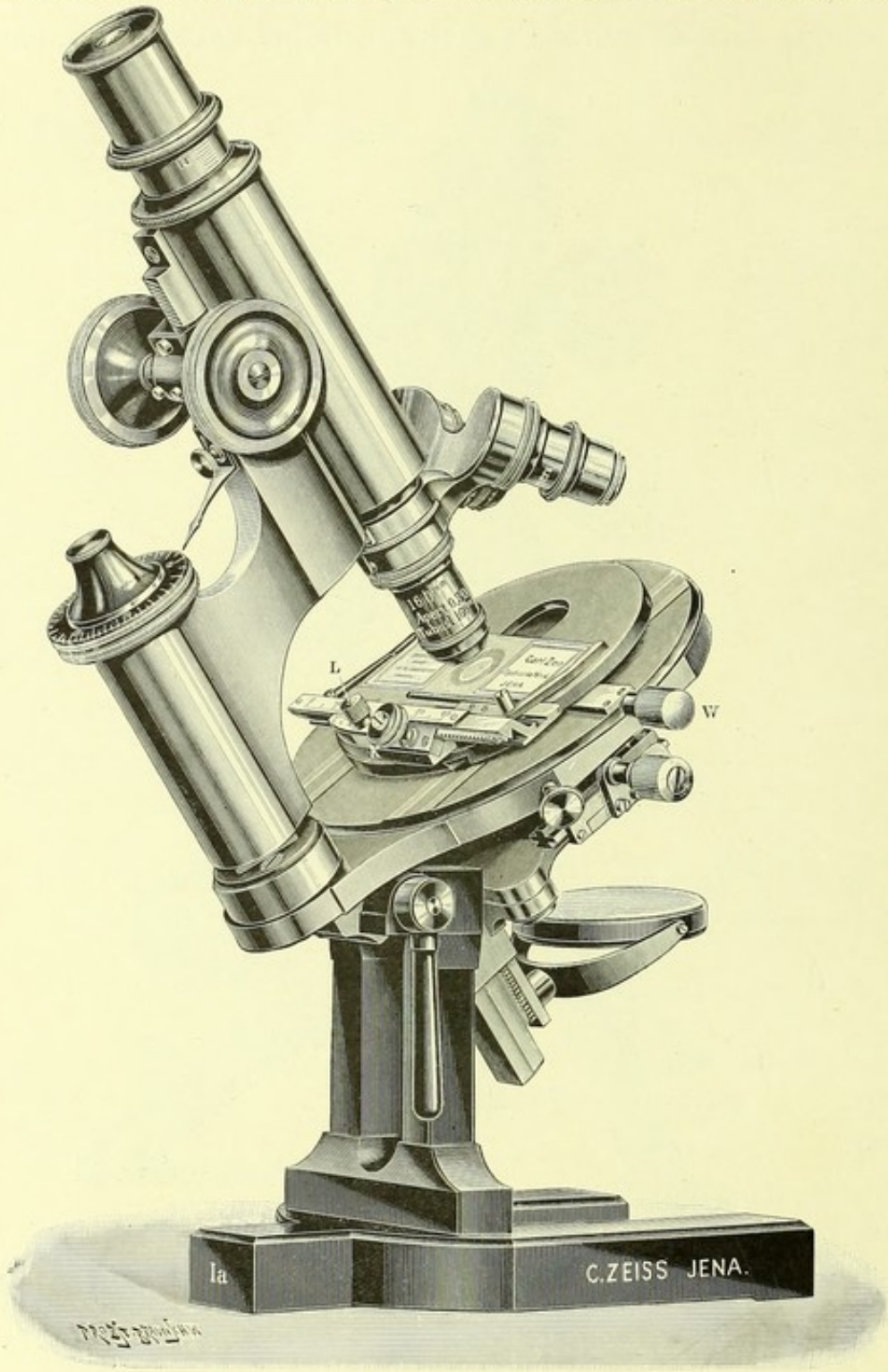

DIMENSIONS.

| | INCHES |
|---|--------------------------------|
| Height when in vertical position and body racked down | 11 |
| Height of stage | 5 |
| Height of optical axis when horizontal | 6 ¹ / ₂ |
| Spread of foot | 4 ¹ / ₂ |
| Diameter of mirrors | 1 ¹ / ₁₆ |
| Internal diameter of draw tube | 1 ¹ / ₁₆ |

Fig. 36

SPECIAL PHOTOGRAPHIC STAND PREFERRED BY SOME TO THE 1a STAND

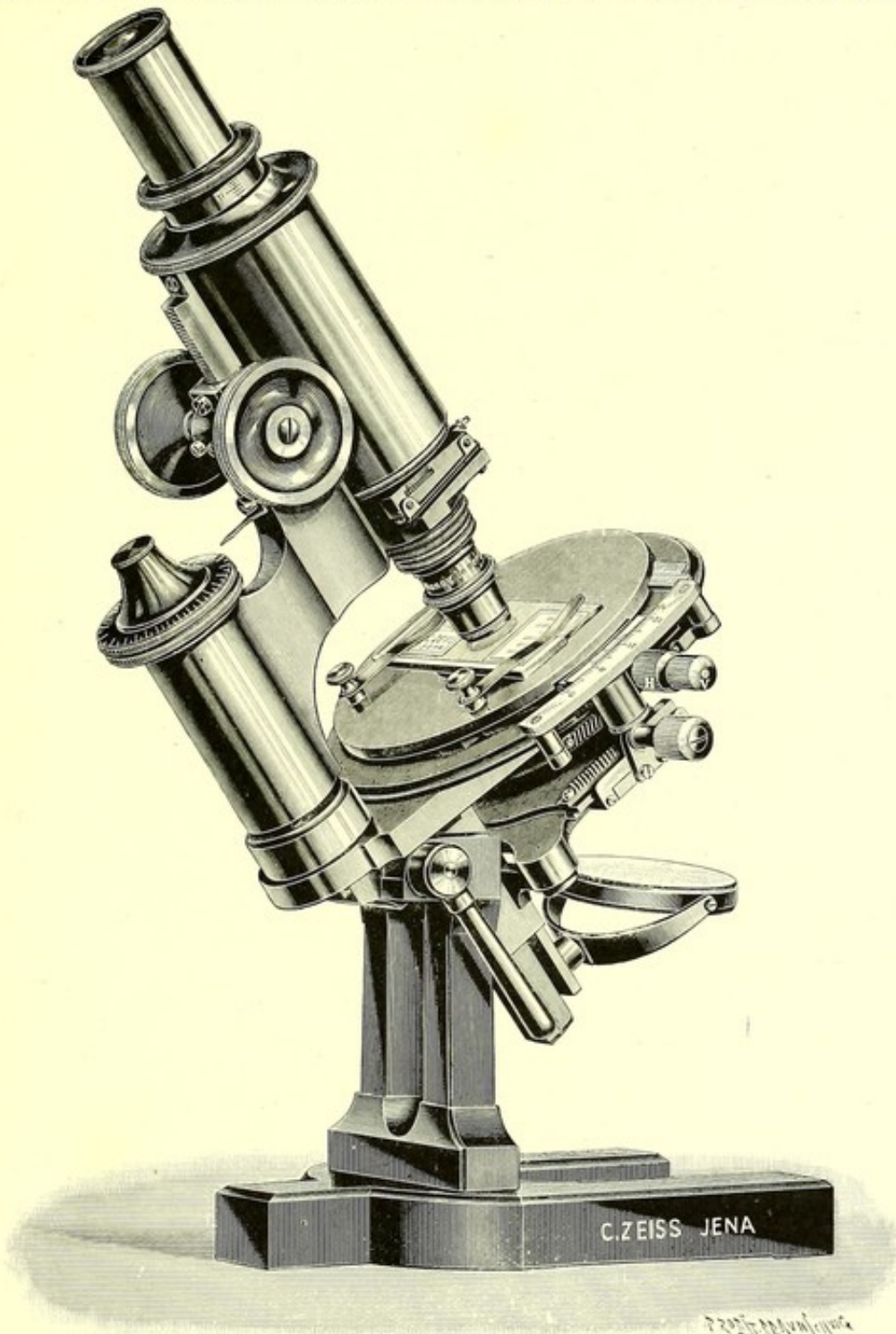

DIMENSIONS.

| | INCHES |
|---|-----------------|
| Height when in vertical position and body racked down | 7 $\frac{1}{2}$ |
| Height of stage | 5 |
| Height of optical axis when horizontal | 6 $\frac{1}{2}$ |
| Spread of foot | 4 $\frac{1}{2}$ |
| Diameter of mirror | 2 |
| Internal diameter of draw tube | $\frac{9}{16}$ |
| Internal diameter of body with tube withdrawn | 1 $\frac{1}{8}$ |

(ii) **The Fine Adjustment** should be of exceptional workmanship. There are some microscopes sold where it is not worthy of the name.

Several forms exist and opinion very much varies which is the best. Dr. Dallinger, who is such a veteran microscopist, expresses his belief (see latest edition of Carpenter on the Microscope), that the *ideal* form is that adopted by the eminent firm of Powell and Lealand, Fig. 29, and that, although designed over forty years ago, has never been beaten and rarely if ever equalled. On the other hand many, whilst admitting the excellence of all work coming from the workshops of so celebrated a firm, prefer the model as made by Messrs. Watson & Sons, shown in Figs. 32, 33, 34 and 37; whilst Mr. Nelson—and to mention his name immediately engages the attention of any one professing to know or even to have heard anything about the microscope—in the model called after his name, and sold by Baker of Holborn, selected that particular design known as Campbell's Differential Screw. It is illustrated in Fig. 38, but for a detailed description we must refer the reader to works on the microscope.

Others strike out a different path and prefer the complete Continental pattern, a type of which is seen in the fine adjustment met with in the Zeiss 1A Stand, Figs. 35 and 36.

Selection of the microscope then is a personal matter, and it appears to us not to matter much, provided whatever is chosen be really of fine manufacture. In our case we are very content with the Continental design as made by Zeiss in his 1A stand, which we are constantly using, and were it not that the lubricant used by the firm requires modification, no reasonable microscopist could want anything better.* The drying up, or otherwise spoiling, of the lubricant, however, is a most annoying matter; for example, just as an object is being finally focussed before taking a photograph, to find the fine adjustment *won't work!* On these grounds we venture, for the benefit of our readers who employ this firm's otherwise excellent stand, to append a footnote showing how to clean and rectify the adjustment when it becomes clogged.†

* The author does not say this without justification. He used this stand to take all the photographs in this book and also those in "An Atlas of Bacteriology," of which with Dr. Slater he is joint author.

† On the *stem* of the microscope, underneath the milled head of the fine adjustment, *after lowering* by its means the microscope towards the specimen, *will be seen* on each side a small hole. A piece of soft steel exactly the size to fit these holes must be procured about 2 inches in length. Placing the pin in the hole, it is turned in the opposite direction to the hands of a watch; round and round, until the top comes off. Looking inside, a key screw will then be seen, which has to be undone by inserting a key properly made to fit. A few turns in the same direction as the first screw and it is released and with it the spring. The body will then come off, and can be cleaned by passing through it a handkerchief several times. No lubricant I know of equals fine chronometer oil put on *very* thinly—tallow and wax, so often used, are abominable, and turn green after but a short interval of use. Both the keys can be procured to fit at a trifling cost from Mr. Mason, optician, Park Road, Clapham.

Fig. 37

THE FINE ADJUSTMENT SOLD BY WATSON & SONS

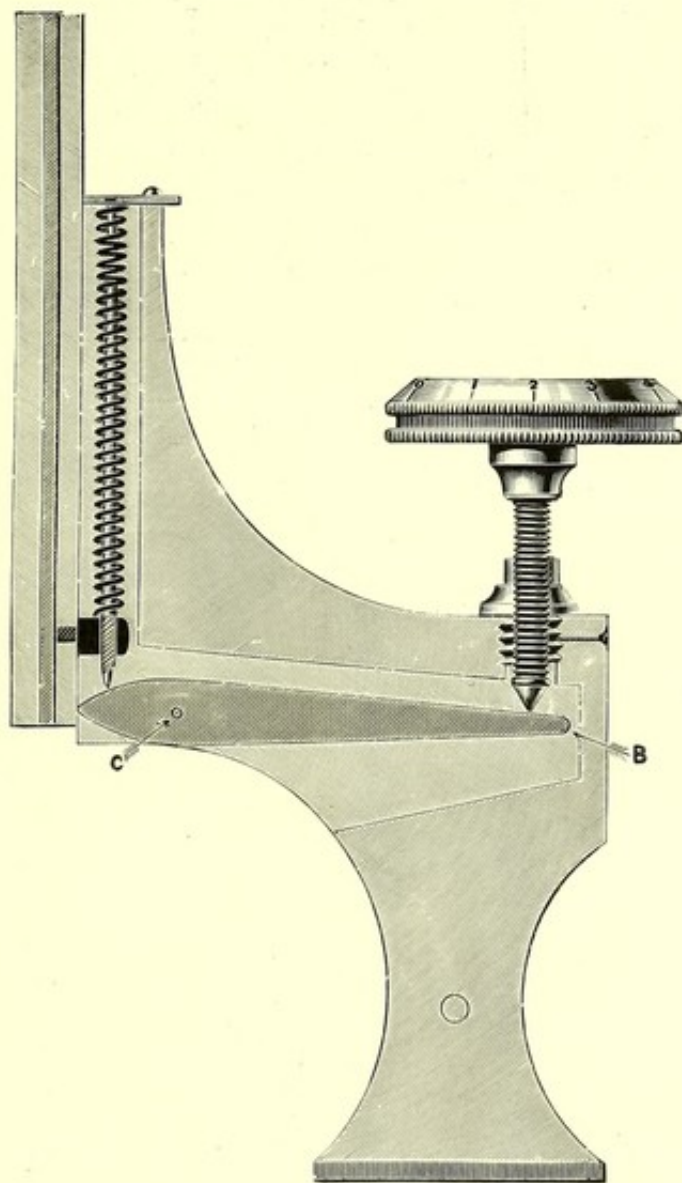
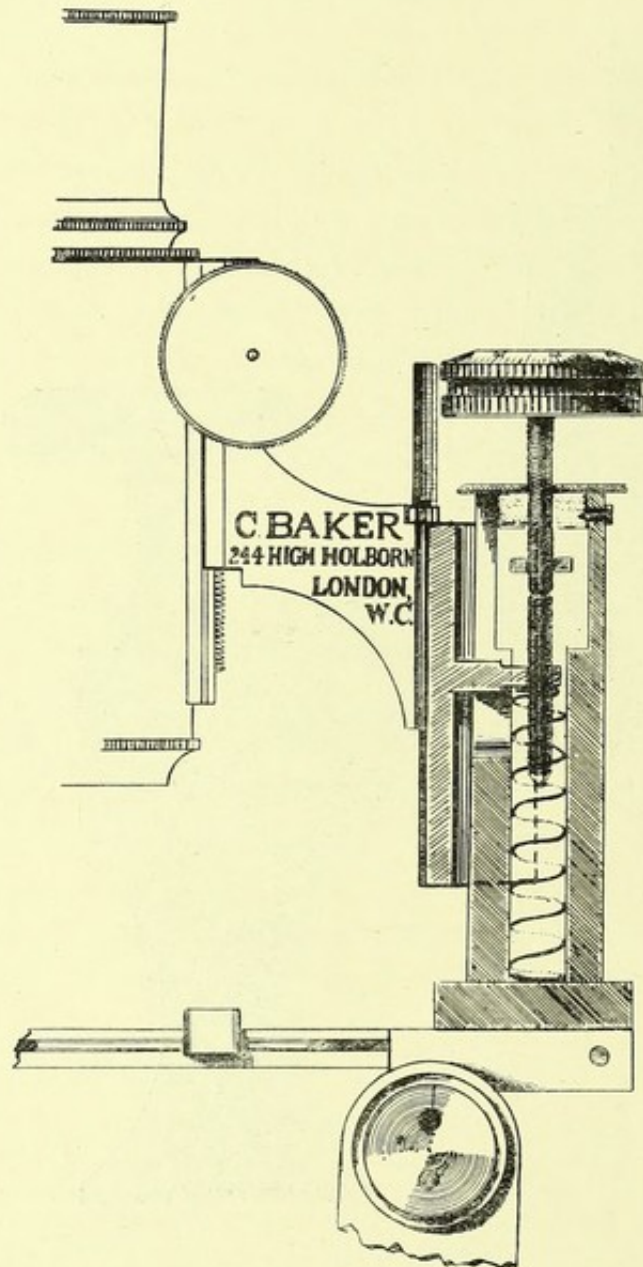

Fig. 38

THE FINE ADJUSTMENT, CAMPBELL DIFFERENTIAL SCREW, SOLD BY BAKER



(iii) **The Movable Nose-piece for Rapidly Changing the Objectives.**—

The ordinary method is that of affixing to the end of the tube what is commonly called a *revolving* nose-piece. These are made to hold two, three or four objectives, and if they could be made so true that when an object is found with a half inch it would be equally in the centre of the field when the eighth is brought into position it

Fig. 39

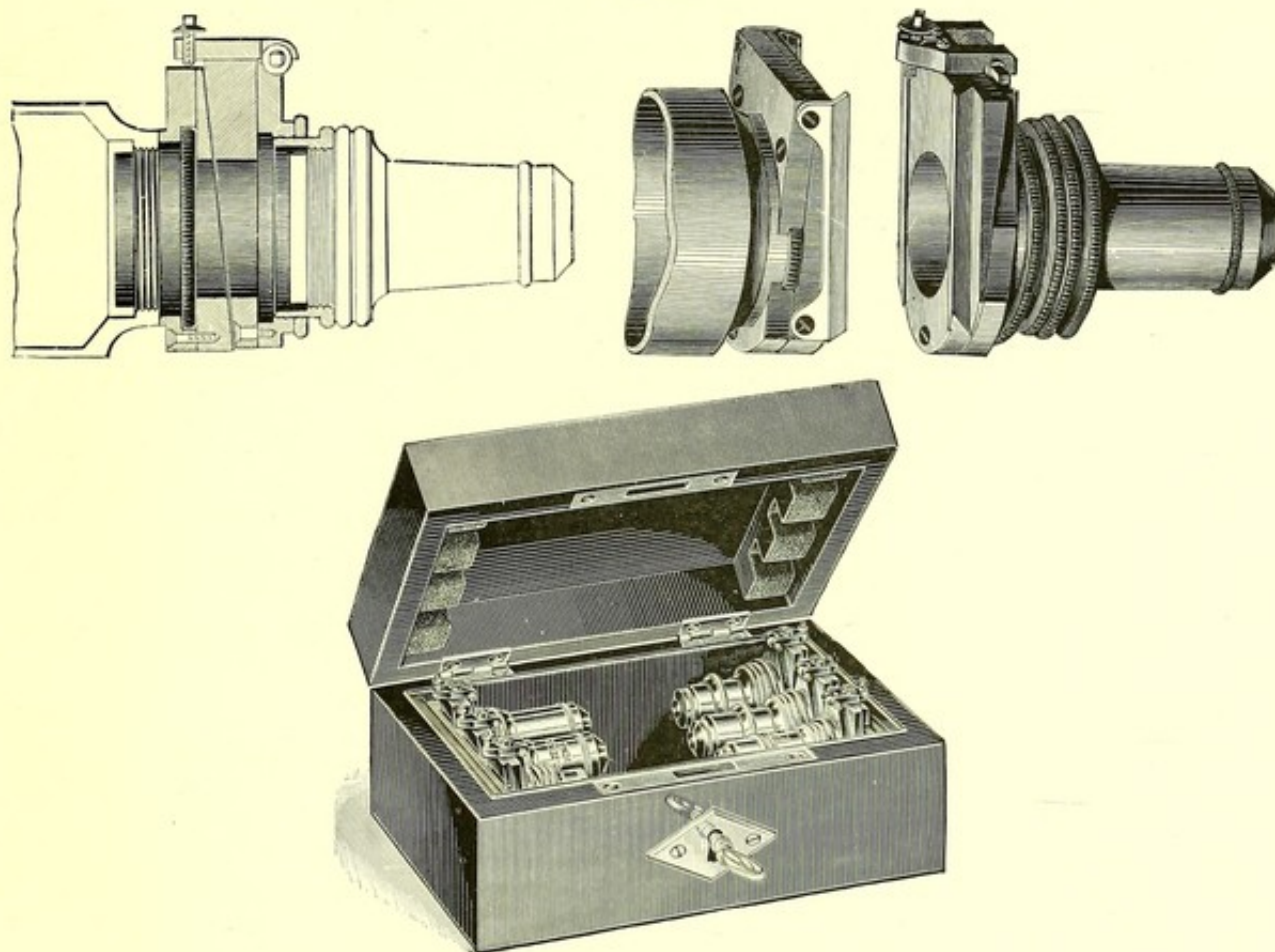

Zeiss Sliding Objective Changer

would be satisfactory ; but this it seems impossible to do, inasmuch as each objective always requires an adjustment peculiar to itself. It is to meet this difficulty the firm of Zeiss have introduced what they term their "Objective Changer" (Fig. 39). It consists of two parts, one attached to the microscope itself, which is never removed, and another which is fixed to every objective.

When a change is desired it is only necessary to slide one objective out and

another in. The portion separately attached to each objective is supplied with two adjusting screws, which enable the microscopist to move the objective from side to side or from above downwards. This adjustment is done once for all, provided the objective be not removed from the holder, when perhaps readjustment may be necessary. The convenience of such an appliance must be experienced to be appreciated, but a word of caution is necessary in centring objectives with these changers, and it is this: Seeing that each objective can be moved from side to side or from above downwards in its holder to a sensible amount, it is quite possible so to shift the objective that the object is unconsciously viewed almost entirely through its

Fig. 40

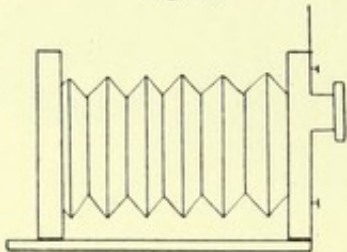

Camera with lens pushed up

outer zones only, instead of along its optical axis. The consequence of this is that the perfection of definition may be seriously interfered with; just as if with an ordinary photographic lens and camera a photograph was taken with the lens pushed up or down in the sliding front, and the photograph taken with the marginal rays instead of the central ones (Fig. 40). The way to avoid

this mistake is to adopt the following plan. Let us suppose the microscopist is desirous of centring several objectives for the same microscope. Having secured a sensibly sized diatom—one preferably with a well-defined edge and centre, such as one of the *Arachnoidiscus* type—let it be placed on the stage of the microscope, and a $\frac{1}{2}$ inch objective (as it comes from the maker) screwed into the nose-piece of the microscope tube in the ordinary fashion. The diatom is then fidgetted about on the stage until it is practically central in the field of view.

This power is then removed and the highest objective of the battery placed in its stead, say, for instance, a $\frac{1}{2}$ th immersion. Having again focussed the diatom, its central position is brought accurately into the middle of the field and the objective removed. The “body portion of the changer” is now affixed to the microscope tube and the other portion of it to the $\frac{1}{2}$ th, and the two united by sliding them together. The diatom by our previous experiment was placed central with the axis of the tube, and it only now remains to see whether it is still so placed. If not, it must be centred by the adjusting screws on that portion of the changer attached to the objective, and *not by moving the diatom*. Each objective must be centred by its own changer in the same way the diatom remaining untouched throughout. To make our meaning clear, the first portion of the description deals with the method of getting the diatom in the axis of the tube of the microscope, the second shows how to make the axis of each

objective central also. It is very obvious that the lenses will now perform at their best, for every object will be axially viewed by each objective.

The Davis Diaphragm.—Before quitting the subject of lenses, we must mention, as perhaps the most suitable place for so doing, that it is very useful to have placed in the microscope tube, just above the objective, an auxiliary iris diaphragm. It has been called the Davis diaphragm. Its object in this position is to very slightly curtail the marginal rays of low-power objectives, by doing which even with apochromatics a better definition—one full of greater contrast—is often obtained. Any reflections too from the side of the tube may be cut off by this means. It should be made truly central with the axis of the microscope and should be in no wise closed when using lenses of high aperture; for if such should be done—seeing that resolution entirely depends upon the numerical aperture of the lens, as already hinted—the wide-angled objective becomes a narrow-angled one and will cease to possess its separating power.

(iv) **The Mechanical Stage.**—It is a great convenience, indeed almost a necessity, for the microscope to have a mechanical stage. It must be well made and possess verniers, so that when objects are once found and noted they can be brought again into the field of view without any trouble. It is better for the stage to be capable of rotation about the axis of the microscope, and such motion is a great convenience, for at times specimens are not placed upon the slide in a position favourable to photograph them without they are turned on their axes to the right or left. If no rotation of the stage is possible, the object itself has to be moved, which, when employing a high-power, frequently causes it to pass out of the field of view, thus necessitating time and trouble to find it again. Should, however, the expense involved in having a rotating stage be thought undesirable, still a mechanical one should always be obtained. Even this is costly, but that can be got over by employing one of the many forms of *removable stages* that are sold by most opticians which are not so costly. To a great extent these are all made after the Mayall model, which has one rack and one endless screw. None of these last so well as the ordinary type of permanent mechanical stage as met with in the best microscopes, for the endless screw soon shows sign of wear, and the loss of way rapidly becomes very annoying. To obviate that Messrs. Baker, of Holborn, have quite recently brought out a new model which only requires two screws to attach it to any ordinary stage. We have examined it carefully and can recommend it, as it seems likely to wear well, having no endless screw in its construction, and besides, it allows considerable movement in both directions, each of

which is graduated to millimetres. Through the kindness of the firm a block of the arrangement is given herewith, which explains itself, Fig. 41.

Fig. 41

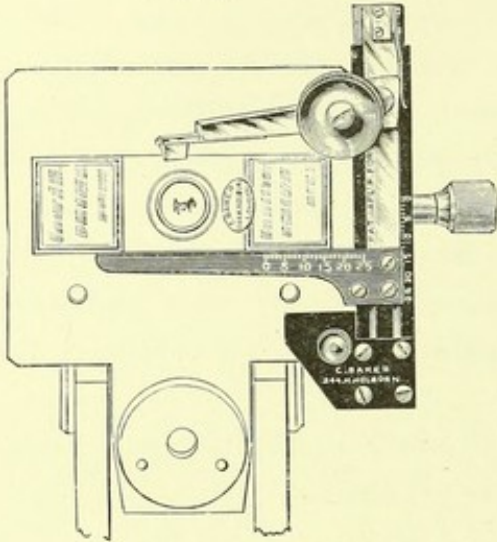

Baker's Removable Stage

Fig. 42

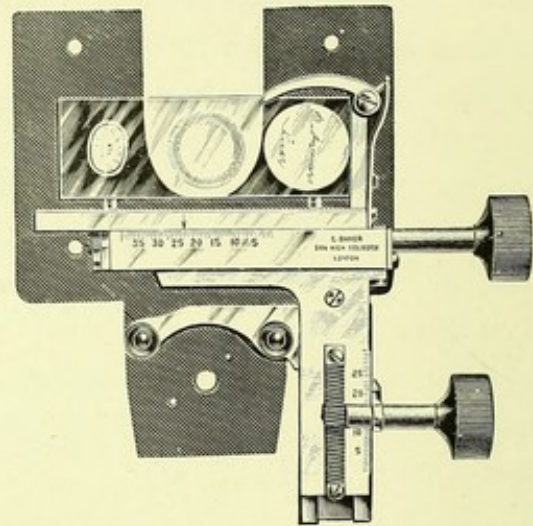
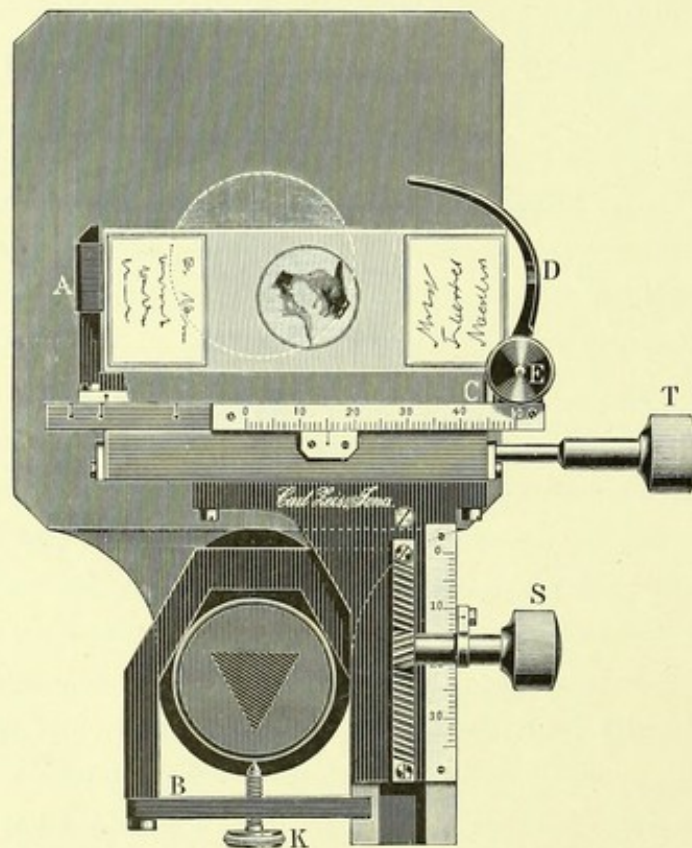

Fig. 43



The Mayall pattern, to which we have referred and which is still much used is shown in Fig. 42, as made by Messrs. Baker, and in Fig. 43, as sold by Zeiss.

(v) **The Movable Substage.**—This stage is for the purpose of holding the substage condenser. In most forms of microscopes it contains the means of producing up and down movement as well as side to side in all azimuths. It is well seen in the illustrations of microscopes already given. But in the Zeiss pattern the arrangement is different. The condenser, Fig. 55, is itself contained in a self-centreing jacket and the whole mass is dropped into a sleeve on the substage which is only capable of being made to move up and down. This is not desirable, indeed the substage arrangements of the Zeiss model are its weakest point, for it is obvious that without *special arrangement* no other condenser can be substituted for the Zeiss pattern on account of the fact that all English models are made of *lens* pattern, much smaller than the Continental, and are not sold in centreing sleeves at all. In our own case, to use the Powell and Lealand condenser, we were obliged to have made by Beck & Co. a special self-centreing arrangement to carry any condenser, as all the English ones are made with the universal thread, the same in fact as the thread of the objectives themselves.

It is a good addition for critical work to have a fine adjustment to the substage to produce extremely delicate movements up and down. Several of the figures shown have this, but it is absent in the Zeiss models, which is a subject of regret to the photo-micrographer, and we are desirous of calling the attention of the firm to the subject.

SECTION II.—(i) SELECTION OF OBJECTIVES

LENSES are of two kinds, the **achromatic** and the **apochromatic**. The former have been in existence for years and are being slowly and steadily improved both in quality and definition, whilst the latter are of more recent invention. So far as the superiority which the apochromatics possess over the achromatics, there is no possible room for doubt, but seeing they are so very much more expensive and that achromatics of recent years—since the introduction of the Jena glass—have reached to so far a greater pitch of perfection than formerly, it will be advisable to discuss the use of both kinds.*

The Achromatic is built on an entirely different principle to the apochromatic, for even in the best makes, the inevitable residual colour of the secondary spectrum is always well marked: indeed, with this type it is impossible with our existing knowledge to entirely remove it. Opticians have striven for years to improve their general performance, but achromatics have undergone a decided advance quite

* It may interest the reader if he cares to go further into the subject, to read an article by the author in the "Annual of Microscopy" for 1898, published by Percy Lund & Co., "Achromatics *versus* Apochromatics."

recently in the hands of Mr. Conrady. We have only been able to test a few of the lenses, because his series is not yet complete, but those that have been tested show, besides an excellent performance on all the recognised test objects, a very great excellence in one particular, and it is this: The ordinary achromatic will not stand eye-piecing beyond five or seven diameters at the most without producing what is technically known as a "rotten" image, but the objectives in question will work easily with ten, and, using suitable objects, even with an eye-piece having the initial power of magnifying eighteen diameters. Here we have, then, a decided improvement, and we understand that it is dependent upon an entirely different line of thought in their construction. Mr. Conrady considers, *ceteris paribus*, that the *real* improvement in the construction of achromatics of the future will lie in the careful uniting of equal *phases* of the rays to be joined in one focus, and inasmuch as his results so overpower those hitherto obtained, his theory, although not easily grasped, may be worthy of the most careful consideration. Notwithstanding what has been said, some very fine lenses do already exist, such as No. 2, by Leitz, Nos. 6 and 7A, by Reichert, the $\frac{1}{6}$ th immersion also by Leitz, and what used to be called the **semi-apochromatics** by Reichert, let alone some excellent objectives recently brought out by the old-established firms of Ross, Beck, Wray, and others.*

But before making a selection we must first pause to consider how we are going to photograph *at all* with a visually constructed objective. Let us suppose, for instance, we put a visually constructed inch on to the microscope, focus, and take a photograph. We should find that although focussed on the ground glass so carefully every structure was absolutely out of focus on the plate. The reason of this is not far to seek. Microscopical objectives computed for visual use are all constructed to give their image by the union of the yellow or yellow-green rays of the spectrum, because the eye perceives this colour more powerfully than any other, hence it is obvious, inasmuch as each colour in the achromatic brings its image to a focus in a different plane, that if we focus in yellow the image produced by the violet rays

* Whilst these pages are passing through the press, we have had two more new lenses to critically examine, one, an $\frac{1}{4}$ th immersion by Swift and Son; and another, a $\frac{1}{2}$ th immersion sold by Baker, of Holborn.

The $\frac{1}{4}$ th by Swift is an admirable lens and very well corrected for colour. As an achromatic we have no hesitation in saying that its performance leaves little to be desired. Its N.A. is 1.25, and it is very cheap. It is a fair photographer.

The $\frac{1}{2}$ th immersion sold by Baker is perhaps the finest $\frac{1}{2}$ th achromatic lens we have ever seen. It rivals a true apochromatic, and with low powers none but an expert could distinguish it from one built upon that principle. Its correction for colour is amazingly good, whilst its defining power leaves nothing to be desired so long as high eye-pieces are not employed. We think the lens has a great future before it, and we most heartily congratulate the firm upon being able to sell it at such a moderate price. Its N.A. is over 1.30, probably about 1.33, which for an achromatic is perhaps the highest obtainable. Photographs taken with it—provided a monochromatic screen be employed—compare very favourably with those produced by apochromatics.

(which are those used in ordinary photography) will be outstanding at another point on the axis. In ordinary photographic lenses this trouble is got over by uniting with the yellow some portion of the violet end of the spectrum, so that when we focus in the yellow we unconsciously focus in the violet at the same time. By this means it is very evident, if the optician has done his work well, our *visual* focussing will produce a sharp picture on the negative, although taken in reality by the violet ray. There is only one practical way of getting over this difficulty—using visually corrected objectives for photo-micrography—and that is to photograph in monochromatic light and to use a correspondingly stained plate. Yellow light is by far the best, and it works well with the Edward's isochromatic plate; but what we think much better is to do away with the visually corrected achromatic altogether, and to alone employ objectives *corrected for photography*. Wray sells an excellent series, and we have often obtained with them the very best results, and with some specimens, when using low-powers, *so good as to be almost indistinguishable from those obtained by the use of apochromatics*; although this is not usual unless the object photographed be one with coarse detail, and so not require high N.A. to resolve it.* Those, therefore, who must content themselves with the cheaper form of lenses, are strongly advised to buy *achromatics especially arranged for photography*, although they are of very limited use for serious visual purposes. The reader may think this not a little curious, for what can be brighter and more crisp than the image produced by a good photographic lens? But the fact is, the corrections that have to be applied to a microscopical objective are of a far higher order than those which are sufficient for even the best of photographic lenses, errors left outstanding as negligible in the latter are of quite sufficient importance to destroy the best performance of the former. We must not omit to caution those who are commencing the subject not to be led away by purchasing *achromatics* said to be made for the twofold purpose, visual and photographic. There are optical reasons which must, both theoretically and practically, in the existing state of our knowledge we fear, forbid anything like perfection in these lenses for double use. At their best they are but a compromise, and so do not give the best of results for either purposes. To resume, however, if suitable screens be found and photo-achromatics of the highest order be employed, there are certain specimens such as tissues with *coarse* markings, that can be worthily shown by photo-micrography. We show one, Fig. 1, Plate III., that was taken with a photo-inch by Wray, and the reader must judge for himself as to the quality of the image.

* This term N.A. will be explained a little later on, see page 85.

The Apochromatic System, of which we shall now speak, is necessarily a very intricate one, for a very large number of lenses enter into the formation of one combination. They are therefore necessarily very costly, but the resulting effect is a perfectly colourless image of great excellence, brilliancy, and purity. Readers are warned to be exceedingly cautious in having *anything* to do with apochromatics which have been brought out of cheap design, claiming to be as good as the more expensive ones. We have examined most carefully one of this make, and found that it was *not* perfectly apochromatic, as stated, and that its N.A. was but slightly *over* 1.26, *although sold as* 1.40.

Photographically speaking, one great advantage of the real apochromatic system is that photographs can be taken in *any* colour, for all rays of the spectrum are sensibly brought to a common focus. It will be seen at once how very important this is, especially when dealing with objects of feeble contrast in colour, such as the bacteria of diseases. It may be mentioned that owing to their feeble staining, in some instances the only chance of making a good photograph is to use some coloured screen, whereby a colour contrast can be produced between a bacillus and its background. This done, a good photograph can be obtained provided the lens focusses the same in all colours, but it is equally obvious that if an ordinary achromatic were used the final result must of necessity—there is no discussing the matter—be greatly inferior. We have only to look at the photographs taken of these objects in past years by achromatics of the then highest order, and compare them with *similar objects* taken in the present day by means of apochromatics; the result speaks for itself.

The sum total, then, of the remarks on lenses comes to this:—When photomicrographs are desired of the very finest order and of high amplification, such as photographs of diatoms or bacteria at 1000 or 2000 diameters, nothing will give the perfection required save *the apochromatic used with its compensating eye-piece*; if, however, medium power work up to, say, 200 or 300 diameters, is the sole ambition of the photographer, then he may confidently rest assured his results will be worth looking at should he employ achromatics well corrected for photography.

It is an open question whether photographically corrected achromats should be used with an eye-piece or not. Personally we have no hesitation in saying so; but it is equally well known that in some photographers' hands with certain specimens, and certain degrees of magnification, excellent results have been obtained without. But a doubt still remains in one's mind even then whether better results still would not have been produced should an eye-piece have been used. With the *apochromatic* system, inasmuch as part of the final correction of the objective is obtained by the use of the

special compensating eye-piece, so it is absolutely necessary to use one with this type of objective, and of all the compensating eye-pieces the best results are usually obtained in photography with those specially designed for projection purposes. They are termed "projection eye-pieces." These, with suitable camera length, will nearly always fulfil the requirements of the photo-micrographer, but at times when he wishes over 1000 diameters to save extreme camera length, it may be necessary to put them aside and use the *ordinary* compensating eye-piece, as they extend so much higher in power, even up to 27 diameters. This it should be remarked is another superiority of great service with apochromatics; they bear eye-piecing to almost any amount without producing a "rotten" image.

Dry and Immersion Objectives.—Whether apochromatic or achromatic, objectives are of two kinds—"dry" and "immersion"—by which is meant that one is used dry as it comes from the maker, and that the other—to insure its best optical performance—needs a drop of cedar-wood oil or some other suitable fluid interposed between the front lens and the cover-glass of the specimen. Both these varieties must be explained, but to do so intelligibly it will be necessary to premise our remarks by considering for a moment, in as few words as possible and in a popular manner without mathematical detail, the subject of refraction of light.

Light is always supposed to travel in straight lines—"rectilinear propagation" as it is called. Bundles of rays issuing from an illuminant may not be parallel amongst themselves, constituting what is called diverging or converging light; or they may travel side by side with unerring rectitude—such as we meet with in the light coming from the stars or the sun—when they receive the technical name of "parallel light." The path of any ray in a given medium is always straight until it meets with another medium more or less dense than itself, when, with one exception, it is bent aside, undergoing what is called "refraction." After such bending, however, it will again resume its rectilinear propagation along its new path, until it meets with a fresh medium, when on entrance it will be bent again if the density be different. Change of density then *of the medium* is the cause of refraction, and this must be held in mind. It will be well now to briefly point out the nature of the alteration of direction brought about by the change of medium, and for purposes of description have resort to Fig. 44.

Let A B C D represent the outline of a circular vessel, A C being the water line, and B D drawn at right angles to this level passes from B to D through E—which direction is called the "perpendicular" or "normal," all angles being referred to this line. When the beam is incident along B to E perpendicularly into the new medium,

there is no refraction or reflection—the only instance where it undergoes no bending—for it passes on into the water, uninterruptedly following the course of the line $E D$. But when it is incident at any other position—say at m along $m E$ there is refraction at E , for the beam will be found to strike the point n . Suppose it is incident at m' along $m' E$, then there is also refraction at E , for the ray will be found at n' .

Snell made a celebrated investigation concerning this bending of the rays, by which their path can be predicted. Were it not for his discovery, about to be explained, we should not have had the grand computations of lenses with which, in the present day, we are all so familiar.

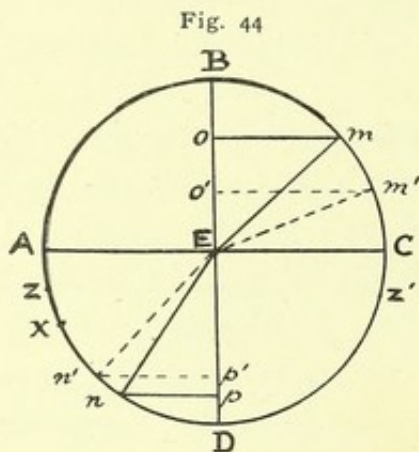

He first drew a line from m to meet $B E$ at o , and another from n meeting $E D$ at p . The lengths $o m$ and $n p$ were measured and divided one by the other; a quotient was obtained. Now what he discovered was the fact that wherever the angles were taken, whether from m or m' , the quotients, in all cases using water and air, came out the same, viz., 1.333. This was called the refractive index of water. Other

substances were tried, and each substance had its special refractive index. Flint glass, for instance, was found to be about 1.54 to 1.64, according to its manufacture, and so on with other substances, complete lists being found in all books upon the subject. If the reader be mathematically inclined, he will at once see these lines, $m o$, $n p$, really represent the sines of the angles $B E m$ and $n E p$ respectively, so that, continuing our precept, the sines bear certain definite ratios one with the other wherever the incident light striking E comes from; that is, the ratio between $o m$ and $n p$, which is about 4 to 3, holds good, whether the ray starts from m or m' . It is quite evident now that we can calculate where the ray will strike $A D$, after starting from any given point in $B C$. For example, let m strike E to make an angle $m E o$, say, of 45° . It is required to find the angle $n E p$, so that we can draw $n E$ correctly. We take out of the tables the sine of 45° , and find, roughly speaking, it is 0.7, and multiply that by 3 and divide by 4, which gives us 0.5. Resorting to our book again, we find 0.5 is the sine of 30° , so that 30° must be marked off from D to find the line $n E$. Although, simply put, this is the maxim which mainly pervades the optician's mind in constructing new lenses. As a matter of fact, the details become exceedingly operose in real calculations, as different colours are refracted at different angles, and the problem, where many lenses are concerned, becomes intensely

intricate. But the law underlying the calculations is the same from beginning to end. The same law reversed of course equally holds good when rays pass from the water into air, and when passing from one glass to another, although then with certain modifications.

One more remark on the subject yet remains to be said. Seeing that n' passing to E becomes refracted to m' , what happens to a ray starting about x ? It will pass into the air and graze along $E C$. If this be true what will take place if one starts still nearer A , say at z ? This ray cannot get out of the water at all and is said to suffer "total reflexion" at E , for it appears again at z' . There is one angle then, it is very evident, which is the last, that allows a ray to get out; this is called the "critical" or "limiting angle," and is known for all kinds of glass.

Let us now see how these remarks apply to our subject. Consider Fig. 45. Let C be the cover-glass, having a refractive index of about 1.5, and L the front lens of the objective. Also consider $A B$ an incident ray upon the cover-glass at B . As it enters a denser medium than air, according to our precept it must be refracted towards the normal $B N$ and follow the path shown as $B D$. When it arrives at D

(as in the case of what happens when using a dry lens) it passes into air again—a rarer medium so is bent away from the normal $D N'$ as much as it had been bent towards $B N$ the previous normal on entering the glass, thus continuing its course along $D E$ to E ; $D E$, therefore, is of course parallel to $A B$. It will now be readily understood, without much consideration, that any rays lying between $D E$ and the edge of the objective (where $D E'$ touches it in the diagram) will be lost to the microscope, as they have no chance of entering the front lens of the objective.

But let us consider what happens if we place between the lens and the cover-glass a drop of fluid, say, cedar oil, which has the same refractive index as the cover-glass itself, viz., 1.5. Follow the diagram, commencing at the right hand, and consider the ray starting from A' . Arriving at B , it will be refracted to D' just the same and for similar reasons as $A B$ was refracted to D . But notice now what happens. As the emerging ray at D' enters a fluid of the same refractive index as the substance it has left, it continues its path uninterruptedly in a straight line to F , which enables the

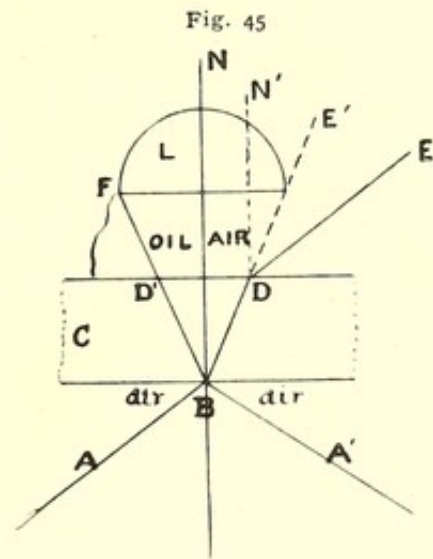

object-glass to gather up the whole of the rays that were lost when the ray entered air, as shown on the other side of the diagram instead of the oil. *It is obvious, then, why immersion lenses give so much more light.*

The same class of reasoning holds good with the mounting media of specimens. If they are mounted dry, which means in air, many diffractive beams which pass from the object, all of which, theoretically, if it were possible, should be caught up by the objective, are lost; whereas, if mounted in Canada balsam (refractive index, 1.5), many more may be caught.

It is very obvious, then, that, theoretically, dry objectives cannot pass so much light as immersion ones, and this is practically found to be correct. What is more to the point, the argument also shows that *the limit of dry objectives is N. A. 1.0*, because all the outside rays will be lost without the interposition of some homogeneous substance to optically join up the gap between the objective and the cover-glass. It is for this reason that immersion lenses are often called homogeneous systems.

Another point not to be forgotten is that as the cover-glasses vary in thickness and density, so the bending of B D may vary in direct accordance, and it is to obviate this that dry lenses of high N. A. are provided with a "cover-glass adjustment," which so regulates the performance of the objective as to accommodate it to the differences in question. To practise the user to arrange the adjustment, as well as for other reasons, the firm of Zeiss sell a slip upon which several cover-glasses of known thickness are placed, and as the firm mark the adjustments for different thickness of cover-glass on the objective itself, it enables the beginner to practise over and over again the art of getting his adjustment correctly by sight, and then proving his result, until he is quite an adept, by comparing the figures on the cover-glass with those on his objective. This object lesson, which requires some patient practice and learning, is of great service, especially to the photo-micrographer, as it will be seen hereafter when speaking of depth of vision in lenses (page 87). It will then be shown a great deal of accurate vision is dependent on the accommodation of the eye—hence the greater amount of accuracy in focussing, &c., is required when photographing an object where the accommodation of the eye does not come into play, and every adjustment to improve such focussing must be employed.

Inasmuch as the presence of the cedar oil forms a homogeneous system, so it is obvious that any small variation in thickness of cover-glasses does not make any difference; hence the majority of immersion lenses have no cover-glass adjustment. Messrs. Powell & Lealand, however, still consider that, notwithstanding what has been said, the very finest of definition under certain circumstances may be only

secured by a touch of a cover-glass adjuster, so they provide their immersion objectives with them. Great care must be exercised in using all immersion lenses for they are delicately made, especially as the power increases, by which is meant that the greater the N. A. the more care must be used. This is made obvious by the study of Fig. 46: on the right is an objective with N. A. 1.30 and the left one of 1.40 (after Zeiss.)

Dry lenses which are not provided with a cover-glass adjustment have to be corrected by pushing in or pulling out of the draw-tube of the microscope, which optically amounts to almost the same as the use of the cover-glass adjuster, *lengthening* the tube with thin cover-glasses and shortening it with *thick* ones.

The careful reader will now very readily

understand what is meant by modern objectives having written upon them very plainly—"For 170 mm. tube" or perhaps "Tubuscule 250 mm.," and so on—it is the length of tube for which the objective has been originally corrected with a given thickness of cover-glass. Each maker has his standard thickness of cover-glass, and this can be furnished on application. With low powers all these minutiae vanish to a great extent, but when dealing with high-power dry objectives they become of the *most paramount importance if perfection of result be aimed at in the final photograph.*

(ii) **Numerical Aperture.**—This term has often been used, and its usual expression is by the letters N. A. The N. A. of a microscopical lens bears the same relation to its performance as the aperture of a telescope does to that instrument. Astronomers full well know that the larger the object-glass becomes, the greater power the instrument possesses for separating close "double-stars." To put it another way, some stars which with a small telescope appear as single are easily separated into "doubles" when sufficient aperture is employed. Increasing the diameter of their object-glass yet more, perhaps one of the "doubles" itself, is found to consist of two, and it is no hidden fact that the higher the diameter of the telescopic objective the more "double stars" are found to exist. This is not the place to discourse upon the

Fig. 46

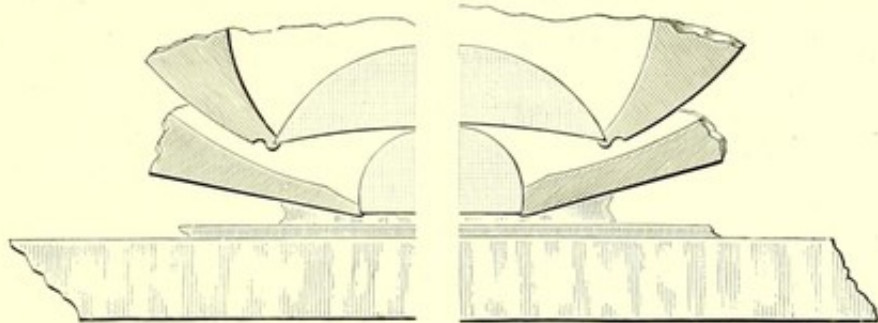

optical causes of this well-known fact ; indeed, it would be foreign to any article on photo-micrography, but it serves to illustrate what N. A. really is to the microscopical objective. The higher it is the more can be seen ; and the less you have, the more objects seem to blend themselves into a state of indivisibility. Opticians, therefore, have striven to obtain the highest degree of N. A. possible for each objective. The *higher* the magnifying power, the more easily is this obtained, and we regret that so many opticians understate the magnifying power of their lenses, so as to gain a repute for making wide-angle objectives. For example, it is fairly easy to make a $\frac{1}{2}$ th of moderate N. A., and sell it for a $\frac{1}{8}$ th of *high* N. A. It is a fraud, but it is often met with. With apochromatics manufactured by Zeiss, and Powell and Lealand, the foci given by the makers may always, without exception, be regarded as truthfully exact. The consequence of this is that the value of the magnifying power of any of their objectives is readily known, and this is of no small service in ascertaining how much the photo-micrographer has magnified his object ; but to this we shall refer again when a suitable occasion arises. A practical point the photo-micrographer should bear in mind is to always obtain, speaking generally, an objective with as high a numerical aperture as he can, for a $\frac{1}{6}$ th which magnifies 60 diameters with a low N. A. is not comparable in its powers of resolution to a $\frac{1}{4}$ th of high N. A., although it amplifies 20 diameters less. Magnification, therefore, is not so important—it can be got by camera-length or eye-piecing—as numerical aperture. In Figs. 10 and 11, Plate III. are two pictures, one taken with a lens of low N. A., and the other with an objective of high angle, the magnification being the same in both cases. One shows the dots plainly, the other hardly at all.

But from what has been said it would appear that low-angled objectives are of no use whatever. This is not the case. Seeing that although the *depth* of focus—which means the power possessed by the objective of viewing simultaneously *several* planes of focus—varies inversely as the square of the power, still it also varies as the reciprocal of the N. A. ; so that the less the N. A. the more the *depth of focus* obtainable.

Depth of focus used to be thought to be a distinct property peculiar to the best objectives, but now that the philosophy of microscopical optics is better understood, it is recognised not to have a separate existence of its own devoid of explanation, for it is known to directly follow as the result of lowering the N. A. As therefore the highest resolving power rests with lenses of the highest N. A., so the converse equally holds true that the less the aperture the less the objective can resolve, but the greater

is its depth of focus. It would seem now still more than ever apparent that the day for low-angled objectives is gone, but we again repeat this is not quite the case, for when it is desirable to take in at a glance the entirety of the dimensions of an object, its height, depth, and width, and the place it occupies amidst others that surround it, we may find it far more enlightening to use a low-angled objective with plenty of depth of focus. It is better, we may find, to sacrifice the ideal in *definition* so as to obtain a more *realistic* picture—one of greater utility and instruction, seeing it would enable the eye of the observer *at a glance* to perceive the perspective and realise *the general relations of the part to the whole* than would be obtained in the case of the *mental image* only derived by *differentially focussing first one plane and then another*, as must be done with a high-angled objective.

This is true so far as vision is concerned, but when wishing to photograph what we see, the effect of a low N. A. and depth of focus may be even *more* apparent, for when visibly we inspect an object in the microscope another factor enters into the problem, to which at present we have only referred some pages ago (page 85)—*the accommodation of the eye itself*. According to Professor Abbe, it assists very largely the performance of all objectives so far as relates to their depth of focus; but when *taking a photograph* there is no eye to assist, hence what appears well in focus to the observer, *may* not be so in the negative, for no amount of dexterity will give to the plate that part of the depth focus which *has been due to the eye*. Consequently objectives of *low* aperture may be even of more use to the photo-micrographer than to the visual observer.

Each type, then, of lens has its duty to fulfil. But if the reader is limited to the purchase of one kind only, we again state our conviction that the high-angled lens is that to be selected.

Shutting the iris diaphragm below the condenser is known to practically reduce the N. A. of the objective being employed, hence the question has been asked, If this is true, why buy low-angled lenses at all? It is because the image produced by closing the iris is not equal in truth or efficiency, owing to diffraction phenomena, to that given by a low-angled objective made as such.

Owing to apochromatics performing so well with any eye-piecing, anyhow, up to 27, or even more under certain conditions, this type of lens is not made of very low angle, for one which does not possess a great N. A. can be eye-pieced to give the required magnification, and so the depth of focus so far as results from the low N. A. can thus be obtained.

Seeing that the numerical aperture is of such importance, it must now be pointed

out to the reader how he can learn to ascertain this for himself in any given lens before he purchases it.

There are two methods for dry objectives, but only one for homogeneous ones.

The first, applying to both types of lenses, is by using a special apparatus devised for the purpose by Professor Abbe, called the apertometer (Fig. 47). This consists of a piece of thick glass about 3 inches in diameter, half an inch thick. The part where the glass becomes segmental is bevelled from above downwards to an angle of about 45° . Near the centre (marked a) is a small disc of silvered glass with a tiny

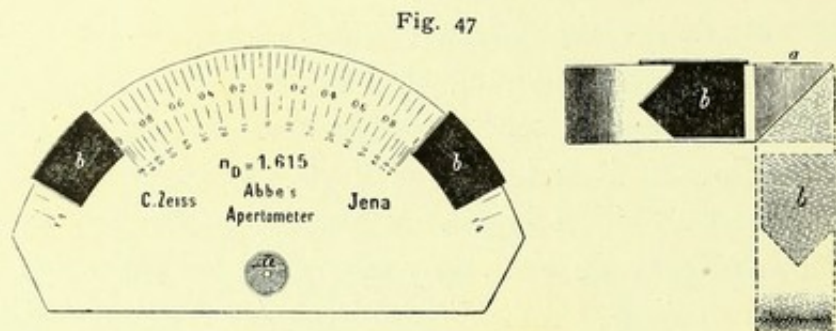

hole in its centre, where the silvering is removed. Two plates of metal, which can be shifted around the outer edge of the glass shown at *b b* are square one side and pointed on the other (see *b* in the side view). To use this apparatus, the glass is placed with the graduated surface uppermost upon the stage of the microscope (fixed vertically) in such a manner that the circular portion is forwards and the chord or bevelled piece backwards, towards the stem of the instrument. The edges of the little hole are now focussed with the objective to be measured, an eye-piece being used, and the length of the draw-tube the same as when the objective is ordinarily in use. The two indices, as *b b* are called, are then placed on the edge of the glass, as shown in the plate, but close to the middle of the semi-circle. Their sharp points should lie along the vertical edge of the disc, and their flat sides upon its upper graduated surface. It is best to direct the points away from each other to the outer side, if the power to be examined is comparatively high (N. A. above 0.6 or 0.7), but towards each other to the inner side if a low objective is employed.

With each instrument an auxiliary objective is supplied which screws, or must be made to screw, into the end of the draw-tube, after which both are returned to the microscope, with the auxiliary lens passing down the main tube. The same eye-piece is then placed in the draw tube as before, and the auxiliary microscope then obtained is focussed to the image of the indices by sliding the draw tube in the main tube.

Care must be taken both in pulling out and pushing in the draw tube *not to alter the adjustment of the objective under examination* by accidentally shifting the main tube.

The indices are now adjusted, taking care they lie close to the glass plate until their sharp points just touch the periphery of the luminous circle seen on looking down the eye-piece. Their position found, the readings of the upper edges, which lie in the same vertical plane as the points, are read from one of the two scales on the plate. The half of the sum of the two readings on the outermost scale—that nearest the edge—will give the measured value of the N. A. of the objective under examination. Likewise the sum of the two readings on the inner scale will give the value of the angular aperture in air.

The illumination must be shifted from right to left or up and down, so that the light falls horizontally upon the edge of the glass.

A note should here be added to which attention is not sufficiently made in the Instructions we think.

If the apertometer be used on *low*-power objectives or on condensers such as a half-inch, *but with high N. A.*, owing to the size of the back lens having to be so large to bear its necessary ratio to the front one which is itself also large; so the *auxiliary* lens (which we think too small) may not be of sufficient angle to give the maximum N. A. of the objective under examination. Also, and this is commoner still, it is not at all improbable the ordinary eye-piece, whether achromatic or apochromatic, may not command sufficient field of view either; so between the two troubles a false N. A. may be placed upon the low power objective or condenser. This actually happened in our case when testing a condenser of high N. A. and an apochromatic half-inch—both estimations came out too small. The mistake was discovered by applying the next means about to be described for ascertaining the N. A. of an objective which gave us such different results. To remedy the evil with the apertometer, let the observer look down the microscope after the first focussing (doing away with auxiliary lens), and regulate the indices without an eye-piece at all.

Special instructions are given with each instrument, but lengthy as the description must necessarily appear, the apparatus is not difficult to use, the only fault is its expense. Still it is the only plan with immersion objectives.

With dry powers, however, a simpler method of obtaining the approximate N. A. may be employed, and as it is not to be found in any text-book that we are aware of, we will describe it in as few words as possible.

Lay upon the table two pieces of white paper, using a black background, with

their straight inner edges parallel to one another, and a definite distance (say 20 centimetres for lenses of N. A. over 0.50, less for low-angled ones) apart, then hold a rule vertically upon the table about midway between the two pieces of paper. Next hold the objective to be tested vertically against the rule and look down at the back lens. Images of the two pieces of paper will be seen there; now slide the objective downwards along the edge of the rule, always watching these images. They will separate farther and farther apart until at last a point is reached where only a slight bluish flicker remains visible on either side in the extreme margin of the lens, which, of course, indicates that the inner edges of the pieces of paper are in the direction of the most oblique rays which the objective is capable of receiving, or that the angle enclosed between these directions, (which directions intersect in the principal focus of the objective), is the **angle of aperture**. To determine this angle, read off the distance from the table to the *front* of the objective, and subtract the working distance of the lens, so as to get the distance from table to focus. Then this distance divided by half the distance between the two pieces of paper is the cotangent of the semi-angle of aperture; the latter may, therefore, be obtained from a table of trigonometrical ratios, and the sine of the same angle is the N. A. of the objective.

EXAMPLE :

Distance between the two pieces of paper, 200 mm.

Distance of front lens of objective from paper, 33.0 mm.

Working distance of objective, 0.2 mm.

$$\therefore \frac{33.0 - 0.2}{200/2} = \frac{32.8}{100} = 0.328$$

0.328 = cotan of angle $71^{\circ}49'$, as we find from the trigonometrical tables, the sine of which angle = 0.95 = N. A.

With great care this method will give results accurate to one or two units of the second decimal. In looking at the back of the objective the eye should be placed at a distance about equal to the tube length for which the objective is designed, but the error caused by even considerable deviations from this theoretically required distance is very small.*

(iii) **Eye-pieces.**—With respect to eye-pieces or oculars, as they are often called,

* For this method the author is indebted to Mr. Conrady.

little need be said. Achromatic objectives require one sort, the ordinary Huyghenian, and apochromatics another which are called "Compensating" because they complete the colour correction of the objectives. For low-powers the best form for either work is what is called "a projection eye piece," but for magnifications that reach to thousands of diameters in the case of apochromats the high-power compensation forms must be employed. They can be obtained as high initially as 27. One point the photomicrographer should never omit to guard himself against, and that is, the accumulation of dust in the oculars: they not only lessen the amount of light but seriously spoil the final performance. There is a certain class of dirt which settles on the lenses not very evident until a photograph is taken, when it will appear as a kind of ill-defined dot with a bubble-like periphery. The lenses often require to be cleaned with spirits of wine to remove the source of trouble and a *well-washed* chamois leather kept in a stoppered bottle should be at hand for this purpose.

CHAPTER V

THE SUBSTAGE AND AUXILIARY CONDENSERS AND OTHER MATTERS
OF IMPORTANCE FOR BOTH MEDIUM AND HIGH-POWER
MICROGRAPHY.

THIS chapter contains a full description of the following :

- (i) Substage Condensers and how to centre them.
- (ii) "Critical Light," and the "Critical Image," how to obtain it and its use.
- (iii) The auxiliary Condenser, and how to centre it.
- (iv) Monochromatic light—its use.
- (v) How the heat of the illuminant is kept from the microscope and the specimen.
- (vi) A description of a convenient form of exposure-shutter.

(i) **Substage Condensers and how to centre them.**—The primary object of the substage condenser is to collect light from the illuminant and concentrate it upon the object. It consists of a system of lenses which form a cone of light, the apex impinging on the specimen, and when thus used, without any stop, the object is said to be illuminated by a "*large solid cone of light*." But if an iris or other diaphragm contract the aperture of the condenser, the base of the cone is reduced in diameter, and the object is declared to be illuminated by a "*narrow solid cone*." If a stop—say of a piece of cardboard, or preferably a piece of metal—be placed in the base of the cone so as to prevent all rays passing through its centre, the object has then a *hollow cone* of light impinging upon it, and is said to be illuminated by "*annular light*."

Condensers, like objectives, are capable of being made of different foci as well as of different numerical apertures, and also of being constructed chromatically, achromatically, or after the style of the apochromatic objective, when they are called chromatic, achromatic, or apochromatic, respectively. The ordinary so-called Abbe condenser is a chromatic one, and of no use in photo-micrography. It is a poor form of condenser at the best of times, and from a scientific point of view we have often

wondered how its use has ever been adopted in this and other countries in the manner it has, but possibly the words of Dr. Dallinger sufficiently explain it when he says: "The fact is that a large part of the admiration that has been expressed for this condenser has resulted, not from a comparison of its results with those of other high-class achromatic condensers, but of images obtained without any substage optical arrangements at all, placed in contrast with the results obtained by using this condenser against the same objective when used without its aid."

A microscope without a condenser is not a microscope at all in these days of perfection, and those who declare that with medium-power photo-micrography no condenser at all is required are mistaken, that is, if they desire to obtain perfection of result.

Condensers, theoretically, should be of the same N. A. as the objective, even to 1.40, but, practically, it is not of so much service if they are, as no objective—excepting when employed on bacteria—that we are acquainted with will stand a solid cone of light from the condenser the same size as its own N. A.

If one should be so constructed we should look for much greater perfection of the final image, but at present even the Zeiss, and Powell and Lealand apochromatic objectives will not bear more than about two-thirds of the illumination of the back lens, as seen down the tube of the microscope on removing the eye-piece, when employed on objects in general, such as diatoms. It will be thus understood if we could obtain a really perfect condenser of about 1.0 N. A., it would practically illuminate, at its full solid cone aperture the amount required to about fill a 1.40 N. A. objective so far as necessary; and observers who have tried a condenser of higher N. A. than this, without prejudice have expressed their belief that inasmuch as the higher N. A. has to be cut down to fill only two-thirds of the objective, the advantage gained by the high-angle condenser must be lost. And although some who read this may doubt the truth of these remarks, they seem based on careful observation, and after all are only rational deductions. Let two photographs of subjects other than bacteria, for example, be tried, as we have known, one with a 1.35 N. A. condenser cut down to the necessary aperture, and the other when using a 1.0 N. A. condenser with its full aperture; the difference between the results, if using direct light and solid cones, have appeared to be indistinguishable.

But when employing the microscope on bacteria—by which is meant when photographing them at high magnification—a full cone of light must be employed, and here it *may be found* of service to employ a high N. A. condenser, because it shortens exposure, and, in some cases, may sharpen the general aspect of the bacilli. If a small solid cone be employed, by closing the iris, a *white diffraction ring* will be

photographed around each little object, which will quite spoil the final result. Then again, when using what is called "oblique light"—that is to say, when a diaphragm is placed eccentrically in the base of the condenser, so as to limit the light entering it to one small edge of the back lens, thus passing obliquely on to the object—then, too, is the higher aperture of the condenser to which we have referred of definite use. It is obvious here why the extra aperture should be of service, as it necessarily permits a greater degree of obliquity of the rays passing to the object than would be permitted by one of smaller N. A. The application of oblique light as applied to photo-micrography will be given in a future place when dealing with objects which require its especial use, but mention is merely made to it here as connected with what we think is the real value of these condensers of high N. A.; that is, until objectives are made which will stand their use.

With respect to the hollow cones of light and their utility, much difference of opinion also exists. For testing and showing the inferiority of the outer zone of all objectives, even the very best of apochromatics, this annular light may be most advantageously employed by the optician, but we confess to agree with many who are more qualified to give an opinion than ourselves, that as to its increasing definition—except, perhaps, on the vexed question of how many lines can be resolved to the inch with a given aperture—is altogether a very doubtful and debatable matter. It is true those who are its advocates reply that it is only oblique light in all azimuths, and that is so; but to the use, except under special circumstances, of oblique light *at all* we beg to demur, for it is not difficult to show that it is a most dangerous experiment, filling the image with optical phenomena *perhaps in no way connected with the real details of the object itself*. It is, moreover, evident from the studies of Professor Abbe in recent years, that the final image afforded by the best of extremely high power objectives that can be made is not to be regarded as an *absolutely faithful* representation of the minutest details of the object in their final form, unless, indeed, the objective has a N. A. of about 2.00, and is used in conjunction with a suitable substage condenser and with an immersion fluid of sufficiently high a refractive index, all of which at present seem to be absolutely unattainable. Therefore, it is of very *doubtful* advantage to imperil the close approximation to the truth we already possess in the performance of our highest power objectives by adding to the final image produced by them a series of the minutest details, which in all cases *may*, and in many positively *are*, due to optical phenomena of the highest order of complexity—*false* images rightly called, indeed, and which are only of interest to the optical student, and which can be varied at pleasure. If *extreme*

oblique light be employed false images can actually be shown *outside a diatom*, and what can be more disturbing to the scientific mind than to see a photograph of an object with a well-marked additional image of one of its own edges—perhaps covered with dots—*lying actually outside the real image of the object itself?* There are several who have given as much attention and more to the use of both annular and oblique light than ourselves, and have abandoned the use of both unless they can make themselves *absolutely* confident that what they see *with its use* is nothing more than an emphasised and better defined expression of what less perfectly *can be seen without it*.

If any one is desirous of studying the effects of the use of annular light, whether visually or photographically, he may find the following method of much service to enable him to ascertain the diameter of the central stop to be placed in his condenser for each objective. Having centred the light, look down the tube after removing the eye-piece, and close the iris until it just equals the aperture of the objective, which is known by seeing the iris commencing to narrow the aperture of the posterior lens. Measure this aperture of the iris directly with compasses, and make the stop for the lens under consideration $\frac{1}{16}$ of that diameter. If this little stop be suitably supported on thin arms and placed just above, or resting on the edge of the iris itself, it will be found to leave an outside ring of annular light about enough to fill the outer zone of the objective.

For convenience, we may mention an arrangement that has been made at our suggestion by Mr. Mason, optician, of Clapham. It consists of a ring, as the ordinary stops are made, but where the three arms unite in the centre stop all the brass is filed away, save a sufficient amount to support a little projecting pin. Upon this pin any of the accompanying discs of brass can be dropped—and several sizes are supplied. This is shown in Fig. 48.

When condensers were first introduced, and before theoretical considerations were complete, they were racked up or down—that is to say, within or without the focus—so that the image of the edge of the flame was avoided. An even illumination was then thought to be of far more consequence. The “Carpenter” school used to say the better effect was always produced by racking without the focus, whilst the “Quekett” disciple stoutly maintained it was just the reverse. Now-a-days we know that for critical definition Sir David Brewster was correct when he pointed out that “the source of light should be focussed by the condenser on the object.” Great authorities like Mr. Nelson and others in the present day have proved this assertion beyond all possibility of doubt.

Fig. 48

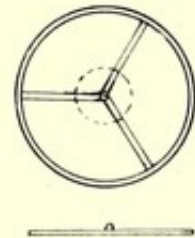

So far as relates to the various "cones" of light given by the condenser, terms which should be remembered as they are often referred to later on, it yet remains to briefly describe, sufficiently for the purpose of the photo-micrographer, the general optical construction and other considerations concerning the condenser as well as to show how to critically examine one.

It has been already said that condensers are manufactured of different foci, which is true, and some are made so that by unscrewing the top lens the lower portion can be used for lenses of lower N. A. Personally speaking we prefer those specially made for low angles; it is certainly too often true that by unscrewing the top lens the remainder only becomes a makeshift, and, as Dr. Dallinger remarks: "when the highest class of work has to be done *it is needful to have condensers suited to the power of the objective used.*"

The leading points to consider in a condenser are:

1. The focus.
2. The numerical aperture.
3. The size of the aplanatic cone.
4. The definition.

1. With respect to the length of focus, this is usually given by the makers, but may be roughly obtained by allowing parallel rays, say from the sun, to fall upon the back lens of the combination, and having focussed the sun's image on a piece of paper, by ascertaining the distance this point of focus is from a plane midway between the front and back lens. The method is rough, but accurate enough for the purpose. But the question is, what are the best foci for different lenses. This is much a matter of opinion. Some consider it should be approximately the same as that of the objective whereas advocates can be found that think it should be less; anyhow its working distance must be such as to allow *a slip of reasonable thickness to be employed.*

(In testing condensers for N. A., the thickness of the slip for which the condenser is designed must be carefully known, for if not a mistaken quantity may be obtained by the apertometer, and manufacturers may have misrepresentations made about their work which are not deserved.)

The focal lengths mostly chosen are for immersion condensers about $\frac{1}{2}$ inch: for high powers with N. A. about 1.0 between $\frac{2}{3}$ and $\frac{3}{4}$ inch: for medium powers about N. A. .6 say $\frac{1}{2}$ inch: and for quite low powers about $\frac{2}{3}$ to 1 inch focus.

2. To ascertain the N. A. it is only necessary to employ the Abbe apertometer in the manner already described (see page 89, under **note**).

3. To ascertain the amount or rather the size of the aplanatic cone is quite another matter. First, what is meant by an aplanatic cone? It is a term often used but rarely explained on account of the somewhat involved nature of the reply. The word itself, derived from the Greek, means, in point of fact, "free from wandering," by which the optician understands (as he uses the word) that all rays, whether from the periphery of the lens or nearer its axis, shall meet in one point in a given plane, as shown in Fig. 49. This is the ideal perfection of the optician's art. An ordinary uncorrected lens will always suffer from what is called spherical aberration, by which is meant the marginal rays come to a focus in a point on the axis

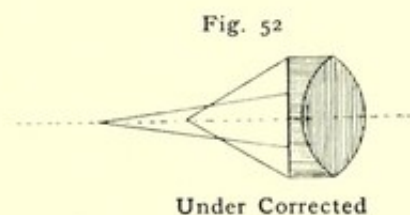
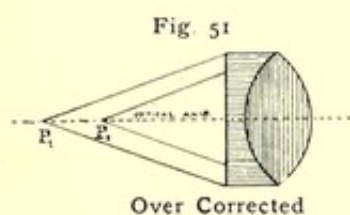
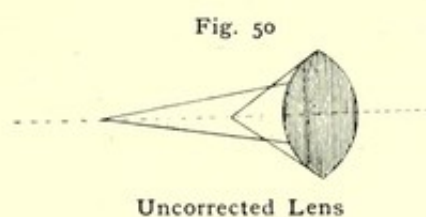
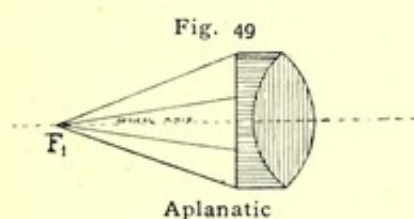

closer to the lens than those situated nearer to its axis or centre, as seen exaggerated in Fig. 50. The art referred to of the optician is to try and unite these planes of focus by combining glasses having different properties. If he overdoes it, producing what is technically called "over-correction," he brings the peripheral rays too far along the axis, as shown in Fig 51, and if he does not correct enough—"under correction" as it is termed—he leaves the combination with the same error outstanding, although to a less degree, as that possessed by an uncorrected lens, as shown (greatly exaggerated) in Fig. 52.

Now in a condenser it is evident spherical aberration should be as perfectly corrected as possible, and the ideal form should transmit a cone of rays of uniform light equal to its full aperture. In other words, its spherical aberration should be *nil*. Few condensers indeed will approximately do this. Even those by Zeiss are greatly faulty in this respect, but the last dry apochromatic by Powell and Lealand is a decided advance. The best series we have ever seen, we feel bound to admit, are

those recently introduced by Mr. Conrady, to whom reference has already been made.* Whether this be due to the same thought in their construction, (see page 78), which he holds to so strongly in the manufacture of his lenses already mentioned, it is difficult to say; but anyhow they transmit a solid aplanatic cone of great purity, nearly—if not exactly—of the same diameter as their aperture, and how this can best be ascertained and proved must be the next subject.

Let us consider the following. It is desired to ascertain the size of the largest aplanatic cone of a given condenser, whose N. A., we will say, is stated to be 1.0. Fix it in the usual position on the substage, and place on the nose-piece of the microscope first an objective of N. A. .6, and on the stage a diatom. Focus it with the objective, using as an illuminant the edge of the flame, and rack the condenser up and down until this image of the flame is seen across the field with the diatom lying in its centre. This is obtaining what is technically called *critical light*, and the resulting image is called "*The critical image.*" Shift the diatom just out of the field of view, still leaving a portion of the slip and its cover-glass *in situ*. Remove now the eye-piece, and look down the tube of the microscope. One ought to see the back lens of the objective full of light, because the aplanatic cone of the condenser should be greater than that of an objective 0.6, such as we are supposed to be here using. Return now the eye-piece and remove the objective, substituting one of 0.95 N. A.; again focus the diatom, and again obtain critical light by focussing the condenser on the diatom until the edge of the flame is seen across the field. Once more shift the diatom out of the field, and look down the tube as before. The back lens should be quite evenly filled if the aplanatic cone equals the numerical aperture. Then close the iris diaphragm until its edge is just seen, and carefully note the exact size of the opening with a pair of compasses. Now remove the 0.95 and place in its stead an objective of 1.40 N. A. Treat as before, with respect to focussing and obtaining critical light, and look down the draw tube. Only the centre two-thirds of the back lens is now seen full of light, and the slightest touch of the condenser upwards so as to try and

* Whilst these pages are passing through the press, our attention has been called to two somewhat new substage condensers, one made by Messrs. Watson and Son, the other by R. and J. Beck, of Cornhill. That by Watson is called the Parachromatic Substage Condenser. We find its N. A. is 1.0, and that its aplanatic cone exceeds .90 by actual experiment. Its focus is $\frac{2}{3}$ inch when used for high powers. Besides this it is so constructed that the top lens is removable, which lowers the power to about $\frac{1}{10}$ inch, when it can be employed for objectives of lower angle. We cannot adequately express our satisfaction with the performance of this piece of apparatus; it appears to be well corrected, and we think it has a great future before it, and we feel bound to offer the manufacturers our heartiest congratulations at being able to make as perfect an article at so low a price. It is so nearly *apo*-chromatic that it is not a little doubtful if it had been so-called we could have detected it to be otherwise. Its mount is also exceedingly neat, small, and well made, and it has a large working distance, and when used as an objective defines most admirably.

The arrangement by Beck has justly earned considerable repute. We tested it some little time ago, and found it proved a very admirable piece of work.

fill the lens to a greater amount will cause two dots of black to appear on each side of the lamp flame, which then becomes immediately recognisable. The last point before the appearance of these black dots (really due to spherical aberration) indicates the largest aplanatic cone of the condenser. Slowly and cautiously close the iris diaphragm until it is just visible and measure the size of the aperture with compasses as before. If the diameter is slightly greater than the previous measure for the 0.95 lens, the aplanatic cone is, of course, just above 0.95. A little experience and thought will soon render these operations quite easy, and the microscopist will be able to readily compare the largest aplanatic cone of the condenser he is testing with its advertised N. A., and the performance of one condenser with another.

The difference which so often exists in these two measures is very striking, and is said to be mostly due to errors in spherical aberration, most condensers being more or less under-corrected Fig. 52, and consequently focus their *central* rays at a greater distance than their *peripheral* ones. If a condenser be well corrected the lamp-flame image, as seen on looking down the microscope with the eye-piece *in situ*, should be, when accurately focussed, intensely bright, whilst the field is commensurately dark; but very frequently this darkness is conspicuous by its absence.

It may be here asked what does it matter even if the condenser should be badly corrected and possess a small aplanatic cone? It is this. The object of a condenser is to bring as much of the light of the illuminant as possible to a focus on the object. If now all the rays do not come to the same focus, all of those which come to another are so much lost, and only serve to scatter light into the field, and besides this, when using a broad illuminant (such as is produced after obtaining critical light with the edge of the flame, by turning the lamp-flame broad side on), not only is there an unequal illumination of the field which is immediately apparent, but no critical light is obtainable at the margins of the field without losing it in the centre, and *vice versa*. As now the best of definition will only lie over the area where critical light exists, so a critical image cannot be obtained over the *whole field at one and the same time*, and appearances may thus be produced in that part where it is absent which do not in reality exist. Again, in using oblique light, the loss at the margins of field is a serious matter. Two small pictures are shown in Figs. 3 and 4, Plate III., one giving the effect of the condenser out of focus over the whole field, and the other with true critical light. When we come to the photography of bacteria and diatoms, and other minute objects, it will be seen that neglecting to obtain this actual critical light over the whole field may be a source of positive evil. Compare Figs. 2 and 5, Plate III.

4. The definition given by a condenser is important so far as it goes in one respect

only. If a good sound image of the flame edge is not well shown, it is very obvious it is more difficult to obtain *critical light* with the same completeness as if it were good; but condensers must never be expected to give so fine images as objectives, it would make them too costly. To *test* for definition the condenser may be placed on the microscope, and its performance compared with that of an objective of the same N. A., always remembering that the slide should be turned round the opposite way, *i.e.*, with the cover-glass *towards* the mirror and the plane glass of the slip *towards* the condenser when fixed on the nose-piece. This, of course, is necessary because the correction has been made, or should have been made, by the optician with respect to

Fig. 53

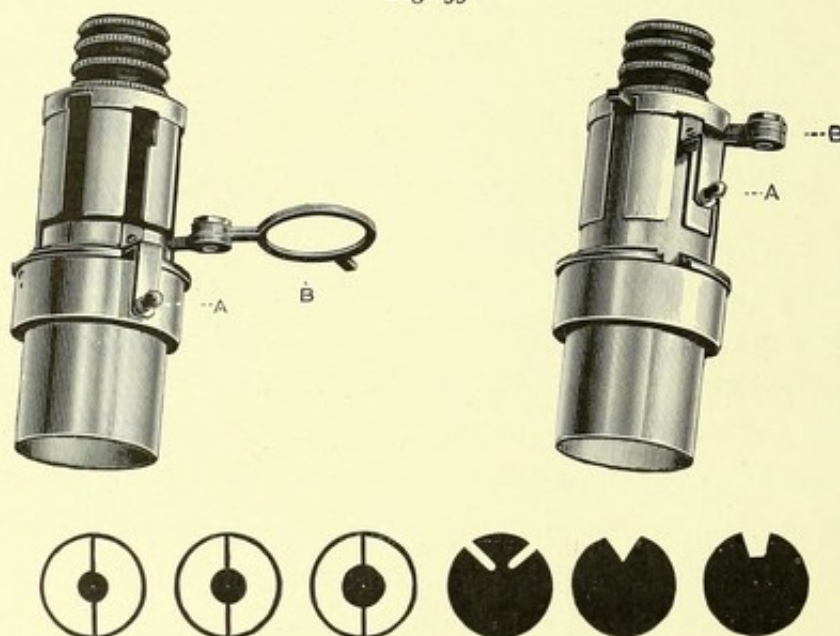

the thickness of the slip, just as he makes the correction for an objective with respect to the thickness of the cover-glass. Another point here comes before our notice: Slips, unfortunately, are of great difference in thickness, some being much thinner than others, just as cover-glasses vary, and it is with pleasure we note that Mr. Conrady has allowed for this variation within a certain limit in his new condenser of N.A. 0.95 by giving the mount what may be called *a correction collar*, much after the fashion that dry objectives of high power are made.

Condensers are manufactured, as before stated, of different N. A., and that of 1.0 is the highest that can be made dry, and all condensers of higher N. A. have to be oiled to the slip with cedar oil, just as the immersion objectives are oiled to the cover-glass. The reason of this is the same as that given in the previous article upon dry

and immersion lenses, viz., to make one homogeneous system so as to lose no rays, at least, not more than possible: hence immersion condensers give much more light.

We have only *tested* two high-angled immersion condensers: one, having a N. A. of about 1.35 by Conrady, is of exceptional merit; its aplanatic cone being almost, if we are afraid to say *absolutely*, as large as the N. A.; and the other by the old established firm of Powell and Lealand, which is close upon N. A. 1.40. This has a peculiar mount which admits of the use of several forms of diaphragms. It is said to be by Dr. Van Heurck of *exceptional* merit, and that we are not surprised to hear, for we have never heard of anything of an indifferent nature being sold by the firm in question. It is shown in Fig. 53.*

Somewhat recently Beck, of Cornhill, introduced a high angle condenser. We

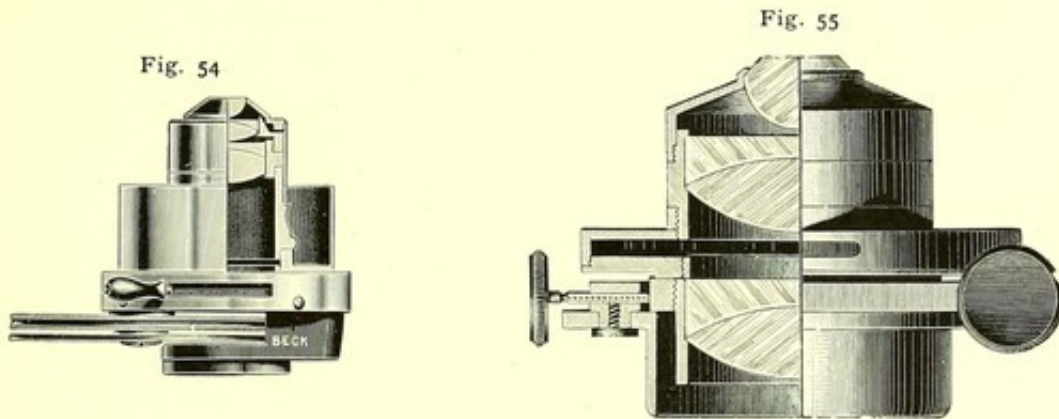

have no personal knowledge of this piece of apparatus, but understand from those qualified to judge that it meets with all the requirements of the microscopist. It is shown in Fig. 54 with an iris diaphragm attached. It is said to have a N. A. 1.3.

Lastly, in using all condensers, the distance of the lamp from the mirror, plus the distance of the mirror from the substage condenser, is important, and it would be well if makers marked this conspicuously on the mount. With some opticians it is greater than others, and can mostly only be found by direct experiment. Mr. Conrady has fixed a total distance of six inches, which we regard as a subject of great regret, as it seems too small.

All condensers should be mounted so that they can be *centred with the optical axis of the microscope* to enable them to perform at their best. This is very important, especially with those which are badly corrected for spherical aberration, thus forming

* It should be mentioned that this condenser is not *apochromatic* as Dr. Van Heurck accidentally reports it to be: the firm distinctly deny this and much wish it to be known, as it occasionally leads to misunderstanding.

another objection to the use of those with small aplanatic cones—they are so *extremely sensitive to slight differences in centring*.

In most microscopes this centring arrangement is provided for in the substage itself, as before explained, but the firm of Zeiss (and, we believe, a few others), do not do so, for their achromatic condenser is fitted with a centring collar of its own, which with the optical portion of the condenser forms one mass, to be dropped into the substage itself. We show in Fig. 55 their arrangement. It is unnecessarily heavy and not optically devised so well as it might be, for whilst possessing a N. A. of $\cdot 98$, its aplanatic cone is only $\cdot 65$, far too small we think: an opinion shared by many others (see Carpenter on the Microscope, Edition 1891, page 263).

Underneath the condenser some arrangement always exists to reduce its aperture. This is done either by the use of the iris diaphragm (see D in Fig. 58), or by a metallic plate perforated by several holes of different sizes. This plate revolves so truly that the centre of each hole is in the axis of the microscope; so, too, with the iris diaphragm, for when that is shut down its aperture should be central in the same manner. Some microscopists prefer the wheel diaphragm, as it is called, and others the iris; both have their advantage and disadvantage. The objection to the use of the iris diaphragm is the fact that, in the older forms there was no means to show to what extent it had been closed, so that when using the specimen again the process of ascertaining what sized aperture gave the best results had to be repeated *de novo*; whereas, if the wheel diaphragm had been used the size of the hole giving the best definition could have been noted for future reference. In the Zeiss and other modern microscopes this is got over by graduating the arc through which the handle of the iris is made to turn. Underneath the diaphragm, or in some cases immediately above it, is usually some arrangement to carry coloured glasses; obliquely or otherwise cut diaphragms; and some suitable arrangement for obtaining annular light and dark ground illumination.* This latter usually consists of a ring of brass having three radii passing from the periphery to the centre, such centre being rigid and of any size desired. Seeing, however, that the size of this stop has to be varied with each lens that is used, it is very obvious a large number of these stop diaphragms must be employed by the microscopist, and inasmuch as they are rather expensive, it becomes troublesome. It was to get over this difficulty we designed the arrangement shown in Fig. 48 (page 95). Several sizes and several shapes are supplied with this little piece of apparatus, so that the microscopist can readily suit each lens as he thinks fit.

* So far as relates to the coloured glasses, personally we prefer the use of a strip held by a Bunsen holder *apart* and so having *no* connection with the microscope; because its removal does not shake the instrument. It is shown in Fig. 24b (page 54).

Before concluding what we have to say concerning the substage condenser, we must explain how we can place its optical axis coincident with that of the microscope. In other words how to place it in such a position that a line drawn through the axis of the eye-piece and objective shall be coincident with the axis of the microscope. The importance of so doing is very great, and when it is shown how to take a photograph it will be seen that this point must be very carefully looked to or the best of definition and illumination will be lost. This is quite an easy matter with low-power objectives, but requires care with the high-power ones.

Having focussed the object (so as to get the objective in its usual position) the iris diaphragm is closed to its smallest extent, and lowered with the condenser until its magnified image appears in the eye-piece. With the adjusting screws it is then centred. When using high powers such as an $\frac{1}{8}$ th and $\frac{1}{2}$ th, it is *safer* to centre *first* with a half-inch, because then the error in centring for the high objective will not be so great as to cause the minute aperture of the iris diaphragm to lie *out of the field*, which may easily be the case if the condenser happened to be much "out of centrality." The same performance is gone through afterwards with the high-power, but it should be remembered to *always use a low eye-piece* at first, because with a very high one the image becomes too magnified. A point to recollect on centring is *never to bring the iris and the condenser up*, it should, we believe, without exception be *always down*. If this mistake be made, the top glass of the condenser strikes against the specimen slip, and that against the front lens of the objective, perhaps cracking all three, besides breaking the cover-glass and ruining the specimen.

(ii) **Critical Light and the Critical Image.**—"Critical light" is a term used to imply that the image of the illuminant is focussed sharply on the specimen. We have referred to it before, but it remains yet to be spoken of in its entirety. For many years microscopical observers did not perceive the importance of the remark made by Brewster so long ago, "that the best performance of the objective cannot be obtained unless the condenser is focussed on the object." We now proceed to explain how this is to be done.

Having focussed the object with the objective in the ordinary manner the substage *condenser* is racked up or down until the image of the edge of the lamp-flame or the lime is seen lying across the field; as now the condenser and the objective are both focussed on the object, *critical light* is said to be obtained. There are those who strongly object to this critical "flame image," as it is sometimes called, and will lower their condenser just enough to avoid it, but if this be done with high powers the resulting gain in even illumination must only be obtained at the expense

of critical definition. When searching for objects with low powers, say, with an inch or half-inch, it may be at times more convenient to sacrifice the ideal image to obtain an evenly illuminated field; for when the correct position of the object is found, it is simple enough to re-obtain the critical image for purposes of study. If equal critical illumination, however, *is* required absolutely over the whole field when *visually* employing the microscope, it can be obtained, if the condenser is really aplanatic, by turning the wick of the lamp broadways after it has been focussed on the object; but if the condenser be not so aplanatic as could be desired, *or when taking a photograph*, a second condenser (the best we know being called a Nelson's "Compound Bull's-Eye") must be interposed between the light and the mirror of the microscope, which, when properly placed, will have the desired effect.

As before stated, "critical light" should always be employed *if the objective is to perform at its best*. There are optical reasons, too recondite to relate here, which necessitate it absolutely and positively, and those who think differently must give satisfactory evidence that they have carefully read the writings of Nelson and other great authorities before any attention can be given to their theories. When "critical light" is employed the resulting image is called "critical" also.

(iii) **The Auxiliary Condenser.**—This usually consists of two lenses loosely fitting into a ring of brass and supported by a stand which is supplied with a centring attachment contained in itself as shown in Fig. 56 by Watson.

Personally we prefer having the lenses mounted like the limelight (Fig. 3, page 4) used by us, which has already been fully described, page 5. The arrangement is shown in Fig. 57, where the milled heads for raising and lowering are seen. An "iris" cap is also displayed, which fits over the lenses and reduces their aperture to a point of light when required.

The best position for this auxiliary condenser is such that it will throw *parallel* rays on the mirror, or if the mirror has been removed, on to the substage condenser. This is obtained by pushing it quite near the illuminant—the round side towards the light—so that the rays issuing from it are practically the same width at a distance of a few feet. A puff of smoke from some brown paper "half alight" will make their path very apparent and show them up admirably. If they widen, the condenser is too near the illuminant; if they come to a focus, too far away.

In some cases of high magnification we have found definition suffer decidedly from the use of this second condenser, whilst with other objects it was exactly the reverse! There are those better versed in mathematical optics than ourselves who declare that the final definition *must* always suffer unless this condenser *be corrected just as well as*

any other part of the optical apparatus, and that the occasions in which we have found benefit were in reality due to the fact that the parallelism of the rays falling on the substage condenser suited the specimen better than convergent ones.

To centre this condenser, remove the objective and eyepiece and place its iris diaphragm well closed to a pin hole, over the lenses. The tiny sparkling point can easily now be made central with the centre of the microscope tube. To complete

Fig. 56



Fig. 57

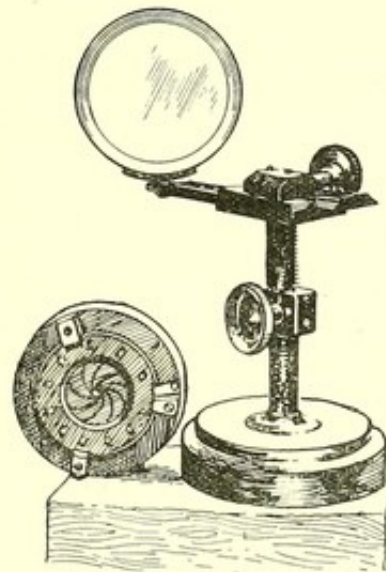

the adjustment, return objective and eyepiece and move the milled heads until the light is equally distributed over the field of view.

(iv) How monochromatic light *is obtained* is given in Chapter VI., Section I. (i), paragraph 8 (page 113), so that need not be entered into here, but its *use* has yet to be explained.

Monochromatic light is of two kinds :

- (i) **Partial**, obtained by the use of glasses of different colour.
- (ii) **Complete**, by the use of prisms, or by troughs filled with special fluids.

(i) **Partial monochromatic light** is used for two purposes :

- A. To increase contrast, and
- B. To reduce it.

(A.) To *increase* the contrast between *different coloured* objects in a specimen, partial monochromatic light is a great power in the hands of the photo-micrographer. This is especially felt when dealing with bacteria, which are usually stained one colour whilst other objects around, or the ground-work of the slide may be stained, another. For example, the bacillus of consumption stains red, and the remainder of the sputum in which it is found usually appears blue. If, now, a photograph be obtained in the ordinary way, a poor, flat picture results, in which the bacillus, the central object of attention, is only faintly seen. Visually, the slide may present plenty of contrast, photographically, it does not. The photographer, in this case, would use a coloured glass, either orange or green, the *depth* of the colour depending upon the requirements of the specimen. The effect of so doing is this: The orange or green glass cuts off the red rays and makes them jet black, and as black does not *affect the plate*, so the silver is not precipitated, and after development clear glass is left in the place of any deposit. This clear glass in the negative causes the print to become *black* which increases the contrast as required. It is necessary, as the illumination is green, that an isochromatic plate be used, and it is needless to state that the exposure has to be increased—say about three times that of white light—because of the illumination being by one colour only instead of by ordinary white light. This matter is dealt with in its entirety when speaking of the photography of bacteria later on.

(B.) To *reduce* contrast, partial monochromatic light may sometimes be employed. Suppose, for instance, a specimen where red blood-vessels are prominent, and one that contains details in the background desirable to be photographed. If an exposure be given for them, the rest of the specimen, which it may also be desirable to show, will be too faint. Yet, on the other hand, if a sufficient exposure be given for the latter, the details on the blood-vessels will be choked up by over-exposure and lost. If now, a red glass be used, provided a red plate be employed, and sufficient exposure added, the extra exposure will increase the detail where it is wanted, and yet not so much affect the portions where it is not required. A flat negative is now obtained, but one full of detail and having no severe contrast. See also p. 113.

(ii) **Complete monochromatic light** can only be obtained by the use of prisms as explained Chapter VI. **Section I.**; but objections are shown in the same place to this method. Troughs of coloured fluid may be substituted between the condenser and the illuminant, and these are effectual although still not quite so pure as when light of one colour is prismatically obtained. But it is to the *use* that we refer in this place. Space will not allow to explain *why* it is that the shorter the wave length—that is, the nearer the approach of colour to the violet end of the

spectrum—the better the resolution by the objective; but it is nevertheless quite true. Hence, microscopists have often desired some form of violet light to increase the resolution of difficult objects. But the difficulty is this: if the fluid be sufficiently dense to give pure violet light, the specimen is so feebly illuminated as to be hardly visible, not enough, indeed, to enable the operator to form with sufficient accuracy to produce a good picture even with a prolonged exposure. Electric arc-light answers better than lime-light, as it contains more violet ray, but sunlight is best. Both of these, it has been explained, are difficult to use (see p. 11); notwithstanding this such specimens as *amphipleura pellucida*, when it is required to show the lines really well as dots, demand its use, and with its aid Dr. Van Heurck has produced photographs which are the admiration of all photo-micrographers. We have found green light exceeding useful.

(v) When using the mixed jet the heat from the lime-light is so intense that the microscope becomes too hot, and the safety of the substage condenser, and most likely that of the slide are imperilled. To obviate this, we often place a shield of brass between the illuminant and the microscope, leaving but a small hole in its centre of sufficient size to transmit enough light to fill the substage condenser. Its position is shown in Figs. 24a, or c, page 54. This is only sufficient to prevent the heat striking the microscope *stand* itself, it is true, but, nevertheless, is of a great value if the exposure be a short one. Should, however, the operator have a very precious slide, or fear his exposure may have to be several times repeated, it is better to use a water-bath (Fig. 24b, page 54). It should be large, and filled with glycerine and cold boiled water. Some authorities recommend the addition of alum, but we have found *no* advantage by so doing. Should the reader be one who is more or less of a beginner, we should recommend him the use of the bath *always*, whether the auxiliary condenser be used or not. It is placed in our apparatus on the stand which holds the screen—shown Fig. 24b, page 54.

(vi) **The Exposure Shutter.**—There are many arrangements for this purpose. Some prefer a simple black card placed in any suitable position to intercept the light, others prefer some form, like a Thornton-Pickard, which is placed (actuated from without by a pneumatic release) *inside* the camera. Ourselves, we use a strip of zinc on a foot. It can be raised or lowered at will, and can be entirely removed from the table when necessary. It is shown in Figs. 24a, and b, page 54, where it is temporarily fixed half-way up, to make it show better. It is merely a movable horizontal arm, working on a pillar supported by an iron foot. With high powers it is placed between the substage condenser and the coloured glass or water-trough; but with

very low ones between the objective and the slip, as too much stray light passes into the apparatus if used in the former position.

The great objection to the shutter inside the camera is that it often shakes it during the release, which of course spoils the negative. But we are aware, in saying this, that some new forms of shutter are now made—since, indeed, we tried the plan—which are reputed to give no shake at all, in which case, of course, our objection falls to the ground. The best we have heard of although we have not had personal experience in its use, is that sold by Watson & Sons, and called by them their “inside shutter.”

CHAPTER VI

MEDIUM-POWER PHOTO-MICROGRAPHY

THE term **medium power photo-micrography** is usually restricted to magnifications extending to about five or six hundred diameters, where it is necessary only to use an inch or a half-inch objective, and in some cases a sixth. **Critical work** is said to commence where **medium** leaves off, and is so called because all adjustments, centring and focussing, are of the highest order possible. For this purpose too the highest N.A. is always necessary such as is obtained by the use of an $\frac{1}{8}$ or $\frac{1}{1\frac{1}{2}}$ th. The use of a sixth objective may be said to lie on the border land between these two divisions, but for convenience of description will be spoken of under critical or high-power work.

In this chapter, **Section I**, treats of the following :—

- (i) The different methods of illuminating an object placed on the microscope.
- (ii) To explain how to ascertain the amount of magnification given to any specimen photographed.
- (iii) To give details of an arrangement to exclude all extraneous light entering the camera at its point of juncture with the microscope.
- (iv) How the microscope may be firmly fixed on to the baseboard of the apparatus.

Section II. is devoted to explaining the actual method of taking the photograph.

- (i) By ordinary transmitted or direct light, using an inch and a half objective, with remarks upon the special development which may be required, thinning and intensifying the negative ; and also some remarks concerning *different* arrangements of lenses, camera length and eye pieces for obtaining the *same* magnification.
- (ii.) By the other various forms of illumination—reflected light, oblique light, dark ground illumination, and the treatment of opaque objects, and with polarised light.

SECTION I.—(i) The different methods of illuminating an object placed on the microscope, of which there are nine varieties.

1. **Direct Light.**—This is the usual form when photographing; where the mirror is removed and the microscope illuminated immediately by the illuminant, whether with or without the auxiliary condenser, Fig. 24A. page 54. In employing this form, the jet being lighted, the objective and eye-piece *in situ*, the object is focussed. The substage condenser is then centred by means of its adjusting screws in a manner already explained page 103, and the auxiliary condenser, if employed, and the limelight are also placed central with the axis of the microscope in the manner described on page 105 as shown in Fig. 24b. page 54 until the field is equally illuminated.

This may be no easy matter. If the lime be placed too near the jet, it burns away with such rapidity that small pieces are apt to fly off, which makes the field brighter in some parts than others. If too far off, the area of the illuminant is too large, and with *very* high power work, definition may possibly suffer. Direct experiment will soon teach the operator the best position of the lime: we usually find for most work, with the jet by Beard, it is about one-eighth of an inch from the mouth of jet. "Centring of the lime" as it is called, is made in our arrangement most easily and effectually by the two screws in the stand already described page 5. It is usually done *before* screwing up the auxiliary condenser in its place. This effected, the auxiliary condenser and bath are brought into position, and finality of position with respect to the former is obtained by shifting it like the lime on its stand until the field is equally illuminated. The rays should issue parallel from this lens, and to obtain such the point of illumination on the lime should be exactly in the focus of the condenser. To find this it is only needed, as before said, to blow a little tobacco smoke, or burn a little piece of brown paper, in the path of the rays which immediately shows their direction. If they *diverge* the lime is too *near* the lenses, if they *converge* the opposite condition is the cause. With some specimens a little convergence improves definition, with others the reverse obtains.

2. **Reflected Light** is only used when the upright apparatus is employed. The *flat* side of the mirror is usually used for high powers, but for the inch and half-inch, and occasionally the sixth, and rarely the eighth and twelfth the curved side is preferable. The mirror should be well silvered and be as *thin* as possible to avoid duplicity of image.

3. **Oblique Light.**—In this form of illumination, the light is made to impinge quite obliquely on the condenser and so on the object. It is very obvious then, that

the larger the aperture of the substage condenser, the greater the obliquity that can be obtained. To assist in cutting off extraneous light, a diaphragm is placed beneath the condenser, between it and the light, having a segmental, crescent, or other-shaped form. Reference has already been made on page 94 to the caution to be exercised in using this form of illumination. It is obtained in some microscopes by reflecting the light obliquely from the mirror, which is itself shifted by the operator quite on one side of the optical axis. In the continental form of stand,

Fig. 58

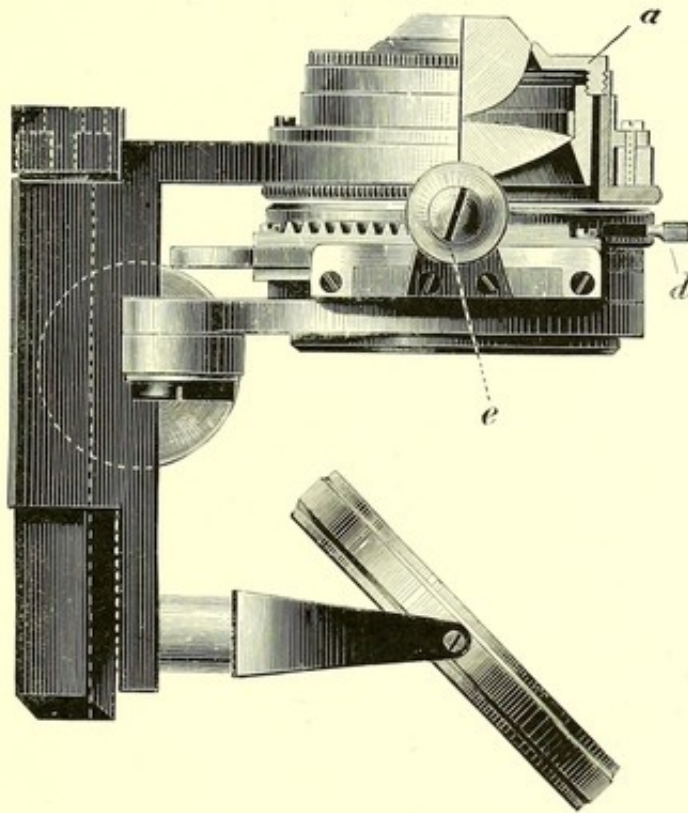

where the mirror will not move laterally, but only in all directions *about* the axis of the microscope, a special arrangement is devised which is shown in Fig. 58, where it is seen that a small handle *e* moves the entire mechanism containing the iris (or other super-imposed specially formed diaphragm) *out of the axis of the microscope*. All that the microscopist has to do then, to obtain oblique light of any extent is simply to turn this handle. But seeing that this movement would only give oblique light in *one* azimuth, which would be most inconvenient, the difficulty is met by making the whole mechanism up to *d* (the iris diaphragm) *revolve completely around the axis of the microscope*, which thus enables the operator to obtain oblique light

in *any* azimuth he may desire. It is an exceedingly ingenious arrangement and one that answers admirably.

When the use of the oblique light is finished with, the centrality of the iris diaphragm with the axis of the microscope, is known to be re-obtained by turning the same handle backwards until a distinct click is heard, such click gently restraining all further movement and audibly indicating the return of the parts to their original centrality.

Oblique light must not be confused with what has been called "double oblique light" for they are quite different, as pointed out later on page 113.

4. **Annular Light.**—This has been already referred to on p. 94, and is obtained by stopping out the centre of the condenser; and is the same practically only to a different degree as dark-ground illumination when produced by a "spot lens."*

5. **Dark Ground Illumination** is said to be obtained when the object which is mounted *transparently*, is supplied with a *dark ground optically produced*, although itself remaining brilliantly illuminated. The effect produced by this means with low-powers is at times exceedingly fine. It may be obtained by (1) the "spot lens" as just described, and on p. 102, the Davis diaphragm being closed a little to complete the effect; (2) by use of the stop placed beneath the condenser which may be made of different sizes to suit the lens used, or the special form designed by ourselves, p. 95, Fig. 48, and (3), by the use of an arrangement called the Paraboloid. This consists practically of another form of condenser which is fitted into the substage in the place of the ordinary condenser, having a black central disc of brass capable of being pushed up and down independently of any movement of the condenser itself. Considerable experience is necessary to thoroughly master this ingenious arrangement designed by Mr. Wenham. Having obtained a good illumination of the object the black metal disc is pushed up or pulled down and the Davis diaphragm closed until the black background is obtained. In photographing this effect it is not well to obtain the field as black as when the arrangement is used for visual purposes; especially when a lantern slide is desired to be shown on the screen. The effect is spoilt if the back-ground is too completely black. This is not so, however, in a print, or when visually using the microscope. It may here be mentioned lantern-plates do not give usually such good results as an Edward isochromatic negative plate. About one second exposure required or perhaps less at 1 foot from a gas-burner. An example is given Fig. 5, Plate V.

* Condensers are sold which admit of a piece of black paper being affixed to the lens nearest the light—hence the name "spot lens."

6. **The Illumination of Opaque Objects.**—It is obvious transmitted light will be of no service as the object is mounted opaquely. To illuminate this type of slide it is often necessary to remove the cover-glass, for the reflections caused by it, although not so noticeable *visually*, are very detrimental *photographically*. With the limelight it is necessary to use a condenser, the auxiliary does very well, and with them a bath to prevent the slide being melted with the heat. Many objects require *two* limelights, one on each side, each being provided with condenser and water-bath. This form of illumination is sometimes called "double oblique light." It has nothing to do with "oblique light" previously mentioned on page 110, which has already been pointed out. The great difficulty in illuminating opaque objects is to prevent the objective casting a shadow on them. With high-powers as they have to be so close, this is almost impossible to avoid, and for that purpose Zeiss has brought out a special form of illumination, Fig. 63, page 113, consisting of a prism placed above the objective which is illuminated from the side. The light passes through the prism and the objective and thence on to the object and back again through the objective to the eye lens. *This* arrangement has not answered our expectations any more than a large reflector we had made—Lieberkubn fashion—to throw the light by reflection on to the object. An illustration of the photography of an opaque object is shown in Fig. 6, Plate V., and of "double oblique illumination" in Fig. 4, Plate II. It was a particularly difficult object as the hairs stood up quite a sensible distance and to obtain depth of focus sufficient for the general effect was no easy matter.

7. **Illumination by a Large Cone, Small Cone and Hollow Cone** have been explained on p. 92.

8. **Monochromatic Light, Partial and Complete.** **Partial** monochromatic light is obtained by the use of coloured glasses interposed between the illuminant and the substage condenser, or between the condenser and the object. In the blocks of our apparatus, Figs. 24A, B and C, page 54, the Bünsen holder is seen holding a strip of glass.

Monochromatic Light completely so called cannot be obtained by the use of any glass we know of. It would be a great convenience if it could. This can only be procured by the use of a prism of dense glass to break up white light into its component colours. This method gives colours of great purity and definite wave length, but is difficult to arrange, because the beam is too narrow to anything like fill the field of the microscope, and cannot in some cases be made to do so even with the auxiliary condenser. For that reason a more powerful set of prisms has to be employed, giving greater dispersion, but the illumination then is so feeble that, unless

sunlight or electric light be used, the specimen cannot be seen with sufficient clearness to be properly focussed.

The next best arrangement to obtain monochromatic light is by the use of a trough made entirely of glass, the vessel having parallel sides, and being filled with solutions of certain strength and different substances, according to the result required. These are held *in situ* by the Bünsen holder. Zeiss makes excellent troughs for this purpose, but they are very expensive. English firms now supply them cheaper and we do not know they are in any way inferior. Further reference will be made to these matters when dealing with specimens requiring either complete or partial one-coloured light.

9. **Polarised Light.**—It is not the place here to discuss or explain what is meant by the polarisation of light interesting as it undoubtedly is, and so it will only be spoken of so far as the subject affects the photo-micrographer.

It is obtained for his purpose by the use of two Nicol's prisms which are named after their inventor. One is placed beneath the object in the substage, and is either capable of revolving on its axis by its own special arrangement, or being fixed into the body of the substage, is made to revolve by a special construction to be found ready made in that part of the microscope itself as built by several makers. Anyhow (and no matter by what means) it must be capable of revolution about its axis. The second Nicol is placed either in the body of the tube—the most common place—just above the objective; or is mounted with lenses as an eye-piece and placed at the eye end of the tube instead of the ordinary ocular.* Revolution of either about its axis produces the effect as seen down the microscope of intermitting waxing and waning of light. To produce the well known and beautiful variations of colour a film of selenite or of mica is interposed between these prisms. Revolution then causes marvellous changes of colour. If now suitably prepared objects are placed on the stage, examples of colour rendering are exhibited on rotating one or either prism too beautiful to describe. With some specimens it is not needful to use the mica or selenite for they themselves are able to produce excellent differentiation in colour or in varying phenomena in black and white. Both of these the operator can photograph. The actual taking of the negative is no more difficult than any other. All sorts of contrivances are made for placing different thicknesses of selenite or of mica in the field but for a description of these the reader is necessarily referred to books on the microscope.

(ii) **How to ascertain how much an object is magnified.**—It must be

* Owing to the material (Iceland spar) being so scarce, Zeiss now sells a prism smaller in size, after Prazmowski which fits over an ordinary eyepiece.

now explained how the photographer can ascertain how much magnification an object has received at his hands. The explanation is given here as perhaps the most suitable place, but it must be understood the remarks that follow equally well obtain with high power or critical photo-micrography.

The reader must frequently have read, or heard it said, that an object is "magnified so many diameters," and we must all have heard also of a microscope being able to magnify so many "hundreds of times." To explain the difference implied by these two terms, consider Fig. 59.

An enlarged image of the object A B C D, we will say is cast upon a receiving screen at a given distance, and shown as E F G H. If, now, a pair of compasses be taken, it will be seen that E G is twice A B, G H twice B C, F H twice D C, and E F twice A D. It is not difficult to understand the dotted lines, L K M and O K P are drawn equally dividing E G and F H, and E F and G H respectively.

Fig. 59

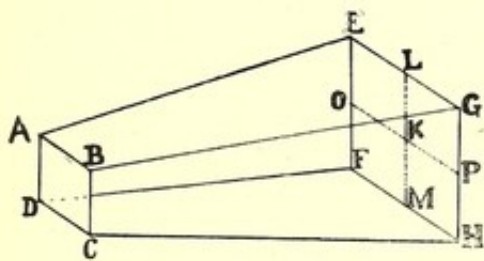
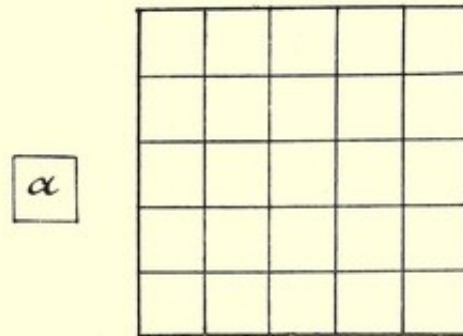

Fig. 60



Then E L and L G each equal A B, G P and P H each equal B C; and so on with the other sides. A little more attention and it is evident that there are four squares, each equalling A B C D; so this object is said to be magnified four areas or four "times." But it is equally obvious that A B C D is only magnified twice in each direction—twice from above downwards, and twice from side to side. Hence, when speaking in what is termed linear measure, the object is said to be magnified two "diameters." This holds good for any magnification. Consider, for example, Fig. 60. Here the little square A is magnified five *diameters* in the amplified picture by its side, but this large picture has twenty-five little squares in it, so it is said to be twenty-five *times* as large.

For reasons which need not here be discussed, scientists always speak in linear measurement, employing the term "diameters" in preference to using terms of

superficial valuation, such as so many "areas" or so many "times." Objectives, then, as well as eye-pieces, are said *to magnify in terms of diameters* and *not* in "areas."

We now pass on to describe how to ascertain the amount of diameters an object is magnified when seen in the microscope or when photographed on the plate.

If we use apochromats this is a very simple matter, for each objective is of an accurate focus, and so the initial magnifying power is easily known, and so, too, with each compensating eye-piece. Here follows a list of the amounts universally adopted for the standard magnifying power of objectives of different foci. It will be convenient for future reference ;—

| A lens of 1 inch or 24 mm. focus magnifies | | 10·5 diameters. | |
|--|------------------|-----------------|-------------|
| " | $\frac{2}{3}$ " | 16 | " " 15·5 " |
| " | $\frac{1}{2}$ " | 12 | " " 21·0 " |
| " | $\frac{1}{3}$ " | 8 | " " 31·0 " |
| " | $\frac{1}{4}$ " | 6 | " " 42·0 " |
| " | $\frac{1}{6}$ " | 4 | " " 63·0 " |
| " | $\frac{1}{8}$ " | 3 | " " 83·0 " |
| " | $\frac{1}{12}$ " | 2 | " " 125·0 " |

What this really means is that if any lens of exactly an inch focus is placed on the microscope and a piece of ground glass held at a distance from it of 10 inches, the magnification of the object is 10·5 diameters.

Now to calculate the final amount of the amplification of the image as seen in the microscope *when the eye-piece is added*, it is only necessary to multiply the initial power of the lens by the initial power engraved on the eye-piece, and the result is the total amount of the magnification as seen by the normal eye when looking through the instrument. This, then, is the simple rule for visual purposes when using apochromats. But when we come to photo-micrography, where the image is projected on to the plate or the ground glass, another factor comes into play—it is the length of the camera extension employed. If the ground glass be placed at ten inches from the eye-piece it will be found, although the object is seen reversed, the resulting magnification is exactly similar to what is visually seen on looking down the instrument, and so equals the initial magnification of the objective multiplied by that of the eye-piece. But when the length of the camera extension is increased the amplification is then directly in accordance with the amount of the camera stretch beyond this ten inches. For example, if we place an object on the stage and use the inch objective with a six eye-piece we should find the object would be magnified 63

diameters on the ground glass held at 10 inches from the eye-piece; but if now it be removed to 20, inasmuch as 20 divided by 10 gives a quotient of 2 our 63 diameters' magnification would become 126. Similarly, if we drew out our camera 30 inches, as 30 divided by 10 gives a quotient of 3, our object would now be magnified 189 diameters. It is seen, therefore, to be a very simple matter to judge the amount of magnification an object has received when using the perfected system of the apochromatic series of lenses. This, be it understood, is not due to apochromatism considered as such, but because all objectives are *really* of the focus stated. But when employing achromatics, which are not so perfect in their focal lengths, both as respects the objective as well as the eye-piece, another method has to be employed.

Place any power—say an achromatic one inch, which very likely is really a two-thirds inch—on the microscope, and use first what is called an "A" eye-piece. Having procured a stage "micrometer" (which is only another name for a cover-glass ruled with lines by a diamond a definite distance apart and fixed on an ordinary 3×1 slip), and having focussed any two of the lines which are separated by an interval thought to be of convenient size, the ground glass is placed at a distance of 10 inches from the eye-piece. We then take a pair of compasses and measure directly the interval of these lines apart, and divide it by the distance which we know exists between the two lines on the micrometer. It is very obvious that the quotient thus obtained is the linear magnification produced by the lenses—the objective and the eye-piece—as they then stand. It is the same, in point of fact, as would be seen by the normal eye looking down the instrument through the eye-piece save that it is reversed in position.

This process is repeated with each eye-piece, and with each objective in succession. It is now very evident that we can apply the figures thus obtained, whenever we use a similar combination of objective and eye-piece, always recollecting that the figures only apply to the camera length of ten inches. If this be increased the magnification is augmented in just the same way, and just the same manner as already explained when employing apochromatics. The photographer should do these computations for his photographically corrected achromatic objectives and his eye-pieces with the greatest of care, as when once done—provided the tube-length of the microscope is kept the same, and the camera length does not exceed ten inches—the results will be always correct.*

* The direct measurement of minute quantities such as the number of lines to the inch in exceedingly small diatoms, like those in *amphipleura pellucida*, is not given here as it was thought to be out of place, but for the assistance of those interested in the subject, it is fully described in the Appendix.

(iii) **How to exclude light from junction of camera and microscope.**—It will be seen on reference to Figs. 24A and B on page 54, that it is evident some sort of arrangement must be contrived to keep the extraneous light from entering the point of union of the microscope tube—wherein is placed the eye-piece—and the camera. Several arrangements can be devised, one being to join up the gap by tying a bag of velvet on to the projecting end of the microscope, and securing it in turn to some suitable form of nozzle fixed on to the camera. We have given up this arrangement in favour of the following, Fig. 61, which is far more satisfactory. It keeps out all light and yet allows a limited amount of movement of the tube which is of course required when focussing the object. The dimensions are as follows;—That portion attached to the camera is $1\frac{1}{2}$ inch wide and $1\frac{1}{2}$ long. It is joined on to a flange, which fits on to the ordinary sliding front, whilst that fixed on to the draw-

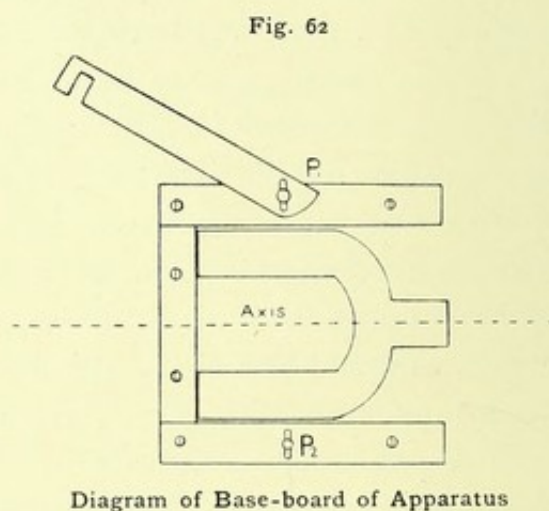
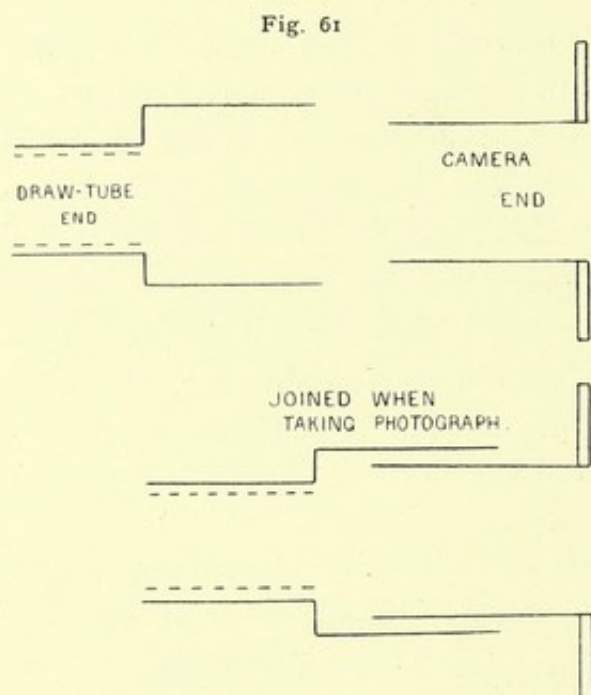

tube of the microscope is $1\frac{3}{4}$ inch in diameter at its free portion, into which the other passes, but reduced in diameter at its other extremity to fit the draw tube, allowance being made for a cork lining to prevent it scratching the lacquer.

(iv) **How to fix Microscope on Baseboard.**—Lastly the microscope must be fixed on to the apparatus *firmly*. In the expensive forms of apparatus this is fully provided for, and is shown in the diagrams already given: but in our own arrangement it is obtained by a special form of clamp, very simple, and easy to make. Three

pieces of wood are made about one-sixteenth of an inch thinner than the foot of the horseshoe stand of the microscope. They are fitted together and screwed into the large base-board of the apparatus, as shown in the accompanying diagram (Fig. 62). A fourth piece of wood (covered with velvet) is also shown there, which turns on a screw-down pin at P₁, a washer one-sixteenth inch thick being interposed between it and the piece beneath, and passing over the foot of the instrument, is held by the thumb-screw figured at P₂. The axis of the microscope should correspond to the axis of the camera. Swinging the arm round, it is locked at P₂, and the microscope thereby firmly fixed.

SECTION II.—TAKING THE PHOTOGRAPH

(i) **Taking the Photograph with ordinary Direct Light.**—We now proceed to show how to take a photograph with each low power, and to make the explanation more comprehensive and explicit, it is proposed to take a series of well-known "test objects" as types of the different objects which lend themselves to photo-micrography.

We commence with the proboscis of a blow-fly, or ordinary blue-bottle, one of the most common test objects for an inch with an A or B eye-piece if using achromats, or an inch with a low-power compensating eye-piece if we elect to employ apochromatics. Either of these eye-pieces will furnish us with two reasonably sized photographs of this interesting object when using a 10-inch camera, but if we desire to photograph the finer details of its structure it will be necessary to substitute a half-inch in place of the inch, because its N. A. being greater it will reveal more delicately the minutest details (see article on lenses, p. 77 *et seq.*). So, too, we may have to employ a sixth to show distinctly some of the finest hairs which exist on the membrane that stretches between the two lobes of the organ, and we shall consider each separately.

To commence with, it is necessary to centre the limelight, which means that the brightest point of the lime shall be brought into the centre of the field of view in the optical axis of the microscope. This is effected by the milled-headed screws, which raise or lower the light, or move it from side to side in a manner already described. This finished (with the microscope horizontal), the lowest power substage condenser (focus about half-inch, and N. A. .48) is placed in such a position as to give critical light (see p. 103). Shut now the iris diaphragm as closely as it will allow, and lower the condenser again until the minute aperture of the iris is seen with a low-power eye-piece and one-inch objective. Most probably the hole will not be central—if not, it

must be made so by using the adjusting screws. Re-open now the iris, and re-obtain critical light, and adjust the lime once again till its brightest part is seen in the centre of the field. The image of the lime becomes now very objectionable, and far too bright for the eye to stand, so it is best at this juncture to place a green glass between it and the condenser. Lowering a condenser practically reduces its working aperture, but seeing the aperture of the condenser in use is higher than that of the inch objective, we may lower it until the field is equally illuminated without fear of losing definition. Still, if we desire, for some special effect or reason, to use the absolute critical image, we must broaden out the narrow image by the use of the auxiliary lens, placing it in position as shown in the diagram, Fig. 24B page 54 (about two inches from the lime), moving the rack adjustment up and down and from side to side until the light is evenly distributed over the field. The substage iris may have to be reduced in aperture when using the inch objective or the object may suffer from what is called "flooding of light." It is not often that critical light is required to be used with so low a power, for the simple reason that an inch objective is mostly employed to give a general view of an object, the relation of the many parts to the whole, rather than the *details* of any particular portion. The principal occasion with an inch objective for requiring critical light is when photographing the general appearance of a minute object like a diatom, in which case the camera may have to be *specially* increased in length, even perhaps, to as much as six feet. Magnification, then, is the only object, for the N. A. of the inch is far too small to give much detail. Still, if it be desired to use the lens to the best advantage, critical light *must* be employed, and as the substage condenser will not spread out the light all over the entire field, the auxiliary condenser must be brought into use to do so effectually.

Having then centred the condenser and the lime, and broadened out the light if necessary, the green glass may be removed and the camera placed in its slides, as shown in the diagram, Figs. 24A and B, page 54, taking care that the piece of brass tubing on the camera, which slips loosely into that portion attached to the microscope, *does not touch it at any point of its circumference*. The camera is then drawn out to 10 inches or more as desired. It is firmly fixed to the table by the wooden screws. Then, if we are not using the auxiliary condenser, we ask the assistant to turn the lime just a touch from side to side or up or down till we feel assured there is equal illumination; and, if the auxiliary condenser is added, the same process must be repeated again by shifting it (by means of its two racks) until the light is equally illuminated over the whole field as before described.

Focussing is the next operation. When employing the inch, it is best done at first

with the coarse rack, being subsequently completed by the aid of the fine adjustment, which is turned (through the medium of the silk cord) by the brass handle shown in the diagram, running beside the camera. We then arrange the shutter so that it will drop a sufficient depth—such distance being regulated by the stop-screw—to cover the entire substage condenser. The light is then temporarily turned down by means of the “cut-off” handle described when explaining the jet, whilst two plates, if not sold as such, are being “backed” previous to placing them in the dark slide, which, it may be here stated, can be done at once, even if they are not quite dry. The light is then again turned up, and, having given one final glance at the ground glass to make us feel assured the light has remained equally distributed over the field, and that the focus is perfect, the exposure is made. It is best to note the exact time by a watch for this object, under the circumstances narrated about two or three seconds. Note in lowering or raising the exposure-shutter not to let it strike the microscope.

The second plate is then exposed in a similar manner, giving it double the time of the first, as by that means the operator is able to judge more accurately the correct exposure.

It is possible when these pictures are developed (about how to do this we shall shortly speak), that although they are sharp there is still a lack of contrast; each negative looks flat, whilst the object does not “stand out” in the way it should. This is probably due to the fact that too much light has been admitted to the objective—it has been what is called “flooded.” To obviate this we had better look at the object again and see if by shutting down the iris diaphragm a trifle we do not get a better contrasted effect. It must not be so closed as to produce diffractive phenomena—such as bright lines around the hairs, Fig. 3, Plate III.—for if so we obtain a photograph of optical phenomena, and not one of the proboscis of a blow-fly. If, however, we close our iris as much as we dare and yet are not satisfied with the picture on the ground glass, which experience will soon teach us to see at a glance, we must gently close the Davis’ diaphragm situated above the objective, just at the end of the microscopical tube. This must be used with much caution, for a very small amount of closing will produce a great effect upon the picture, and it will be entirely spoilt if closed too much. If the objective be a good one, and the eye-piece equally so, and all extraneous light excluded from the camera at its juncture with the microscope, our picture should be now one full of brilliancy and sparkle. Fig. 8, Plate III., and Fig. 4, Plate III.

Another good object somewhat similar is the leg of a bee; it is shown in Fig. 6, Plate III.

A specimen of the resulting photograph taken with a photo-achromatic by Wray is shown in Fig. 1, Plate III.

Development.—The general development of a negative has been already given, but to make it more explicit and to save the reader referring back, the process is again given below with certain *additions* which appertain to the development of *photo-micrographical* negatives which do not so much obtain with negatives of ordinary subjects.

It will be best for the beginner to develop each of his plates separately, for which purpose he takes 3 drachms of each solution, details of which have already been given, page 33, 3 drops of bromide solution, filling up to 8 drachms with water. This is the proportion in ordinary cool weather, but when operations are conducted in summer months, when the heat of the dark room is very pronounced, it will be very necessary for the developing solutions to have stood for some hours in cold water, and it will be better to use $2\frac{1}{2}$ drachms of each solution with 3 drops of bromide, filling up to the ounce with water. The gas light of the dark room should be screened by two layers of ruby fabric, and if the burner be a very bright one, an additional one of yellow. Having wiped the "backing" off the plate, easily done with a wet rag—which should be kept in one corner of the sink—the negative is placed in its developing dish with the sensitive surface upwards, and the 8 drachms of developer flooded over it in one sweep. Till experience is gained it will be frequently found that the plate is not immediately uniformly covered. The dish then should be violently shaken laterally to ensure such a condition, for, if not, a stain will be produced on the final negative, hopeless to remove. The cover to the dish should be at once placed over it and not raised for, say, half a minute, one ruby fabric being removed from the gas. About this time, if the exposure be correct—in cold weather it may be considerably longer—just a faint outline of "something" appearing on the emulsion should be seen. We do not say this will always be the case, but we mean that within half a minute to one and a half minutes there should be some difference shown in the portions of the negative that have been exposed to the light, in contradistinction to those where the light has not reached. The re-covered dish is then rocked steadily to and fro, until slowly and uniformly the image appears. Notice should now be taken as to whether the background appears uniform. If the details rush up with great rapidity, it is a sure sign of over-exposure, and 3, 6, 9, or 12, or even 24 drops of the bromide solution should be rapidly added accordingly. If, however, the strongly-lighted portions of the picture appear grey at first, gradually deepening in density, and the

whole picture comes out slowly, clearly, and uniformly, we may nearly always rest assured the exposure has been correct. On the other hand, if no picture comes for some minutes, and then exceedingly faintly, we may be equally certain the opposite condition of things obtains, and the exposure has been too short. Provided, first, that the exposure has been correct, we then continue rocking the developer over the negative, until the details, at first so bright and clear, fade into one common blackness over the whole plate. At this juncture it is raised from the dish and the back of the plate examined. We should expect to see the picture appearing there, not complete in detail, but an outlined effect. With correct exposure this effect is produced *slowly*, but with under-exposure *very rapidly*—an indication not to be overlooked. If, then, it comes slowly, we let it proceed by returning the plate to the dish, until, in point of fact, the picture can be moderately well seen on the *back* although *quite lost in blackness when looking at the front of the negative*. Those commencing *photo-micrography* make here the frequent mistake of removing the plate too soon; it wants much more development than an ordinary one. Presuming now the image is fairly well seen on the reverse side, the developer is poured off and the plate well washed under the tap. Washing completed, it is placed in the fixing solution, a bath composed of hyposulphite of soda and water. It is a convenient plan to obtain one of the large sweet jars used by pastrycooks, which are provided with a solid glass stopper surrounded with a band of cork, into which are placed the crystals of hyposulphite—commonly called “hypo”—to about one-third part of its depth, filling up to the brim with water. This is left for a few hours and forms a most convenient concentrated solution. Before taking a photograph the bottle is shaken, and two parts of the solution are added to one of water and put in the “fixing-bath dish.” Into this solution then we are supposed to have placed our developed and washed negative.

Whilst this is fixing let us go back to the consideration of the plate which, we will suppose, was over-exposed, lying in the developer to which we have added the extra bromide. It has been soaking, we will presume, all the while. The developer is rocked to and fro until we begin to find the back of the plate turning slightly grey, the front of it having long ago turned black. At this juncture development must be stopped and the negative washed, or it may become so dense that the gas flame cannot be seen through it when taken out of the “hypo.”

Great judgment is required to know how long to let the plate soak in this highly restrained developer, and it is not at all impossible the tyro will find his patience very severely taxed before learning how to save a plate having received too long an exposure, and it is an art to do this well in extreme cases. All negatives should

be left in the hypo some little time—say five minutes—after the last trace of yellowness has vanished.

Let us now examine our negative in front of a gas flame with a piece of ground glass interposed between the two—the flame and the negative. If the exposure and development have been correct the proboscis should be very clearly shown upon a black background, and if the focussing has been perfectly carried out, the little hairs protruding from the lobes of the organ should be quite plainly seen sharply defined; so, too, ought the edges of the suctorial tubes, as well as the small hairs when looked at through the focussing glass, applied, of course, to the back of the negative. It should be noted that as the proboscis itself is not absolutely flat it is impossible for the whole of the object to be absolutely in one and the same focus. Should, however, the negative appear choked, and the clear portions of glass between the rings of the suctorial tubes overcast with shadow—blotted out, in fact—and the background so pitch dark that the gas flame can scarcely be seen through it, we know that one of two things has taken place—either we have over-exposed our plate or else we have over-developed it—perhaps both. One other alternative may possibly be seen, a faint or perhaps a fairly defined image of the proboscis, visible upon a background *far too transparent*. This is a common fault and it occurs most frequently to those commencing. It produces a positive with a muddy background, superimposed upon which lies the image of the proboscis faintly and sickly defined. This arises from under-exposure, and nothing we know of will cure it save taking another picture.

Supposing we wish to save a picture which is overcast and evidently over-exposed or developed, we may do so in a great measure by allowing it to dry after washing a couple of hours in water, to rid it of its hypo, and then again placing it in water for a few minutes while we are preparing the thinning solution. Of these there are many, and each photographer may be said to have his pet formula; the one we prefer at this stage is that adopted by most photographers in the trade. It is simple enough to make, and efficacious to use, but, seeing it is desperately poisonous, must be handled with extreme care, and the operator must be provided with an india-rubber finger-stall for any finger with a hang-nail or open scratch. To make the solution one proceeds as follows: Place one or two pieces, about the size of a very small marble, of cyanide of potassium in about 1 oz. of water in a measure, and when dissolved or nearly so, add 20 or 30 drops of a very concentrated solution of iodine in spirits of wine. The brown solution of the iodine instantly disappears as it is added to the cyanide. The iodine solution must be very strong, at least three or four times that of the liq. iodi of the British pharmacopœia. Having stirred well with a

stirrer, the quarter-plate negative is placed in a half-plate dish, in which enough water has been added to just cover the plate. A fresh measure is then taken, the water out of the dish emptied into it, and about a teaspoonful of the cyanide cum iodi solution added. The newly mixed solution is then poured over the plate as it lies in the half-plate dish and the effect carefully watched. If too strong the thinning will proceed at an alarming rate, and the negative must be taken out and washed in water or it will be completely destroyed. It is therefore well to proceed with some caution, adding but little of the cyanide solution at first until the learner has acquired some experience. Directly it is lifted out, and before looked at, the plate should be rinsed very freely in water, for if not, streaks will be immediately formed where the fluid runs down the gelatin, which cannot possibly be removed. *This precaution should certainly not be forgotten.* After thorough rinsing hold it up to the light with the ground glass between it and the flame, and let the operator make up his mind whether he thinks it sufficiently thinned or not. If not, the process must be renewed; if sufficiently reduced return it to the sink, where it should have at least one or two hours' good washing, besides a gentle rubbing over the surface of the film as it lies *under water* with a piece of cotton wool. It is not a little curious that stains may arise which hopelessly spoil the final result at this stage if the washing be neglected, and therefore the operator is cautioned not to leave this portion of the treatment to chance.

If the photographer elects to thin the negative before the washing after fixing—that is to say, directly he has taken the plate out of the hypo bath—he may proceed as follows: The quarter-plate negative is placed in a half-plate dish and covered with water; this is returned to a measure, to which is added about a teaspoonful of the concentrated solution of hypo already mentioned and about a drachm of a solution of ferridcyanide of potassium (150 grains to 20 ounces of water). When mixed thoroughly this solution is flooded over the negative, taking care not to pour it all over one portion of the same, as by so doing it is possible that that portion so treated will be more thinned than the rest. After a few seconds the film will appear more transparent, and, if this process proceeds too rapidly, the solution should be diluted with an equal bulk of water. Let the operator, until he gains experience, be careful to rinse the negative under the tap each time before he holds it up to examine it before the gas lamp, lest perchance his solution runs in tears down the negative. If it does this, streaks will be formed down the picture which will hopelessly spoil it. A good washing for two hours is necessary to eliminate the hypo, and let the plate be gently rubbed with cotton wool soaked in water before taking it out to dry.

Occasionally exactly the reverse may be desired: the operator may have taken an excellent photograph of a difficult object—especially, perhaps, of a diatom, and which would suit his requirements if it were only a little more dense. To intensify this is a simple process and there are many formulæ: here follows the one we use and the method. The *dried* negative is thoroughly re-wetted and placed in a concentrated solution of perchloride of mercury. It turns completely white. When white *all the way through*, let it be well washed for half an hour, and then returned to the developing dish, into which should be poured some of the hydroquinone developer. The negative will turn rapidly black. When this is seen on looking *through* the negative to be complete, more washing must be carried out for an hour. Streaks and spots arise nearly always from too short and inadequate washing. If it be desired a very dilute solution of ammonia may be used instead of the hydroquinone developer. We think for portraiture ammonia is the better; but for diatoms, bacteria, and other microscopical work we prefer the hydroquinone. The operator should be careful not to allow the fluids *to touch his fingers* more than possible, wearing finger tips if he can procure them, for a stain results which is most difficult to remove.

Let us now place a half-inch objective on the microscope and use it with what is called a "projection" eye-piece. This eye-piece is made especially for projection purposes, and can be procured for achromatics as well as apochromatics. It has a considerably smaller field than the ordinary eye-piece, such being limited by a diaphragm which is meant to be focussed on the ground glass by a slight turning of the front lens. When this diaphragm is so focussed, the eye-piece performs at its best.

Let us use the same slide of the proboscis, but try this time to get details of some one or more of the smaller suctorial tubes. These should now be seen, if the objective be a good one, very sharply defined on the ground glass, but it must be borne in mind that the low-power condenser used at first should be removed and one of higher N. A. substituted, otherwise the full benefit of the higher N. A. of the objective may be impaired. We must now, too, be more careful about centring the condenser, the limelight, and the auxiliary lens, for errors of no consequence when using the inch objective are now of more importance.

The exposure will have to be increased, and as the attention of the author has been called to the fact that most writers afford little information *upon the subject of exposure*, and as we desire to make what we have to say practical and instructive, so we will try and make an attempt to be as explicit as possible.

Theoretically the time of exposure in cases like this increases in the same ratio as the squares of the diameters, or directly as the variation of the areas, *i.e.*, if twice the diameter (four times the area), it will be as 1 to 4. Put another way, supposing the first picture is magnified 25 diameters, and the second 50 diameters, the exposure varies as $25^2 : 50^2$, or as 625 : 2500, which is as 1 : 4. If then the first negative was found to require two seconds' exposure, the second one should receive eight seconds.

This law holds good as a *general guide*, but it is not always found to be practically correct, owing to the presence of a source of error hitherto not mentioned, and one not so easy to intelligibly explain. When a specimen is photographed in its *entirety* any small portions of it more dense than the rest become lost and unnoticed in the photograph when taken *as a whole*; by which is meant the lack of sufficient exposure in *these minute parts* of the specimen is unobserved. But when taking a photo-micrograph at a higher scale of magnification it is evident if we get *one of these very places* to photograph, the law will not apparently serve us correctly, furnishing us very likely with too short an exposure. But it is not the law that is at fault; on the contrary, it is really quite correct, for the very portion of the specimen which we have said escaped the proper exposure before, now shows how clearly it was under-exposed. But this may not strike the observer until after a little consideration. Anyhow, the law furnishes us with an approximation if we have taken a photograph with a low power first as described. But what if we have not, and are asked to take a photo of a tissue at 300 diameters without any previous experience? Speaking only of the limelight mixed jet, it is a good rule to give an exposure (300 diameters being the magnification) of about twenty seconds for the first plate and sixty for the second. It will be evident then on which side of scale we shall have to proceed. If over-exposed, such is the latitude of the Edwards plate that we may most probably save the picture.

When using the $\frac{1}{2}$ inch, the Davis diaphragm must be touched with a lighter hand than before, and focussing becomes more of an art, and the head should be withdrawn from the ground glass about ten inches, whilst a good dark focussing cloth excludes all extraneous light. If any minute details are desired the coarse ground glass might be removed for the finer one, after the photographer has made sure the light is equal over the plate, and then if necessary the finest of all can be substituted, a Dallmeyer or other focusser being applied while the operator turns his focussing screw gently to and fro till he gets the best results. Great care must be exercised not to shake the apparatus, as if we are using a six projection eye-piece, a $\frac{1}{2}$ inch objective and a twenty-inch extension of our camera, which in our case is done by adding the auxiliary

front, it must be remembered one is dealing with a linear magnification of 240 diameters, and, therefore, any shake is itself magnified that number of times *in all directions*.

It is time now for us to enter into and discuss a phase of our subject, which, although it is of a most engrossing nature and one which has a most important bearing upon things photo-micrographical, yet is very frequently overlooked, and perhaps with some photographers very slightly understood.

It has been plainly pointed out that the apochromatic objective can stand eye-piecing to almost any reasonable extent, and the effect or outcome of this excessively useful property is that magnification of *the same amount* may be obtained by *very different combinations of objective and eye-piece*, putting aside for the moment the utility of different camera lengths. As an instance, just for example' sake, take the following illustration. It is required to magnify an object *about* 250 diameters. This can be obtained in the following manner :

| | | | | | | |
|----|----------------------|--------------|---------|-----------|--------|--------------|
| 1. | With the 1 inch apo. | N. A. '3 | and a 4 | eye-piece | and 60 | inch camera. |
| 2. | " 1 | " N. A. '3 | " 24 | " 10 | " " | " |
| 3. | " $\frac{1}{2}$ | " N. A. '65 | " 10 | " 12 | " " | " |
| 4. | " $\frac{1}{6}$ | " N. A. '95 | " 4 | " 10 | " " | " |
| 5. | " $\frac{1}{8}$ | " N. A. 1'40 | " 3 | " 10 | " " | " |
| 6. | " $\frac{1}{12}$ | " N. A. 1'40 | " 2 | " 10 | " " | " |

Which, then, is the best? Here we have to pause and ask ourselves, first, what is required to be represented in the photograph?

(a) Is it to show the *finest details that can be possibly effected in one plane*, disregarding altogether the relation of any one part to the whole? or is it

(β) That a *general view* with as much detail as possible is required of the *large* objects, but not so much of the *small*? or

(γ) Merely a general idea of an object with just enough of the leading points to make a recognisable picture and to show *as many planes in focus at one time as possible*?

Before returning an answer to these questions, we must remind the reader that we have explained in a recent chapter, when speaking about lenses, that although "penetrating power" varies inversely as the *square* of the magnifying power, still it also varies *inversely as the N. A. of the objective*. Now with respect to the magnifying power in the present case before us, we have nothing to say, as with each combination the amplitude obtained is practically the same; but it is to the effect

produced *by change in the N. A. of the system* that the attention of the reader must be directed. A word in explanation may here be given. To say that this variation is inversely as the N. A. is only another way of expressing the fact that it varies directly as the reciprocal of N. A., and as the reciprocal of N. A. is expressed by $(\frac{1}{N.A.})$ a ready method of comparing the penetrating power of the different apochromatic powers used is afforded by a study of the accompanying table.

| | | | | | | | | |
|----------------|---|---|---|---|---|---|---|-------|
| For N. A. 0.30 | . | . | . | . | . | . | . | 3.333 |
| " 0.65 | . | . | . | . | . | . | . | 1.538 |
| " 0.95 | . | . | . | . | . | . | . | 1.053 |
| " 1.40 | . | . | . | . | . | . | . | 0.714 |

It is quite evident that the 1-inch gives the greatest depth of focus, and that the $\frac{1}{8}$ and $\frac{1}{12}$, each of 1.40, give the least. We can now see which of the six combinations already mentioned will best suit the conditions enumerated in α , β , and γ . If the requirements are as propounded in α , where we desire the highest possible detail irrespective of depth of focus, then, small as the field would be in No. 5 or No. 6, they will be the combinations best suited for the purpose, because the details furnished will be unquestionably greater; but if (γ), where merely the general view of everything is desired everywhere, and detail a secondary object, then we should choose No. 1 or No. 2. But granted that neither the extreme of (α) nor that of (γ) suit the wishes of the photographer, then No. 3 or No. 4 will be the arrangement we should recommend for (β). Here, then, is a great opportunity for the operator to display his "individuality," for he must make his choice, and we counsel those whose experience is limited to try several of the combinations before coming to a definite conclusion.

To resume: having now focussed with the greatest care, we expose—what we think, from the considerations laid down, to be the correct amount—and develop and fix in the ordinary fashion as already described.

Another good specimen to practice upon is the foot of a very small garden spider. The substage diaphragm may here require small closure, and the Davis diaphragm just the smallest touch to gain depth of focus. It is shown in Fig. 9, Plate III.

The next class of slide which may be taken with the half-inch is a diatom. It serves to illustrate a *different type of object*. Before purchasing one—let us say an *Arachnoidiscus Ehrenberghii* (Fig. 5, Plate III.)—the photographer must assure himself it is mounted perfectly flat on the cover-glass and in a highly refractive medium. We know of no mounter of diatoms in the United Kingdom that can surpass Mr.

Firth, of Clifton Park Avenue, Belfast, and few that can equal him, save Mr. Gatrell, of Barnes, whose work is of the most excellent quality ; * but Thum, of Leipzig, and Möller, of Wedel Holstein, also supply slides of exceptional merit and perfection. We think they can be obtained at Messrs. Watson & Sons, and at Baker's, both addresses being in Holborn.

In photographing diatoms, apochromatics become almost a necessity—certainly so with high powers—for the manner they seem to pick out the details devoid of all secondary spectrum colours must be seen to be appreciated. Recently, however, the new achromatics, when used with “ screens,” as hereafter explained, give very fair results.

Critical light is *an absolute necessity*, but the iris will usually want a small amount of closing ; in other words, too large a “ solid cone ” is not advisable, but, if too small, the minute markings will seem to have thick cumbersome black edges (see Fig. 2, Plate III.). No coloured glasses or screens are usually necessary with these objects. Expose fully about five to twenty seconds and develop deeply, and clear afterwards if necessary. Great care in centring the condenser is obligatory, and the light must be narrowly watched to see it is quite even. If a good negative be procured it can be subsequently enlarged to almost any amount. We have experienced no difficulty in producing a secondary enlargement up to 1800 diameters on Ilford rapid bromide paper in the manner already described of the diatom shown Fig. 5, Plate III.

If achromatics be employed instead of apochromatics, it is mostly necessary to employ a screen. A yellow one is good, but personally we have found a pot-green glass give better results with an Edwards' Isochromatic medium plate (Fig. 1, Plate III.).

(ii) **Taking the Photographs with Different Methods of Illuminating the Object.**—Taking a photograph by *direct light* is that which has just been considered for it is the ordinary method (1) as shown in Figs. 24A and B. We now proceed in this section to explain how to take the photograph with the other different forms of illumination described in Section I. of this chapter. First by *reflected light*. As before stated reflected light is only employed in photo-micrography when using an upright apparatus shown in Figs. 25, 26, 27, pages 56, 57. It has been also stated previously, that nearly always the flat side of the mirror is used for high-power objectives and the curved for low-power ones such as the inch. This may not *always* be the case : the prudent observer should try both.

* Whilst these pages are passing through the press Mr. Gatrell has sent us some amphipleura pellucida mounted in realgar and other diatoms in quinidine and piperine which are of the highest order of merit, especially the amphipleura pellucida, which of late have been so difficult to obtain.

With respect to the microscope :

Personally, we have found that the microscope is best placed on a solid floor, the limelight there too with the gas bottles in suitable position. The mirror (flat side usually) is protected from extreme light by a green glass, and the water-bath and auxiliary condenser added. The mirror must be fidgetted about until the specimen, whether one for high- or low-powers, is properly illuminated, the microscope of course being quite upright. Here is the first difficulty. It is not easy to get the mirror *in situ* when the microscope is out of its usual position ; too little room is often allowed for the operator to apply his fingers to the delicate substage movements, especially that of adjusting the diaphragm. Presuming this is accomplished, the wooden apparatus is now placed *over* the microscope without touching it, which is not always so easy as may be imagined. The union, which had better be by a velvet bag, is then made between microscope and camera. The operator now is able to stand or gently kneel whilst he completes his focussing. The light is cut off the mirror before exposing, by the use of a large black card interposed between the light and the mirror. It will be seen on consideration how very much more fatigue is entailed by the use of this apparatus. In Dr. Van Heurck's design, Fig. 25, the camera is kept fixed *in situ* over the microscope, and the operator puts his head *inside* it through the door to primarily focus with, and is said to find it most comfortable ; whilst to finish on the ground glass, he uses a stool. In Zeiss's last apparatus, as will be seen by inspecting Figs. 26, 27, p. 57, it is easy to shift the camera without much trouble.

Whilst personally never using a vertical apparatus save when the nature of the specimen demanded it, still we feel it incumbent to add that all the excellent work done by Dr. Van Heurck and which in some instances has rarely ever been equalled and never surpassed, was all done by his special form of upright camera and therefore he very justly champions its cause, and challenges other workers to try it before using the more ordinary horizontal apparatus which he has now discarded. One great objection in the upright apparatus is that all high magnification must be obtained by eye-piecing, and hence the use of camera "length" for that purpose is lost.

We should add that we hear the upright apparatus sold by Baker, Beck, Reichbert and Leitz, well spoken of by those who should give us trustworthy information. We understand too that lately our justly praised fellow-worker, Mr. Pringle, has designed a still more elaborate upright arrangement and that it is made by Messrs. Watson & Sons to his satisfaction.

It is needless to add that the description given here when the apparatus is used

with low-powers, equally applies to when it may be employed with high ones. Owing however, to no magnification comparatively being obtained by camera length, so subsequent enlargement *must* be resorted to. Dr. Van Heurck does this regularly and considers it we are led to believe the best method. It is certainly easier than photographing directly to say 3000 diameters, but we are doubtful as to the superiority of the result in all cases.

The use of oblique light is hardly ever required in medium-power work unless it is when employing a sixth. There is little to be described about it save that in applying it to the condenser as shown in another place, p. 94, considerable care has to be exercised that diffraction effects produced optically in the specimen may not be mistaken for realities of structure. The auxiliary condenser must be shifted about *laterally* to produce the best effect, and some form of elliptically or otherwise cut diaphragm (see Fig. 48, p. 95, and Fig. 53, p. 100) placed underneath the substage condenser.

Dark Ground Illumination.—In a previous section (p. 112) it is explained how this is obtained, it only remains to give a few directions as to taking the photograph with its use. Considerable care must be *taken to keep* the dark ground as *clear* and free from deposit as possible *during development*. Adding a little extra bromide from time to time is useful, although it slows the process; and great additional care should be exercised, especially when using isochromatic plates, that the dark room lamp is kept well down and that the dish should be continuously covered, both of which are to prevent any trace of fog.

Photographing Opaque Objects.—The arrangements for this purpose, when requiring a magnification of only a few diameters, has been spoken of (p. 113); but in what follows reference is made to amplifications which require the actual use of the microscope.

The position of the illuminants is much the same as previously mentioned, but it will be found far more difficult to prevent the shadow of the objective—say when using a half inch—being cast on the object itself. In other words equal illumination is most difficult to obtain. Several methods have, however, been adopted. One is the use of a Lieberkuhn, which may be said to consist of a hollow mirror, through whose axis the object glass just protrudes. The light passing through the slip around the specimen in the ordinary fashion—by which is meant that part which is not intercepted by the opaque object or its background—is cast back by the parabolic reflector on to the object to be photographed.

This arrangement will sometimes give surprisingly fine results, but as often, too, those which are most disappointing; we cannot recommend it except under exceptionally favourable circumstances, which means that the object and background are just

the right size not to cut off too much light from the reflector, and another that the adjustments of the reflector shall be such as to just cause the light to fall evenly and yet with a certain amount of diffusion over the entire specimen.

Fig. 6, Plate V., was done by this means.

A parabolic reflector, placed on *one* side only of the specimen and so arranged as to be illuminated from a jet placed on the other side, is often of use with very low powers, but does not appear to be very effective with any power above a $\frac{1}{2}$ inch.

Zeiss, Powell and Lealand, Watson, and some others also make different forms of illuminators for opaque objects which are constructed on the principle that a side light is so bent by a reflector or by a prism as to pass *through* the objective on to the specimen, thence back again through the objective to the eye. Personally we confess to have had but little success with the arrangement; so far as we have tried it we are not impressed by its utility. It is shown in Fig. 63.

Arranging the Apparatus and taking a Photograph with Polarised Light.—It has been explained on page 114 the general detail of the arrangement. Seeing so much light is lost by polarisation, and seeing, too, that every angle-of-rotation of the nicol on its axis varies still more or still less the light which falls on the plate, so it is impossible to furnish any more than an idea of exposure. Very fine results can be obtained by the use of crystals of numerous substances which have been dissolved in some solvent, dropped on to a cover glass, dried and so crystallised and then dry mounted. These, although not so pretty to the eye, photograph well without the selenite plate or the mica strip. A short list is given in the footnote.* The negative should be developed very strongly and very hard, to give the most striking contrast, and the exposure increased about one-third: this varies every time the nicol is turned so it may require to be increased to twice the usual amount.

Fig. 63

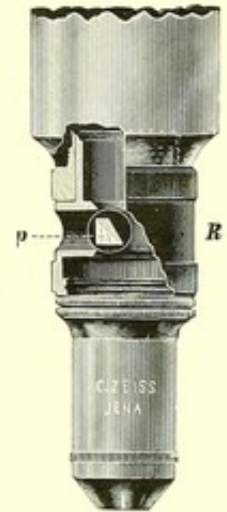

* The following make good specimens either with or without a selenite :

| | | |
|----------------------|-----------------------------|---|
| Salicine | Asparagin | Sulphates of magnesium and copper |
| Bitartrate of potash | Chlorate of potash | — |
| Salicylic acid | Borax | |
| Sulphate of copper | Citric acid | Leg of a black beetle |
| Oxalic acid | Menthol | A thin piece of horn |
| Phosphate of ammonia | Platino-cyanide of magnesia | A slip of a quill pen |
| Santonine | Cane sugar | A thin grinding of flint and some other rocks |
| Pyrogallic acid | Thymol | |

CHAPTER VII

HIGH-POWER, OR CRITICAL PHOTO-MICROGRAPHY

Section (i) In this division it is shown how to photograph several types of different test objects, to which is added a few remarks on the special development of the negatives required, whilst in

Section (ii) The photography of bacteria is fully explained.

High-power photo-micrography is the ambition of the photographer. To approach perfection in it requires more than a trial or two on behalf of the operator, whilst to bring it to absolute perfection he must become a microscopist of the highest order. Dr. Dallinger has said that "exhibiting specimens really well, is 'an art,' and not one to be acquired in a moment."

In both sections of this chapter the theory involved is not now considered, nor the reason "why" gone into: they consist, in reality, of a series of short paragraphs showing what, in the writer's experience, is necessary with respect to the general arrangement of the apparatus to produce photographs of certain well-known test objects, special types of differing difficulty being selected. They are all illustrated, and reference to the plates will be made from time to time.

Polyxenus lagurus.—The hair of the pencil tail. Fig. 7, Plate III.

We commence with one of the easiest types of specimen, it is the hair of the Pencil tail, and for that we use a sixth apochromatic, though we do not here imply that good photographs cannot be taken with monochromatic light, stained plates and *achromatic* objectives; but we feel confident, for the best results, nothing but the purest of apochromatics by either Powell & Lealand, or Zeiss, and perhaps Reichert or Leitz, should be used.

This innocent-looking little hair is an excellent test for *colour correction* of the objective, and few lenses but the very best will show the object *white* between its border lines. If a photograph be taken, then, with a badly corrected objective, the white portions will look dirty, and the object, instead of standing out cleanly cut,

will look as if it was steeped in mud. The N. A. 1.0 condenser must be used, and we confess to have a predilection for Powell & Lealand's new apochromatic, Conrady's N.A. .95, or the new Parachromatic by Watson. If we use Powell's, as it is not quite free from spherical aberration, it must be centred *with the greatest of care*. First, then, close the iris as small as possible, lower the condenser till the image of the hole is seen with a low eye-piece, centre it and re-obtain critical light. Expose, about five to ten seconds; it is short, but the object is exceedingly faint. Slightly close the iris *with caution* and open the Davis diaphragm.

Navicula spectabilis, Fig. 12, Plate V., may also be photographed with the $\frac{1}{8}$ objective, but we prefer the $\frac{1}{8}$. Keep the diaphragm rather more closed and widely open the Davis; the exposure about the same. This specimen is not easy to do because of the *thickness* of the structure. If the iris be too much closed, diffraction effects will spoil the final result.

We proceed now to a more difficult, in point of fact the most difficult part of the subject. We refer to the use of the $\frac{1}{8}$ and $\frac{1}{2}$ immersions. We must premise our remarks upon the use of these lenses by saying that as the $\frac{1}{8}$ and $\frac{1}{2}$ apochromatics each have a N. A. of 1.40, so nothing save magnification is gained by one power over the other. With respect purely to our own personal experience we find that for general work, excepting that of photographing bacteria, no lens ever made, that we have seen, and we have tested a good many in the last twenty years, can compare with the 3 mm. apochromatic made by Zeiss. A large working distance, excellent definition, and a perfection of optical centring are all combined in this lens. For photographing *diatoms* we know no equal. It will stand a 27 eye-piece with suitable objects without producing the faintest falling-off in any respect! But for *bacteria*, we do not find the field is so flat as we could desire, and the $\frac{1}{2}$ by Powell & Lealand, especially made for this work, whilst not rendering such good performance with diatoms, is far better for the purpose. The field is so much flatter in the Powell lens, whilst the definition of the faintest flagellum is superb. Hence for diatoms we always employ the Zeiss 3 mm., and for bacteria the Powell & Lealand. It must be distinctly understood here by the reader that nothing invidious is meant by the above remarks, and in stating our experience it is only given for what it is worth with the objectives in our actual possession and may not be in accord with that of others.

With these high powers it is needless to point out that only a very small portion of a specimen can be photographed at one given time; hence it has to be carefully searched for a typical place in case of tissues, bacilli, &c., and for a well-marked and evenly mounted specimen when dealing with diatoms. It is best to do this at *some*

time previous to taking the photograph; in fact, to do it at one's leisure, noting the place by the Verniers attached to the mechanical stage. By this means, when the actual photograph is to be taken, the Verniers have only to be reset, and no search made at the time.

We say this because searching for an object when the microscope is horizontally placed on the table necessitates a continued bending of the body over it, which is certainly fatiguing. This is a fault we are aware of in our own arrangement, about which we have spoken, and it is remedied to a degree in the best forms of expensive apparatus sold ready made, by having a sort of turntable to the microscope, which allows the whole instrument, with its jet and condensers, to rotate away from the camera, and permits the operator to hunt through the specimen certainly with more comfort than is afforded by the use of our own plan. This we willingly admit, but what we personally have found is that it is far better, as previously pointed out, at some *other time* to have searched through the slide, and not to leave it to the moment of *taking the picture*. Hence the loss of this arrangement, which adds sensibly to the expense, is more apparent than real.

Let us select a *Navicula lyra*, Fig. 11, Plate III., and, having oiled the immersion objective to the cover-glass and obtained critical light, we may for the specimen under consideration close the iris diaphragm a little, taking *especial care* to avoid diffraction effects. The attention of the photographer must be very close, or they may be very easily overlooked. The auxiliary lens had better be used, and perhaps the *faintest amount* of oblique light, to "show up" up the dots. It is not an easy object to take, as the diatom itself is not flat, being as its name implies—boat-shaped. Occasionally monochromatic light—green is very good—may be employed. The photograph shown in Fig. 11, Plate III., should be compared with Fig. 10. The better definition in the former is due to the superior N. A. of the $\frac{1}{8}$ over the $\frac{1}{2}$ inch.

It may require half to a minute's exposure with the pot-green, but with Gifford's F lens screen a trifle shorter time—although considerably less if without. The exact time is difficult to state, for with these high magnifications the state of the lens, its quality, and the purity of the gases used, not to mention the blending of the two gases at their best illuminating power, are all such variable and yet such important factors. Of these one should be especially mentioned, it is the purity of both gases. The limes, it is true, are difficult to get good, but when a good tin is opened, and if kept well shut down when not in use, all of its contents are mostly of the same quality. But with the gases it is different. The amateur cannot test either without elaborate means, not often at his disposal. Hence he may sometimes find that his

exposures go wrong when he least expects it, entirely owing—or anyhow very largely—to his oxygen being exceedingly impure. To prevent any accident of this kind, at Brin's oxygen works the oxygen is tested almost hourly, and users need have but little fear that it is absolutely of the finest quality, which cannot be said of the producers at cheap rates, for the writer has heard of some instances where it was so very largely adulterated as to be next to useless. Another source of trouble will come from a blackening of the lime during the exposure, which lessens the brilliancy perhaps some 20 per cent. The firm to whom we have alluded have made this an especial subject of study, and distinctly traced it to impurities in the coal-gas, which when compressed have some ill-defined chemical action on the steel of the tube itself. After much consideration and experiment they have found that it can be very largely—if not entirely—cured by coating the inside of the coal-gas cylinder with a dressing which, whilst preventing the gas attacking the metal, in no way alters its chemical properties. We have had our own coal-gas cylinder dressed this way, and so far have found it very successful.

[It is interesting now to take the same diatom with a half-inch N. A. '65, using a high eye-piece or camera length to get the same magnification. It will be found that although the pictures are of the same size, one reveals the dots and the other does not, or if it does at all, most imperfectly. This is an illustration of the value of numerical aperture, and has been alluded to above. See Fig. 10, Plate III.]

Navicula rhomboides, Fig. 8, Plate IV. This specimen is a difficult one. No oblique light is necessary and the "iris" must not be too much closed. Owing to the specimen rarely being flat, focussing is extremely difficult and it is not often a photograph can be taken with the dots *equally* sharp all over the *whole* picture. Like the pleurosigma angulatum, this specimen is best photographed up to 1000, and then *re-enlarged* from the primary negative.

Coscinodiscus asteromphalus, Fig. 6, Plate IV., selecting, of course, the fine secondary markings, is also a specimen which requires considerable patience. These require a faint trace of oblique light, and in the Zeiss pattern microscope that is easily effected by turning the screw of the oblique-light-motion just a touch. In other microscopes the auxiliary condenser and the light will require setting obliquely to a small amount, or if using a mirror to reflect the light up the microscope it will have to be somewhat obliquely placed. Focussing becomes now quite an art, and the operator must not be disappointed if he has to take several negatives to get one really well in focus. The diaphragm will require careful adjustment for this object, but the Davis' must be opened wide. Exposure will here vary greatly according

to the amount of oblique light; and if a faint negative be obtained it is better at once to give three times the exposure to the next one. It may be better to use a monochromatic screen or glass as used in our case when taking the photograph shown in Fig. 6, Plate IV.; but this varies very much with the ability of the operator, the amount of oblique light used, and the beauty of the specimen, for some are so much better marked than others. It is not at all improbable the photographer may here require to use a 1.35 condenser because it admits so much more light at any given obliquity. We can strongly recommend the new one by Conrady, or the well-known N. A. 1.40 by Powell & Lealand, Fig. 53, p. 100.

Seeing we may be now using over 1000 diameters, according to the eye-piece used and the camera length, the greatest attention must be exercised in all adjustments, and the dark slide must be put into the camera in the most gentle manner possible, whilst opening the draw-slide cannot be effected with too much care. Centering the condensers and the light become now more than ever acts of refinement, and all movements around or about the table whilst taking the photograph must be strictly forbidden, even though it is supported on cement feet apart from the floor.

The *Pleurosigma angulatum*, Figs. 5 and 10, Plate IV., is another test object and one of classical interest. It can be procured, mounted on the cover-glass, which means in air, or in a highly refractive medium such as realgar. It has *two* principal planes of focus, and much difference of opinion exists as to which is the correct one. For some reason, which is not very easy to discover, many microscopists find the diatom easier to photograph if mounted in air; and the easier plane of focus, that one adopted by Dr. Zeiss in his celebrated picture, where black hexagonal marking surrounds a white centre. But other authorities are equally strong in their opinion that the true focus is where the hexagonal markings are white and the centre portions dark. The last pictures taken by Dr. Van Heurck with the new Zeiss N. A. 1.6 objective and the attendant paraphernalia seem to show that after all the "black dot" may be more correct than the white one. As before stated, the white one is the easier to photograph, for the dark dot seems never to be sufficiently defined to look as sharp as we should like it. It is also more often ovate, and this peculiarity we have often noticed in photographs taken by others more experienced than ourselves. No arrangement that we are aware of will cure this peculiar defect, but it is easy to overlook unless special attention be paid to the point.

When specimens are mounted in realgar another appearance may often be seen. It has been called the "pearl dot" where each white dot—which is now seen dusky around its base—seems literally elevated from its surroundings, whilst it is crowned

at its summit by a very pronounced white tip, the so-called "pearl." Of course this is an optical phenomenon, but it is very beautiful in some specimens. A small piece is shown in the upper part of Fig. 5, Plate IV.

In photographing the white dot plane of focus—the first we mentioned, Fig. 10, Plate IV.—a narrow illuminating cone is required, and perhaps a touch of the faintest kind of "oblique light," too much will make the black hexagonals look elongated and distorted. With the black dot plane of focus (Fig. 5, Plate IV.) no oblique light should be used, but the cone of light issuing through the condenser should be carefully controlled by the iris so as to get the best effects without more closure than possible. As we have before stated, it is not easy to get the definition so perfect at this plane of focus, as will be seen by inspecting pictures taken by the few who have given attention to the matter. Green light may be used with advantage.

To refer again to the "pearl dots," we have personally never been able either to see them well or to photograph them, unless the specimen was mounted in realgar—hence we are led to suppose their presence is in some way due to the high refractive index of the mountant. Use a narrow cone. Occasionally it may be necessary to employ an Edwards "Snapshot" plate, which is four times quicker than a "Medium" one.

A somewhat peculiar point should here be mentioned before we leave this specimen. It has been noticed by us that to obtain a photo direct of much above a 1000 diameters is a most difficult thing, no matter what plane of focus, the result has never been what we call good. We have seen the attempts of others, too, and have never been satisfied with their results. The only way to get increased amplification is to re-enlarge the negative, a plan adopted by several of the best photo-micrographers, including Dr. Van Heurck. It is curious to state this, because with our next specimen, the *Surirella gemma*, there is no difficulty in doing so, even up to 3000 diameters.

Surirella gemma (Fig. 9, Plate IV.).—Oblique light is here needed, and a specimen mounted in realgar best, and a somewhat narrow cone of light is wanted. The little dots are mostly square, ovate, or circular, sometimes all shapes being found in one specimen. They are about 50,000 to the inch. Owing to the amount of oblique light necessary, it is better to use an Edwards "Snapshot" plate. White light, exposure two minutes; 1.35 condenser, well oiled to slip.

Podura scales (Figs. 11 & 12, Plate IV.).—Scales of the *Lepidocyrtis curvicollis*. Small cone, direct light, green glass, exposure about one minute. If studied they will be found to exhibit curious markings—"notes of exclamation" as they are called. These simple black markings should be shown easily with a sixth, but of what we are about to speak, and what we may, for convenience of description, call "the white interior

of the note," requires more magnification and a little higher N. A. Indeed, to do so perfectly an eighth, with fairly high N. A. and a fairly high eye-piece, or much camera extension is required. We say a fairly high N. A. because we are aware that N. A. is not of so much consequence with this specimen. It is the *colour* correction that is of so much importance, and any failure in this respect will be readily apparent visually by showing the "white interior of the note" coloured, and photographically by failing to show it clear, clean, and well defined. Indeed, nothing but the *very best* of apochromatics exhibit this centre as *strictly and absolutely white*. Concerning definition, the white centre should in the photograph distinctly show a well-marked constriction around its neck at the broadest part, and the whiteness should be prolonged, becoming narrower and narrower until *almost a line* for about two-thirds of the entire length of the black note itself. A shadow effect (?) should also be seen under each "note." What these markings are due to is a matter of great dispute, some thinking them *depressions*, whilst others regard them as hair-like appendages.

Amphipleura pellucida, Kütz (Fig. 4, Plate IV).—Perhaps the most difficult specimen, both to obtain as well as to photograph, is an *Amphipleura pellucida*, Kütz. None that the writer has ever seen can compare with those prepared in realgar by Dr. Van Heurck, excepting those mounted by Mr. Gatrell.

Some considerable practice is necessary before the beginner can even *see* the lines, much less photograph them. It may be of service to assist him if we mention the following:—We have found that to *see* the lines no auxiliary condenser is *absolutely* necessary; we can do so perfectly, and without any difficulty measure them with the N. A. 1.0 condenser, the F line screen, and oblique light, but we admit they are better shown with the 1.35 Conrady condenser. To photograph them so that the lines shall be *pure* and of about *one-third the thickness* of the white space between any two, the auxiliary condenser, as well as the 1.35 substage condenser oiled to the slip, *must be employed*. It is also to be recollected that the final perfection of the image, as seen on the ground glass with the 18 or 27 eye-piece, should be attained by fidgetting the auxiliary condenser from side to side and up and down, rather than by using *more and more* oblique light. This point to bear in mind is of all importance, as we have found by so doing the lines are finer and the exposure enormously reduced. Without the additional condenser, and not using so wide angled or so perfect a substage condenser, we failed, after even an hour had been spent with the plate exposed, to obtain a good negative, and this we traced to the fact that the heat either caused the realgar to melt—if it may be so said—or it upset the focusing of the microscope itself. But after repeated trials we discovered the advantage

of obtaining the *perfected* image by finding the suitable position *for the auxiliary lens*, and also the advantage of using Mr. Conrady's perfectly achromatised 1.35 condenser, for we reduced the time so considerably that my son actually obtained a first-rate negative with only thirty seconds' exposure, although using the F line screen. The closeness of the lines differs with various specimens. In our case we measured them and found they were about 100,000 to the inch. Hence, if an ordinary hair of the head was split into about 480 strips, one strip would about fill the space between any two!

To photograph these lines as *dots* is the highest record for the photo-micrographical student. According to some great authorities it can only be done with a lens which has an aperture *of over* 1.40, which means an expense of no small amount, seeing that a special condenser is *also* required, let alone a slip and cover-glass cut and polished from a block of glass having the actual refractive index required for the optical combination.*

Dr. Van Heurck, however, it is believed, somewhere about 1884, with some special form of silvered preparation, made a photograph showing the lines resolved into beads, but in 1887 actually succeeded in photographing them by transparency, employing monochromatic solar illumination. We have never seen the photograph, but in 1889 the same renowned microscopist and photographer took what must be considered as his *opus magnum*, a photograph of them at 2000 diameters with the new lens. Here we must pause, for we know many authorities *entirely disagree* with the reality of these pictures, believing them to be nothing but photographs of optical phenomena, for the reader must be reminded we are dealing with objects now that are becoming commensurate with the wave lengths of light. We admit ourselves to be very uncertain, for it is *a known fact* that the phenomena displayed by the **Pleuro-sigma angulatum** have been the subject of mathematical inquiry, and it is maintained by no less an authority than that of Professor Abbe himself, that the mathematician can accurately show what the details of this image should be in direct accordance with *the number of diffraction spectra that the objective itself has transmitted*. Hence, in the case of this diatom, theory indicated the *optical* but not necessarily the *structural* existence of the tiny markings. Dr. Eichhorn actually made the calculations of their size and shape without knowing of their existence, and when Mr. Stephenson re-examined the object with annular light he actually saw them, and Dr. Zeiss *has since been able to photograph them*. If, then, this be true with the **Pleurosigma angulatum**, why should it not apply to the **Amphipleura pellucida** equally well?

* The obliquity of the light to show *the lines* should be at right angles to them—up and down the specimen; but *in their direction*, that is, across the specimen, to show the dots. Monochromatic sunlight must be used for the latter.

Another disturbing appearance is that of a distinct image of the dots being occasionally seen *outside the diatom itself*, lying in space! Here we are confronted with an exhibition that nothing but optical phenomena can possibly explain. It is for these reasons we never employ oblique light unless it *emphasises what can be seen without its use*. If by its extreme use we benefit our pictures, but get these "outside" effects, we reject them, and only accept photographs which, it is true, may not to the eye be so elegant, or to the photo-micrographer so excellent, but to the mind which prefers unquestionable reality, will appeal all the more.

General Remarks.—In taking such objects as blood-cells, eosinophyl-cells, and the like—Fig. 7, Plate IV.—the operator will have to use a somewhat contracted cone of light, so as to bring out the definition of the edges of the principal objects, and he may have to use a touch of the Davis diaphragm to increase the definition of the little dots in the eosinophyl cells if his objective be not a very good one. The exposure when using the green pot glass will be about half a minute. Development must not be carried too far, or the little dots before referred to will be clogged up.

It should be remarked that the difficulty with all diatoms is to get a sufficiently dense negative, especially when using *high magnifications*. This trouble always arises from *under-exposure*. When developing, the operator must not think his negative *over-exposed* because it appears to "come up" quickly. The rapid development of the image will always be present in diatoms because it is obvious the whole plate is exposed to almost the same amount of light; the only interception to it being the thin markings of the diatom itself.

Memoranda.—With green screens, say with the Gifford F line, the exposure has usually to be augmented about three times; with a red screen and a Lumière red-stained plate about four times; with these employ amidol for a developer, as Hydrokinone fogs them. With yellow screens about twice the exposure is sufficient—Edwards plate; whilst with violet screens and Edwards plate hardly *any* increase is required. Occasionally it may be necessary to gain sufficient density to use an Edwards "Snapshot" plate. It is four times quicker than the "Medium." Develop deeply. Do not have quite so much soda in developer.

In comparing the photographs taken by different lenses the same N. A. should be utilised if a faithful comparison is to be made.

All immersion lenses work quicker than dry ones: for example, a dry sixth works *slower* than an immersion $\frac{1}{1\frac{1}{2}}$ th with the same amplification.

Some diatoms are easier to photograph than others. The *Navicula spectabilis* is a fairly easy one and often selected to show how achromatics compare with apochromatics,

see Fig. 12, Plate V.; but the pronounced superiority of the apochromatic becomes more immediately apparent in the fine markings of *faint* diatoms such as the *Amphipleura pellucida*, the *Surirella gemma* and the *Coscinodiscus asteromphalus*.

In making nikko prints do not over expose: well develop to get plenty of comparison and contrast. Keep the developing solutions very strong to get black prints and not brown ones.

(ii) **Photographing Bacteria.**—Bacteria in their *natural unstained state* are exceedingly small, and for the most part colourless and structureless bodies of protoplasmoidal matter assuming all manner of shapes and having such a high refractive index as to be most difficult to see—even with a magnification of 1000 diameters, and still more difficult to photograph.

Although these little organisms can be artificially stained by solutions of many substances, still, each variety seems to have a more or less well-marked selective power of absorbing the colouring matter of one or two special dyes in preference to that of any other. Hence, as the photo-micrographer meets with this type of work he must expect not only all varieties of shape, but all varieties of colour also.

The difficulty noticed by all photographers in obtaining a well-contrasted print of these little bodies depends solely upon the fact that the dyes with which the organisms are stained do not affect the photographic plate in the same manner and to the same extent as they do the eye. For example, a slide may be a very excellent one from a bacteriological point of view, and owing to the selective colouring of the organism as compared with that of the background, may be of a most impressive nature, yet it will not yield an equally contrasted print. On consideration, the reason for this apparent anomaly is not far to seek. Contrast *visually* was obtained by differentiation of *colour rendering* between the bacillus and the background, whereas in the photograph it must depend upon *what effect each colour can cause on the plate*. Put another way, contrast visually is due to duality of colour rendering, whereas in the print it alone depends upon what amount of differentiation in terms of black and white the colours employed as stains have been able chemically to produce—by deposition of silver—in the emulsion which covers the plate.

The aim, then, of the operator must be to increase the difference in these deposit ratios as far as he possibly can.

To understand how this can be effected, the attention of the reader is directed to the following:—

1. Colour sensation to the eye is dependent upon the wave length of the light employed. The longest wave gives rise to the red sensation, and the shortest to the

the violet; intermediate lengths being productive of sensations we call yellow, yellow-green, green, greenish-blue, blue and blue-violet.

2. The ordinary photograph is taken by the violet ray, because the usual emulsion is most sensitive to that particular wave length. Plates, however, can be stained to be extra sensitive in any one or more colours, but even then with this extra sensitiveness, the action of the violet is always the strongest, *i.e.*, more precipitation of silver—time for time—is produced with violet light than any other colour.

3. Ordinary light, whether daylight, electric or lime light, consists of a blending in certain proportions of rays of all wave lengths.

4. An ideally perfect monochromatic screen is one that intercepts all other wave lengths save the one it passes. A red screen, therefore, cuts off (probably converts into heat) all other rays, save the red ones; blue cuts off all but the blue, and so on. It is difficult to obtain a really monochromatic screen, and impossible to obtain a glass ideally perfect, save perhaps in the case of red glass. It must also be noted that perfection of monochromatism also depends on *the strength of the illuminant*, that is to say, a screen may be almost perfect with a weak light, but far from perfect with a strong one.

5. The effect of placing two different monochromatic screens, each ideally perfect and of the same intensity, over one another would be to cause blackness, such blackness being the more perfect the more intense the screens or the feebler the white light—screens of differing intensity vary in their effect according to such variation, by which is meant an intense red and a feeble green will allow a residuum of red—a strong green and a thin red, a residuum of green, and so on.

As ideally perfect monochromatic screens are obtainable with such difficulty, it may be well to point out that red filters often pass a little yellow; blue ones often a little red; green ones occasionally a little blue, and often red; whilst yellow ones are rarely pure at all, permitting red and green rays to pass to some considerable amount. If, now, a blue passing red be placed over a good green, but one passing a modicum of red, and provided the light be intense enough, a dark, deep red residuum is noticed instead of blackness. This is obviously caused by the green and violet causing darkness, but not sufficient to annihilate the reds from each glass.

6. In practice, owing, of course, to impurities, it is found that some colours are more antithetical than others. Red and green, for example, usually produce greater blackness than red and orange, a fact which we shall presently explain is made use of at times.

Now with these six precepts before us we hope to show how the photographer can increase the contrast in his negative, and so, of course, in the print which is taken from it.

Let it be presumed he has taken an ordinary photograph of a red bacillus on a

white ground, with blue-stained nuclei of cells interspersed about. He finds a flat result, a negative that produces a wretchedly poor print lacking all contrast. Now let him place a fairly strong green screen over the illuminant and use a green-stained plate to shorten exposure. The resulting negative will show clear patches of glass corresponding to the red bacilli, a fairly clear deposit for the blue nuclei and an intensely black one for the background. If the bacilli are too clear, so much so that any little alteration of structure, such as segregation, seems lost, then let him use a fainter green or employ a brighter light, and the result may be good. If still not satisfactory let him try an orange screen, for as that colour is not so antithetical as green is to red, it will allow a little more light to pass.

The resulting print will give, of course, a black bacillus, a well-defined appearance of the scattered nuclei, while both bodies are seen lying on a clear white background. The whole picture is full of contrast and pluck.

As a matter of fact pure monochromatic screens for photo-micrographing bacteria are not required, good pot glasses are amply sufficient, for be it understood it is only the *increase of contrast that is required*.

To be practical, then, in photographing bacteria, glasses of all colours must be procured, and also it is convenient to get several shades and several densities. For what may give rise to sufficient contrast *to the eye* with the ordinary lamp, may not be sufficient; or, perhaps, on the other hand, which is much more frequent, may be *too great* when the photograph is being taken. It would have been thought the intense limelight should always demand a still greater thickness of contrasting colour, but it is usually just the reverse, for the light is reduced considerably, *as seen on the ground-glass screen*, with that *visually viewed* at the eye end. The very fact that a virtual image is seen by the eye and an actual image viewed on the plate, entails a loss of initial light, as the rays have to again cross. This crossing is obvious, as the image is upside down to the eye, but the right way up on the plate in the camera.

Screens may be used *to increase definition* (page 107), when taking photographs of fine markings in diatoms, and the best method is to make them by mixing aniline or other colours with a specially made collodion, formed by dissolving pure celloidine in equal parts of ether and alcohol. Float the collodion over very thin glass plates—cover-glass type of glass preferable, especially flat ones—allow to dry, and cover with another protective glass, as when covering ordinary lantern slides. Malachite green, methyl green, blue and violet aniline, fuchsine, naphthol yellow, chrysoidine, all of differing quantities and densities, may be made; they may be of service.*

* Whilst these pages are passing through the press the following plan for making good screens has been suggested by

There is no special difficulty otherwise than to obtain sufficient contrast in taking photo-micrographs of bacteria when they are stained. Hydroquinone produces dense pictures which are always necessary, especially when lantern slides are required, for no background, unless it be of some specific nature, is needed, and the bacteria on clear glass look much better on the screen than when they are shown on a dirty white background.

When taking a photograph of living bacteria, such as the clumping of the typhoid germs in Widal's method of diagnosis, much difficulty may be experienced in getting a photograph at all. It is best then to take advantage of diffraction effects and to close the iris, what would be otherwise considered an undue amount. By this means a faint "standing-out" effect is produced which enables the bacteria to show sufficiently for the purpose, provided the exposure be short enough to prevent choking effects, and yet long enough to give a sufficiently dense background. We found about ten seconds with a subdued light and using a $\frac{1}{6}$ th apo. about correct. A vertical apparatus must be used, about which we have already spoken.

It should be distinctly remembered that when photographing *stained* bacteria the iris diaphragm *should never be closed*, and a full-sized cone of light *always employed*, otherwise white diffraction lines will appear around the organisms. At times we have thought that a 1.35 achromatic substage condenser gave better results, especially when photographing bacteria with flagella. Examples of this type of work are shown in Figs. 1, 2, 3, Plate IV., and Figs. 7, 8, 9 and 10, Plate V.

The story of photo-micrography is now told—at least, so far as it relates to the experience of the author; but before he lays down his pen he wishes to point out to his readers the desirability of never passing a comment upon efforts of their own or those of others without *directly comparing such with the work of the best of experts*. Comments without such comparison are often wrong, and may be most misleading. The true spirit of the photo-micrographer should be one of "effort," ever remembering the old adage, "If at first you don't succeed, try, try again." "Ever learning," then, must be his motto, and if by fair criticism founded upon the *works* and not the *words* of others he is shown his shortcomings, he must not take umbrage or be discouraged, but once more try again.

Mr. Wall—a well-known authority on such matters—and is worthy of note. Coat patent plate with a 2½ per cent. solution of albumen. When dry, pour over 170 minims of an 8 per cent. solution of gelatin. Level and allow to dry.

For Yellow Screens.—Soak in the following solution: 20 grains of picric acid dissolved to saturation in absolute alcohol, two ounces of water and a little ammonia.

For Red Screens.—Soak in a 1 per cent. solution of crysoidine.

For Orange Screens.—Soak in a 1 per cent. solution of aurantia.

For Green Screens.—Soak in a 1 per cent. solution of naphthal green, acid green, or methyl green.

For Violet Screens.—Soak in a 1 per cent. solution of methyl violet.

APPENDICES

APPENDIX I

TO ASCERTAIN THE N. A. OF AN ORDINARY PHOTOGRAPHIC LENS*

This may be deduced from the usual values stamped on the diaphragms (such as $\frac{F}{8}$ $\frac{F}{16}$ etc. etc.) as follows:

If a diaphragm is marked $\frac{F}{n}$ (n being any one of the usual figures 8.11.16.22 etc. etc.) the meaning is that the *effective* diameter D , to which it reduces the working aperture of the lens, is equal to that amount algebraically.

$$(I.) D = \frac{F}{n} \text{ or transposed } \frac{D}{F} = \frac{1}{n}.$$

On the other hand, according to Abbe, the N. A. of any lens, provided it is aplanatic, is obtained by dividing *half* its working diameter by its focus.

(II.) $N. A. = \frac{D}{2} = \frac{1}{2} \frac{D}{F}$. Introducing the value of $\frac{D}{F}$ as given in equation (I.) into (II.) we obtain

(III.) $N. A. = \frac{1}{2} \times \frac{1}{n} = \frac{1}{2n}$. This *would be* the true N. A. of the lens, *if* the object was at the principal focus, producing an infinitely magnified image at an infinite distance behind the lens. *Really*, however, the lens will be producing a moderately magnified image at a reasonable distance, and this demands that the object should be at a *greater* distance from the lens than the principal focus. At this greater distance the working diameter of the lens will subtend a smaller angle than at the principal focus, hence the N. A. will be *smaller* than that found by Equation (III.). The reduced N. A. may be found with sufficient accuracy as follows:

Let the magnification be m , then the image will be formed at a distance $(m + 1) F$ behind the optical centre of the lens, and the object will be at a distance $\frac{m + 1}{m} F$ in front of the optical centre of the lens. The distance from the object to the lens is therefore increased over that assumed in Equation (III.) in the proportion $\frac{m + 1}{m}$, and the N. A. is diminished in inverse proportion. Therefore we get the final equation

$$(IV.) \text{ For magnification } M, \text{ the actual N. A. } = \frac{m}{m + 1} \frac{1}{2n}.$$

Example: Diaphragm $\frac{F}{16}$. Introducing $n = 16$ into (III.) we get

$$\text{the N. A. at the principal focus } \frac{1}{2 \times 16} = \frac{1}{32} = \cdot 03125.$$

* I am indebted for this lucid description to the pen of Mr. Conrady.

But now let the magnification be, say, 4 diameters ($m = 4$), then we get the N. A. at which the lens works from (IV.).

$$\text{Actual N.A.} = \frac{4}{4 + 1} \cdot \frac{1}{2 \times 16} = \frac{1}{40} = \cdot 025.$$

It may be added that it is largely due to the very low N. A. of photographic lenses that they are superior to proper microscopic-objectives for the lowest forms of photo-micrography, as owing to that very low N. A. the correction of the axial pencils are not carried to any great degree of refinement; the computer then has a chance, not otherwise afforded him, to utilise the available radii and distances for the correction of astigmatism and coma of the oblique pencils, and for the obtaining of a fairly large plane of field free from objectionable distortion.

APPENDIX II

TO OBTAIN THE NUMBER OF LINES TO THE INCH IN A SPECIMEN

To obtain the number of lines to the inch; say, for example, in one of *Amphipleura pellucida*: Place on the stage a ruled micrometer, using the lines separated by an interval of $\cdot 0001$ inch. Place one of the webs of a movable parallel wire micrometer used in place of the eye-piece on one line, and the other, say, on the 6th, so that 5 spaces of $\cdot 0001$ inch are thus included between them. Take 5 readings off the head of the micrometer.

| | Revolutions. |
|--------------------------|-----------------|
| Say they are as follows: | 4·589 |
| | 4·670 |
| | 4·642 |
| | 4·680 |
| | 4·699 |
| | <u>5/23·280</u> |
| | 4·656 mean. |

Divide this mean by 5 and $\cdot 931$ of a revolution of the head of the micrometer = $\cdot 0001$ inch (I.).

Without touching the draw tube of the microscope, place the *Amphipleura pellucida in situ*, and set the wires a distance apart so as to contain a given number of lines; say, a separation sufficient to enclose 5 lines. Read the interval on the head of the micrometer. In a specimen of our own it was $\cdot 551$ of a revolution. To ascertain the value in terms of an inch:—

$$\text{as Rev. } \cdot 931 = \cdot 0001 \text{ by (I.), so } \cdot 931 : \cdot 551 :: \cdot 0001 \text{ inch.}$$

$$\text{hence } \frac{\cdot 551 \times \cdot 0001}{\cdot 931} = \text{say } \cdot 00006 \text{ inch.}$$

Five lines, then, are in every $\cdot 00006$ inch: how many in 1 inch.

$$\cdot 00006 : 1 :: 5 = \frac{5}{\cdot 00006} = 83,300.$$

If the answer be required in mm. then, as 1 inch = 25·4 mm., the 83,300 must be divided by 25·4.

The great difficulty with this method is to be quite certain that the threads of the micrometer really coincide with the minute lines of the specimen. To enable this to be as accurately done as

possible, it is necessary to employ an 18-compensating eye-piece. As this is a *positive* one the threads can be focussed just in the same fashion as with the ordinary Ramsden eye-piece, but the micrometer requires a special fitting, and, as the lenses are in such close proximity to the webs, *great care must be taken they do not touch them.* It is needless to state if this accident occurs they are nearly sure to be broken.

APPENDIX III

TO OBTAIN THE NUMBER OF LINES TO THE INCH IN A SPECIMEN
BY PHOTOGRAPHIC METHOD

Another method for obtaining the number of lines to the inch is by the photographic method. A negative is taken of the specimen, and then of a stage micrometer ruled to ten-thousandths, which is substituted. Great care must be exercised that the length of the drawtube is not touched during the process. A comparison between the two negatives is then readily made. This method is the most exact possible.

APPENDIX IV

TO DETERMINE RATE OF PERIODIC STRUCTURES TO INCH OR MM.
IN A SPECIMEN WHEN AMPLIFICATION IS KNOWN

It is often required to determine at what rate to the inch, or to the mm. periodic structures, occur in the photograph of a specimen *when the amplification is accurately known.*

Example.—An object is known to be magnified 1000 diameters, and it is found 18 dots can be counted in $\cdot 3$ of an inch when the photograph is examined. The question is, at what rate per inch is the structure?

$$\frac{\text{mag. power} \times \text{the number counted.}}{\text{space counted}}$$

$$\text{thus } \frac{1000 \times 18}{\cdot 3} = 60,000 \text{ per inch.}$$

If the answer is required in mm., seeing that 25·4 millimetres equal an inch, the amount in inches must be divided by 25·4 (Carpenter).

APPENDIX V

HOW TO USE A MILLIMETRE MEASURE FOR ASCERTAINING THE
SPACE IN WHICH A NUMBER OF PERIODIC STRUCTURES
CAN BE COUNTED TO THE INCH

Suppose a millimetre measure be used to ascertain the space in which the number of periodic structures in the photo-micrograph are counted, and the rate *per inch* is required, the method is as follows:

Example.—If, with a magnification of 675·2 diameter, 12 dots can be counted in 7 mm., then because 1 mm. = $\cdot 03937$ inch,

$$\frac{675 \cdot 2 \times 12}{7 \times \cdot 03937} = 29,400 \text{ per inch.} \quad (\text{Carpenter.})$$

APPENDIX VI

TABLE OF METRIC MEASURES WITH THEIR ENGLISH EQUIVALENTS

A metre was formerly supposed to be the $\frac{1}{100000000}$ part of the distance of the pole of the earth to the equator measured along a given meridian. Owing, however, to an error it is known now to be too short. Hence, the metre is really the length of a definite standard kept in Paris.

| | | | | | | | | | |
|--------------|--------------------------|----------------|------------------|------------|------------------|-----------|---------|---------|---|
| a micron | (usually written μ) | = | $\frac{1}{1000}$ | millimetre | = | ·00003937 | inches. | | |
| a millimetre | = | $\frac{1}{10}$ | centimetre | = | $\frac{1}{1000}$ | metre | = | ·03937 | „ |
| a centimetre | = | $\frac{1}{10}$ | decimetre | = | $\frac{1}{100}$ | metre | = | ·39370 | „ |
| a decimetre | = | | | = | $\frac{1}{10}$ | metre | = | 3·93704 | „ |

APPENDIX VII

A TABLE FOR CONVERSION OF BRITISH AND METRIC MEASURES

MICRO-MILLIMETRES &C., INTO INCHES, ETC.

| μ . | inch | mm. | inch |
|-------------------|-------------|-----------------|----------------|
| 1 | = ·000039 | 1 | = ·039370 |
| 2 | = ·000079 | 2 | = ·078741 |
| 3 | = ·000118 | 5 | = ·196852 |
| 4 | = ·000157 | 10 (1 cm.) | = ·393704 |
| 5 | = ·000197 | 20 | = ·787409 |
| 6 | = ·000236 | 50 | = 1·968522 |
| 7 | = ·000276 | 100 | = 1 decimetre. |
| 8 | = ·000315 | | |
| 9 | = ·000354 | | |
| 10 | = ·000394 | | |
| 20 | = ·000787 | | |
| 30 | = ·001181 | | |
| 40 | = ·001575 | | |
| 50 | = ·001969 | | |
| 60 | = ·002362 | | |
| 80 | = ·003150 | | |
| 100 | = ·003937 | | |
| 1000 | = 1 mm. | | |
| inch | μ . | inch | mm. |
| $\frac{1}{25000}$ | = 1·015991 | $\frac{1}{500}$ | = ·028222 |
| $\frac{1}{20000}$ | = 1·269989 | $\frac{1}{800}$ | = ·031750 |
| $\frac{1}{15000}$ | = 1·693318 | $\frac{1}{500}$ | = ·050800 |
| $\frac{1}{10000}$ | = 2·539977 | $\frac{1}{100}$ | = ·253998 |
| $\frac{1}{5000}$ | = 2·822197 | $\frac{1}{10}$ | = 2·539977 |
| $\frac{1}{5000}$ | = 5·079954 | $\frac{1}{8}$ | = 3·174972 |
| $\frac{1}{1000}$ | = 25·399772 | $\frac{1}{5}$ | = 5·079954 |
| | | $\frac{3}{8}$ | = 9·524915 |

Example.—What is the equivalent in inches to 21 μ .

$$\begin{aligned}
 20 \mu &= \cdot000787 \\
 1 \mu &= \cdot000039 \\
 \hline
 &= \cdot000826
 \end{aligned}$$

INCHES, ETC. IN MICROMILLIMETRES, ETC.

INCHES AND MILLIMETRES.

| | | |
|---------------------------|---|-----------------------|
| 5000 lines per inch | = | 197 lines per mm. |
| 10000 " " | = | 394 lines " |
| 30000 " " | = | 1·181 " " |
| 50000 " " | = | 1·968 " " |
| 25399·77 lines in an inch | = | 1 line to the μ . |
| 50799 " " " | = | 2 " " |
| 101599 " " " | = | 4 " " |
| 152399 " " " | = | 6 " " |
| 203198 " " " | = | 8 " " |
| 253998 " " " | = | 10 " " |

| | | |
|---------------------------------|---|--------------|
| $\frac{1}{50000}$ th of an inch | = | 5·08 μ . |
| $\frac{1}{100000}$ " " | = | 2·54 " " |
| $\frac{1}{200000}$ " " | = | 1·27 " " |
| $\frac{1}{300000}$ " " | = | ·508 " " |
| $\frac{1}{700000}$ " " | = | ·363 " " |
| $\frac{1}{1000000}$ " " | = | ·254 " " |

| | | |
|---------------------------|---|---------------------------------------|
| Square $\frac{1}{8}$ inch | = | 10·08045 square millimetres. |
| " $\frac{1}{16}$ " | = | 6·45148 " " |
| " $\frac{1}{32}$ " | = | 4·48021 " " |
| " $\frac{1}{64}$ " | = | ·06451 " " |
| Square μ . | = | ·00155 square $\frac{1}{10000}$ inch. |
| " 10 μ . | = | ·1550 " " " |
| " 100 μ . | = | 15·5003 " " " |

Multiples of the above may be found by multiplying the values given by the square of the multiplier. Thus, square $\frac{1}{16}$ inch = $\frac{1}{16} \times 4$; the square of 4 = $4 \times 4 = 16$, and $6·45148 \times 16 = 103·22368$ square millimetres (Carpenter abridged).

APPENDIX VIII

TABLE OF REFRACTIVE INDICES

| | Refractive index | | Refractive index |
|----------------------------|------------------|-----------------------------|------------------|
| Water | 1·333 | Fluor spar | 1·436 |
| Human blood | 1·354 | Oil of olives | 1·470 |
| Alum (sat. sol.) | 1·356 | Naphtha | 1·475 |
| Ether | 1·359 | Oil of turpentine | 1·478 |
| Albumen | 1·360 | Castor oil | 1·487 |
| Absolute alcohol | 1·366 | Cinnamon oil | 1·508 |
| Salt (sat. sol.) | 1·375 | Oil of cedar | 1·510 |

| | Refractive index | | Refractive index |
|--------------------------------------|------------------|-------------------------------------|------------------|
| Oil of cloves | 1.530 | Dense flint | 1.650 |
| Canada balsam | 1.540 | Extra dense flint | 1.710 |
| Styrax | 1.582 | | |
| Oil of cassia | about 1.626 | <i>Jena Glass</i> | |
| Monobromide of naphthaline | 1.657 | Boro-silicate crown | 1.51 |
| Piperine | 1.684 | Phosphate crown | 1.51-1.56 |
| Quinidine | 1.700 | Barum silicate crown | 1.54-1.60 |
| Phosphorus | 2.224 | Boro-silicate flint | 1.55 |
| Realgar (artificial) | 2.549 | Borate flint | 1.55-1.68 |
| Diamond | 2.47 | Barium phosphate crown | 1.57-1.59 |
| Crown glass | 1.51 to 1.53 | Very heavy silicate flint | 1.96 |
| Plate glass | 1.516 | Glass of antimony | 2.216 |
| Flint | 1.54 to 1.62 | | |

(Carpenter abridged).

APPENDIX IX

TWENTY-FIVE COMMON FAULTS IN PHOTO-MICROGRAPHS: THEIR
CAUSE AND MEANS OF CURE

1. A shaded effect over *one* side of the print which is not observable on the other.

1. This is mostly due to the light being unequally spread over the surface. In other words, if in a *low* power photograph to the *lime not being central*. In a *medium* or high power one partly from that source, and also because the *auxiliary* condenser is *not* central. Perhaps, too, the substage condenser is out of centering.

2. A flat and dull appearance over the whole picture.

2. This may arise from several causes—*over*-exposure with *under*-development; or not enough bromide in developer. Fogging of the plate *before or during* development, which may give rise to the idea during development that that process has been carried far enough, and yet in reality is *not of sufficient duration*.

Light entering the camera during exposure, or whilst the slide is being drawn. See that the exposing shutter acts properly, and that the dark room is sound. Too much soda in the developer will cause much the same effect.

Under-exposure with prolonged development to gain density will often produce a dull picture, but then it is usually "chalky."

Unsuitable plates may cause this effect too; one developed with ammonia, if in excess; and this happens not unfrequently with isochromatic plates. Avoid ammonia in developer.

3. Definition good on one side of the picture, but poor on the other.

3. This may arise from the specimen not being flat, or the cover-glass uneven or bent. The objective may be out of centre (see page 74). The draw-tube may be out of centrality. The slip upon which the specimen is placed unequal in thickness. If with *low*-power work, the support S in Fig. 9, page 14, not at right angles with the lens; or the lens and camera not at right angles with the stage S. The lens may not be mounted *true* on the camera. The camera *back* which holds the dark slide may be out of square with the camera. The dark slide may itself be at fault. Try a piece of ground glass in the slide itself, and examine the picture attentively; the plate itself may be at fault by being thicker at one end than the other, but this is a mere possibility in the present day.

4. General definition at fault in the negative.

4. Bad focussing through ground glass not in register with dark slide, or fault in the actual focussing to commence with. If a hand focusser be used, it may not have been previously adjusted to the thickness of the ground glass (see page 55). A bad objective in which the chemical and visual foci may not be coincident: a visual achromatic used in the place of one corrected for photography: a lens employed which will not photograph correctly with a given colour-screen: a slight shake in the apparatus at the time of photographing—with very high-power work, a piece of the lime flying off during the exposure. The fine adjustment out of order jumping after operator has finished.

5. Definition only superficial; no depth of focus.

6. General "flatness" and lack of contrast especially seen when photographing bacteria or kindred objects.

7. Curiously elongated appearance of objects such as bacteria all in *one* direction.

8. White-line effect around hairs or around bacteria.

9. Blackened effect and increase in area of the shadows in diatoms.

10. General poorness of definition, with lack of detail in diatoms.

11. A circular loss of light around periphery of picture.

12. Dots of circular appearance with rings around them show on the negative, but cannot be *seen* through the microscope without great attention.

5. This may arise in *low*-power work from too large a diaphragm being used. In *medium* and *high* power work from too thick a specimen, or too high angled an objective—one with too great a numerical aperture. Shut Davis diaphragm a trifle, or close substage iris a little, or both. With very thick objects, photograph first with a low power with high N. A.—such as with an inch apo. N. A. '3, and subsequently enlarge the negative (page 30).

6. Wrong contrast screen employed. Underexposure or under-development, or both. Absence of critical light. Plate improperly sensitised for the special colour of screen.

7. This curious effect mostly arises from using a too freshly made specimen. The objects float in the Canada balsam, or the cover-glass slowly slides over the slip.

8. Always arises from closing the iris diaphragm too much—a modification of this effect arises from not "backing" the plate.

9. From iris being too closed—absence of "backing" on the plate.

10. The cover-glass adjustment may not be correct for the thickness of the cover-glass. This mostly occurs in high-power dry lenses— $\frac{1}{8}$ for example. If no cover-glass corrector to lens, draw out or push in the draw-tube (page 85).

11. In *low*-power work this arises from too small a condenser, or it is placed too far from slip. In *high*-power work the light is not actually critical, or the wrong condenser used.

12. This arises from dirt in the eye-piece. Turn the eye-piece round on its axis; they will move if it arises from this cause. Bubbles of a minute nature in the cover-glass or in the

13. Unequal illumination in the background, although the light is central and all other defects remedied.

14. Minute points *known* to exist in specimen cannot be well seen in photograph when using a given lens.

15. Negative generally thin.

16. Negative black looking and high lights choked.

17. When using "oblique light" too long an exposure becomes necessary.

18. *Definition* at fault when using oblique light and immersion condenser, which becomes worse and worse *the greater the obliquity*.

19. Unsatisfactory effect in definition with high-power work which cannot be accounted for by any of the previous remarks, especially noticeable as accompanied with roundness of field.

20. General fogginess of image on the ground glass.

Canada balsam. Clean the eye-piece with spirits of wine. Avoid touching the lacquer.

13. Unequal colouring of the Canada balsam. Place slide on white paper, and see if one part is not of a *deeper yellow than another*. Expose deeply and develop highly. Then, in printing, hold two feet from light, giving four times the exposure sufficient at one foot, shading the too thin portions whilst so doing with a card. Be careful when selecting specimens to avoid this nuisance.

14. The objective is probably of too low a N. A. The field is flooded, perhaps, with too much light. Close the substage iris a trifle. Too violent a contrast screen used. Plate not sufficiently "backed."

15. Under-exposure or under-development. If not too pronounced, intensify (page 126).

16. Too much developed—thin (page 124).

17. See if the beam from auxiliary condenser plays *directly* into the limited aperture in the iris. Shift the condenser until it does, and the light also if necessary. If using a mirror, try the concave side.

18. See that the oil connecting substage condenser has not dried up and "run off." This is nearly always the cause.

19. See that the substage condenser is central. Close iris to a pinhole, and lower the whole substage, and note if pinhole is central with the eye-piece employed. Occasionally this may be central with *one* eye-piece and *not* with another.

20. See if eye-piece is not "steaming" from condensed moisture on the front lens or the back one.

21. In low-power work; adopting all precautions explained, if the light falls off sensibly along the periphery of picture, although definition not so much impaired.

22. Absence of *blackness in the shadows*.

23. The clear portions of specimen are clouded and veiled in the print.

24. Small dots on diatoms or faint lines *imperfectly* shown.

25. Roundness of field.

21. Lens has not sufficient "covering power." Use one of longer focus, or having a wider angle.

22. Nearly always from a badly corrected objective; occasionally from "flooding" with too much light. Try contracting the cone a trifle by closing the iris.

23. Over-exposure in print, or objective badly corrected for colour. Try intensifying the negative. May be due to over-exposure.

24. Too low a N. A. in objective, or too much flooding of light. Badly corrected objective: bad centering of the apparatus somewhere.

25. Apochromats of the very highest order have this fault. Use a lower eye-piece and draw out camera to obtain necessary amplification. Always remember to use a low eye-piece (projection 6 is best), and lengthen camera whenever possible.

APPENDICES

20. In low-power work: adapting all procedures explained, if the light falls off sensibly along the periphery of picture. Although definition may be much impaired.

21. Lens has not sufficient "covering power." Use one of longer focus, or having a wider angle.

22. Aberrance of light due to the objective.

23. Nearly always from a badly corrected objective; occasionally from "flooding" with too much light. Try contracting the cone a little by closing the iris.

PLATE I

EXAMPLES OF LOW-POWER PHOTO-MICROGRAPHY

(The negatives and reproductions are untouched)

- FIG. 1. **Spinal Cord (Cat) Cervico-Medullary Region.** Photographed with Dallmeyer photo-micrographic rectilinear 1.75 inch focus at F/16 x 6
- FIG. 2. **Medulla Oblongata (Cat).** Photographed with Dallmeyer photo-micrographic rectilinear 1.75 inch focus at F/16 x 7
- FIG. 3. **Male Spider (Garden).** Photographed with Zeiss 50 mm. "Planar" at F/16 x 2
- FIG. 4. **Male Spider (Garden).** Photographed with Zeiss 50 mm. "Planar" at F/16 x 9
- FIG. 5. **Tortoise-shell Butterfly.** Photographed with a Petzval portrait lens, 3 inch focus at F/16 x 1½
- FIG. 6. **Ureter, Section of.** Photographed with an ordinary photo-micro-objective used on the camera. It shows purposely the unequal illumination produced by not properly centering the condenser before taking the photograph, and that the lens made for the small field of the microscope has not sufficient covering power and so is not suitable for camera use, as evidenced by the falling off of definition towards the periphery of the specimen. x 10
- FIG. 7. **Oesophagus, injected.** Photographed with Dallmeyer photo-micrographic rectilinear 1.75 inch focus at F/16 x 6

PLATE I
EXAMPLES OF LOW-POWER PHOTO-MICROGRAPHY

(The negatives and reproductions are untouched)



Fig. 1

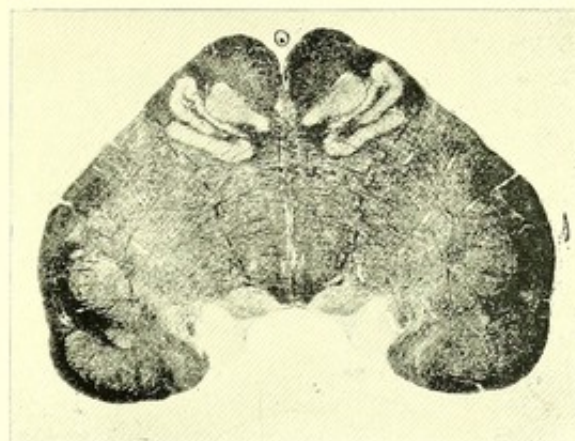

Fig. 2

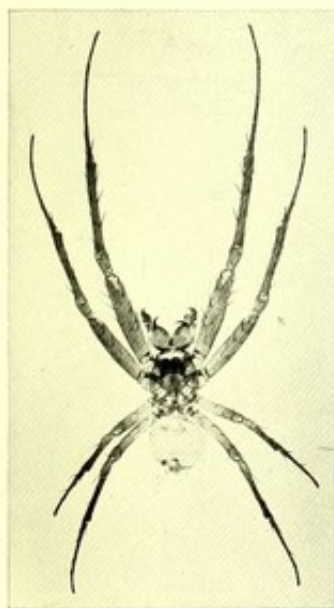

Fig. 3

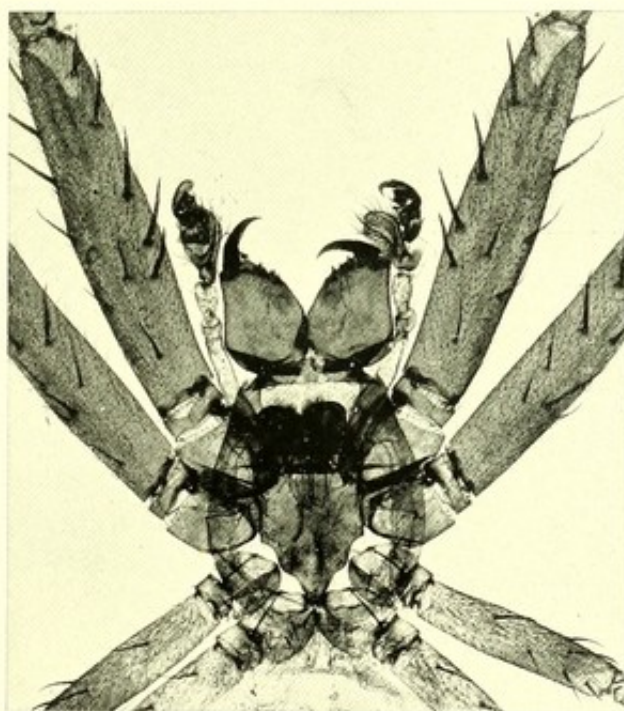

Fig. 4



Fig. 5



Fig 6



Fig. 7

PLATE II

EXAMPLES OF LOW-POWER PHOTO-MICROGRAPHY

(The negatives and reproductions are untouched)

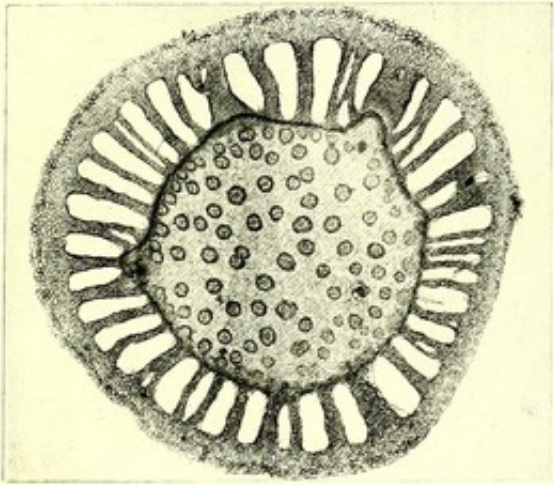

Fig. 1

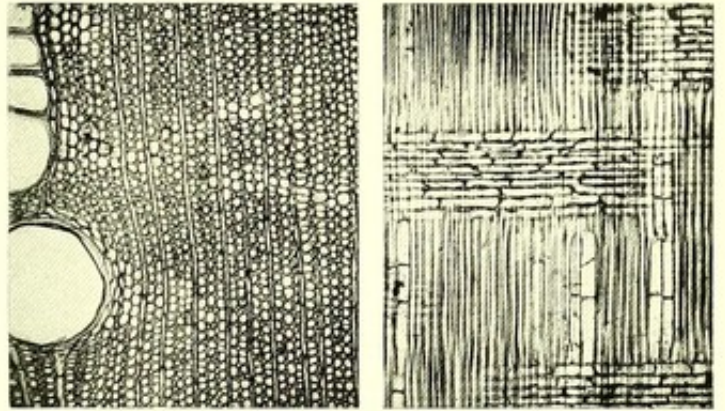

Fig. 2

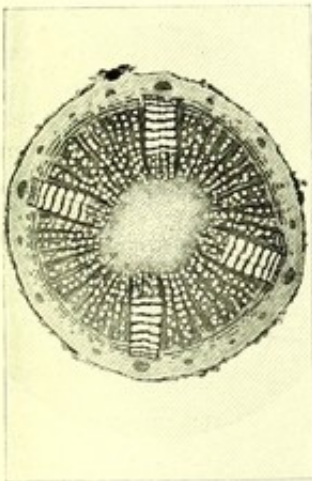

Fig. 3

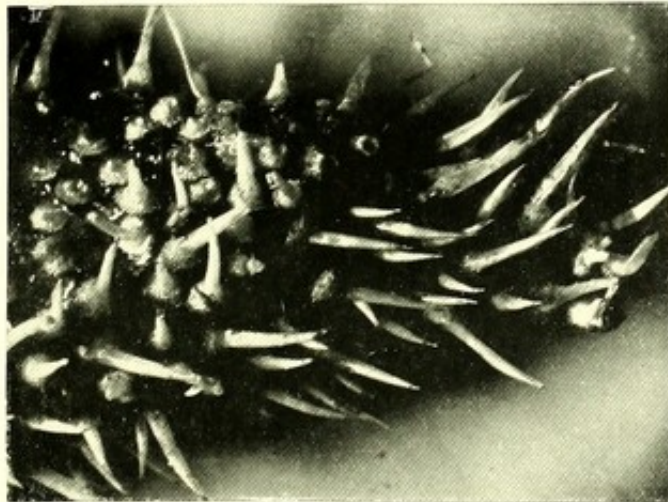

Fig. 4

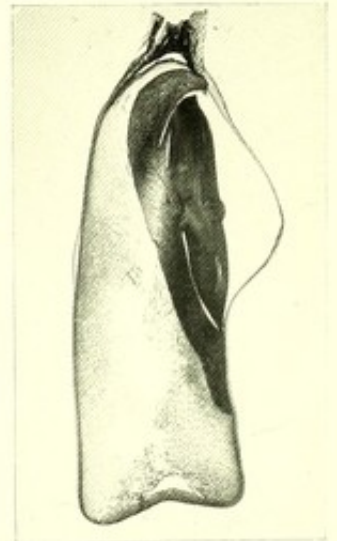

Fig. 5

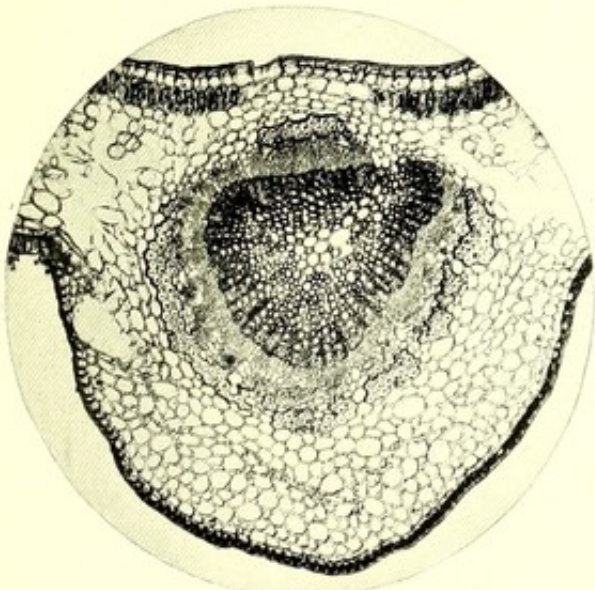

Fig. 6

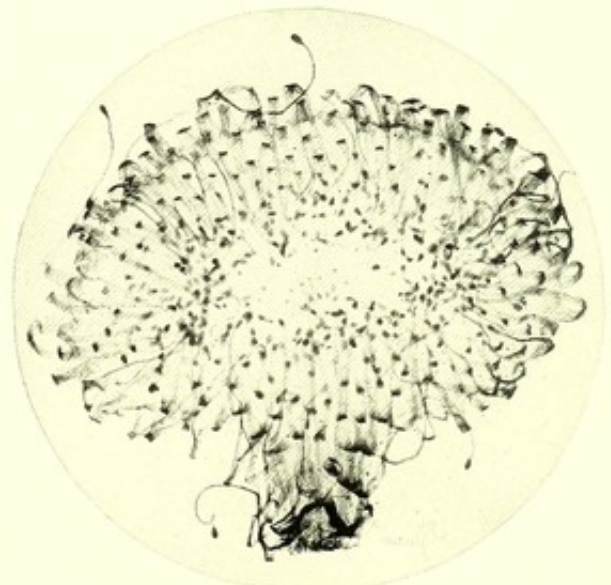

Fig. 7

PLATE III

EXAMPLES OF MEDIUM-POWER PHOTO-MICROGRAPHY

(The negatives and reproductions are untouched)

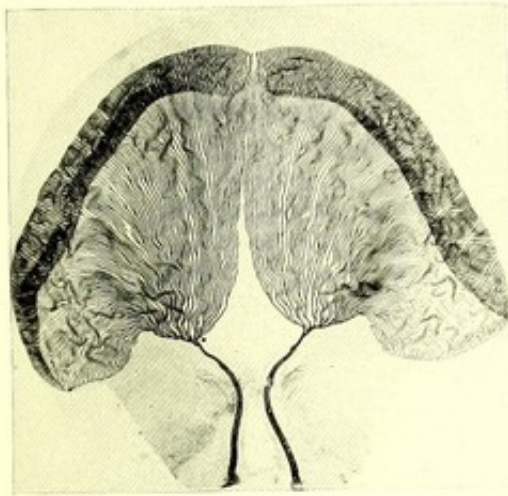

Fig. 1



Fig. 2

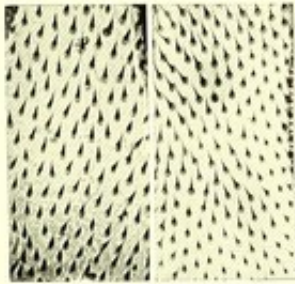

Fig. 3

Fig. 4

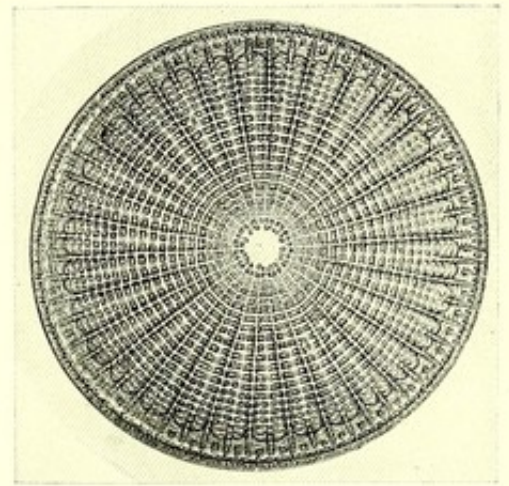

Fig. 5



Fig. 6



Fig. 7

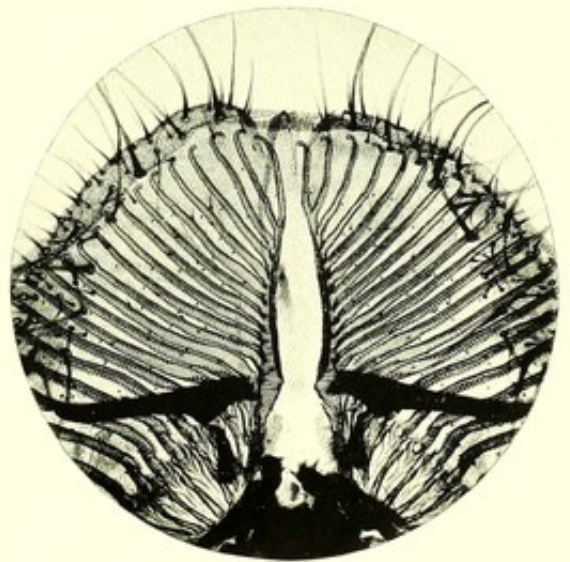

Fig. 8

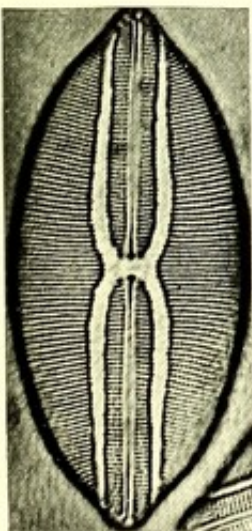

Fig. 10



Fig. 9

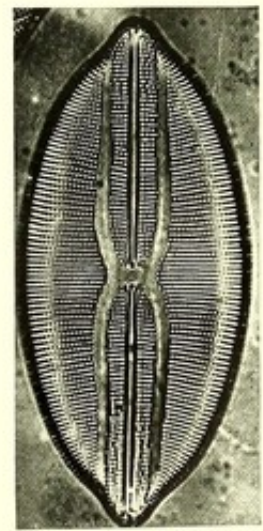

Fig. 11

PLATE IV
 EXAMPLES OF HIGH-POWER PHOTO-MICROGRAPHY
 (The negatives and reproductions are untouched)

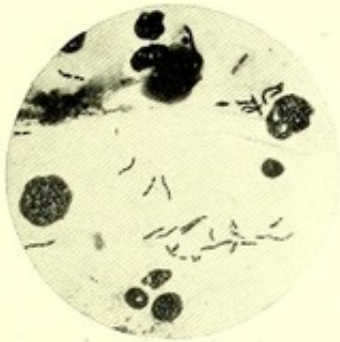

Fig. 1



Fig. 2



Fig. 3

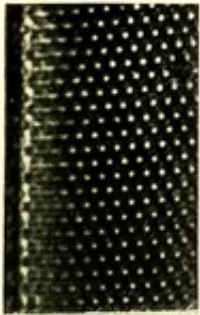

Fig. 5

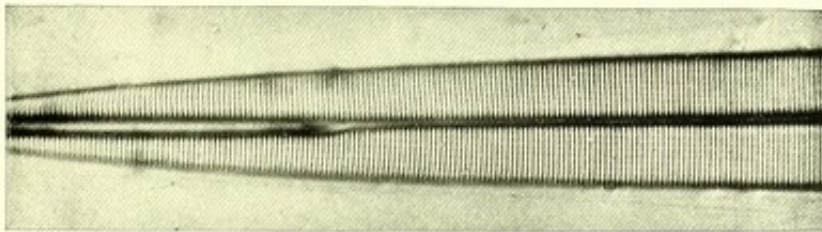

Fig. 4

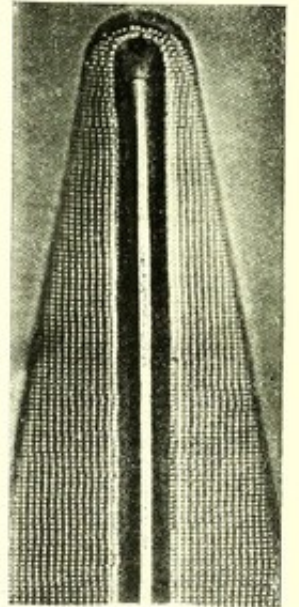

Fig. 8

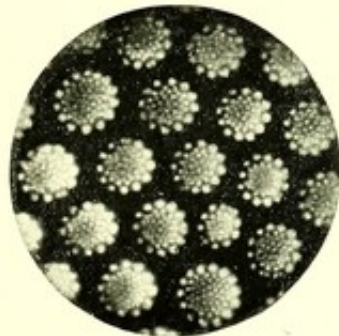
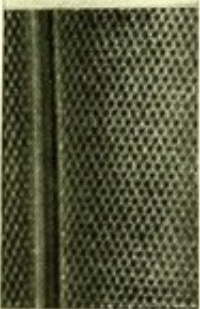

Fig. 6

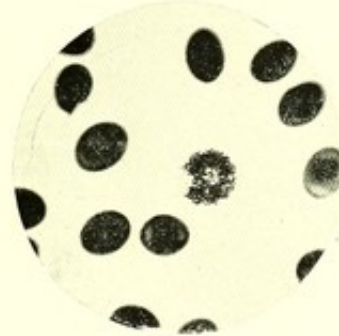

Fig. 7



Fig. 10

Blocks by A. E. DENT & CO.

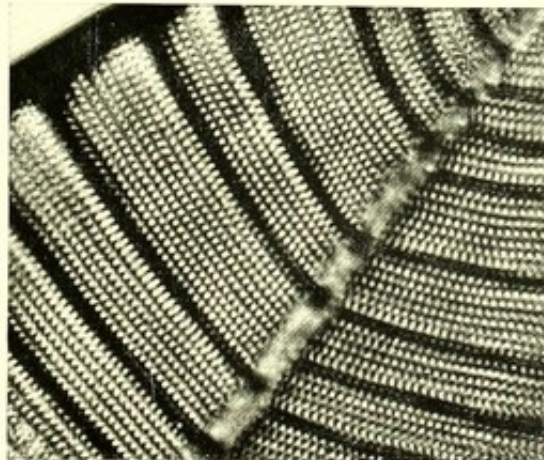

Fig. 9



Fig. 12

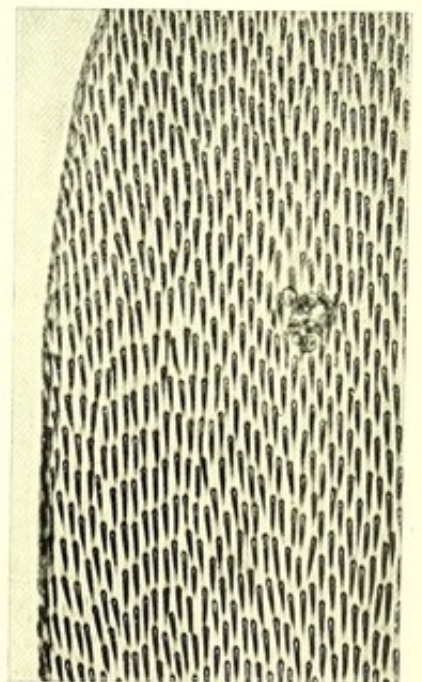

Fig. 11

E. & H. SPITTA, Photos.

PLATE V

(The negatives and reproductions are untouched)



Fig. 1



Fig. 2



Fig. 5

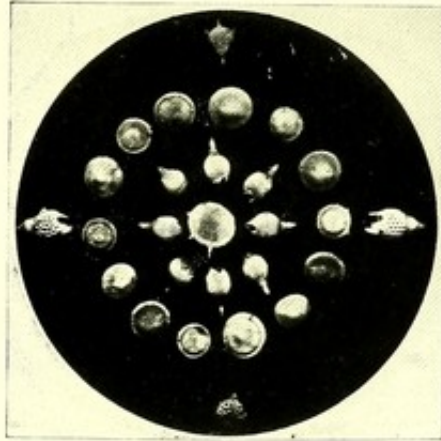

Fig. 6



Fig. 3



Fig. 4

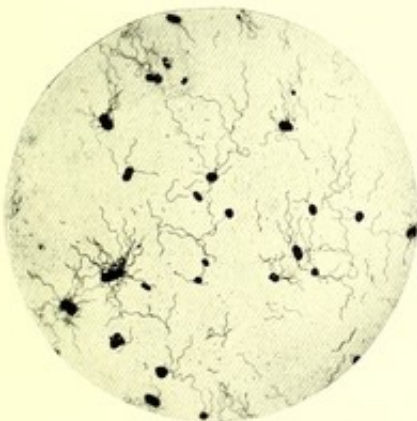

Fig. 7

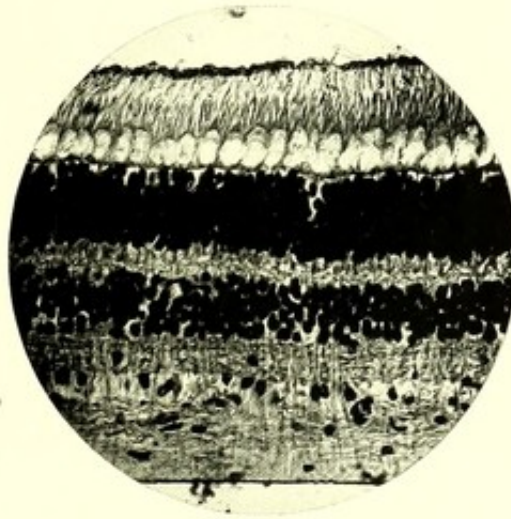

Fig. 11



Fig. 8



Fig. 9

Blocks by A. E. DENT & CO.

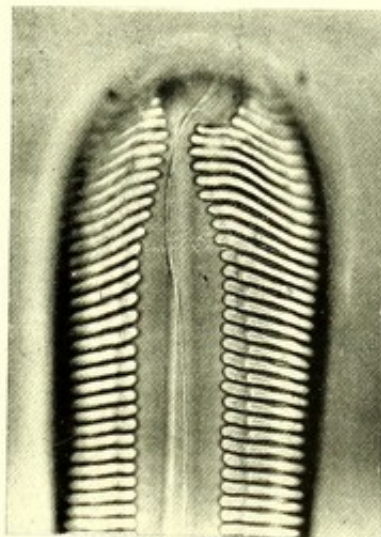

Fig. 12

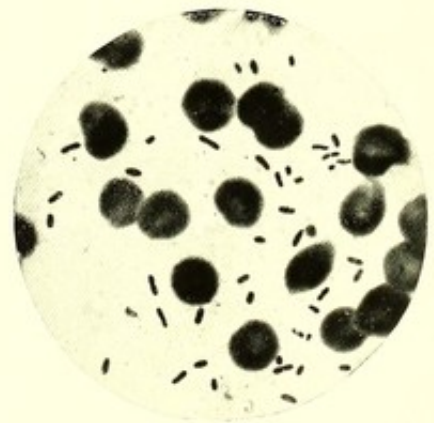

Fig. 10

E. & H. SPITTA, Photos.

Figs. 1, 2, 3, 4, 7, 8, 9, 10, are reproduced from "An Atlas of Bacteriology" by the kind permission of the Publishers

INDEX

A

- ACHROMATIC objectives, for visual purposes, and also those corrected for photography, 78, 79, 117
- Adjustment, cover-glass, 84
- Albumen prints, mistakes in making, 45
- Amphipleura pellucida, how to photograph, 140
- Angle, "critical," 83
"limiting," 83
- "Annular light," danger of misinterpreting results obtained by the use of, 94
for illuminating objects placed on microscope, 112
- "Antihalo" plates, their use in photo-micrography, 20
- Apertometer, by Zeiss, 88
- Aperture of condensers, *A Note on*, 89
numerical, what is it? 85
numerical, how obtained by apertometer, 88, 89
how obtained by method of Conrady for dry objectives, 90
- Apochromatics, table of penetrating power, 129
- Apochromatic objectives, 80, 116, 117
- Author's arrangement for producing annular light, 95
photo-micrographic stand and apparatus for medium and high power work, 54
arrangements for low-power work, 14, 24, 27
- Auxiliary condenser as arranged by author, 104
condenser, its position, 54, 104
condenser, how to centre, 105

- Auxiliary condenser, 104
condenser as arranged by Watson, 104
condenser, its use and objections discussed, 104
front, for use with camera in low-power photo-micrographs, 19

B

- BACKING plates in photo-micrography, 20
- Bacteria, photography of, 134, 143
the use of contrast screens to make good photographs, 145
- Baker's photo-micrographical stand, 49
microscope, Nelson model, 60
- Beard's jets for mixed gas, 5
gas-bottle regulators, 9
- Beck's model for photography, 61
objectives, 78
photo-micrographical table, 49
- Blow-through jet, 7
- Board of Trade and gas-cylinders, 8
- Brewster, Sir David, his view of use of substage condenser, 95
- Brin's oxygen works, 8, 137
cylinders the best that can be used, on account of the firm's many experiments for producing absolute safety, 8

C

- CAMERA and microscope, excluding light from their junction, 118

- Camera dimensions in low-power photo-micrography, 19, 25
- Centering auxiliary condenser, 105, 138
- Collodion slides, dry and wet, how to make, &c., 39
- Condenser, arrangements under, for introducing various coloured glasses, 102
- arrangements for reducing its aperture, 102
- auxiliary, mount by author, its position, 104
- auxiliary, arrangement by author, 104
- auxiliary, by Watson, 104
- by Beck, 98, 101
- by Conrady, 98, 101, 138
- Powell & Lealand, apochromatic N. A. 1'0, 97
- by Powell & Lealand, 97, 100, 138
- by Watson, 98
- by Zeiss, 97, 102
- definition in, 99
- for low-power photo-micrography, its uses, 15
- for use with 1-inch, 119
- for use with half-inch, 126
- for use with high-powers, 135 *et seq.*
- how to centre, 102, 103, 138
- leading points concerning, 96
- position of the rays coming from in low-power work, 15
- spherical aberration of, 97
- substage, 92
- substage Abbe chromatic, 92
- Cone, aplanatic, 97
- aplanatic, what is meant by the term, 97, 98, 99
- from *over*-corrected lens, 97
- from *under*-corrected, 97
- from *uncorrected* lens, 97
- of condenser, how to ascertain size of *aplanatic* cone, 98
- of light effect of bad correction, 99
- of light given by the substage condenser, 92
- Conrady, his formula for ascertaining the N. A. of dry objectives, 90
- condensers, 98, 101, 138
- objectives, 78
- Contrast glasses and screens, their utility discussed, 145
- contrast screens how made, 145, 146
- Coscinodiscus asteromphalus secondary markings, how to photograph, 137
- Cover-glass adjustment, 84, 85
- Covering-power in lenses, 18
- Critical angle, 83
- image, 98, 103
- "light," 98, 103, 130
- photography, 1, 109, 134
- Culture tubes, photography of, 26
- Cylinders for holding compressed gas 8,
- danger of using those made by inferior manufactures of bad steel, 8
- D
- DALLMEYER'S rectilinear for low-power photo-micrography, 18
- Dangers of using cylinders of bad steel, 8
- Dark ground illumination of objects placed on microscope, 112, 132
- room, testing of, 33
- Davis diaphragm, use of, with the one-inch, 121
- diaphragm, use of, with the half-inch, 127
- Depth of focus, 86, 129
- Developer, formula for negatives, 33
- for wet collodion plates, 40
- for lantern plates, 33, 37
- for dry collodion plates, 33, 39
- Developing bromide enlargements, 35
- Development, medium-power photo-micrography, 122
- of negatives for low-power photo-micrography, 32
- treatment of over-exposure, 122
- of negatives for high-power photo-micrography, 142
- Diaphragm used with "Planar" and Dallmeyer lenses in low-power photo-micrography, 22
- Diatoms, mounters of, 130
- Direct light for illuminating objects placed on microscope, 110
- Double oblique light, 113
- Drying negatives, 35
- E
- EDINBURGH model microscope for photo-micrography, 66
- Edwards's "Antihalo" and isochromatic plates, their use of in photo-micrography, 19, 20
- "snap-shot" plate, occasional use of, 139, 142

Electric light in photo-micrography, 2, 3
 Enlarging from primary negative where only one or two copies are wanted, 29, 30
 Equally illuminated field, the importance of, in photo-micrography, 21
 Exposure with Edwards's isochromatic backed plates and Edwards's "Antihalo" in low-power photo-micrography, 22
 for "snap-shot" plates, 142
 medium-power photo-micrography, 127
 shutter, author's, 107
 shutter by Watson, 108
 Eye-pieces, 90

F

FAULTS in albumenised prints, 45
 in photo-micrographs, 152
 in wet plates, 41
 Fine adjustment, how to clean in Zeiss models, 72
 adjustment illustrated, 70, 71
 adjustment in microscope, 70
 Firth, diatom mounter, 130
 Fixing solution for negatives and lantern plates, 34
 solution for wet collodion plates, 39
 Focal length of lenses in low-power photo-micrography formulæ, 22, 23
 Focussing in low-power photo-micrography, 17
 medium-power and critical photography, 120, 137
 Formula for ascertaining length of camera to be used for given lens in low-power work, 23
 for ascertaining magnification of object with given lens and camera length, 23
 for ascertaining N. A. of dry objectives—Conrady, 90
 used for developing Edwards's plates, 33
 for developing wet plates (collodion), 40
 for developing lantern slides, 33
 for developing Nikko prints, 33
 for intensifying gelatin plates, 126
 for intensifying wet plates, 41
 for thinning gelatin plates, 124, 125
 for toning silver prints, 44, 45
 for use of lenses in low-power work, 23
 Forrester's "effective backing" for use in photo-micrography, 20
 Fram model microscope for photo-micrography, 67

G

GAS-BOTTLE regulators, by Beard, 9
 gauges, 9
 Gas-bottles, Board of Trade regulations, &c., 8
 Gatrell, diatom mounter, 130
 Gauges for cylinders (Beard's), 9
 Glasses for contrast, their utility discussed, 145
 Gwyer mixed-gas jet, 5

H

HELIOSTATS, 11, 12
 High-power photo-micrography, 1, 134
 How to use the limelight, 6, 10
 to avoid accidents when using gas-cylinders, 8

I

ILLUMINANTS, 2
 Illuminating, different methods of, 130
 Illumination, dark ground for objects placed on microscope, 112, 132
 of objects by large cone, small cone, and hollow cone of light, 92-113
 of objects placed on the microscope, 110
 of opaque objects, 113, 132
 Immersion lenses, why they give so much more light, 84
 how to photograph with, 135 *et seq.*
 Incandescent gas in photo-micrography, 2
 Intensifying collodion plates, 41
 gelatin plates, 126
 Introduction to photo-micrography, 1

J

JETS, blow-through, 7
 mixed, 3, 4, 5, 6

L

LANTERN-SLIDES by dry collodion plates, 39
 by printing-out emulsion, 39
 exposure, 36
 faults, 37
 how to make, 36

Lantern-slides, yellowing of, 38
 wet collodion plates, 39

Law of Snell, 82

Leitz's objectives, 78

Lens, ordinary photographic, how to ascertain its N. A. with any diaphragm, 147

Lenses, dry, ascertaining N. A. by Conrady's method, 90
 for low-power photo-micrography, 16, 17, 18, 23
 for photo-micrography, 17, 18, 78, 79
 for photographing "culture" tubes, 27

Lieberkühn, use of, 132

Light, annular, author's means of obtaining, 95
 annular, danger of misinterpreting effects given by its use, 94
 annular, for illuminating objects placed on microscopes, 112
 "critical," 103
 different cones of, given by substage condenser, 92
 direct, for illumination of objects placed on microscope, 110
 monochromatic, 105, 113
 "double oblique," 113
 "oblique," danger of misinterpreting effects given by its use, 94
 "oblique," for illuminating objects placed on microscope, 110
 oblique, Zeiss method of producing on microscope, 111
 polarised, for illumination of object placed on microscope, 114
 refraction of, 81
 reflected, for illuminating objects placed on microscopes, 110

Lime, zirconium, by Zeiss, 11

Limelight in photo-micrography, 3

Limes, darkening of, by impurities of coal-gas, 137
 for limelight, 11

"Limiting" angle, 83

Lines to inch, &c., how to ascertain in a specimen, 148
 how to ascertain by photographic method, 149

Low-power work, author's arrangement, 14, 24, 27
 apparatus, dimensions, 25
 photo-micrography, 1, 13
 photo-micrography apparatus, use in, 13

Low-power photo-micrography, diagram of apparatus, 14

Lumière's plates for photo-micrography, 19

M

MAGNIFICATION different meaning of terms, areas, and diameters, 114
 given by different foci usually adopted, 116
 of delicate details how to ascertain, by micrometer, 148, 149
 of object placed on microscope, how to obtain, 116, 117
 how the same can be obtained with different eye-pieces, objectives, and camera lengths, 128
 obtained by different arrangements of apparatus, how to decide which is the best, 128

Mechanical stage, the, 75
 stages of different patterns, removable, 76

Medium power photo-micrographs, 1, 47, 109

"Memoranda" concerning high-power photo-micrography, 142

Metric measures, with their English equivalents, 150

Microscope and camera, excluding light from junction of, 118

Microscope, how to fix on photo-micrographical table, 118
 illumination of objects, placed thereon, 110

Mixed jets used in photo-micrography, 3
 jet, working directions, 6

Möller, diatom mounter, 130

Monochromatic light, 105, 113, 145
 screens, how made, 145, 146
 their utility discussed, 145

Movable substage, 77

N

NAVICULA LYRA, comparison of photographs with high and low apertures, 137
 how to photograph, 136
 rhomboides, how to photograph, 137
 spectabilis, how to photograph, 135

Negatives, drying of, 35

Nelson, model by Baker for photo-micrography, 60

- Newton's mixed-gas jet, 4
 Nikko paper, mounting of, 44
 polishing of, 43
 prints on, 42
 Note on aperture of condensers, 89
 of "exclamation" in Podura scale, 139
 Nottingham hard limes, 11
 Numerical aperture, how ascertained by Conrady's
 method, 90
 how obtained by use of apertometer, 88, 89
 N. A. discussed, 85
 of objectives, 86
 apertures, how compared with high, 87

O

- OBJECTIVES, achromatic, visual and photographic,
 78-79
 apochromatic, 80
 changers, 73
 changers, care in use of, 74
 dry and immersion, 81
 immersion, why they give so much more light,
 83, 84
 selection of, 77
 Objections to using inferior oxygen, 137
 Oblique light, for illuminating objects placed on
 microscope, 110
 "double," 113
 misinterpretation of results obtained thereby,
 94
 use of, 132
 Zeiss method of obtaining, 111
 Oculars, 90
 Oil light in photo-micrography, 2
 Opaque objects, their illumination for the micro-
 scope, 113, 132

P

- PARABOLIC reflector, use of, with low powers,
 133
 Paraboloid, 112
 Pathological specimens, the photography of, 32
 "Penetrating-power" of different apochromatics,
 table of, 129

- Periodic structures, how to determine their rate
 per inch, &c., in specimen when its ampli-
 fication is known, 149
 how to use a millimetre measure for ascer-
 taining the space in which a number of
 periodic structures can be counted *to the*
 inch, 149
 Petzval lenses, use of, in low-power work, 17
 Photograph, medium-power work, how to take,
 119
 Photographic apparatus for enlargement on bro-
 mide, 29
 for low applied power work, 14, 24, 37
 lenses of ordinary type, to photo-micrograph
 with, 17
 Photographs of bacteria, 143
 Photo-micrography, backing of plates, 20
 critical work, 1, 109, 134
 how to avoid tremulations of floor, 47
 introduction, 1
 medium-power apparatus, 48
 the microscopes used for, 59
 medium-power work, 1, 47, 109
 table—
 designed by author, 54
 by Baker, 49
 by Beck, 49
 by Swift, 51
 by Ross, 52
 by Watson, 52
 by Zeiss, 52
 Photo-micrograph, vertical apparatus by Watson,
 after Van Heurck, 56
 by Zeiss, 57
 "Planar" lenses for low power work, 18
 Pleurosigma angulatum, how to photograph, 138
 mathematical inquiry concerning details of
 image, 141
 Podura scale, how to photograph, 139
 Polarised light exposure, 133
 how to obtain, 114, 133
 table of substances which show well, 133
 Polyxenus lagurus, how to photograph, 134
 Positives, printing of, on paper, 41
 Powell & Lealand's apochromatic 140 condenser,
 100
 lenses, 135
 microscope for photography, 62
 Prints on albumen paper, 45

Printing on Nikko paper, 42
 "Printing-out" paper, 46
 Pringle's vertical apparatus, 131
 Projection eye-pieces, 91, 126

R

RECTILINEAR lens by Dallmeyer for photo-micrography, 18
 Reflected light for illuminating objects to be photographed, 110
 Refraction of light, 81
 Refractive indices, a table of, 151
 Regulators for cylinders, 9
 Reichert's objectives, 78
 Right and left handed screws to cylinders, 9
 "Ross-Planar" lenses in low-power photo-micrography, 18
 Ross's objectives, 78
 mixed-gas jet, 5
 model for photo-micrography, 63
 Ruby lamp for developing, 31

S

SCREENS, contrast, their utility discussed, 145
 monochromatic, how to make, 145, 146
 Selection of objectives, 77
 final remarks on, 80
 Sensitised plates for use in photo micrography, 19
 Silver prints, 44
 toning of, 44
 faults in, 45
 Snell's law, 82
 "Spot lens" arrangements by author, 95
 ordinary arrangement, 102
 Stops for placing under condenser to make "annular light," 95
 Substage condenser, 92-103, 138
 condenser, how to centre, 92, 102, 103, 138
 movable, 77
 Support for camera, &c., in low-power photo-micrography, special arrangement for, 23-26
 Surirella gemma, how to photograph, 139
 Swift's lenses, 78
 model for photo-micrography, 64
 photo-micrographical table, 51

T

TABLE for conversion of British and metric measures, 150
 of dimensions for author's low-power apparatus, 25
 of magnification of different apo-objectives, 116
 of names of substances which make good polariscope slides, 133
 of penetrating power of different apochromatic objectives, 129
 of refractive indices, 151
 showing how different combinations of objectives, eye-pieces, and camera lengths can produce same amplification of object, 128
 "Taking the photograph" in low-power photo-micrography, 20
 Test plate of Zeiss, 84
 Thinning gelatin plates, 124, 125
 Thum, diatom mounter, 130
 Toning silver prints, 44

U

UNSCRUPULOUS firms supplying oxygen in unannealed and untested cylinders, dangers of, 8
 Use of bad cylinders, insufficiently tested, danger of, 8
 of cheap oxygen deprecated, 137

V

VAN HEURCK's model for microscope, 65
 vertical photo-micrographical apparatus, 56, 131
 Varnish for wet and dry collodion slides, 40
 Vertical apparatus by Baker, Beck, Leitz, Reichert, Pringle, 131
 illuminator by Watson, Powell & Lealand, and Zeiss, 133

W

WATER bath, how to make, 28
 Watson's mount for auxiliary condenser, 104
 photo-micrographical table, 52
 Wenham's paraboloid, 112
 Wet collodion plates, how made, 39

Wet collodion plates, faults in, 41
plates, intensification of, 41
Working directions for mixed jets, 6
Wray's photo-achromatic lenses, 78, 79

Z

ZEISS apertometer, 88
apochromatic lenses, 135

Zeiss microscopes, how to clean the fine adjustment, 72
models for microscope to be used in photo-micrography, 68, 69
photo-micrographical horizontal table, 52
"Planar" lens in photo-micrography, 18
test plate, 84
vertical table, 57
Zirconium limes, 11



POWELL & LEALAND, Opticians.

New $\frac{1}{12}$ -in. Apochromatic Homogeneous Immersion 1.40 N. A.

Price £10, with Correction Collar, 30s. extra.

THIS OBJECTIVE IS A RAPID PHOTOGRAPHER.

NEW DRY APOCHROMATIC CONDENSER

Corrected for thickness of Slip, can be adapted to the Ordinary Mount.

This Condenser is the best for Photo-Micrography, and the only Perfectly Corrected one made. Numerical Aperture .98. Price, without Mount, £6.

170 EUSTON ROAD, LONDON, N.W.

CATALOGUES FREE ON APPLICATION.

BEARD'S REGULATORS

Are the most efficient and perfect for controlling compressed gasses.

The best light is produced by using them.

By having the Gauge attached to the Regulator, the Quantity of Gas in Cylinder can be Seen during Use.

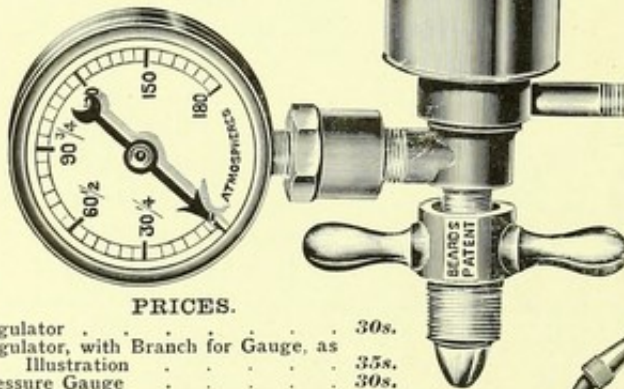

PRICES.

| | |
|--|------|
| Regulator | 30s. |
| Regulator, with Branch for Gauge, as Illustration | 35s. |
| Pressure Gauge | 30s. |

HARD LIMES.

*SPECIAL DURABILITY & BRILLIANCY
UNSURPASSED.*

Price 2s. 6d. per Dozen.

BEARD'S ECLIPSE SLIDE CARRIER.

Price 10s. 6d.

PERFECT FOR SINGLE LANTERN DISSOLVING.



The Easiest and Simplest Carrier for showing slides in a Single Lantern. Only one movement to produce the change, which is similar to dissolving. All the Slides are put in and taken out from one end. The Best Carrier extant.

IMPROVED HIGH-POWER MIXED JET.

Price 45s.



A MARVELLOUS LIGHT FOR
CINEMATOGRAPH.

R. R. BEARD, 10 Trafalgar Road, Old Kent Road, LONDON.

ur

AL. E. CONRADY

Manufacturing Optician

and

Scientific Instrument Maker

104 PARK STREET, CAMDEN TOWN
LONDON, N.W.

SPECIALTIES:

APLANATIC CONDENSERS

& MICROSCOPE-OBJECTIVES

OF THE HIGHEST QUALITY

C. BAKER

244 HIGH HOLBORN, LONDON

MICROSCOPES especially designed for Photography

FOR COMPLETE OUTFITS **PHOTOGRAPHIC**

See "APPARATUS FOR RECORDING OBSERVATIONS,"

98-99 CATALOGUE post free on application.

NEW SERIES OF "ACHROMATIC" OBJECTIVES.

SPECIMENS

Suitable for Photography.

FOR PARTICULARS OF OUR SPECIMEN
LENDING DEPARTMENT
see 98-99 Catalogue.

AGENT FOR



STAINS

and Reagents a Speciality.

The first consideration in Photo-
graphing Histological Specimens is
to have them suitably and vigour-
ously stained.

C. ZEISS, Microscopes, Apochromatic Objectives, and Planar Photo-
E. LEITZ, Microscopes and Objectives. [graphic Lenses.
C. REICHERT, Microscopes and Objectives.
DR. G. GRÜBLER'S Stains.

Awarded
39 Gold
and
other Medals.

W. Watson & Sons

[ESTABLISHED 1837]

Finest quality
workmanship.
Perfection in every
detail.

THE VAN HEURCK MICROSCOPE

GRAND MODEL

Manufactured solely by

W. WATSON & SONS.

Specially designed for Photo-Micrography and research with high powers. The stage *completely rotates* in any position, and the movements are controlled by two milled heads on one centre. The height to centre of Eyepiece, when the Instrument is set horizontally, is 10 inches. Fitted with Fine Adjustments of utmost sensitiveness and precision, not liable to derangement by wear. Has Rackwork Draw-tube to correct Objectives for thickness of cover glass. Can be used with either Continental or English Objectives. Has Fine Adjustment to Substage. The Stand is specially designed to afford the greatest possible convenience for manipulation. Price £28 10s.

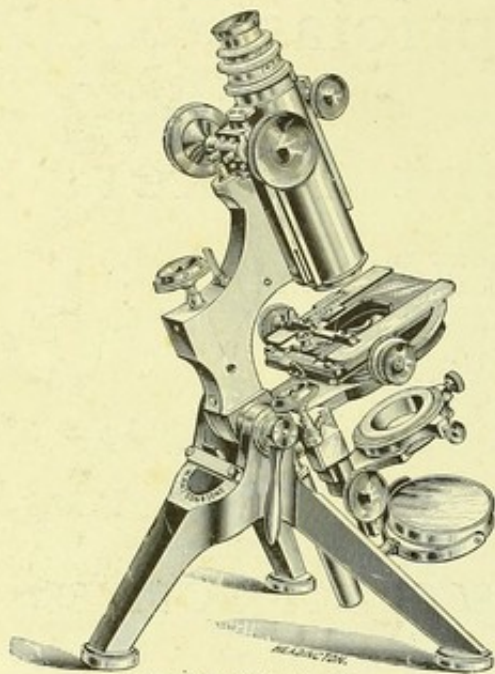

Grand Model Van Heurck Microscope.

WATSON & SONS' Edinburgh Student's Microscope.

This well-known and popular Instrument can now be had mounted on either the Tripod or Continental form of foot; also WATSON & SONS have recently designed and adapted a special form of Rackwork Draw-tube, and Fine Adjustment for Substage, rendering this Microscope more than ever suitable for work of the most precise nature. The quality and workmanship are of the finest possible, and it is unequalled for stability and precision of working parts by any other Students' or medium-sized Instrument. Prices from £3 10s.



"H" Tripod Edinburgh Student's Microscope, with mechanical movements to Stage, and compound Substage, as figured. Price £9 10s.

W. WATSON & SONS' "FRAM" MICROSCOPE.

A Highest-class Microscope at a very Moderate Cost.

COARSE ADJUSTMENT.—Watson's Diagonal Rackwork and Pinion. **FINE ADJUSTMENT.**—Watson's Lever form. All working parts fitted and finished by hand. Tripod foot with 7-inch spread. Stage measuring $3\frac{1}{2} \times 3\frac{1}{2}$, of the Nelson's Horseshoe pattern. Total height 11 inches. Body length 150 m/m.; with draw tube extended 250 m/m. Objectives of Watson's New Parachromatic Series constructed of Jena Glass; they are so mounted as to be approximately in focus when revolved a Nosepiece. Eyepieces, all working in the same focal plane; they have nickelled tubes and are of best quality.

Prices:

"FRAM" Microscope, as shown, with one Eyepiece, £4; Mahogany Case, 15s.

Set X.—"FRAM" Microscope, with one Eyepiece, two Objectives— $\frac{1}{2}$ inch and 1 inch, or $\frac{1}{2}$ inch or $\frac{3}{4}$ inch, complete in Mahogany Case, £6 15s.

Set XI.—Ditto, Ditto, with the addition of Abbe Illr., with Iris Diaphragm and an extra Eyepiece, in Mahogany Case, £8 5s.

Set XII.—FOR BACTERIOLOGY. Same as Set XI., with the addition of $\frac{1}{4}$ inch Oil Immersion Objective, and Watson's Dustproof Triple Nosepiece, complete in Mahogany Case, £14 5s.

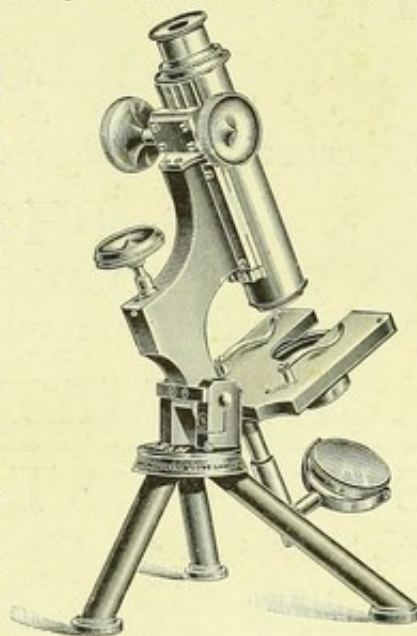

WATSONS' PHOTO-MICROGRAPHIC APPARATUS.

Sole Manufacturers of

THE STRINGER APPARATUS,
the most perfect condensing system extant.

THE PRINGLE VERTICAL
CAMERA
for Instantaneous work.

THE LABORATORY CAMERA

and

WATSONS' STUDENTS'
CAMERA,
price complete £4 15s.

WATSON'S Catalogue No. 2 contains particulars of all the above, and details concerning the various Microscopes, Objectives, Condensers, &c., &c., manufactured by W. & Sons.

Will be forwarded post free on application.

MICROSCOPIC OBJECTS.

WATSONS' Catalogue No. 3 is a Classified List representing a stock of 40,000 highest-class Specimens all of the highest class.

This will be forwarded post free on application to

W. WATSON & SONS,

313 HIGH HOLBORN, LONDON, W.C.

BRANCHES—Edinburgh: 16 Forrest Road. Melbourne, Australia: 78 Swanston Street.

DEPOTS—London (West End): Isenthal Potzler & Co., 85 Mortimer Street. Glasgow: W. W. Scott, 180 Sauchiehall Street.

Sheffield: H. Jasper Redfern, 55 Surrey Street. Manchester Agency: Woolley, Sons & Co., Victoria Bridge.

Carl Zeiss, Optical Works, Jena.

London Branch: 29 Margaret St., Regent St., W.

Telegrams:—"DIACTINIC, LONDON."

Manufacturers of Microscopes, Photo-Micrographic Apparatus, Photographic Objectives, Stereoscopic Binocular Field-Glasses, and Instruments for Optical and Physical Research, such as Refractometers, Comparators, &c.

NEW PHOTO-MICROGRAPHIC STAND.

This Stand has several being the short and wide and a new fine adjust-arranged and constructed impossible to injure it in by over-winding. The the body is extremely milled-heads by which it the value of the intervals metre. The wide, short much facilitates the use objectives, whether for projection on the screen. adapted for working with

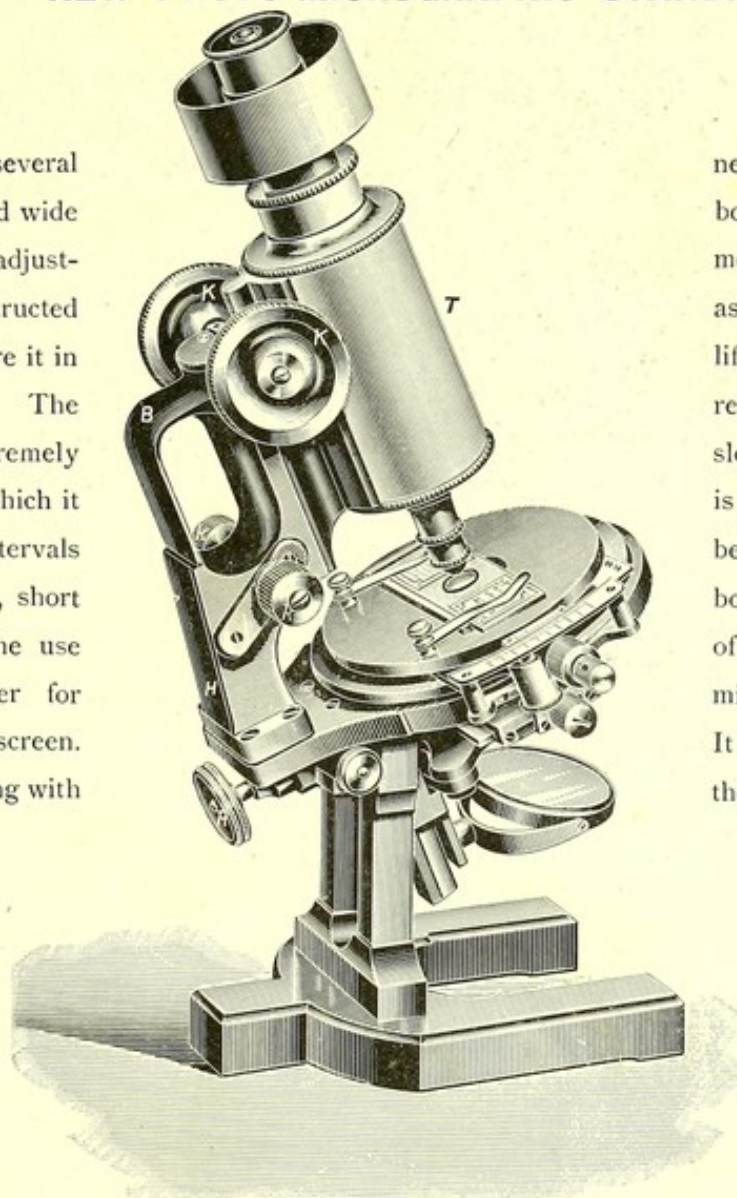

new features, the chief body-tube, 50 mm. diam., ment which has been so as to render it almost lifting the instrument, or resulting movement of slow, and one of the is moved is graduated, being 0.002 of a milli-body-tube of this stand of low-power long-focus micro-photography, or It is particularly well the Planars Nos. 1-4.

The following Catalogues will be sent free on application, stating which is required:

CATALOGUE OF MICROSCOPES, 31st Edition, 1898.

" " PHOTO-MICROGRAPHIC APPARATUS.

" " PHOTOGRAPHIC OBJECTIVES, 1897.

LIST OF PLANARS, PRICE LIST OF FIELD-GLASSES and REFRACTOMETERS, &c.

