

Architectural hygiene, or, Sanitary science as applied to buildings : a text-book for architects, surveyors, engineers, medical officers of health, sanitary inspectors and students / written and fully illustrated by Banister F. Fletcher and H. Phillips Fletcher.

Contributors

Fletcher, Banister, Sir, 1866-1953.

Fletcher, H. Phillips 1872-1916.

Publication/Creation

London : Fourdrinier, 1899.

Persistent URL

<https://wellcomecollection.org/works/h3xrz5va>

License and attribution

This work has been identified as being free of known restrictions under copyright law, including all related and neighbouring rights and is being made available under the Creative Commons, Public Domain Mark.

You can copy, modify, distribute and perform the work, even for commercial purposes, without asking permission.

**wellcome
collection**

Wellcome Collection
183 Euston Road
London NW1 2BE UK
T +44 (0)20 7611 8722
E library@wellcomecollection.org
<https://wellcomecollection.org>

ARCHITECTURAL
HYGIENE.

“The Builder”
Student's
Series.

3-



22502884046

ARCHITECTURAL HYGIENE;

OR,

ANITARY SCIENCE AS APPLIED TO BUILDINGS.

THIS BOOK IS DEDICATED
TO
THE LATE PROFESSOR BANISTER FLETCHER,
F.R.I.B.A., J.P., D.L., V.D., ETC.,
WHO DEVOTED MANY YEARS OF HIS LIFE TO THE ADVANCE-
MENT OF THE PRINCIPLES OF SANITARY SCIENCE
IN RELATION TO HIS PROFESSION,
BY HIS SONS,
WHO HEREBY DESIRE TO ACKNOWLEDGE
THEIR INDEBTEDNESS TO HIS
TEACHING AND INFLUENCE.

74.345

"The Builder" Student's Series.

ARCHITECTURAL HYGIENE;

OR,

Sanitary Science as Applied to Buildings.

A TEXT-BOOK FOR ARCHITECTS, SURVEYORS, ENGINEERS,
MEDICAL OFFICERS OF HEALTH, SANITARY
INSPECTORS, AND STUDENTS.

WRITTEN AND FULLY ILLUSTRATED

BY

BANISTER F. FLETCHER,

*Associate of the Royal Institute of British Architects ; Godwin Bursar ;
R.I.B.A. Medallist ; Late Vice-President of the Architectural
Association ; Lecturer on Architecture and Building
Construction, King's College, London ; Joint
Author, "A History of Architecture,"
&c., &c.,*

AND

H. PHILLIPS FLETCHER,

*Associate of the Royal Institute of British Architects ; Fellow of the
Surveyors' Institution ; Associate Member of the Institution
of Civil Engineers ; Director of the City Companies'
Trades Training School ; Lecturer on Quantity
Surveying, &c., King's College, London ;
Joint Author, "Fletcher on
Quantities," &c., &c.*

LONDON :

D. FOURDRINIER, "Builder" Office, 46, Catherine Street, W.C.

ALSO OF

WHITTAKER & CO., Paternoster Square, E.C.

1899.

LONDON:
PRINTED BY LOVE AND WYMAN, LIMITED.
GREAT QUEEN STREET, W.C.

WELLCOME LIBRARY
General Collections
M
14550

P R E F A C E .

SANITARY SCIENCE may be said to be the product of the nineteenth century, indeed of the Victorian era.

Although a considerable number of text books are published dealing with portions of the subject, the Authors feel that a concise yet complete text book treating the subject in all its branches, so far as it affects Architects, Surveyors, Engineers, Medical Officers of Health, Sanitary Inspectors, Plumbers, and Students generally, would be of real use. It is also hoped that such a work on this ever-advancing science, copiously illustrated, and brought up to date, should be of value to an increasing number of householders, who take an interest in the subject. These latter are finding out that soundness of drains and fittings, and also an intelligent interest in the fittings and finishing of a house, are indispensable to health.

The subject is treated *ab initio*, i.e., from the foundation of a building to its finishing and furnishing, and the application of modern methods of ventilation, lighting, and heating are discussed, so as to render the dwelling, when finished, a fit habitation for the occupant.

The subject of ventilation alone has been much neglected in the past ; even now, while local authorities have jurisdiction in regard to the erection of buildings,

they have no powers to require efficient ventilation, even in public buildings, such as theatres, music halls, and churches, &c.

Sanitary Science is one of the subjects in which candidates are examined at the Royal Institute of British Architects, the Surveyors' Institution, the Institution of Civil Engineers, the Institution of Municipal and County Engineers, the City Guilds of London Institute, the Sanitary Inspectors' Examination Board, and the Carpenters' Company, and the book is intended to be of use to those entering for these examinations.

The convenient system of tabulation has been used, and wherever possible an illustration has been given, so as to reduce the amount of printed matter and to enable the reader to understand at a glance what has been described.

The greater part of the contents of this book was written for, and appeared in, the Student's Column of *The Builder*.

BANISTER F. FLETCHER.
H. PHILLIPS FLETCHER.

29, NEW BRIDGE STREET,
LUDGATE CIRCUS, E.C

October, 1899.

CONTENTS

	PAGE
CHAPTER I.—INTRODUCTION	1
CHAPTER II.—SANITARY LEGISLATION	6
CHAPTER III.—THE SITE AND FOUNDATIONS	13
CHAPTER IV.—THE PLAN IN REGARD TO HEALTH AND CONVENIENCE	18
CHAPTER V.—SANITARY CONSTRUCTION	30
CHAPTER VI.—HOUSE DRAINAGE	41
CHAPTER VII.—DRAIN VENTILATION, INCLUDING SIPHONAGE AND TRAPS	58
CHAPTER VIII.—SANITARY FITTINGS	67
CHAPTER IX.—THE COLLECTION AND DISPOSAL OF REFUSE AND SEWAGE	91
CHAPTER X.—TYPICAL DRAINAGE PLANS	104
CHAPTER XI.—WATER SUPPLY AND POLLUTION	114
CHAPTER XII.—WATER SUPPLY FITTINGS, &c.	128
CHAPTER XIII.—VENTILATION... ..	137
CHAPTER XIV.—HEATING	159
CHAPTER XV.—VENTILATION AND HEATING SCHEMES	178
CHAPTER XVI.—LIGHTING	196
CHAPTER XVII.—SANITARY INSPECTION	213
CHAPTER XVIII.—SURVEYS AND REPORTS	225



Digitized by the Internet Archive
in 2015

<https://archive.org/details/b21782817>

ARCHITECTURAL HYGIENE;

OR,

Sanitary Science as applied to Buildings.

CHAPTER I.

INTRODUCTION.

IN the present work an attempt has been made to tabulate and co-ordinate the knowledge which exists in this most important of sciences.

The hygiene of architecture, it need scarcely be said, is one of the most important subjects which the architectural student has to study, for on its proper application in the practical execution of buildings erected under his supervision depends not only the health and well-being of his clients, but often their very existence. It is not too much to say that a building placed on a well-selected site, properly drained and executed with regard to its planning, and fitted up in accordance with the latest sanitary knowledge, reduces to a minimum the need for medical intrusion. In no other service is the intimate connection of cause and effect so painfully apparent; a badly constructed system of drainage is a certain cause of typhus, typhoid, and other diseases. It affects the health of the inmates in every particular.

The subject is presented in as simple a way as possible, and an endeavour will be made to include all that is necessary for the architect to know.

At present the literature on the subject is in a most chaotic state. There are ponderous tomes on particular branches, which are quite beyond the province of the practitioner, and there is no one treatise which combines the essential knowledge for practical use.

The subject is dealt with under the following divisions:—

- I. INTRODUCTION.
- II. SANITARY LEGISLATION.
- III. THE SITE AND FOUNDATIONS.
- IV. THE PLAN IN REGARD TO HEALTH AND CONVENIENCE.
- V. SANITARY CONSTRUCTION.
- VI. HOUSE DRAINAGE.
- VII. DRAIN VENTILATION, INCLUDING SIPHONAGE AND TRAPS.
- VIII. SANITARY FITTINGS.
- IX. COLLECTION AND DISPOSAL OF REFUSE AND SEWAGE.
- X. TYPICAL DRAINAGE PLANS.
- XI. WATER SUPPLY AND POLLUTION.
- XII. WATER SUPPLY FITTINGS, &c.
- XIII. VENTILATION.
- XIV. HEATING.
- XV. VENTILATION AND HEATING SCHEMES.
- XVI. LIGHTING.
- XVII. SANITARY INSPECTION.
- XVIII. SURVEYS AND REPORTS.

II. Sanitary Legislation.—Many Acts of Parliament contain clauses which refer to sanitation, and an endless array of authorities exist whose by-laws are to be followed. An attempt is made, therefore, to bring the more important provisions before the student in a simple manner, so that the principal regulations referring to sanitation can be seen at a glance.

III. The Site and Foundations.—The sites of buildings and proper provision for draining are then taken—a most important subject, and one which is often neglected.

IV. The Plan in Regard to Health and Convenience.—The position of the various rooms is considered in connection with the use and purpose for which each is required, as regards aspect and position.

V. Sanitary Construction.—The various materials in use in buildings, their special points and value, and their effective use in roofs, floors, and walls are dealt with in this

section. Special reference will be made to the exclusion of damp from walls, and the various methods in use in ordinary practice.

VI. House Drainage.—House drainage includes the laying of underground drains, the use of gullies, the comparative value of earthenware and iron pipes, and special points to be observed in the laying of drains so as to prevent blocking up. The inspection of drains by manholes will be also described and illustrated.

VII. Drain Ventilation, &c.—The important subject of drain ventilation and the prevention of siphonage in traps is dealt with, including their various forms.

VIII. Sanitary Fittings.—Next a chapter on sanitary fittings and traps which illustrates the different forms of closets and their traps, lavatories and their wastes, grease traps, baths, and water-waste preventers, &c., and the general use in buildings of all these fittings.

IX. Collection and Disposal of Refuse and Sewage.—Having thus planned the system of drainage we have to consider the important question of the disposal of sewage, including refuse collection, and to compare conservancy systems and water-carried systems, and the treatment of sewage.

X. Typical Drainage Plans.—Practical drainage plans for different types of buildings are given. These show the generally accepted methods of carrying the sewage and waste waters of the house.

XI. Water Supply and Pollution.—Then the important question of water supply and its pollution is undertaken, the effect of rainfall on a district, the advantages of a constant and intermittent supply.

XII. Water Supply Fittings, &c.—Connections to mains are discussed, and various fittings and taps, &c., are described.

XIII. Ventilation.—This includes the composition of air, the movement of air currents, the quantity of air required per person, and the impurities to be found in air. The best position for inlets and outlets in ventilation systems, and the division of the subject into natural and artificial systems.

XIV. **Heating.**—Under the section of Heating the comparative advantages of hot water in the high and low pressure systems, and of steam are discussed, and the general arrangement and form of heating apparatus. The subjects of ventilation, heating, and lighting are, of course, very much connected, and should be considered together.

XV. **Ventilation and Heating Schemes.**—Calculations for heating and ventilating various types of buildings are given, from the labourer's cottage to the crowded meeting hall.

XVI. **Lighting** is treated in conjunction with ventilation, but in this section the various kinds of illuminants are dealt with from a hygienic point of view.

XVII. **Sanitary Inspection.**—This section will be devoted to sanitary surveys and reports, a subject well within the ordinary practitioner's domain, and one by means of which the young architect may often tide over the early struggles of a professional career with profit to himself and friends. A model specification for the sanitary work of an ordinary small house is outlined, in which are incorporated the facts which have been laid down in previous chapters.

XVIII. **Surveys and Reports.**—Under this section model surveys and reports are given of different types of houses.

The importance of the above-mentioned subjects is fully recognised by the examinations which are held on it by the Royal Institute of British Architects, the Surveyors' Institution, the Institution of Municipal and County Engineers, the Sanitary Institute, and the Carpenters' Company, &c. It also forms part of the examination for the Diploma of Public Health held by the various Universities throughout the British Empire, so that these articles should appeal to a wide circle of readers.

Sanitary science is the bridge or link connecting the architectural and medical professions, and on it are to be found both architects and medical men. We need not discuss here to whom the work of making new buildings healthy and habitable in a hygienic sense really belongs, for it must be apparent that the architect should be solely responsible for it. He cannot delegate to anybody so

important a branch of his work, neither should he desire to. Architectural practice is interesting because of its variety, and while the architect may to-day be superintending the laying of drain-pipes and the formation of manholes, to-morrow he may be designing an altar frontal or a bishop's mitre.

While the architect should reserve to himself, as the *chief workman*, the planning and superintendence of everything connected with his buildings, he should, on the other hand, be ready to accept for inquiry the views of medical men on those subjects with which they are more familiar, and to make inquiries in an enlightened manner into all new ideas and inventions in regard to sanitation.

In sanitary science there is no lagging behind, no stopping on the forward march. In no other science that we know have such strides been made during the Victorian era. From Sir Edwin Chadwick onwards the progress has been uninterrupted, and in this volume an attempt is made to bring into one coherent treatise the whole subject as affecting architects whose privilege it is not only to superintend and re-plan the existing drainage of old buildings, but to see that in the structures which they erect the principles of hygiene may be carried out with as much success as the knowledge on the subject permits.

CHAPTER II.

SANITARY LEGISLATION.

THE principal enactments that refer to restrictions and regulations for buildings are as follows :—

- I. THE PUBLIC HEALTH ACT, 1875.
- II. THE VARIOUS FACTORY AND WORKSHOP ACTS.
- III. THE METROPOLIS MANAGEMENT ACT, 1855.
- IV. THE PUBLIC HEALTH (LONDON) ACT, 1891.
- V. THE LONDON BUILDING ACT, 1894.
- VI. LOCAL ACTS AFFECTING DIFFERENT DISTRICTS.

I.—THE PUBLIC HEALTH ACT, 1875,

Consolidated and amended the previous Acts relating to Public Health in England, but it does not refer to the Metropolis. Amongst the more important provisions of this Act the Sanitary Authorities must require a proper drain to every house, and this must be done before it is occupied; there must be an efficient closet or privy, and eaves, gutters, and rain-pipes may be ordered to be provided. No **cellar** may be used as a dwelling unless at least 7 ft. in height, 3 ft. of which is above the level of the street.

Under this same Act the Local Authorities are entitled to make by-laws; and the Local Government Board issued a set of **Model By-Laws** for the guidance of the Urban Sanitary Authorities. The by-laws made by the Authorities vary in different districts but are modelled on those brought out by the Board. The following are some of the principal provisions contained therein relating to buildings, &c.

1. **Refuse.**—The owner of any premises shall at least once a week remove the house refuse from such premises; and shall cleanse every earth closet which has a movable receptacle for faecal matter, and also every privy, once every week; and shall cleanse once in every three months every earth closet with a fixed receptacle.

2. **Foundations.**—Foundations are not to be made on putrid ground, and the whole site is to be covered with 6 in. of cement concrete, or to be asphalted, and a 3 in. clear space is to be left between the concrete and the underside of joists, ventilated with air-bricks.

3. **Low-lying Sites.**—Finished levels of low-lying sites to be made up with proper materials to a specified datum level.

4. **Walls.**—New buildings to have external walls of properly bonded bricks, stones, or other incombustible material; and hollow walls to be properly bonded. All walls to have proper footings projecting half the thickness of the wall on either side, and the depth to be two-thirds the thickness of the wall; external and party walls are also advised to be carried above the roof to lessen fire risks. Every wall is to have a proper damp course of impervious material. No wood plugs or bond timbers, &c., are to be put in party walls; and every girder is to have a proper template of its own full width, and every bressummer to have at least a 4-in. bearing at each end on a pier or story post.

5. **Chimneys.**—All chimneys to be built on a proper foundation or corbels, and the latter not to project more than the thickness of the wall. Unless flues be lined with fireproof piping, they are to be pargetted. Those used for trade to be surrounded with brickwork 9 in. thick for a distance of 10 ft. above the floor where the furnace is situated. Every chimney opening to have a proper arch and chimney bar. No chimney jamb to be less than 9 in. wide; no width to be less than $4\frac{1}{2}$ in. Flues are not to be carried up higher than six times the least width of chimney above the level of the highest point of the roof.

6. **Roofs.**—Roofs to be covered with incombustible materials, excepting as to frames and skylights, &c. Water from roofs to be discharged into gutters and stack-pipes.

7. **Open Spaces.**—No part of the front wall of any building except the porch, gate, &c., to be nearer than 24 ft. from the opposite side of the street, except a fence or wall not exceeding 7 ft. high. The minimum open space at the back of any building to be 150 square feet above the level of the ground; a closet and ashpit, however, may be above

this level. The depth of such space to be not less than 10 ft.

8. **Windows.**—Each room to have at least one window opening directly to the open air. Windows to be at least one-tenth of floor area and half of this must be made to open. A habitable room without a fireplace to be ventilated by an opening carried into the open air not less than 100 square inches in area.

9. **Drainage.**—The subsoil is to be drained if necessary. The lowest story to be above the level of the sewer. Drain pipes are not to be less than 4 in. in diameter, and to be laid on concrete with a proper fall and with water-tight joints; if they are laid under a building they must be bedded in concrete; no right-angled junctions may be used, and all drains must be properly trapped from the sewer. A **sewer**, as distinct from a **drain**, is that which contains branches from more than one house, and is made by (or acquiesced in by) the Local Authority. The importance of this distinction lies in the fact of the responsibility of the occupier of a house for the drain and of the Local Authority for the sewer. The house drain is to have two untrapped openings for ventilation, one at the lowest end and one at the highest. If one water-closet on the ground floor is not more than 10 ft. from the trap there is no need to ventilate the latter. No ventilation inlet to a drain is to be within a building. No trap is to be placed between a soil pipe and a drain pipe. Waste pipes are to discharge into the open air 18 in. away from the grating.

10. **Closets and Privies.**—One wall of every closet must be external, and must have an external window. The water-closet water supply must have a separate cistern or flushing apparatus from the house supply. The water-closet must not have container or D-trap. Earth closets to be outside dwelling houses and to have dry earth receptacles. Fixed receptacles to be easily accessible for cleansing and not larger than 40 cubic feet, and not to receive rain or waste water, and to be above the level of the ground (movable receptacles may not contain more than 2 cubic feet); privies to be 6 ft. from any building and 40 ft. from any well or spring, and to have means of access without

carrying the soil through the building, those with fixed receptacles not to contain more than 8 cubic feet, and no part to communicate with any part of a drain.

11. **Ashpits.**—No ashpit is to be within 6 ft. of a building, or 30 ft. of a well, and is not to contain more than 6 cubic feet. It should be constructed of brick or stone, and be 3 in. above the level of the ground and have an impervious floor. It must not communicate with the drain.

12. **Cesspools.**—Cesspools should not be within 50 ft. of a building or 80 ft. of any well or spring; they should have access for cleaning without passing through any building, and must not be connected with any drain. They should be built of 9 in. brickwork in cement, and rendered inside with cement, puddled all round with clay, and properly domed over and ventilated.

13. **Notice.**—Plans for new buildings or drainage works should be submitted to the Local Authorities, with descriptions of the materials, &c., to be used, and the sizes, depths, and inclinations should be figured thereon and the method of ventilation described; and the house should be certified before being occupied. All work done in contravention of by-laws to be removed, altered, or pulled down.

II.—THE VARIOUS FACTORY AND WORKSHOP ACTS.

These Acts are too numerous even to mention. They regulate the sanitary conditions of such premises as their titles imply, and give power to the Home Secretary to enforce special rules for the several kinds of manufacture. They require an air space of at least 250 cubic feet per head, and provide for efficient ventilation of these premises.

We will now deal briefly with the principal acts affecting the Metropolis only.

III.—THE METROPOLIS MANAGEMENT ACT, 1855.

Under this Act no drains are to be made except to the satisfaction of the Vestry or District Board, and the latter Authorities are empowered to inspect existing drains, privies, and cesspools, and to order the amendment of the

same. In case of an alteration to a building which will temporarily affect the footway, a proper hoarding must be erected and a licence for the same must be obtained from the Local Authority.

IV.—THE PUBLIC HEALTH (LONDON) ACT, 1891.

This Act includes the most important provisions of the Public Health Acts and Infectious Diseases Acts with many important additions. It prohibits the establishment anew of offensive trades, requires the licensing of cow-houses and slaughter-houses, demands that furnaces and steam vessels do consume their own smoke, provides for the cleansing of bakehouses, and provides for the inspection and regulation of dairies. The *London County Council* are bound to make by-laws with regard to :—

- i. The removal and disposal of refuse.
- ii. Water-closets, earth-closets, ash-pits, cesspools, &c., and the proper accessories thereof in new or old buildings.

The *Sanitary Authorities* must make by-laws with respect to :—

- (a) The efficiency of flush to water closets.
- (b) The freedom from pollution of tanks and receptacles of drinking water.

The *Sanitary Authorities* have also to observe and enforce the by-laws made by the London County Council.

The **London County Council By-Laws** contain the following modifications of the *Model By-Laws* previously referred to :—

1. **Refuse.**—Where daily removal is inaugurated the householder must deposit refuse in a movable receptacle on the kerbstone.

2. **Closets.**—There must be a window at least 2 ft. square in the external wall. A closet may not be approached directly from any room used for human habitation. The pipes and unions connecting any water-closet with flushing apparatus to be at least $1\frac{1}{4}$ in. internal diameter. If more than one water-closet be fixed to a soil pipe the traps of such water-closets to have anti-siphonage pipes of not less

than 2 in. internal diameter; such a pipe not to be connected to the soil pipe till it is carried above the topmost water-closet.

3. **Soil Pipes.**—All soil pipes to new buildings must be fixed outside such buildings, and this must be done, if possible, when refitting a soil pipe to an existing building. When such pipe is carried within any building, it must be of drawn lead or of heavy cast iron of specified weight, and with caulked lead joints. No soil pipe to be of less diameter than $3\frac{1}{2}$ in., and it must be carried up undiminished in diameter to the highest part of the roof, and must be 3 ft. higher than, and not within 20 ft. of, any window. The connection of all lead and iron pipes and traps must be made with a brass thimble with a wiped or overcast joint and caulked with molten lead to the soil pipe or drain. No waste pipe (except that from a urinal) to be directly connected with any soil pipe.

4. **Cesspools.**—Any cesspool must be at least 100 ft. distant from any dwelling, and it must be cleaned out every three months.

V.—THE LONDON BUILDING ACT, 1894.

This Act consolidated and amended the enactments relating to buildings in London. The following modifications of the Model By-Laws are important:—

1. **Low-lying Sites.**—No building to be erected on a site which is below Trinity high-water mark (*i.e.* 12 ft. 6 in. above Ordnance datum), and which cannot be drained by gravity into an existing sewer.

2. **Roofs.**—Means of access must be provided to the roof. The slopes of various roofs are regulated. Not more than two stories allowed in the roof of domestic buildings. A story above 60 ft. from street level and made in the roof, shall be of incombustible material.

3. **Open Spaces.**—The angle of $63\frac{1}{2}$ deg. is drawn from the rear boundary at the same level as the front pavement, and no part of a new domestic building is allowed to project beyond such line. With respect to domestic buildings to be erected in a street laid out before the commencement

of the Act, the angle of $63\frac{1}{2}$ deg. must be taken from the rear boundary, but may start 16ft. above the front pavement level. The front wall of a building not to be nearer than 20 ft. from the centre of the roadway.

4. **Height of Buildings.**—No new building to be of a greater height than 80 ft., and in streets laid out since August 7, 1862, no new building to exceed in height the distance from its front wall to that of the building opposite.

5. **Habitable Rooms.**—Every room to be at least 8 ft. 6 in. from floor to ceiling, except those in the roof, which must be at least 8 ft. high, but in the latter case such height need not be more than half the area of the room. If a room is over a stable the floor is to be pugged 3 in. deep, and the undersides of joists are to be ceiled with lath and plaster.

6. **Hard Woods.**—Oak, teak, and other hard woods are recognised as fire-resisting materials when they are 2 in. thick.

7. **Separation of Buildings.**—Every building over ten squares in area and used partly for trade or manufacture, and partly as a dwelling-house, the former is to be divided from the latter by fire-resisting structures.

8. **Flats, &c.**—In buildings constructed to be used by more than two families, the staircases to be ventilated on every story, directly into the external air.

VI.—LOCAL ACTS AFFECTING DIFFERENT DISTRICTS.

These Acts relate principally to the larger towns, and are framed to suit their various requirements.

They do not, as a rule, relate to buildings, but give special powers to Authorities for public works, sewerage, and water-supply, &c.

CHAPTER III.

THE SITE AND FOUNDATIONS.

THE importance of a site which possesses healthy conditions is, of course, apparent, for no amount of care in the construction of a building will avail if the situation of the house itself is unhealthy. In many cases, of course, the architect is not consulted, for it is obvious that in towns and many other places the building must be placed in some particular spot, whether it be at the top or bottom of a hill, &c. Selection is not possible in such cases, but the best must be made of the unavoidable circumstances of each case.

However, in the country, with an unlimited number of positions available, it is one of the first duties of the architect to select a site which shall be healthy.

This selection must depend on the variety of known circumstances, each of which should be carefully weighed. One of the greatest factors is the climate, which includes the consideration of temperature, rainfall, moisture of soil, and the nature and prevalence of winds. The healthiness of the external air depends largely on the openness of the site, the condition and nature of subsoil, including the vegetation and sources of contamination in the immediate vicinity.

Now, as has been pointed out, while the architect cannot alter those general climatic conditions of a country which are due to its position on the globe, and the vicinity of seas or continents, yet he may modify the conditions and temperature of the soil and diminish the atmospheric damp by drainage, and he may alter the moisture and temperature of the air by planting or removing trees. He may thus produce changes in the immediate surroundings of a locality.

All authorities agree that the condition which principally

governs the healthiness of a soil is the relation which the **ground air** (*i.e.*, air in the soil) bears to the ground water.

The moisture in the soil (*i.e.*, ground water) depends mainly upon the amount of rainfall, which varies in different parts of the country

The principal evil to guard against is the damp caused by the evaporation of the moisture in the soil, and this is bound to arise unless the level of the ground water is kept sufficiently below the surface of the ground, for the lower the water is in the soil, the less the evaporation and the warmer the adjacent air.

Now this evaporation lowers the temperature of the air surrounding the building and is therefore injurious. To remedy this, what is known as subsoil or under-draining is resorted to; which, by facilitating the passage of the water from the surface into the ground beneath, reduces the amount of the evaporation. Many diseases appear to be derived from dampness, amongst which may be mentioned phthisis (consumption); so that it is evident great care must be taken to keep down the ground damp by under-draining. Dampness of soil is also favourable to all affections of the respiratory system, such as bronchitis and pneumonia (including measles and whooping-cough), while it is generally admitted that damp and cold soils are conducive to rheumatism, neuralgia, and catarrhs.

This under-draining is effected by means of unglazed agricultural drain-pipes, butted against each other, and placed about 3 ft. 6 in. below the ground with a fall to a stream or river, so that the ground water cannot rise higher than 3 ft. 6 in. below the surface of the ground. Some authorities hold that ground water should not be allowed higher than 5 ft., but this appears excessive. The lines of pipes are placed from 3 ft. to 6 ft. apart, according to the nature of the soil, and are not jointed in any way. In free open soils, such as sand, a single drain will lower the ground water for a large area, whereas, in a stiff clay soil numerous drains are necessary. These drains, it need hardly be said, should be entirely independent of any drains used for carrying sewage. Drained and undrained sites have been tested by various authorities, and Sir Douglas Galton found that a

drained field would have a temperature as much as 6 deg. or 7 deg. Fahr. higher than an adjacent undrained field, for the following reason, viz., that to convert water into vapour 960 deg. (Fahr.) of heat is absorbed from its vicinity—thus, each cubic foot of water evaporated lowers the temperature of about 3,000,000 cubic feet of air 1 deg.

Dr. Parkes has prepared tables giving his opinion of the various soils used for building purposes in their order of fitness, to which the student is referred. We must here content ourselves with a few notes on the more ordinary soils :—

1. **Clay Soils** are generally regarded as bad, because they are impervious, hold the surface water, and are, unless carefully drained, damp, and give off unwholesome vapours in dry weather. However, houses have to be built on clay soils, and, provided they are properly drained, they can be made at least unobjectionable, although clay, being a good conductor, is always comparatively cold.

Porous soils are, however, often objectionable, because there may be an impervious stratum beneath which holds the water as in a basin, hence the term “London basin.”

2. **Gravel**, free from loam and with a pervious subsoil, is generally considered the best for building purposes, as it permits of the surface water rapidly draining away, and also of a good circulation of ground air varying with the atmospheric pressure.

3. **Marshy Soils**, including muddy sea-beaches or river banks, are unhealthy and hazardous to health, and statistics show that they are often responsible for malarial and other affections.

4. **Made Ground**, *i.e.*, ground which has been used as a dust and refuse shoot, and frequently found on the outskirts of towns and in the suburbs is, of course, bad and unhealthy to build upon.

5. **Chalk** is generally considered to be healthy if permeable and free from clay, but many chalks are impermeable and therefore damp and cold.

Having touched on the various soils, it remains just to treat of the **position** of the site, having regard to health. Sir Douglas Galton states that :—

1. Ground at the foot of a slope or in deep valleys which receives drainage from higher levels should be avoided, as it predisposes its occupants, even in temperate climates, to epidemic diseases.

2. High positions exposed to winds blowing over low marshy ground, although some distance away, are in certain climates unsafe, because of the liability to fevers. Indeed, Galton states that a site near a marsh, especially if protected by a screen of wood, is often safer than an elevated position to leeward and some distance off.

In advising a client as to the **suitability of a site for building purposes**, the architect should bear in mind the following points, which have been put in tabulated form for ease of reference:—

1. The local climate should be healthy.
2. The soil should be dry and porous.
3. The ground should fall in all directions to facilitate drainage. If possible a position on a steep slope should be avoided, as high ground near a building stagnates the air. This was proved very conclusively in the soldiers' huts at Balaclava. In those which were placed near a steep slope of earth, a much higher mortality occurred, compared with huts standing free.

4. There should be a free circulation of air in the district, and muddy creeks and ditches, undrained or marshy ground, should not be close to the house, or so that prevailing winds would blow the damp exhalations over the site.

5. The site, if exposed, should be protected from the north and east by the shelter of trees, &c., at a sufficient distance however not to cause stagnation of air or dampness. A general rule is that trees should not be nearer to a house than their own height.

6. The healthiness may be further tested by the rate of mortality of the district; although, if a health-resort, notice should be taken of its disease-curing properties.

7. The architect would be also careful to avoid the proximity of such unpleasant places as a sewage farm or soap works, brick kilns, cement works, and limekilns (which emit carbonic acid, &c.), slaughter-houses, refuse depôts, and stagnant ponds, all of which are unpleasant and

unhealthy, and a cemetery also has a very depressing effect on many people, and according to Dr. Whitelegge there is evidence of increased sickness and mortality among persons residing close to crowded graveyards, the air of which contains an excess of carbonic acid.

Public houses and schools are noisy, and often have a bad effect on the nerves of delicate people.

8. Lastly, the architect should ascertain the condition of the drainage in the district, whether it is on modern principles, with good fall, properly ventilated; with no back flow from high tides; and also obtain particulars of the outflow and the treatment of the sewage. If in the country, and there is no main drainage, a cesspool must be used; note if there is a convenient position for this, sufficiently far from the water supply.

The site having been selected, it must, further, be properly drained, if necessary, by agricultural drain pipes, as indicated previously, so as to keep the subsoil water below 3 ft. 6 in. from the surface. In the majority of cases, the site occupied by the building should also be covered with 6 in. of Portland cement concrete, with 1 in. cement-floated surface; this is necessary in order to keep down the ground air, which is charged with carbonic acid and other impurities which the water tends to force up. The Model By-Laws of the Local Government Board provide for this, and it has been demonstrated that families have often been more or less poisoned by vapours drawn through the ground by the warm air into the interiors of houses and cottages.

CHAPTER IV.

THE PLAN IN REGARD TO HEALTH AND CONVENIENCE.

THE **Plan** of a building must depend, of course, to some extent upon the site, and only general principles can be laid down which will serve to indicate those points that should be aimed at. The first principle we must observe is that the sun should enter every living room at some period of the day; the sun is as important to the air in a room as water is to the human body, and no room can be considered healthy which is not periodically disinfected by the sun's rays. It is, indeed, generally an easy matter to ensure this, and even old and badly planned houses can often be made healthy by the judicious insertion of bay windows, so that the occupants may enjoy the sun's rays either in the early morning or late afternoon.

In fact we have made it a principle to put in a small "sun-window" where possible, so that the sun's rays may, if desired, be obtained at some portion of the day. Although not essential in the summer, in the winter it adds much to the cheeriness of the house, and affects in no small degree the health and spirits of the inmates.

Daylight.—A sufficient and abundant supply of daylight should be provided for every room. The exact amount varies with regard to any obstruction which may be in front of the house. Gwilt's rule that in a square room 1 ft. super of glass should be provided for every 100 cubic ft. of air space in the room, would seem to be enough in the open country with unobstructed views. In towns, however, this should at least be increased to 1 ft. super for every 80 cubic ft. Another rule, propounded by Robert Morris in his "Lectures on Architecture," is to find the cubical contents of the apartment, and then find the square root of the result, which represents the superficial area of the window. This gives a much larger amount of lighting than

Gwilt proposes. The objection to windows being of excessive size is that they make the room so warm in summer and cold in winter.

Windows.—There is, moreover, a great deal to be done in the disposition of the windows. A pier in the centre of the wall of a room casts a shadow across the centre, which is objectionable, and an odd number of windows is to be preferred. No dark corners for the accumulation of dirt should be allowed. “Out of sight, out of mind,” is a saying which, in all matters of sanitary planning, should be well remembered.

Corridors.—Corridors should be well lighted and ventilated from the outer air, and planned with due regard to economy and efficiency.

Prospect.—The view to be obtained must not be forgotten; indeed, in the country, it should be a strong factor in determining the general position of the rooms; the hygienic value of being able to look out on a pleasing landscape from the principal rooms must not be lost sight of.

Aspect.—In many plans it is evident that the points of the compass have not been studied by the designer, especially with reference to the outlook of the rooms. Remember that the sun is south at noon all the year round, and that the corridors of rooms should be so planned as to receive the sun at the time of using. As to aspect, northern and north-eastern ones are cold, and southern warm; north-western and south-western aspects have boisterous winds, and with the latter, especially in these islands, we get driving rain and gales; the south-eastern aspect is dry and mild, and forms a very good one for the living rooms of a house.

The different parts of a house should be disposed somewhat as follows:—

The Entrance Hall and Staircase are, as a rule, on a free site, best placed on the north side, so that the sitting rooms may face south. A good square hall, containing an open newel staircase well lighted by a large window and warmed by an open fireplace, enhances the home-like effect of any house, and can be used as an extra sitting-room or lounge.

The long narrow passage called a "hall" in London houses is generally dreary and draughty, whereas a hall should be of a cosy domestic character. The staircase should be at least 3 ft. 6 in. wide, to allow of two persons passing comfortably; to prevent over-fatigue to delicate people stairs should not be designed in longer flights than ten steps without a landing, and the construction should be strong enough to avoid objectionable creaking, which interferes with the quietude so essential to a well-ordered house. The proportion of height to width of tread is important. The rule that twice the height added to width of tread should equal 24 in. will be found to give a comfortable proportion. Servants' stairs are often made with 10 in. tread and 7 in. rise.

The **Dining-room** aspect should be north or east, or north-east. If used as a breakfast-room as well, it should certainly have a few points of east, so as to get the morning sun; this can often be effected by means of a bay window. A western or south-western aspect should be avoided, as the level-rays of the evening sun in the summer tend to make the room hot and unpleasant when it should be cool. The dining-room should, of course, be close to the kitchen quarters, but separated by a well-ventilated servery, so arranged as to prevent kitchen smells from entering the living rooms.

A recess from the sideboard should be formed at the end near the serving door.

For the **Drawing-room** a full south aspect is perhaps the best, but any aspect between south and west is suitable. It should be bright and cheerful, with plenty of window space and with bay windows for extra room. It should give on to the flower garden, and a conservatory in connection is an advantage.

For the **Library** an eastern aspect is good, as dryness is an important consideration; further, it should be retired, and, therefore, quiet, for purposes of study.

The **Morning-room** must face east or, better still, south-east, in order to catch the morning sun. If due east a bay window is a good method of obtaining the southern sun during the morning.

The position of the **Billiard-room** should be a retired one, otherwise it is not important. It is often possible to plan the ground floor lavatories in connection therewith. The ventilation of the billiard-room is an important subject, which will be treated of under that of heating.

In the planning of **Lavatories, Water-closets, and Bath-rooms**, one of the most important points is privacy. On the ground floor a lavatory and water-closet is generally placed in proximity to the front or garden entrances, and provided they are properly screened, it is often a very suitable place. An ideal position is a sanitary wing, cut off from the main building by cross ventilating lobbies; but this is not often carried out on account of the disinclination to mark these conveniences too prominently. A ventilating lobby can, however, generally be arranged.

The **Bath-room** on the first floor may be fitted up with a lavatory having hot and cold water; thus helping in the domestic economy of labour. There is no need to overdo the size of a bath-room, for it can be contained in a room 7 ft. square. There is one important point, namely, that the architect should take care that wherever possible water-closets, bath-rooms, lavatories, &c., should be placed over each other on each floor so that the wastes can discharge into the same down pipes. With regard to **baths**, it is often possible to plan these at the highest point of the drain so that they may act as "drain flushers."

Taking next the **Kitchen Offices**, it is evident that the kitchen should be planned with a view to cross ventilation, so that smells from cooking may not find their way into the house. The aspect should be north or east, being cool and dry, and the position convenient for dining-room and front entrance, so that the latter can be reached without crossing the main hall. (This, of course, refers to cases in which no servants' hall exists.) The cooking range should be planned so that the light comes from the left, to enable the cook to see what she is doing. This is a common failure with young architects, who often seem to think that, as long as light is introduced into the kitchen, its position does not matter. It may often, however, make the difference between a well and badly cooked dinner.

The **Scullery** should have a cool aspect, and be in connection both with kitchen and serving room. The sink should be in front of a window, and of glazed stoneware in preference to stone, into the latter of which the grease sinks. The wall above the sink should be lined for 2 ft. or so in height with glazed tiles, so that the splashings may be easily cleaned off. The flooring should be impervious, and tiles make a good covering, and may easily be washed. The **Pantry** which is used for the cleaning and storing of china, glass, and silver, should be in connection with the kitchen, and may form part of the service room. It should be fitted with a lead-lined butler's sink, and hot and cold water should be laid on. This is preferred to glazed stoneware, as fewer breakages occur. The **Larder** should face north for coolness, and have two windows, to prevent stagnation of air and to create a through draught. The windows should have perforated zinc gratings to prevent admission of flies and insects while the windows are open. It is often a good plan to have a **Summer Larder** placed in the basement, with plenty of air, and it helps to keep the food, &c., cooler in summer.

With regard to **Bedrooms**, they should be planned, where practicable, so as to get as much morning sun as possible, and therefore east, south-east, or south are all good. As old Dr. Fuller said in the seventeenth century:—"An East window gives the infant beams of the sun before they are of sufficient strength to do harm, and is offensive to none but a sluggard." The position of the bed should be indicated on the architect's plans, and should be placed so as not to be in a direct draught between door and fireplace, and so that the sleeper has not his eyes facing the light, and, furthermore, the head of the bed should not be too near the window, otherwise colds and sore throats will ensue. No bedroom can be considered healthy which has no fireplace for ventilation purposes. No bed should be placed with either of the sides against the wall, as the sleeper, on turning over to the wall side, is apt to inhale his own breath again, owing to the impeding of its escape by the wall surface. A fireplace or ventilation flue is required by all sanitary authorities. Besides the position of the bed, the

position of the dressing-table, wardrobe, and washstand should be considered, and the doors and fireplace planned with regard to these.

REFERENCE TABLE.

A Hall	I Smoking Room	S Pantry
B Dining Room	J Kitchen	T Porch
C Drawing Room	K Larder	U Yard
D Library	L Scullery	V Corridor
E Lavatories	M Nurses' Room	W Operating Room
F Bath Room	O Ward	X Coals
G W.C.	P Surgery	Y Bed Room
H Billiard Room	R Living Room	Z Sink

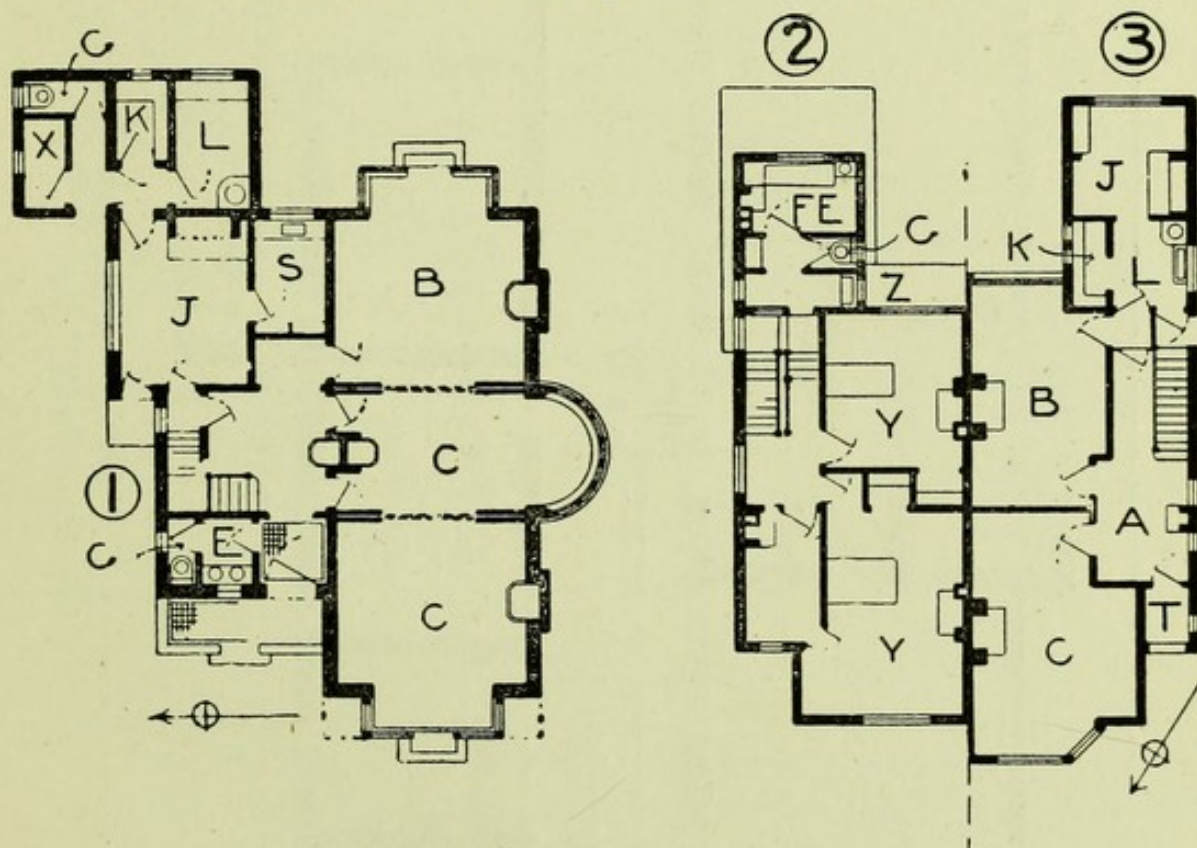

The plans numbered 1 to 15 have been selected as types for different kinds of buildings. They are not given as necessarily the best plan for each building; because each building erected has to be designed according to its site, surroundings, and the personal idiosyncrasies of the owner. It is thought that they will show the student the principles which should guide the architect.

Fig. 1 shows a **detached house** for a suburban site, with

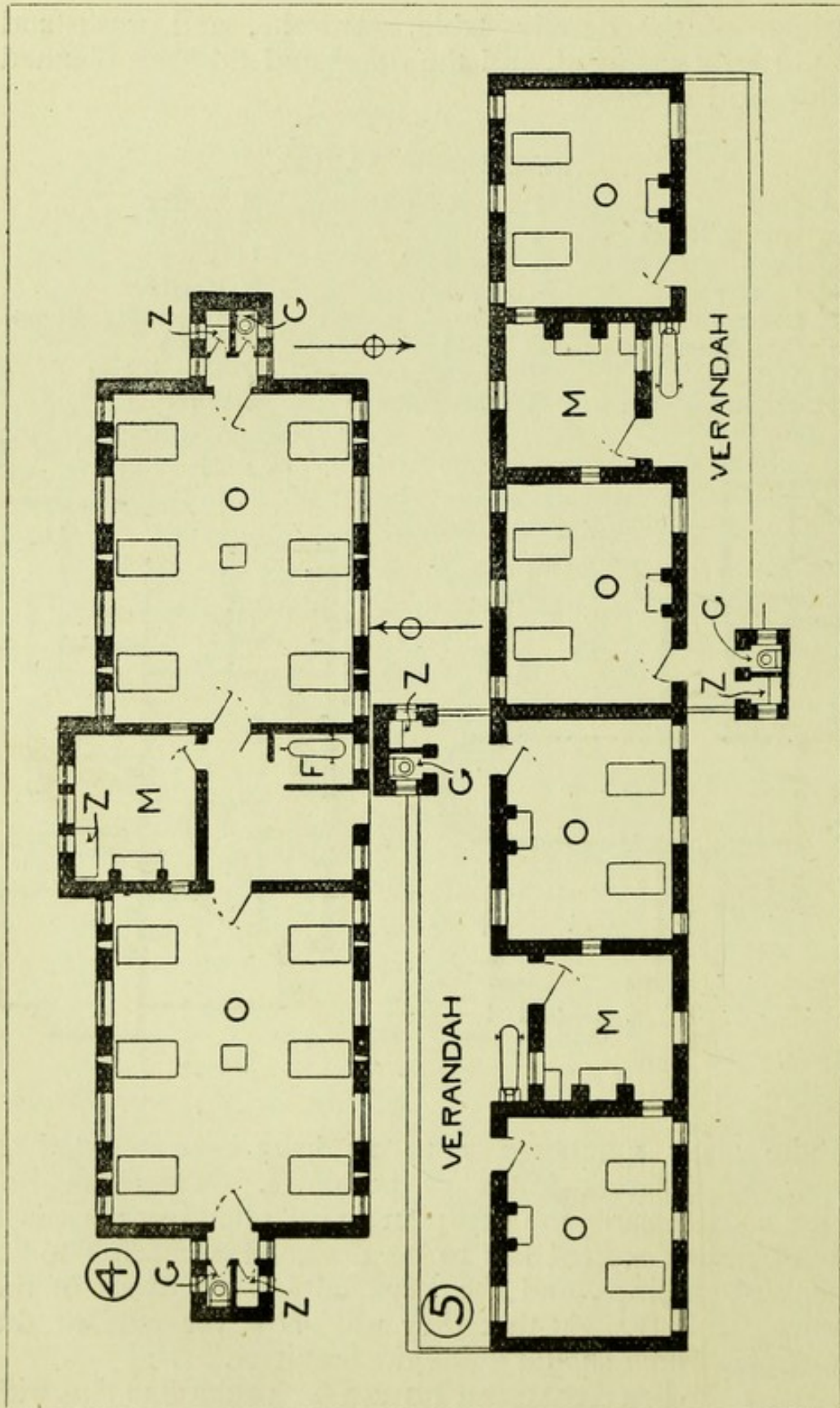

three rooms communicating. An attempt is made to make the hall more inviting, by making it of a squarer shape than usual and adding a fireplace. The lavatories are cut off from the house as much as possible.

Figs. 2 and 3 are the ground floor and first floor plans of a pair of **semi-detached houses**. On the ground floor a square hall with fireplace is given, and the service from kitchen to dining-room is planned for the interception of kitchen smells.

Fig. 4 is a plan of a ward pavilion of an **isolation hospital** for twelve beds on the Local Government Board model. The sanitary wings are cut off from the wards by cross ventilating lobbies; a movable bath is provided.

The wards can be air-flushed by the windows opposite each other. The heating is by central stoves.

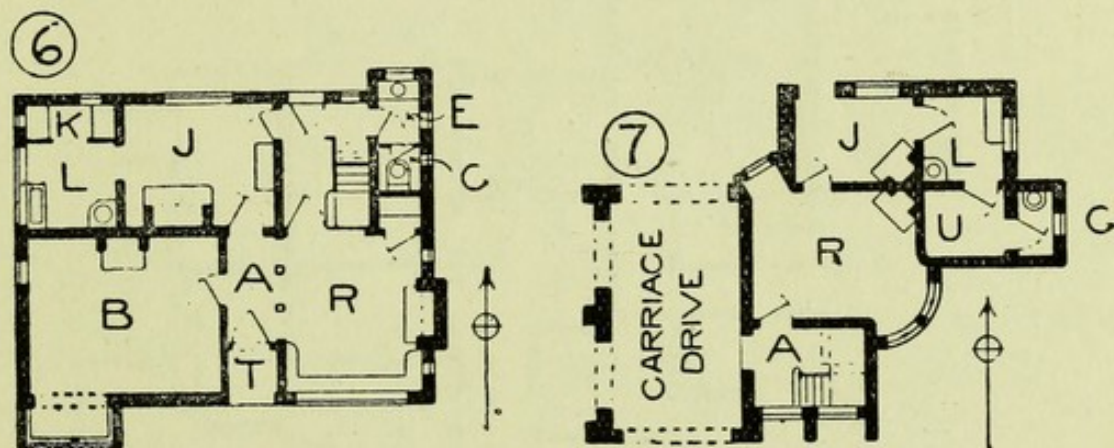
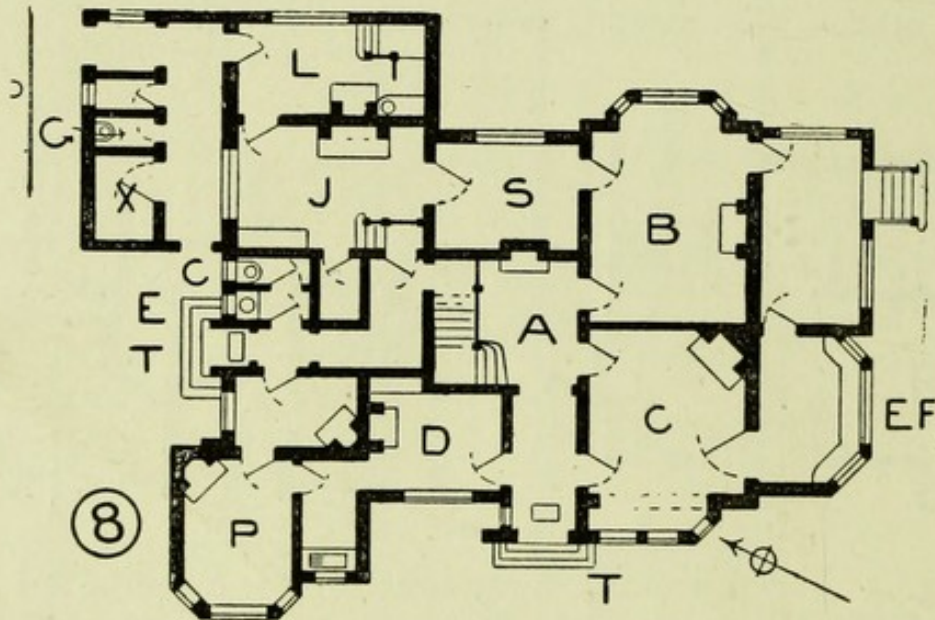

Fig. 5 is a Local Government Board example of an **isolation block** for eight beds. It will be seen that the sanitary blocks are entirely disconnected from the building, and approached by a verandah. Each ward is entirely disconnected, the nurse having to reach them by the open verandah. A bath on wheels is provided.

Fig. 6 is a plan of a small economical **bungalow** consisting of two living rooms: namely, dining-room and hall sitting-room. In this type no passages occur. The stairs are screened off from the hall. The water-closet is entered through the lavatory and has besides an intercepting ventilated lobby. The kitchen, &c., are fairly convenient for the front door and dining-room.

Fig. 7 is the plan of an **entrance lodge**. The unusual shape of living room is necessitated because a look-out window is down the main road and along the private drive. Bedrooms are placed over the entrance carriage drive.

Fig. 8 is the ground plan of a **doctor's small house**. There is a large square hall with fireplace, lit from windows high up in the pantry wall. The consulting-room, surgery, and waiting-room are self-contained, and yet in communication with the house. The surgery entrance is in connection with the waiting-room, as are also the lavatories. The consulting-room is in touch with the front door as the better class of patients would enter here. The pantry would act as a ventilating lobby to the kitchen.



Figs. 9 and 10 represent a pair of **workmen's cottages**; or two of a terrace. There is a large kitchen—living-room, and a bath-room is provided next the scullery. A bath-room is seldom found in a workman's cottage, but it is perhaps more required here than in any dwelling, so that on returning from dirty occupations a warm bath may be obtained. Being close to the scullery, it is readily supplied with hot water, and becomes, in fact, a lavatory and bath-room combined.

Figs. 11 and 12 are the ground and second floor plans of a **town house**. The first floor is omitted because it is

given up to reception-rooms, and needs no explanation.

On the ground floor a good outer hall and entrance hall with fireplace are obtained. The service stairs to basement enable the servant to get to the front door without traversing the inner hall. A vaulted passage 7 ft. wide leads to the dining-room. A small cloak-room and lavatory are placed under the stairs.

The serving-room and service stairs are placed conveniently for the dining-room.

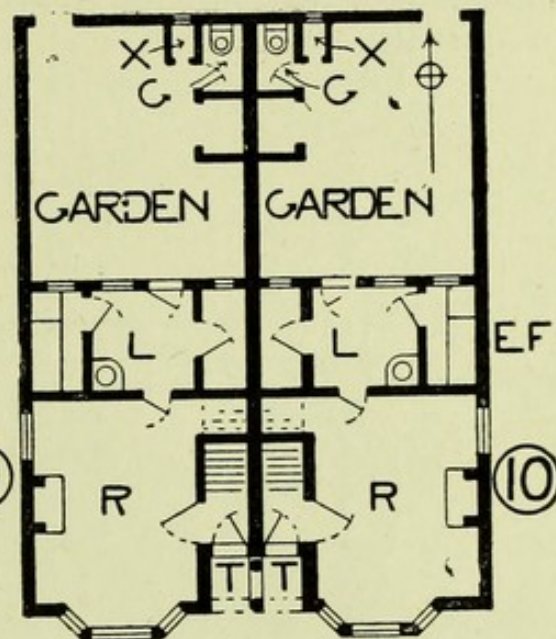

On the second floor are two suites of rooms, front and back, and only lavatories, bath-rooms, and water-closets are lighted from areas.

Fig. 13 is a plan of a hospital for a country town. It is laid out so as to catch all the air and sunshine possible. At the end of each ward are two sanitary wings, each with a cross-ventilated lobby. In one are the water-closets and sinks, and in the other the bath-room and lavatory. A

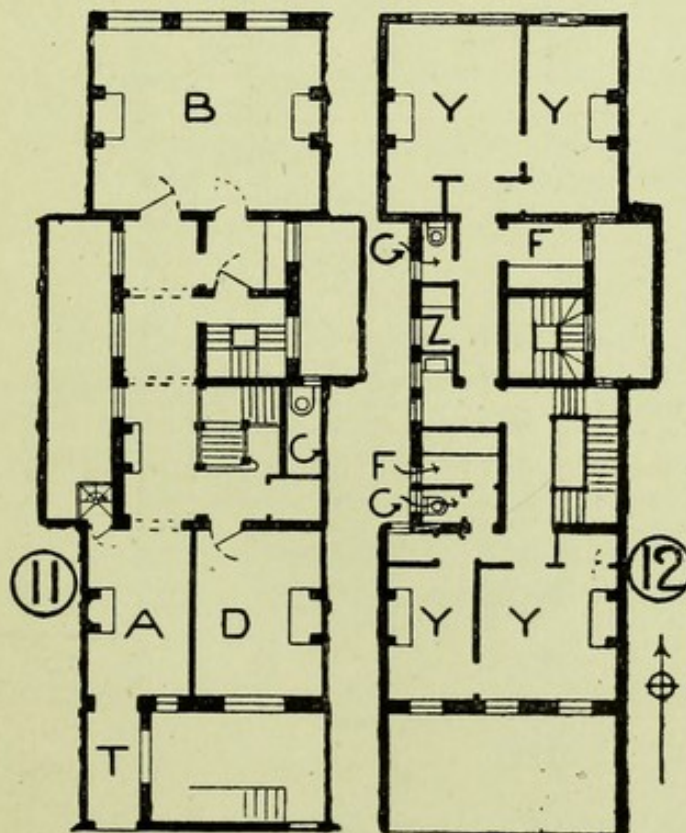

GROUND FN. FIRST FL.

small nurses'-room and ward kitchen are placed at the inner

end of the ward. In this case the wards are warmed with radiators and with open fireplaces.

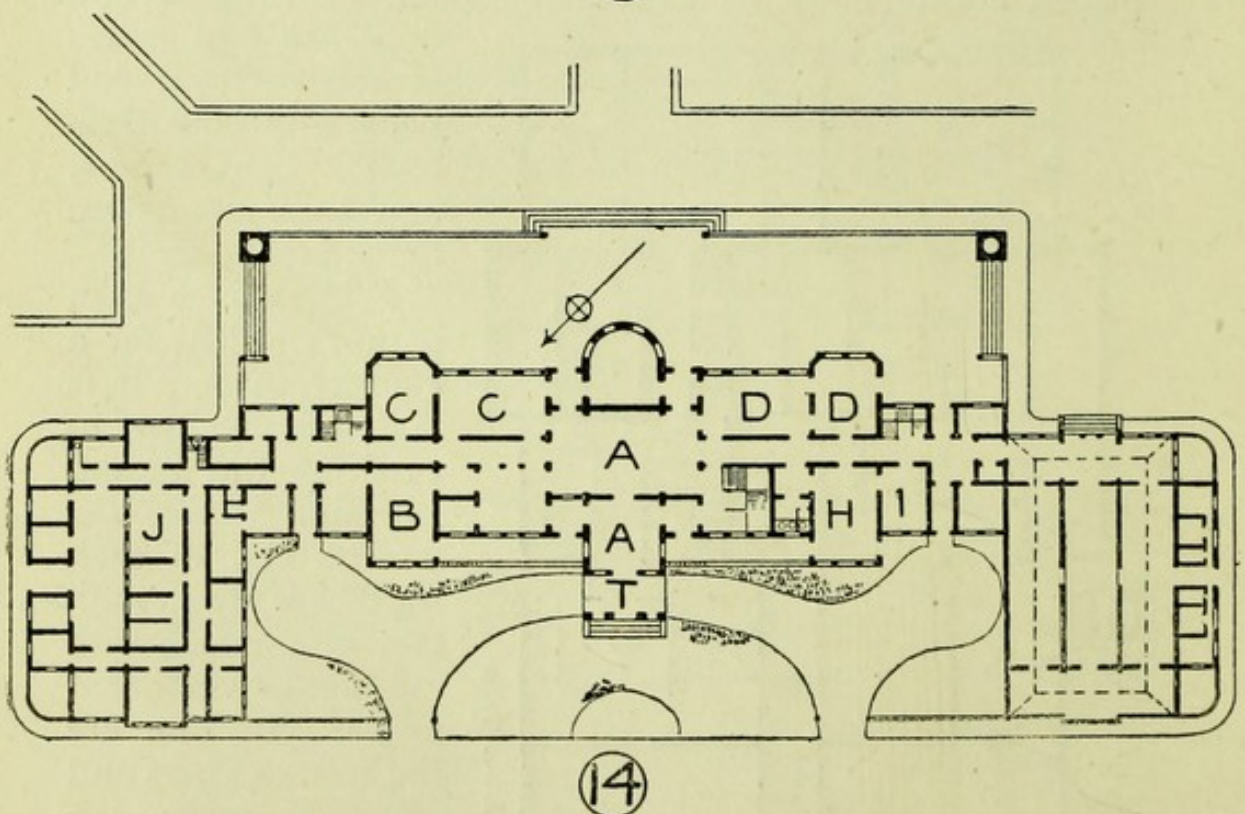
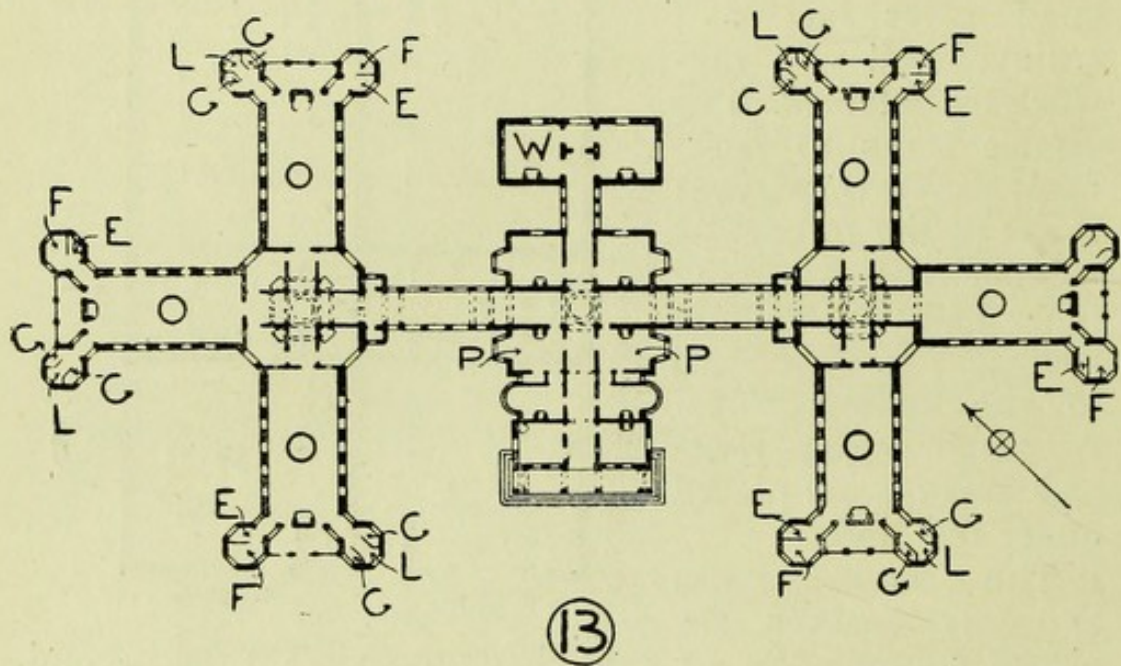

Fig. 14 is the ground plan of a large **country house**. It forms a crescent shape on plan so that all the living rooms may, as far as possible, get the sun's rays at some portion

of the day. The kitchen block wards off the cold north-east winds. The dining-room is easily served from the kitchen, and faces north for the sake of coolness. In consequence, a morning-room is provided which can be used as a breakfast-room. The billiard-room is in connection with the ground-floor lavatories. The conservatories and winter garden are placed so that the sun is on them during the whole of the day.

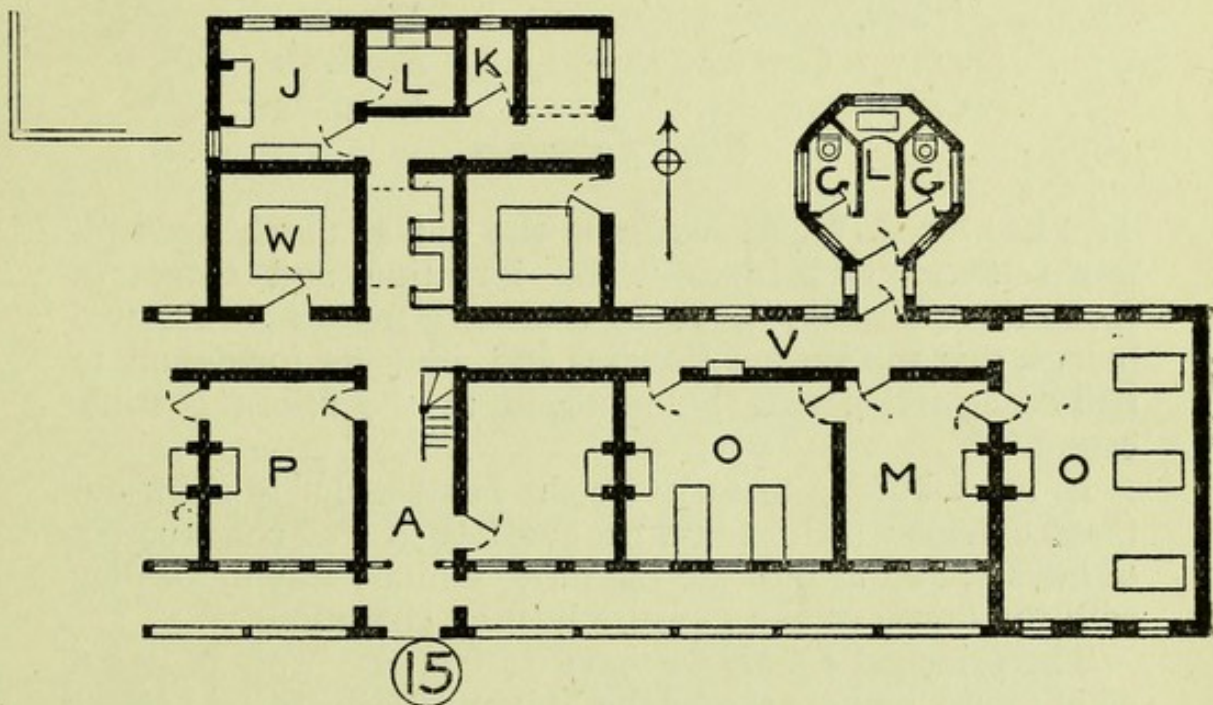

Fig. 15 is rather more than half the plan of a **cottage hospital** for twelve patients. The central portion contains the surgery and nurses' rooms, operating theatre and mortuary, kitchens, &c. On either side of the central block are a two-bed and a three-bed ward, and sanitary blocks with cross-ventilated passages containing bath-room, water-closet, sink, &c.

CHAPTER V.

SANITARY CONSTRUCTION.

Walls.

Damp Courses.

Chimneys.

Floors.

Roofs.

Furnishing.

Wall Coverings.

THE late Sir B. W. Richardson, who did so much for sanitary science, said that "The intention and object of domestic sanitation is so to construct houses for human beings, that the various diseases and ailments incidental to bad construction may be removed to the fullest possible extent."

In the following remarks we shall endeavour to point out those defects which should be avoided in the construction of houses, and to indicate the most sanitary way of dealing with the house so as to ensure healthy conditions.

The principal enemy we have to contend with is *damp*, which must be kept out of the building if it is to be healthy and fit for occupation. The materials used in building should therefore be as compact, dry, and as impermeable as possible. The site should always be covered with concrete, as explained in Chapter II., and it is evident that materials which are as non-porous and non-absorbing as possible should be used in the construction of the house, and especially those which hold as little as possible of noxious substances which, when set free, are diffused and cause disease. Bricks should be as free from porosity as possible, wood sound and well seasoned, and plaster and other wall coverings impermeable.

Walls.—In the component parts of a house, walls are an important element, and we may fitly discuss their construction from a hygienic point of view. Walls are

usually constructed of brick, stone, timber, or concrete, on the quality of which depends the good or bad character of the structure in which they are built.

The porosity of any building material can be tested by placing it in water for a definite time and weighing it before and after absorption. The following is a list of different materials with their absorption per cent. of their dry weight, according to Rivington:—

Granite	$\frac{1}{2}$ to 1	per cent. of its weight.
Malm bricks	20 to 22	” ”
Grey stocks	10	” ”
Hard stocks	$7\frac{1}{2}$ to 8	” ”
Common stocks	10	” ”
Blue Staffordshire bricks	6	” ”
Good sandstones	8 to 10	” ”
Portland stone	14	” ”
Bath stone	17	” ”
Kentish rag	$1\frac{1}{2}$	” ”

An ordinary London stock absorbs about one-tenth of its weight. It should be mentioned that a brick backing, which is often only $4\frac{1}{2}$ in. thick, but which should not be less than 9 in. thick, is generally placed behind all stone walls. Care must be taken that the backing is thoroughly bonded with the stone facing.

The principal consideration in building brick or any walls is to keep out the damp. Damp may enter the building in two ways, viz. :—(a) horizontally through the walls through damp earth or by rain driving against the surface, and (b) vertically, by the action of the ground water, in being drawn up by capillary attraction. (a) The horizontal entrance is prevented by a vertical damp course, by hollow walls, by areas, or some impermeable covering such as tiles or cement affixed to the wall. (b) The entrance of damp vertically is prevented by a horizontal damp course of some non-absorbent material through which the ground water cannot pass.

Damp Courses.—Before proceeding to discuss the various methods of applying damp courses to suit different

purposes, we will look at the various materials used for the purpose.

1. Two courses of slates in cement, the slates being laid so that they break joint, are a very usual but not very effective way of preventing the uprising of the damp, as the slates are liable to crack with the slightest settlement of the wall.

2. Asphalte is frequently used. Seysell rock asphalte, laid in two layers of $\frac{3}{4}$ in. each, forms a very good damp course. The ordinary tar asphalte is cheaper, but not so effective.

3. Lead has been used to form a damp course, but is not now often employed.

4. **Callender's** patent bituminous composition may be mentioned, as it has been much used in England. It is sold in sheets of varying widths, and is useful for both vertical and horizontal damp courses. One of the useful properties that it possesses is its elasticity, so that in case of a settlement in the building it is still effective. It should be laid with lapped joints, the pressure of the wall above forming it into one homogeneous mass.

5. Another form of damp course is to place a course of **air bricks** round the walls. These should be formed of vitrified fire or other clay which is non-absorbent, and which, being set in cement on the under and upper surfaces, effectually prevents the entrance of damp, and at the same time ventilates the space under the ground floor, thus preventing any tendency to dry rot in the timbers. In putting damp courses into old buildings where they have been omitted, this is the best and cheapest method, as a course of bricks can be cut out all round the building, and the air bricks inserted in sections.

All **horizontal damp courses** should be fixed at a height of not less than 6 in. above the surface of the ground adjoining the wall, and, of course, underneath any wall-plates and flooring which it is essential to protect from damp.

Illustrating these remarks by actual examples, we have, firstly, as a common instance, (i.) a **house without a basement**, which is simply treated with a damp course

placed, as shown in fig. 16, not less than 6 in. above the surface of the ground. It is not advisable to place it nearer than 6 in. to the ground, because water might splash or be blown against it, and so be drawn up into the walls above it.

(ii.) In **habitable basements**, or, what is the same thing, a building in which the lowest floor is below the level of the ground, it is necessary to prevent any damp entering the wall

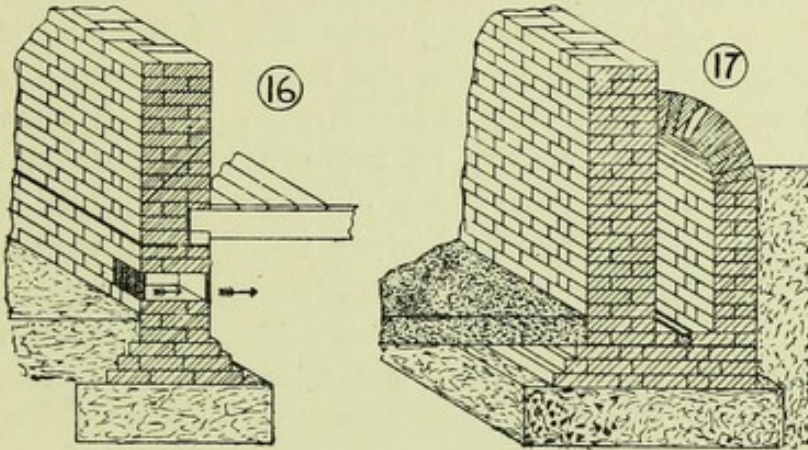

horizontally as well as vertically. This is effected either by means of an asphalt lining in two thicknesses of $\frac{3}{4}$ in. each, as shown in fig. 18, or by means of what is known as a "dry area" placed outside the wall, and either left open and drained or covered over and ventilated, as illustrated in figs. 17 and 19. This dry area may be 12 in.

wide, or it may be only $2\frac{1}{2}$ in. wide, in which case it becomes really a portion of a hollow wall to the basement, fig. 20. The cavity should be carried up 6 in. above the surface of external ground, and a damp course inserted at the base and top of the cavity.

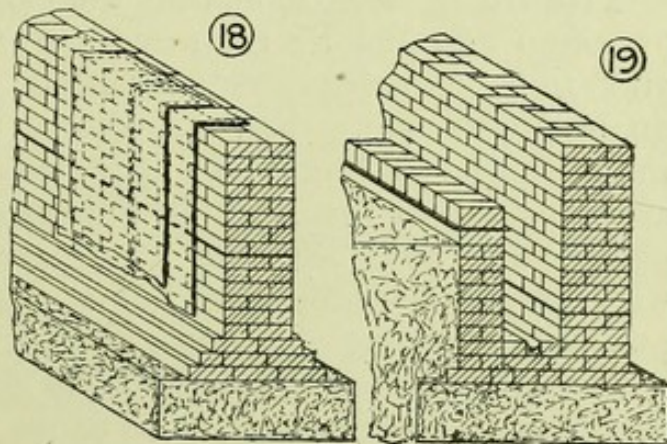

In exposed situations, hollow walls may be used with advantage. These walls (figs. 20 and 21) are usually brick and one-half brick thick respectively, and are connected together with bonding bricks at intervals. Architects differ as to whether the

brick or half-brick wall should be placed externally. There are advantages and disadvantages in both, but on the whole it seems better construction to put the half-brick wall externally, so that the floor and roof timbers can rest on a solid 9-in. wall.

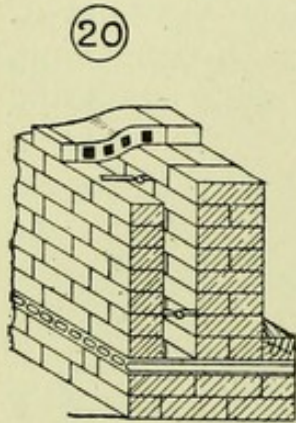

The bonding bricks are of the shape shown in fig. 20, the reason for which is that rain may not be drawn through from the outer skin to the inner one, and so do away with the advantage of the hollow wall. These bonding bricks are therefore curved upwards so as to prevent the rain being drawn in. The section is also shown in fig. 21 through a head and sill of a window in a hollow wall, showing how the damp in the cavity is prevented from touching the woodwork.

Walls, especially at the seaside, are often protected from the driving rains by having their faces rendered in cement, which, although not generally pleasing in appearance, is certainly effective.

Tile-hung walls, as they are called, are often adopted for the same purpose, and form a well-protected surface on an exposed site. Fig. 22 shows one method of effecting this. Tile battens are plugged to the wall at the proper gauge, and to these the tiles, formed with projecting nibs, are hung. This method of roofing the walls, as it were, is very effective; a tilt is generally given to the bottom course, so as to throw the rain falling on to it clear off the wall. By using Wright's fixing blocks, battens are dispensed with, the tiles being nailed direct to the blocks. The tiles may also be secured by being plugged direct into the joints of the brickwork.

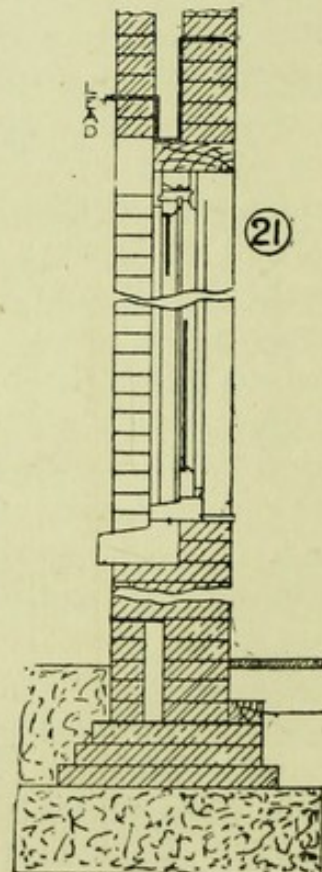

Old, damp, and porous walls can often be treated with tile hanging, cheaply and effectively, for the prevention of damp.

Chimneys should never have less than one brick external walls above the roofs; they should be built in cement mortar, and provided with a slate in cement damp-proof course just above the roof level, so as to prevent rain-water soaking into the roof timbers. Chimneys should be kept as much as possible together, and be as protected as may be, so as to ensure a good draught.

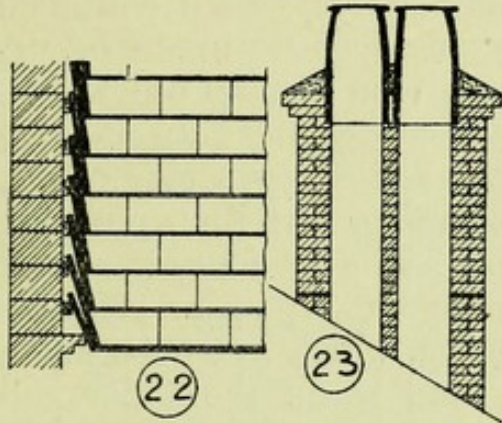

Wall coverings, Internally.—An ideal wall covering is one which is impervious, and which, having a

smooth surface, can be easily washed. In this respect **glazed tiles** are an excellent covering, and can be used in bathrooms, sculleries, water-closets, and suchlike places, and can be kept clean and sweet by frequent washing. Fig. 24 shows an application of ordinary plastering finished with a painted surface, which is cheap and effective, silicate paints being preferable to those containing lead. Zinc white should be used in preference to white lead, because it is not affected by sulphuretted hydrogen, and it is more healthy to work with. For bedrooms, distempering is even perhaps better than painting; it is cheaper, and can be executed frequently in bright and cheerful colours.

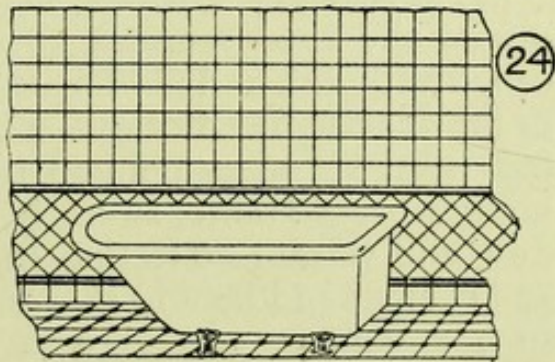

Ordinary pulp papers are not desirable as wall coverings; they are most unwashable, collect the dust, and are absorbent. To remedy this washable papers were introduced. Cheap papers may be varnished, and so rendered more

wholesome. In no branches of house furnishing have so many improvements been introduced of late years as coverings. These are too numerous to mention, except that they are of the Lincrusta type, and as easily cleaned by washing, although most of them err in departing too much from a flat surface, for the raised patterns excel as dust and dirt catchers. Enamelled iron set in wooden frames is useful for restaurants and suchlike places, where continual cleansing is necessary. Ceiling coverings are made in the same kind of papers, but plastering is in general use, which, when whitewashed or distempered in colours, answers very well, and can be easily cleaned. Ceiling papers are bad, because of inaccessibility for cleaning, and their power of retaining and multiplying germs. The ordinary lime and hair **plastering** is to be deprecated on many grounds. The **Danville Asbestic** plastering, which has been much used in America and Canada, and is on the walls and ceilings of the Carlton Hotel, has much to recommend it. It is fireproof, having resisted tests up to 2,000° F., germ proof and sound proof; so that it is a material that can be advantageously used in many situations.

Floors may be considered under—

- | | |
|----------------------|-----------------------------|
| (a) <i>Ordinary.</i> | (c) <i>Floor Coverings.</i> |
| (b) <i>Solid.</i> | (d) <i>Ventilation.</i> |

(a) **Ordinary Floors**, constructed with wooden joists placed one foot apart and covered with floor boarding, and ceiled with lath and plaster beneath, are unhealthy, because of the accumulation of dirt and dust which takes place. It has been so often pointed out that we cannot expect to know what "Home, sweet home," really means, until the dust and vermin collecting in cracks between floor boards and ceilings and behind skirtings cease to exist. Every time such a floor is washed it is only another addition to the accumulation of filth which passes through the open joints of the floor boards to rest on the plastered ceiling beneath, as shown in fig. 25. Whenever such a floor is used, it should be covered with grooved and tongued, or ploughed and tongued, boarding, so as to prevent the dirty water and dust from falling between the boards. This method is shown in the fig. at A.

(b) **Solid Floors** of whatever form, should be used where possible in order to prevent the chance of dust and vermin being harboured in cracks and crevices. Ordinary wooden joists are sometimes used, placed side by side; this method was patented many years ago by Messrs. Evans & Swain (see fig. 26) for fire-resisting purposes. In this case the floor boarding is nailed direct to the upper surface, and the lower side of the joists have dovetailed grooves formed in them so that the plastering may have a better key, or the joists may be left exposed on the under side, a V-joint being formed between the joists.

We have said that any system of solid fireproof floor is preferable to the ordinary floor. It would be foreign to our

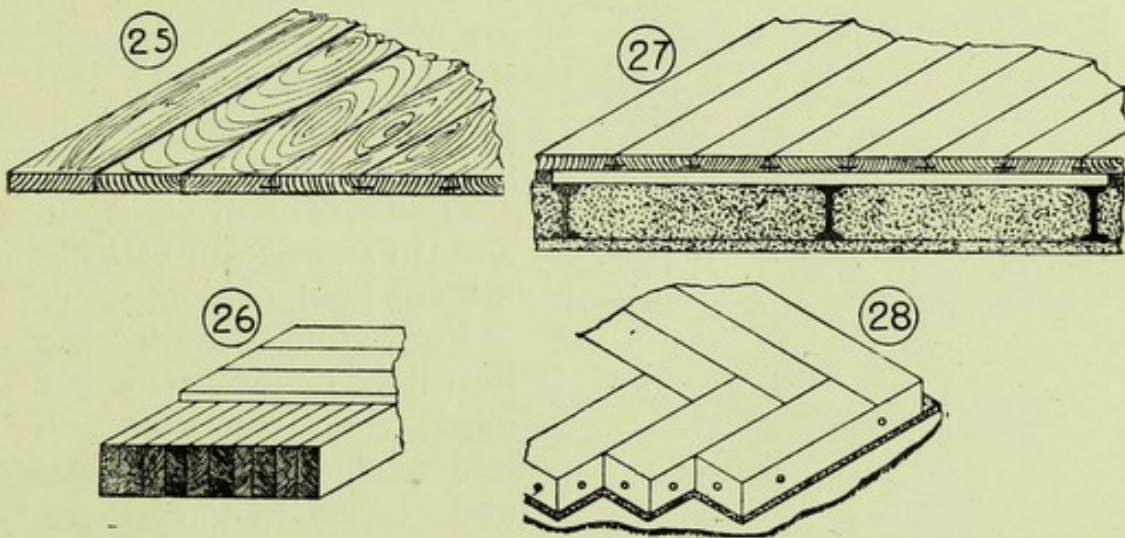

purpose to inquire into these, but we may mention a system which is practically as good as any of them, and which costs little more than the ordinary combustible wooden floor. The system referred to is that in which steel joists, 5 in. or 6 in. deep, are placed, about 2 ft. apart, and the space between filled up with 6 in. or 7 in. of coke-breeze concrete (fig. 27), composed of coke-breeze and Portland cement (about 4 to 1). The concrete is taken 1 in. below the bottom flange of the girders, so as to protect them from fire, and to enable the ceiling to be plastered. The floor-boards can be either nailed direct to the concrete or rest on fillets, about 3 in. by 2 in., laid flat, and fixed to the concrete. The space thus formed is useful for running gas and water pipes, &c. If

the boards are nailed direct to the concrete, there is no space for collection of dirt; but in that case care must be taken that the concrete is thoroughly dry before laying the boards, otherwise dry-rot may set in.

(c) **Floor Coverings.**—The floors of bath-rooms, sculleries, water-closets, larder, lavatories, greenhouses, and sometimes of halls should be covered either with hydraulic pressed tiles, marble, mosaic, or some substance of a non-absorptive character, so that they may be washed down frequently. In the case of lavatories, bath-rooms, and sculleries, the floors are best laid sloping, so that when washed down the dirty water may be led, by means of a duct pipe, into a rain-water head or to discharge over a gully trap.

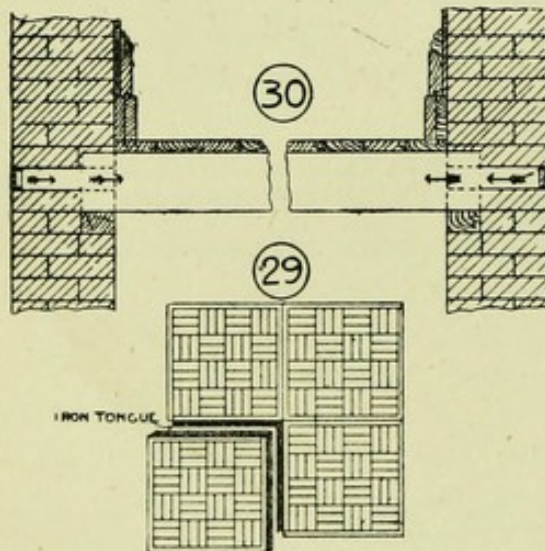

Ordinary basement floors are best finished with solid wood blocks (fig. 28), laid either straight or herring-bone on a 6-in. bed of Portland cement concrete, and in some form of bituminous composition.

For ordinary rooms the best floor covering is either hard wood, such as oak laid in half-batten widths and beeswaxed and polished, or good selected

deal, stained and well varnished, forms a good covering. The edges of the boards should be grooved and tongued.

Parquet flooring (fig. 29) may be laid over the whole surface in order to ensure an uniform and impervious surface without cracks in which dust may accumulate. It may be cleaned with a mixture of turpentine and beeswax.

Carpets should **never** cover the whole floor, but should be left with a margin of parquet or stained and varnished boards, so that the corners of a room, where dirt most readily accumulates, can be easily cleaned, and the carpet may be taken up and shaken without moving the furniture, most of which is usually placed against the walls.

(d) The **ventilation** of the space under floors is always

necessary where there is a space between the floor boards and ceiling (see fig. 30), and when a wooden floor is placed over the concrete or other foundation laid on the ground; otherwise dry-rot will set in, and the floor timbering gradually rots away and perishes. This ventilation is effected by means of perforated iron gratings or air-bricks built into the outer walls, and so arranged that cross ventilation is produced. In many old buildings, floors are continually having to be taken up because of this precaution having been neglected.

Roofs and Coverings.—Although attics with sloping ceilings are placed in the roof for economy, they are bad from a sanitary point of view, because of being extremely

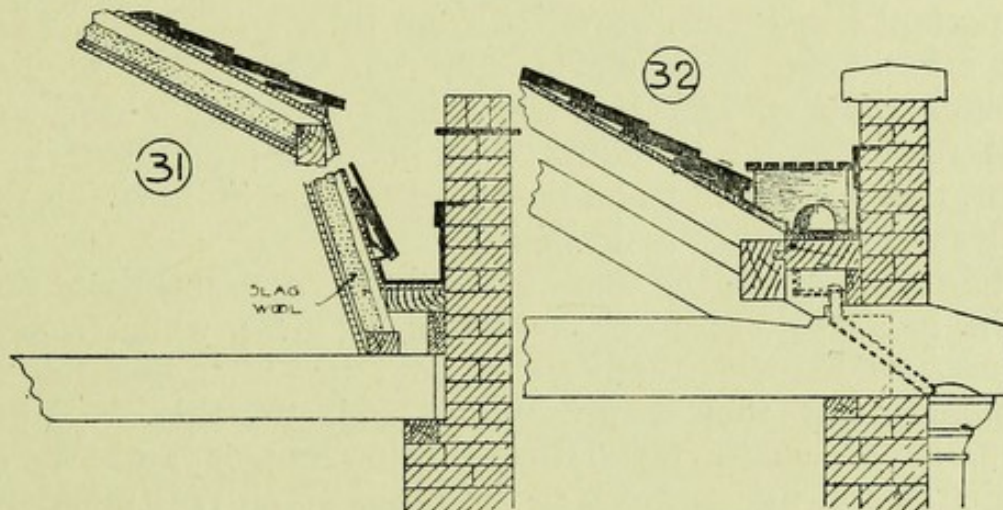

cold in winter and hot in summer. Care must, therefore, be taken to keep an air space between the ceiling of the room and the outer covering of the roof; or, if the whole of the room is in the roof, to fill in between the rafters with slag wool and to place roofing felt or Willesden paper under the slates or tiles (fig. 31). In all cases it is advisable to have rough boarding and not battens under the slates, the continuous wood surface forming a non-conducting material. The eaves of roofs should project so as to protect the wall from rain, and the latter should not be allowed to run down the walls and make them damp.

Cornices and all projections should be constructed to throw off the rain by means of "throating" and weathering.

Rain-water Gutters should have a sufficient fall to carry water off quickly to the drain-pipes. **Lead Gutters** behind parapets should be wide enough to walk along in (at least 12 in.), and should be provided with snow guards (fig. 32), so that when the thaw comes after snow the snow-water can drain away unimpeded by the bulk of the snow, otherwise it may block up the channel, finding its way through the tiles and slates of the roof, and thus injure the ceilings and internal fittings beneath. These snow-guards are formed of transverse bearers, across which laths are nailed, $\frac{1}{4}$ in. apart, the bearers being arched to allow of the water passing along the gutter. As to the comparative advantages of different roof coverings a few remarks may be made.

Tiles are warmer in winter and cooler in summer, both important considerations, apart from their appearance. On the other hand, they are heavier than slates, and require stouter timbers, and the bad kinds are very absorbent. But there can be no doubt that, being non-conductors of heat, they are much to be preferred on houses in which the attics are utilised as bedrooms.

Slates possess the qualities of being non-absorbent and light, but they are good conductors of heat, which causes houses roofed with them to be cold in winter and hot in summer, and they are therefore objectionable. These remarks especially refer to the thin Bangor and Welsh varieties, and not so much to the heavy green Westmoreland slates, which are to be preferred.

Lead, zinc, and copper are all used for flat roofs; they are good conductors of heat, and, therefore, bad from this point of view, though their impervious qualities are good.

Furnishing.—The house being built, it is further evident that in furnishing woolly and fluffy materials are bad; heavy curtains to beds and windows, carpets which cover the whole room, and which are **nailed** to the floor, so as to prevent them being properly cleaned and shaken, are all unsanitary. Finally, all materials and fittings that will allow of the lodgment of dust, which absorb dirt in any form, and which on being shaken yield a harvest of dust, should not be used.

CHAPTER VI.

HOUSE DRAINAGE.

UNDER this section we shall consider underground drains, and include their laying, inspection, and general disposition.

Stoneware Drain Pipes.—Underground drains should be constructed of glazed stoneware. The pipes are usually made in 2-ft. lengths, and are of cylindrical form, with a "socket" at one end and "spigot" at the other. Both ends have ridges and furrows formed on them, so that the jointing materials are more easily held in position. In London those that have been tested by hydraulic pressure should be used.

The pipes should be truly laid and securely jointed, and should have a fall of at least 3 in. in 10 ft. (*i.e.*, 1 in 40) for 4-in. pipes, 1 in 60 for 6-in. pipes, and 1 in 90 for 9-in. pipes. In ordinary house drainage a fall of 3 in. in 10 ft. (1 in 40) is generally adhered to where it is possible to obtain it, but in towns one often has to be content with $2\frac{1}{2}$ in., or even 2 in., in 10 ft. A long drain with a flat gradient should always have an automatic flushing tank at its highest point, so as to ensure thorough flushing at intervals.

All drains should be laid as straight as possible from one point to another, thus shortening the length of drain, facilitating cleansing and inspection, and ensuring that the excreta shall be carried away as quickly as possible. Where it is necessary to have bends, they should be of as easy a curve as possible, so that no obstructions may be likely to occur.

The pipes should be laid on a bed of concrete 6 in. in thickness (as shown in fig. 33), formed with care to the required fall. The pipes are then laid in position, commencing at the lowest part of the drain, the spigot end

being placed in the socket end of the pipe next below it. The space underneath the body of the pipe should then be packed up carefully with concrete, so that the whole of the pipe, and not only the socket, may rest on the solid concrete. If the latter only rest on the concrete, any weight from above would be liable to cause the fracture of the pipe, on account of its support being only at intermediate distances.

Jointing.—The jointing of drain pipes is a most important consideration, and too much stress cannot be laid on this point. The drains may be in perfect alignment on a solid bed of concrete, but the drainage system will be faulty if the joints between the pipes are not absolutely water-tight.

The simplest and one of the best joints is, without doubt, that formed with neat Portland cement or in cement and

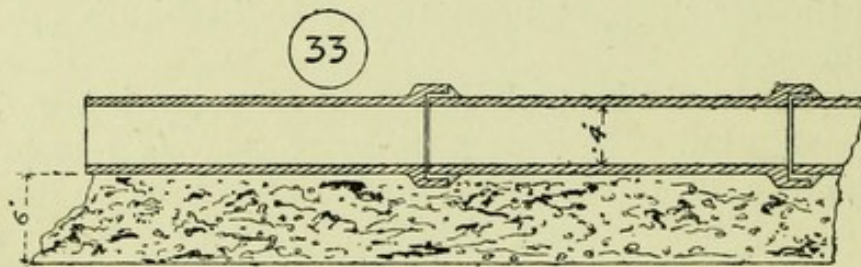

sand in equal proportions wiped round the socket before the spigot is driven home into position. The inside of the pipe should then be carefully wiped out to preserve the clear bore of the pipe without obstruction, and a fillet of cement should be wiped round the outside of the joint. In order to ensure that the bore of the pipes shall be quite clear at the joints, cylinders of india-rubber are sold for various sizes of pipes, and these can be drawn through by the drain layer as each section is placed in position. In laying the pipes care must be taken to keep the bore of the adjacent pipes concentric. If cement be placed in the bottom only of a socket and the next pipe pushed home, the weight of the pipe will displace the soft cement until the spigot end of the one rests on the inside of the socket of the other. The joint is too close at the bottom, too wide at the top, and there is a ridge inside each joint. The pipe can be packed up with

brick chips, or a gaskin of yarn all round is sometimes used. In making joints the hands should be able to reach every part of the outside of the pipe. The fillet formed on the outside should be trowelled smooth all round.

Various patent methods and substances for making joints have at times been placed before the profession.

Patent Joints.—Chief amongst these is that known as "Stanford's" joint, shown in figs. 34 and 35, in which a composition of coal-tar, sulphur, and ground pottery is formed on the spigot and socket ends of the pipes, which are then greased and fitted into one another. The ball-and-socket principle allows of a certain amount of deflection, and the possibility of obstruction by cement passing into the body of the drain is avoided. Another method is

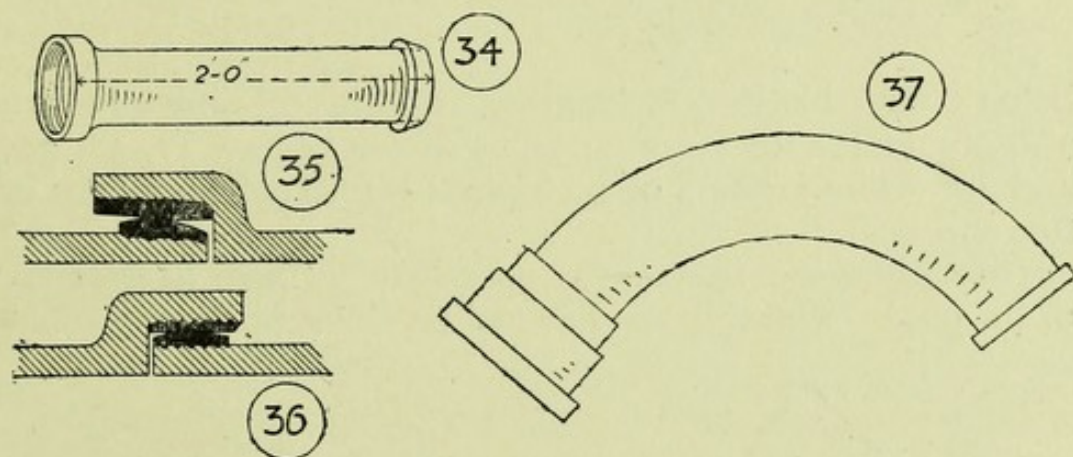

Doulton's patent self-adjusting joint, which is supplied on the best London tested pipes. In this the joint is effected as shown in fig. 36. Doulton's patent joint is very useful in relaying drains where the flow of sewage cannot be altogether stopped, as in large hotels and public institutions. The pipes can be laid in the water, but when completed a fillet of Portland cement should be placed outside each socket.

A caution is necessary here against the joining of pipes by means of clay, for, until within comparatively recent years, clay was frequently used. Of course it forms no reliable joint at all, and should on no account be allowed. It has sometimes been employed in connection with cement, the inner part of the joint being puddled around with clay ;

but a little reflection will show that if it is bad anywhere it is bad everywhere, and it should never be allowed to be used.

Iron Drain Pipes.—Iron pipes are preferred by some architects, especially for drainage under houses, one of the chief reasons for their employment being that systems in which they are employed have fewer joints—the iron pipes

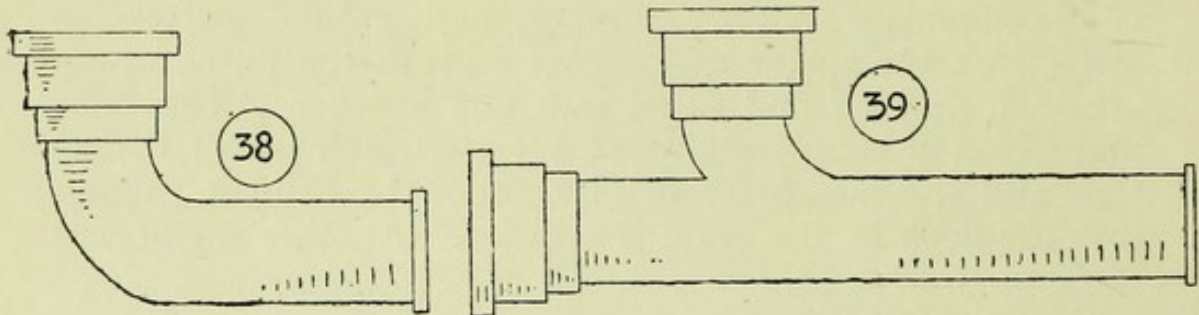

being obtainable in 9 ft. lengths. Bends and junctions are also obtainable for these pipes, as shown in figs. 37, 38, 39, and 40. The jointing of such pipes is effected by means of tow and lead.

Iron pipes are frequently necessary in deep basements, or in places where pipes have to be slung up to the walls,

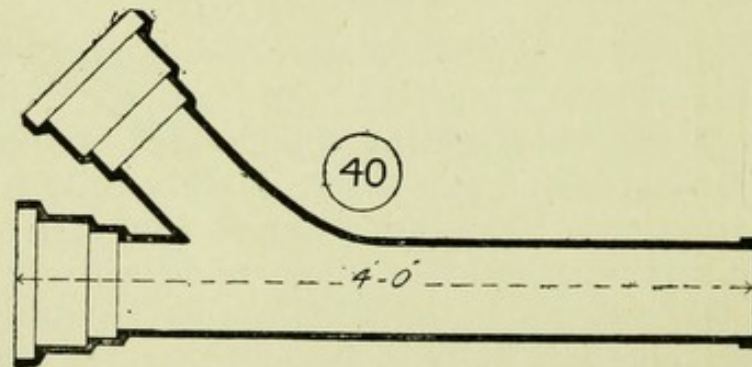

owing to the depth of the sewer being such that they cannot be taken under ground. In such a drain iron pipes, because of their transverse strength, are easier to place in position.

Whenever iron pipes are used, they should be subjected to some preservative process in order to prevent them from rusting. In the **Bower-Barff** process the pipes are

subjected for some twelve hours to the action of super-heated steam, after having themselves been raised to a very high temperature; they thus become coated with the black oxide of iron. In **Dr. Angus Smith's** system the pipes are heated to a certain degree and then dipped in a special solution. Neither process can be considered quite perfect, for an accident may chip off the oxide coat formed by the Bower-Barff process, or Dr. Angus Smith's composition may wear slowly away; but it should be mentioned that it is calculated to last about forty years.

The case for and against the use of iron pipes has been debated over and over again. Architects, as a rule, prefer glazed stoneware pipes because they are practically indestructible from the interior. But iron pipes are often specified for under-house drains because of the fewness of joints. Even in this case some prefer stoneware pipes, provided they are encased all round with 6 in. of concrete. In America the general opinion seems to be entirely in favour of iron piping.

Size of Pipes.—With regard to the size of drain pipes that should be used, there is no doubt that in the past the mistake has been in using pipes of too great a diameter. For ordinary dwelling-houses, pipes of 4 in. internal diameter are quite sufficient. A pipe of 4 in. diameter with a fall of 1 in 40 will discharge 140 gallons per minute, which is never likely to be exceeded in an ordinary dwelling house.

In large mansions or in public buildings the size of the pipes must be increased as the system gets nearer the outlet and receives more discharges. This is usually effected where manholes occur by means of half-taper pipes, as described later; but an illustration is shown of an ordinary whole taper pipe (fig. 41). In addition to the ordinary straight pipes, 2 ft. long, other pipes of different forms are made to answer certain purposes.

Junctions.—Chief among these are the **junctions** which are necessary where one line of pipes is connected

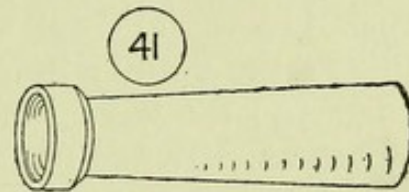

to another line. The chief point relative to the construction of these is that they must be made in the direction of the sewage, never at right angles; this is necessary in order that the contents may be directed well in the direction of the fall. Junctions are best made by means of half pipes in inspection chambers, but short branches from soil pipes and wastes may be joined to main drains direct by means of ordinary junctions. Junctions are effected by means of

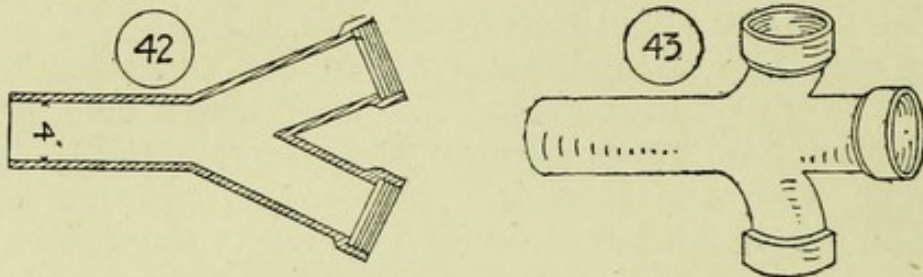

the V-junction, double junctions, single or Y-junctions, and taper junctions. Of these the Y-junction is shown in fig. 42; the double junction in fig. 43; the single junction in fig. 44; the taper junction in fig. 45.

Bends.—Bends are necessary where the drainage has to be led round a corner. Bends of various curvature are made to suit special circumstances. Of these, figs. 46 and 47 are shown, so that the student can realise their shape. Bends should be used with care and so as to prevent all

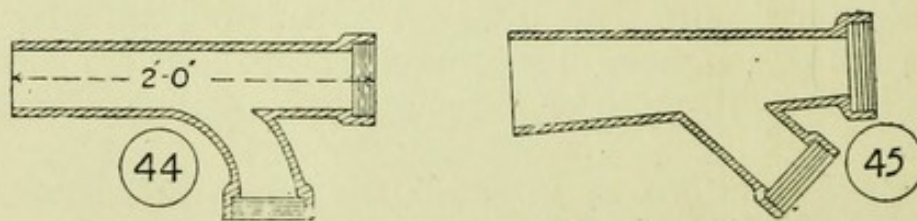

sharp turns, which would have a tendency to impede the flow of the sewage. A taper bend is also shown in fig. 48.

An excellent bend made by Messrs. Broad & Co. is the "pedestal bend," shown in fig. 49. This is to take the discharge of the vertical soil pipe where it meets the ground drainage. It will be seen that it has a horizontal base fixed to it, so that a direct seat can be obtained on the concrete bed which would be laid to receive it.

Inspection of Drains.—Although a system of drainage should if properly executed be faultless, and in fact may be so, yet in practice it is found to be necessary to have at certain points along the line of pipes means of access, so that by means of drain rods any obstruction can be removed if occasion requires it. This is the more necessary, inasmuch as the domestic servant seems to regard the water-closet pan as the proper receptacle in which to deposit anything that cannot be got rid of in any other way without trouble. Such being the case, articles are often passed through the water-closet trap and so into the drains which ought never to be deposited there; for instance, old rags, &c., and so it comes about that drains get clogged up.

Inspection Chambers (or manholes, as they are some-

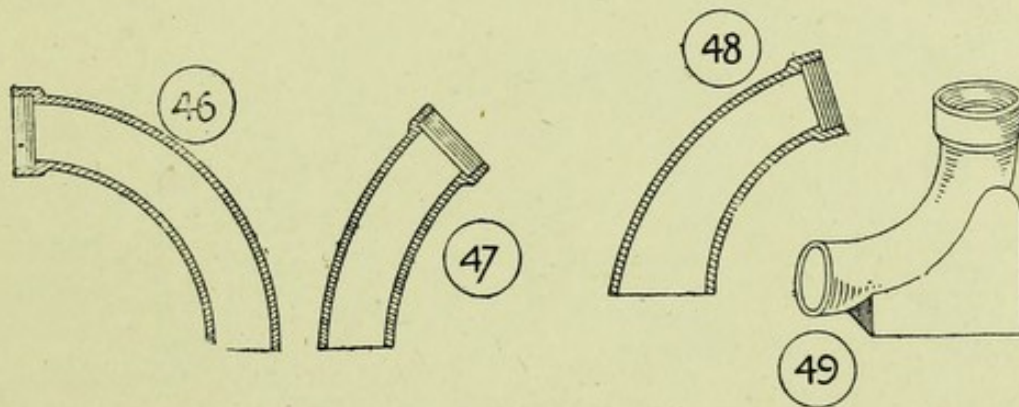

times called) are, therefore, introduced at such points as the architect considers necessary, so that the whole drainage system can be thoroughly overhauled if necessary. In a similar manner each separate section of a drainage system can be tested by the water test at any subsequent period to its installation. Figs. 50, 51, and 52 show such an inspection chamber. They should be built, where possible, in white glazed bricks laid in cement mortar, the wall of the chamber being one brick in thickness, with two courses of footings, a bed of concrete, one foot in thickness, being underneath the whole area of chamber and footings. The object of using glazed bricks is that the chamber can be kept perfectly clean, and can be cleaned periodically from the splashings which are certain to occur; being of white glazed bricks, and, therefore, impervious, all dirt is easily

seen and washed away. If expense prevents the use of white glazed bricks, salt glazed bricks may be used, and if these are too expensive, stock bricks can be used and rendered in Portland cement on the inside. The whole drain pipes are made to run into the manhole and then continued in the manhole by pipes of semi-circular section, or channel pipes as they are more usually called, as shown in figs. 50 and 52. These were formerly semi-circular in section, but in order to provide as deep a channel as possible 6 in. pipes are now made with a channel section of $4\frac{1}{2}$ in. deep, and 4 in. channels 3 in. deep. The advantage of these is apparent, there is less danger of overflowing than in the ordinary section. Channels of a section of three-

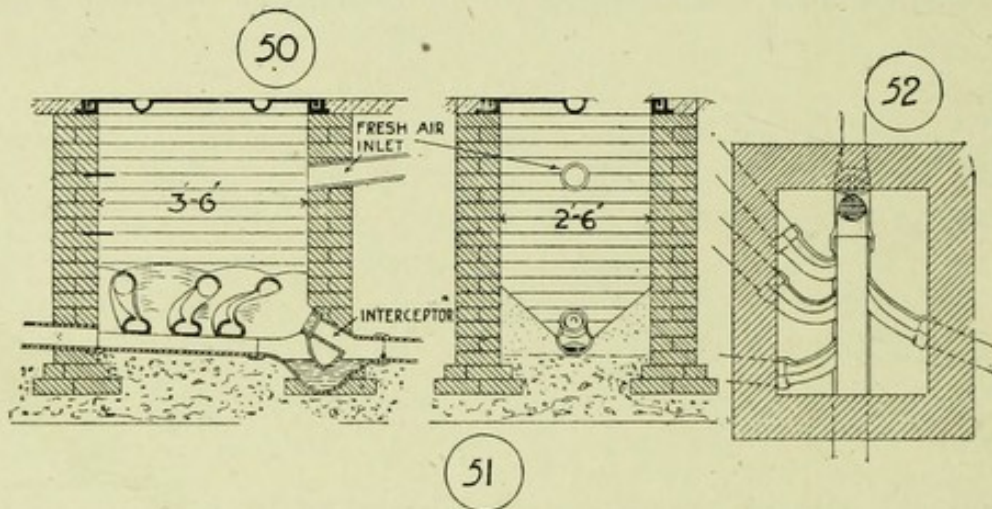

quarters of a circle are also made with the same object in view.

The junction between the circular pipe and the channel is generally made at the inside face of the wall; but for effecting a better junction between the two, Messrs. Broad have introduced connecting pieces of the shape shown in figs. 53 and 54, by means of which a better junction is obtained, the flat portion supporting the wall without unnecessary cutting away.

The branch drains enter at various angles, and are terminated, as before mentioned, with channel bends. These must be carefully set in the bed of cement concrete forming the floor of manhole, and must be so arranged with curved pipes as to direct the flow without splashing, and

with as little friction as possible. The pipes being set in cement, the space between them and the wall, or any other pipe, should be "benched" up as shown on cross section (fig. 51) in neat Portland cement, so that in case of splashing the sewage immediately falls back into the channels.

Disconnection of Drains.—We shall discuss the different kinds of traps later on, but we should state here that it is necessary to disconnect the house drainage from the sewer by the insertion of an intercepting or disconnecting trap on the sewer side of the manhole, as shown on the section of manhole which illustrates the Crapper disconnecting trap, fig. 50. Various makers have taken out patents for these intercepting traps. In the fig. 55 the one associated with Messrs. Broad's name is given. It is

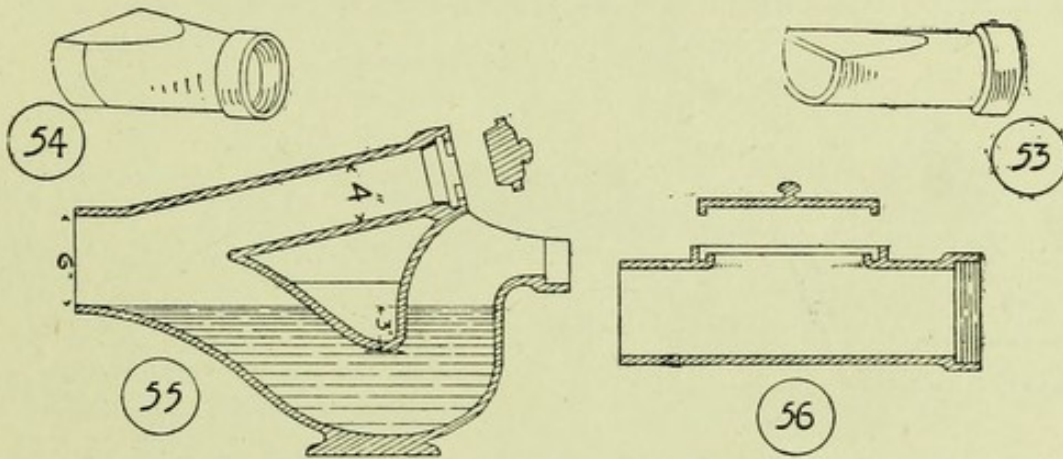

fitted, as are all intercepting traps, with an inspection arm, provided with an air-tight plug formed by a cap fitted with a Stanford joint, which should, before fixing, be lightly coated with grease dressing. When placed in position it can be wedged tightly home by the action of turning it. The inspection arm is useful in case of a stoppage occurring between the manhole and the sewer, as the cap can be removed and drain rods inserted.

Access to Drains.—A man can by the use of drain rods obtain access to any of the branch drains which discharge into the manhole or the main drain; and by the aid of the inspection arm of the trap the piece of drain between the manhole and the sewer can be cleared. This is the chief value of the manhole, though we shall see that

it is also used as a means of distributing a current of air through the drains; and although it necessitates a certain first cost in laying down a drainage system, yet the cost is saved many times over, because it is not necessary to break up the ground in various places in order to clear a stoppage.

Inspection pipes are occasionally used in the length of a long section of drainage where it is not considered necessary to go to the expense of an inspection chamber. One form is shown in fig. 56.

Manhole Covers.—The manhole should in towns and confined spaces always be covered with a perfectly air-tight cover. Figure 57 is an illustration of one made by Messrs. Broad. The section will explain itself; the cover is sent out fitted with india-rubber joints, and is also provided with

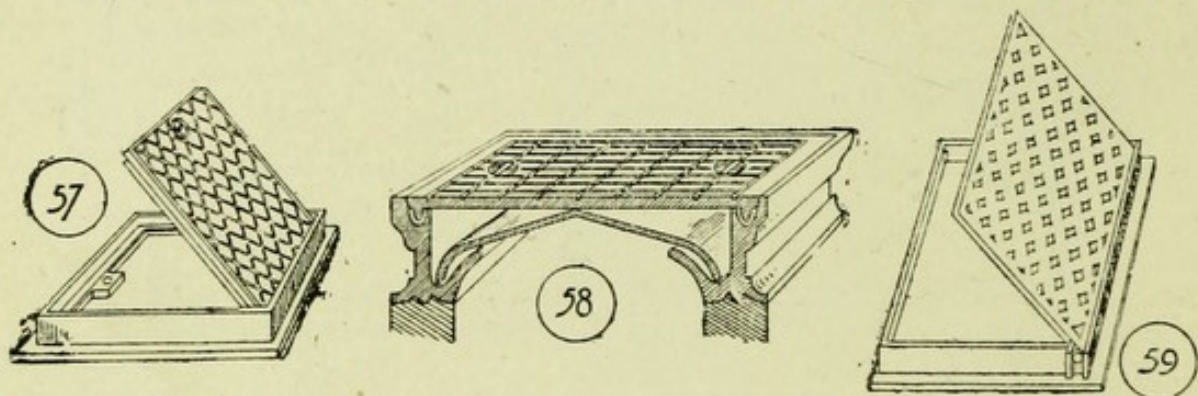

grooves to be filled with grease, soft soap, and sand; the covers are held down by four gun-metal screws. Another form which has been used of late is that shown in the accompanying illustration (fig. 58). In this, it will be seen, there is a double trap, an outer trap formed of an iron cover resting in a groove filled with tallow, fat, or soft soap. The inner or lower trap is formed of a dome-shaped cover, on the underside of which the moist air of the drains is condensed and collected into a trough at its bottom edge. This water seal is kept continually filled by the condensing action of the drains. It is patented by Mr. John Jones, of Chelsea. In the country and districts well separated from surrounding houses there is no necessity for an air-tight cover, but only an open grid (fig. 59), which prevents anything falling into the manhole. In this case the grid

forms the air inlet to the drains, and no inlet pipe is required.

Underground Drainage Traps.—Besides the intercepting trap previously mentioned, traps are required at the feet of waste pipes from **baths, lavatories, and sinks,** and at the feet of rain-water pipes; in fact, for every pipe excepting a soil pipe. These traps are generally known as “gully” traps, and are made in numerous shapes and sizes.

Traps are necessary in order to disconnect the vertical pipes attached to the sanitary fittings from the ground drains, and, provided these latter are properly ventilated, the water seal in the traps effectually accomplishes this disconnection, and a current of fresh air is enabled to pass

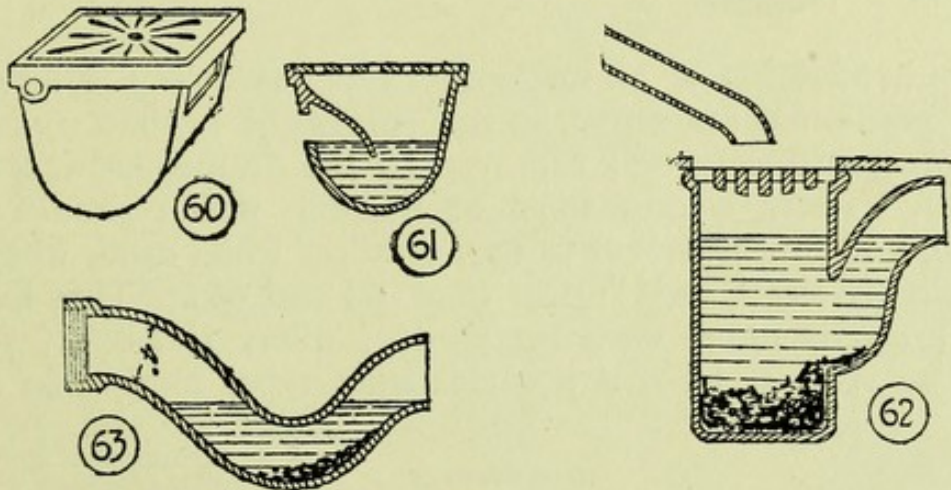

up the vertical pipes and to keep them sweet and clean. The waste pipes are arranged so that they discharge immediately over the trap, or they may be brought in behind, in which case all splashing is avoided.

Lip Trap.—Formerly the old “Lip” trap, figs. 60 and 61, was much in vogue; but it will be observed that there are corners in which sewage can be deposited; further, it was made in cast-iron, and having no socket, was difficult to connect properly with the drainage pipe. The trap shown in fig. 62 is a bad form of gully because it is not self-cleansing, but contains a considerable quantity of water, and the bottom portion forms a catch pit for the collection of filth. It should never be used.

Siphon or U-trap.—A kind of trap which was one of the earliest forms, and frequently used in underground drainage, was the siphon or **U-trap**, fig. 63. This is a bad form, partly on account of the quantity of water it contains, which is so large that an ordinary flush from a lavatory or water-closet would not empty it; partly on account of its non-cleansing qualities, the solids remaining in the bottom of the trap on account of the want of pressure of water.

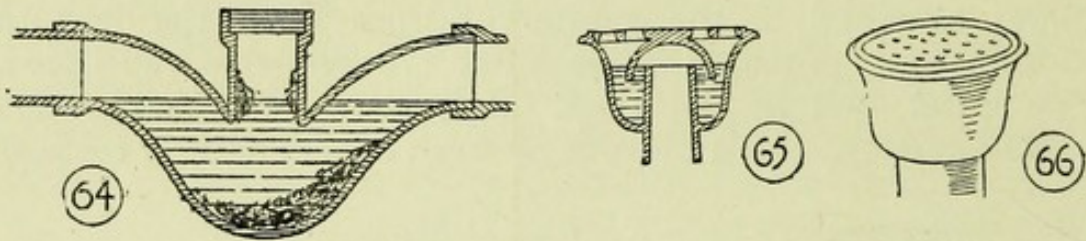

The introduction of an inspection pipe, as shown in fig 64, only made matters worse, as the solids got pushed up into the pipe, and were only removed by the drainage-rods from above. There is one word of warning which should be given, and that is, never to use, or allow to be used, what is known as the “**bell**” trap (figs. 65 and 66). This form was formerly much used for yards, scullery sinks, &c. As will be seen, it is of a non-cleansing type, and when the

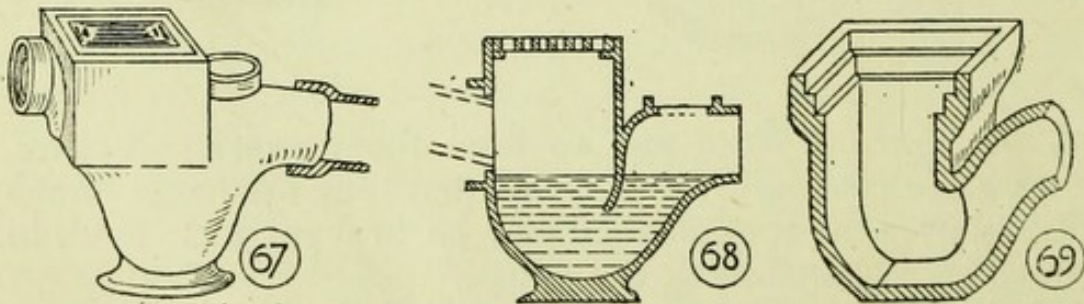

“**bell**” is removed, which is often done by servants knowing no better, there is no trap at all, but direct communication with the drain.

We may now proceed to discuss the best forms, which are designed so as to keep their seal, and to be self-cleansing as far as possible.

Gully Traps are now usually made of the form shown in figs. 67 and 68, which give an elevation section of a gully

trap for receiving a lead or iron rain-water pipe. In this case the rain-water is led into the trap under an iron grating in order to prevent splashing. Some of the vestries insist that it shall discharge over the grating, in which case fig. 69 illustrates the section of gully trap recommended to be used.

The waste pipes from baths and lavatories are treated in the same way.

Grease Traps.—The waste-pipes from *scullery* sinks bring us to a rather more complicated problem, namely, the prevention of the entry of grease into the drains. In order to effect this special traps are used. They consist of a trap large enough to collect the fat from the greasy water which is carried off by the sink waste. The number of patent

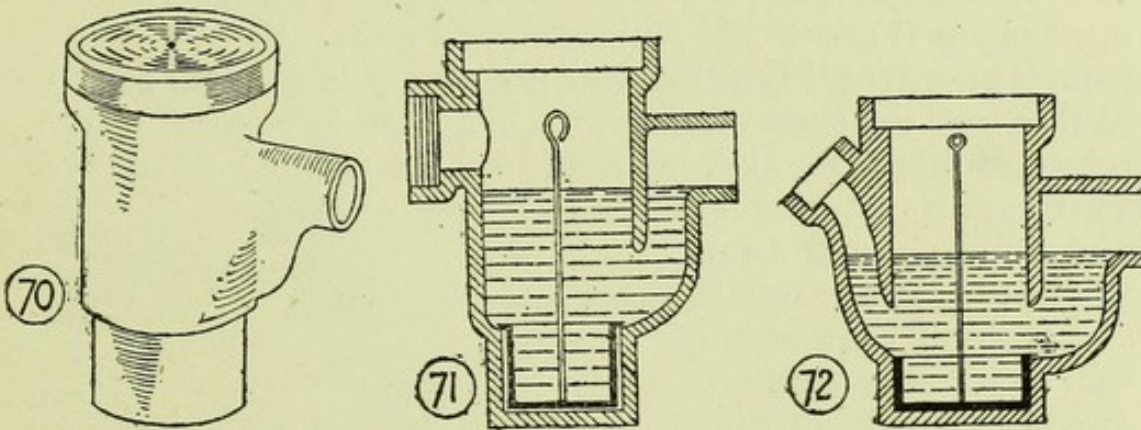

grease traps is legion, but illustrations of one or two are given. Dean's grease trap (also used in yards, &c.) is shown in figs. 70 and 71. It will be noticed that the sink waste discharges under the iron grid, which is level with the ground. There is a deep seal, and the grease naturally floating is thus prevented, to a large extent, from going into the drain beyond the trap. The bucket, which rests in the bottom of the trap, is provided with a long handle by means of which it can be raised at necessary intervals, and both the solid matters which have fallen into it and the grease which is floating on the top can be removed. Fig. 72 shows a grease-trap made by Messrs. **Winsor & Co.**, in which a still wider space is left for the congealed grease.

The great objection to all grease traps is that they become

little cesspools if not frequently cleaned out. In large country mansions and hotels they are necessary, as the amount of grease and dirt discharged from a scullery in such cases is very great. They should then be placed under supervision and be cleaned out two or even three times a week.

In ordinary dwelling-houses, it is doubtful if grease traps are desirable; and considerable diversity of opinion exists among authorities on this subject.

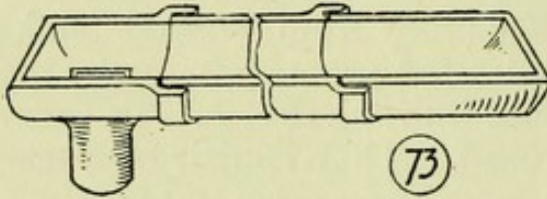

Probably the best way of treating the wastes from sinks is to follow out the recommendations of the Local Government Board, that all wastes should discharge over an open channel connected with a trapped gully. Fig. 73 shows what is known as "**Duckett's**" self-cleansing channel gully; in this case the greasy sink water has time to congeal while passing toward the gully trap, and can be cleaned off daily.

Further, it is visible, and if not cleaned away would give rise to smells which would draw attention to it. The ordinary grease trap falls in with that condition which is always insanitary, viz., "out of sight, out of mind," whereas the discharging over an open channel obviates this difficulty. Fig. 74 shows an illustration of **Broad's**

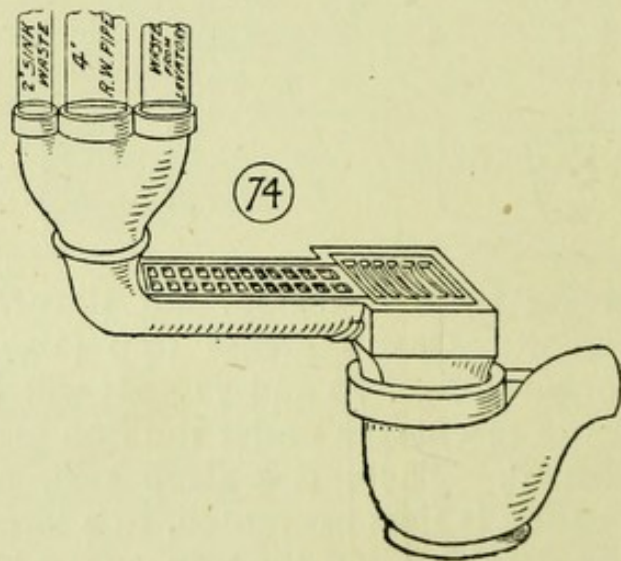

channel shoe and reversible gully trap, in which the waste water from a bath and lavatory, a rain-water pipe, and also a sink waste, is all discharged by means of a three-way head into an open shoe, and thence to the gully trap. In this case an iron grid may be used, but it is probably better left wide open, although if it is also made to take the surface water from a yard some form of grid

is necessary to prevent *débris* finding its way into the drain.

Generally speaking, we should say that every gully should be made to do as much duty as possible, as the number in use can thereby be reduced. The position of the rain water and waste pipes decide where they are to be fixed, and the paving may also be laid so as to make them do duty for surface drainage. If possible, no surface gully

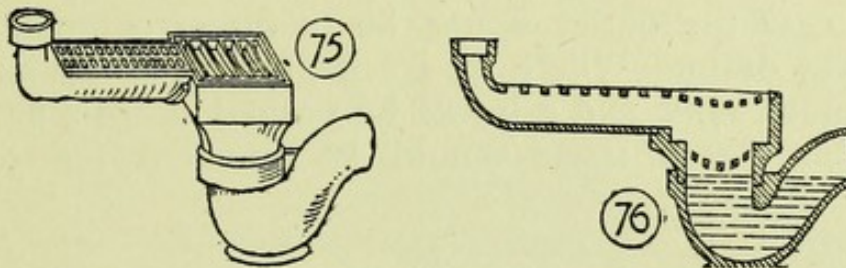

should be without a waste pipe discharging into it, so as to keep it sealed during dry weather. In positions where many leaves fall or much waste-paper is blown about, gullies should be covered with wire cages to keep the litter off the gratings.

Figs. 75 and 76 show a view and section of a similar arrangement to take simply the 2-in. waste from a sink.

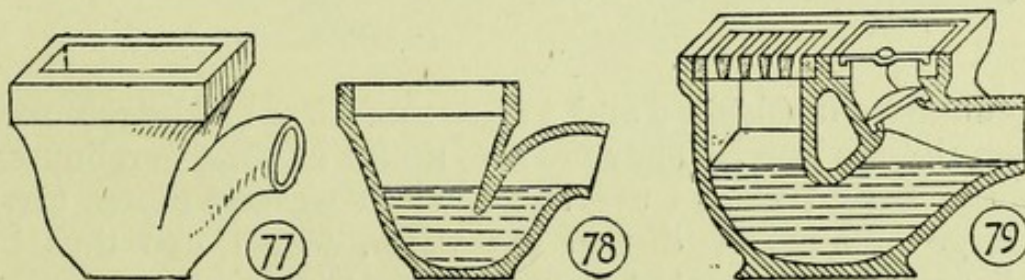

Surface Drainage.—Yards, areas, and other open spaces are drained in a similar manner, by having their surfaces laid to falls. Figs. 77 and 78 show in elevation and section a **yard gully** as used extensively by the London School Board. It has a flat bottom, and should rest on a bed of concrete. In this case no grid is used, the surface-water being led direct into the trap, the water of which is therefore visible from above. It is made with either P or S

outlets, to suit the inclination of drain. Beside the traps enumerated above, many are made with inspection eyes, so that if a stoppage occurs it can be easily removed by means of drain rods. It will be readily seen that to pass a drain rod from above, through the curved space forming the trap, is almost impossible. Fig. 79 shows an air-tight stopper on the drain side of the trap, which can be taken out and the drain rods inserted into the length of pipe. There is always, of course, the danger that this may become unsealed, in which case the outlet would be in direct communication with the drain. Where it is likely that a considerable amount of sand and grit will be washed down a gully it is advisable that a space should be provided for solids to

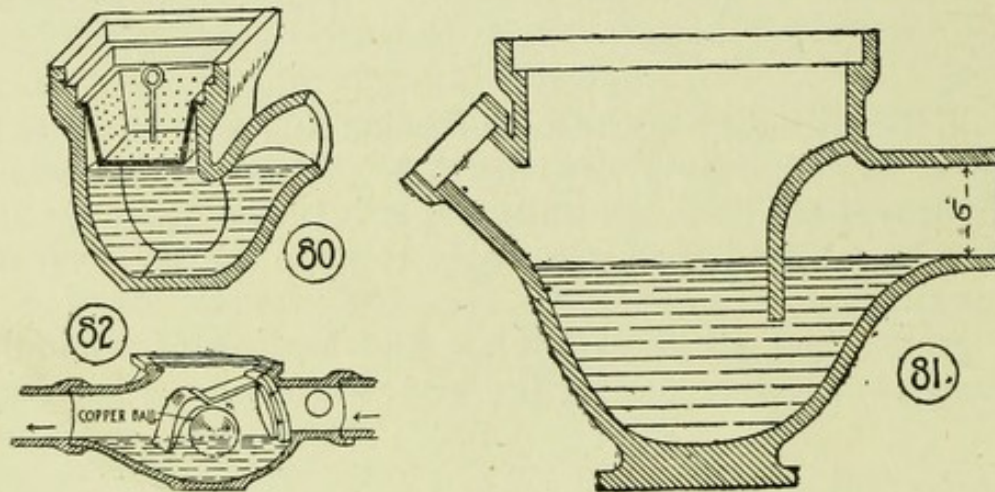

accumulate in (figs. 70 and 71), so that these can be removed from time to time. They are also useful in large warehouses, in the basements, as the latter, when washed down, carry a large amount of dirt in the water, which can thus be collected and prevented from entering the drain.

In **stables** there is the same difficulty to contend with, and Messrs. Broad's stable gully (fig. 80) is designed to intercept particles of straw which may have passed through the top grating, the perforated bucket below lessening the possibility of the drain becoming choked. In the Express Dairy Company's cow-houses there are no gullies inside, but they are placed outside, the drainage being led to them in open white glazed channel pipes covered with strong galvanised iron gratings. When cleaning the houses the

gratings are lifted, taken out, and washed, while the stalls, gangway, and channels are cleaned with a hose pipe.

Various other gullies have been designed, and one of them is the **flushing gully** of the form shown in fig. 81, often used for sink wastes. It is connected at the back with a flushing tank holding some thirty gallons which discharges automatically from time to time. Such a discharge undoubtedly helps to keep the drains clean.

Before passing from this subject, attention should be drawn to the prevention of what is known as "back flow," that is, the return of sewage from the sewer back to the house drainage. This is only liable to occur where the main drainage is not of a sufficient depth to secure immunity from floods. Fig. 82 shows a method of preventing this. The diagram explains itself. A copper ball floats in the intercepting trap, and in the event of any back flow effectively stops up the opening on the house side of the drain. The patentees of this trap are Messrs. G. & F. Couzens.

The traps here dealt with are those which are fixed in the ground outside the building in the system of house drainage. Traps used inside the building are treated in a later article.

CHAPTER VII.

DRAIN VENTILATION, INCLUDING SIPHONAGE AND TRAPS.

DRAINS, like human beings, require fresh air in order that they may remain thoroughly clean and harmless. It is here proposed to go shortly into the reasons for this necessity, because, as we shall see, the ventilation of drains is not only necessary in order to keep them wholesome, and for the prevention of standing air, but also to prevent the siphonage of traps and the entrance of sewer gas into the house. These are most important points, and are often ineffectually coped with in old houses. Our next section is "sanitary fittings," and before dealing with these this seems a fitting place to consider the subject of siphonage, as in considering the **fittings** we shall take care to see that the principles enumerated are applied in their construction.

The principal objects to be sought in ventilating drains are, to prevent bad air accumulating, as mentioned above; but if any such does accumulate, to so construct our system that it is immediately led away to the outer air, at such a point as to prevent it being drawn into the house through the windows or other openings.

It is necessary, therefore, to produce throughout the whole system a current of fresh air which shall be continually moving. In order to produce this current we have to think of two natural phenomena. The first of these is the fact that air when heated expands and rises. Now, every drain is laid to a fall, and the vitiated air which naturally accumulates therein, owing to chemical decomposition, is warmer than the atmosphere and its specific gravity is less; it therefore has a tendency to rise to the higher end of the drain. If there is an outlet at this latter end, and an inlet for fresh air at the lower end of the system of drainage, a current is at once produced which, in

ordinary circumstances, will be effective in preventing the stagnation of noxious gases.

Another factor which is useful in ventilating drains is the fact that air in motion is lighter and more rarified than air which is at rest ; therefore, if a ventilating pipe is carried up well above the ground, if possible to the ridge level of the house, a self-acting exhaust shaft is obtained, because the air at the top end of the pipe is more in motion and less dense than that at the lower end, and hence an upward draught is produced. One system, therefore, which is generally adopted is to have a short inlet pipe at the lower extremity just before the connection with the main sewer, for the admission of fresh air, and a long outlet pipe at the head of the drain, and off each branch drain (when it carries the drainage from a water-closet or is of any considerable length), carried as mentioned above to such a height that it cannot be a nuisance. The outlet pipe may be either finished with an open end, fitted with a galvanised iron wire cage to prevent leaves falling down or birds building in it, or it may be fitted with any of the numerous up-draught cowls, some of which certainly do tend to increase the upward current of air, and many, if they do not effect this, at least prevent a down-draught.

Many architects, however, prefer the open pipe fitted with a wire cage which, as explained, should be an exhaust in itself, under most conditions of the atmosphere.

As to the size of the outlet pipe, it should be of the same diameter as the soil pipe of which it is a continuation.

An **outlet pipe** which is not a soil pipe should not be less than 4 in. diameter, and should be as far as practicable without any bends in its entire length.

The **inlet pipe** is usually placed with its opening about 6 ft. from the ground. It is kept as far away as possible from any door or window opening of the house, and is generally fitted with a mica flap valve so placed that it only allows air to enter, any back current of air from the drain causing the valve to shut. This inlet pipe in town houses is taken into the manhole nearest the sewer, by which means the fresh air is admitted into the lower pipes of the drain and can find its way up all the sections of the system.

The inlet pipe should have a sectional area equal to the sum of the various outlets of the main and branch drains in order to be effective. Very often a 4-in. inlet pipe is considered sufficient for a large system, whereas a little thought ought to show that it must be perfectly inadequate.

It is important that the inlet and outlet pipes should be made of some material which will not decay, and so clog up the pipe, and in which a perfectly air-tight joint can be made. For this reason it is doubtful whether iron, even when galvanised, should be used, as if there is any defect in the galvanising, rust will form, and eventually collect in the bottom of the pipe and completely choke it up. A case quite recently occurred in a hospital in which the rust had so accumulated as to completely stop the circulation of the air, and the drains had to be opened out to find the defect, when half a pail of rust chippings was extracted from the bottom of the ventilation pipe. It seems best, therefore, that both inlet and outlet pipes should be made of stout drawn lead pipes of not less than 8 lb. lead (*i.e.* lead weighing 8 lbs. to the superficial foot). Lead soil or ventilating pipes should be protected up to 6 ft. from the ground by a galvanised sheet-iron shield to protect them from injury.

In country houses, with the inspection chamber at some distance from the house, the drains are best ventilated by covering the inspection chamber with an open grid, thus admitting as much air as possible (see fig. 59 in a previous chapter). No air-tight cover is necessary as in towns, where the inspection chamber is often in a front area, or even in some cases unavoidably placed in the basement itself.

The system described above, although the one usually preferred, yet has its defects, which can now be briefly pointed out.

Under ordinary circumstances, when no discharges are taking place from water-closets or other sanitary fittings, the upward current of air mentioned is not disturbed, but let us consider what takes place when the contents of a water-closet basin are suddenly discharged down a soil or waste pipe. When this occurs a downward current of air is produced, which upsets all the arrangements of inlet and

outlet; that is to say that during certain times of the day the ventilation system is nullified. Beyond this, it acts in a dangerous way on the whole system, by forcing the air in the pipes downwards and forcing the bad air through any defects in the fittings of the mica valve of the inlet pipe (which is always liable to be imperfect). If this pipe happens, as is often the case in London, to be near a door or window, the foul air emitted will probably find its way into the house. If the inlet pipe is at a sufficient distance from the house no harm will result.

In this case, therefore, the safest means of ventilation would be to carry both inlet and outlet pipes above the roof level, and, if possible, causing one or other to be more exposed than the other in order to cause an up-draught. By placing one on the north side and the other on the south side of the house, the air in the latter, being warmer, would naturally rise and draw the foul air from the whole system. We should also make use of the current of the sewage which would draw the air after it, and would therefore constitute a mechanical power in aid of the system.

Siphonage.—Beyond the necessity of well ventilating drain pipes to keep them clear of foul air, there is another reason which will render it necessary here to make a few remarks on the effect which a sudden discharge from the water-closet or other fitting has on the water seal of traps.

This leads us to the consideration of the mechanical principle of siphonage, which must be thoroughly understood by the student. The siphonage (*i.e.*, the emptying the trap of its water) may occur in two ways, which will be best explained by reference to the fig. 83. This shows an ordinary S trap filled with water. If a discharge of water occurs through the trap itself which is sufficient to fill the sectional area of the pipe, the trap would either remain emptied or a vacuum would be left at the outgo of the trap at A, but nature abhors a vacuum and the pressure of the atmosphere at B being greater than at A, would cause either

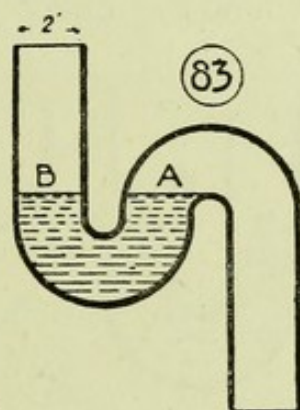

part or the whole of the water to be forced out of the trap, which would be useless as a preventive for the inlet of foul air; or, in other words, the trap would be *siphoned*.

The water seal of the trap may also be interfered with in another way, such as when two closets are planned one above the other and discharge into the same down pipe C (fig. 84). In this case the air following the discharge down the pipe would also draw the air in the portion AD along with it, thus lessening the pressure on the water in the trap at A, which would cause it to become unsealed by the pressure of the atmosphere at B.

The student can easily satisfy himself on all these points by means of model traps made of glass and joined with glass down pipes by means of indiarubber rings, when the effect can be readily seen.

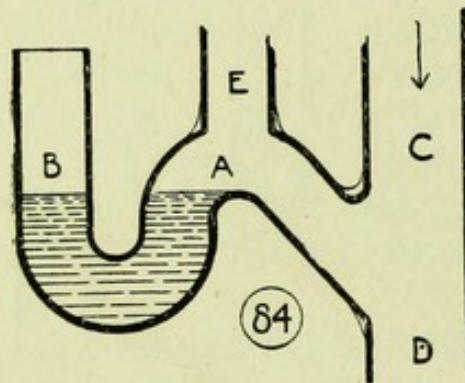

Both of these causes of unsealing may be prevented by ventilating the trap at its outgo by means of the ventilating pipe E (called the anti-siphonage pipe) which should, in order to be effective, be of the same diameter as A, and should be carried up higher (generally about 6 ft.) than

any of the branch pipes AD, when it may be taken into the ventilating pipe CD, which in turn is carried above the roof level. By the introduction of Mr. Hellyer's anti-D traps, described later on, the evils of siphonage were much reduced.

Traps.—The use of traps in a drainage system is imperative, and the principles upon which they should be constructed may be briefly outlined. Earthenware traps placed underground have been already dealt with in a previous article.

A trap in its simplest state is merely a bend in a pipe which retains water and prevents air from passing through it. The illustration (fig. 85) shows a simple S trap, the space between E and F being the water seal. The depth of this seal is important. It should never be less than

1½ in. But a water seal alone is not sufficient to prevent the passage of gas through a trap. The reason of this is that water will absorb such gases and give them off again; for instance, ammonia has been found to pass through the water of a trap in a quarter of an hour. It is necessary therefore, that the water in a trap should be changed tolerably frequently, and also that the trap itself should be ventilated on its upper side, so that noxious gas may be immediately led away and not press against and saturate the water of the trap. A trap may also be rendered useless by means of evaporation. Ventilation of a trap is required,

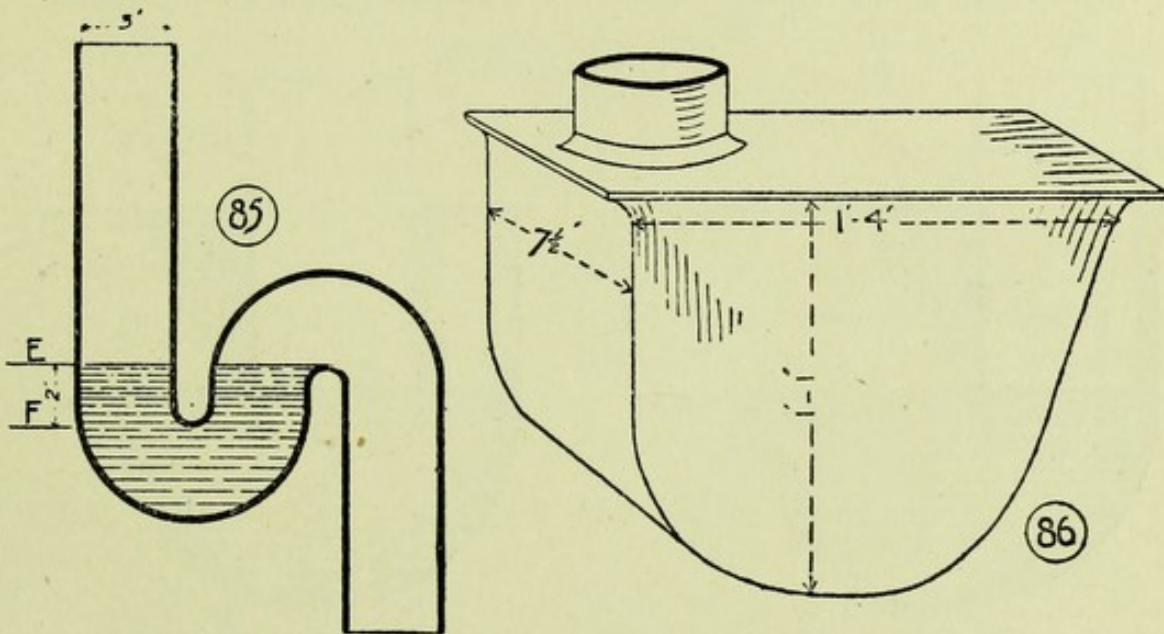

therefore, in order to secure its efficiency as a trap, as well as for other reasons, which we shall touch on presently.

We give a selection of various types of traps used in the sanitary fittings of a house. Those in the underground drainage have already been discussed under house drainage. They should all be designed so as to be as nearly as possible self-cleansing, to have an effective seal, and to be free as possible from all angles that may retain filth.

Some bad types which do not fulfil these conditions are first given. The "**Bell**" trap, which was formerly used for scullery sinks, has been already explained, and its defects pointed out in regard to yard drainage. The old **D** trap was probably one of the worst kinds ever invented, and was

so called from its shape. Fig. 86 shows a view of one of these, and figs. 87 and 88 sections of two different kinds. The "dip" pipe is projected into the water of the trap about $1\frac{1}{2}$ in. In fig. 88 it will be observed that this pipe is some distance from the back of the trap A, where the soil congregates and adheres to the trap. Fig. 87 is a less objectionable section, but even in this form the soil clings to the sides. The trap is full of corners for the collection of filth, as is evidenced by examining any old D trap which is taken out of a house. If the dip-pipe becomes eaten away the trap itself is entirely destroyed.

Some of the better forms of traps are now enumerated.

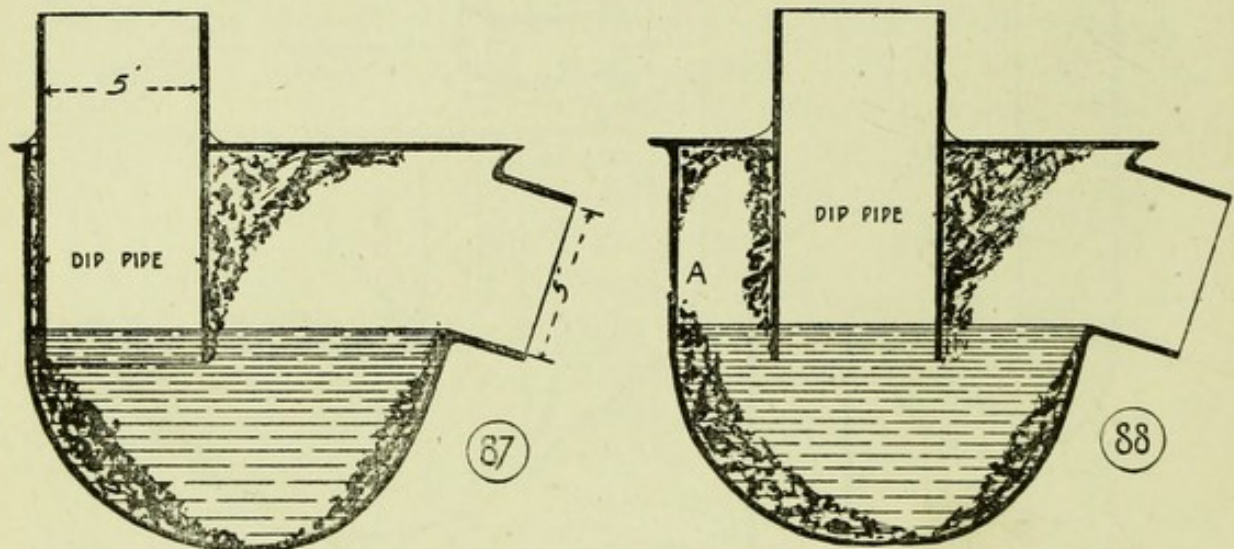

These are generally called after the letter they represent. The S trap is shown in fig. 89. It is made of stout drawn lead, generally of 8 lbs. to the superficial foot. It will be observed that it is useful for a vertical waste, and is made in sizes of $1\frac{1}{4}$ in. to 4 in. internal diameter. The smaller kinds are fitted with a screw inspection cap at A as shown, so that in case of stoppage they can easily be cleared out.

The P trap (figs. 90 and 91) is useful for cases in which the waste is horizontal for a certain length, and is constructed similarly to the S trap. Both the P and S traps are largely used to form the traps of baths, sinks, and lavatories. In such cases they are made with an enlarged mouth. This is necessary in order that the trap and waste

pipe may be thoroughly flushed out, the full bore of the discharge not being interfered with by the plug and grating from the basin.

These traps are made of the ordinary circular section.

An improvement was, however, made by Mr. Hellyer in

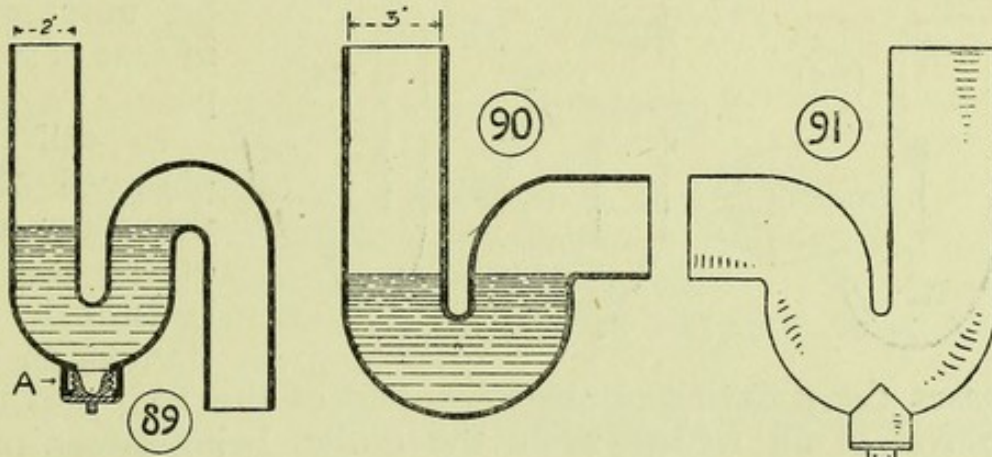

introducing his well-known anti-D traps. These were introduced to prevent the water of the trap being driven out by the momentum of the water discharge, and also to secure the thorough scouring of the trap itself. By a series of experiments Mr. Hellyer found that this could be obviated

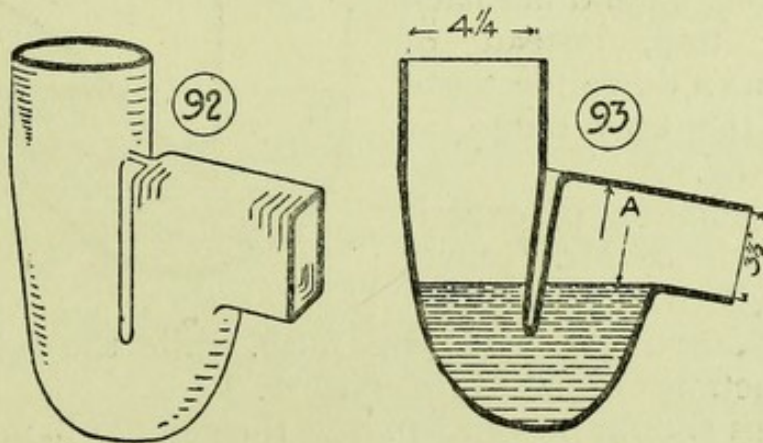

by so shaping the trap that the water-holding portion is contracted and the outgo is larger and square in section. This is useful in preventing siphonage. This square outgo has, however, in some cases been found to collect filth in the angles of the square section. Several illustrations, figs.

92, 93, 94, 95, and 96 show the principles on which these are designed. These traps have a water seal of $1\frac{3}{4}$ in. The larger size is used for water-closets, and the smaller ones for the wastes of baths, lavatories, and sinks. The smaller ones are generally provided with an "inspection cap" which can be unscrewed in case of stop-

page.

It will be observed that the water-way of the trap is reduced in size, which in-

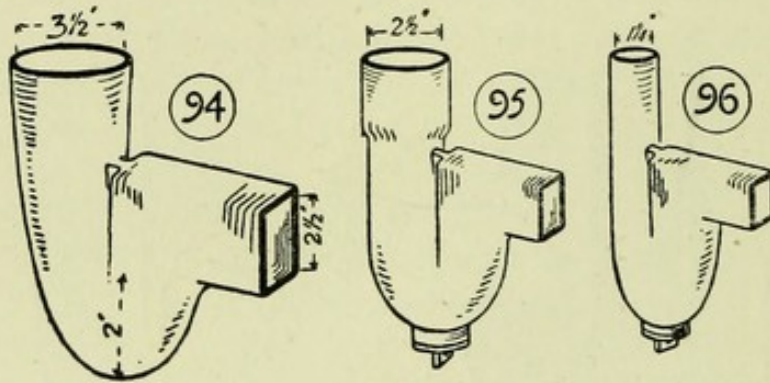

creases the scouring of the lower part of the trap and the removal of all refuse, while the outlet, being larger, prevents the pipe filling full bore and causing siphonage. Another advantage which the anti-D trap has over such a section as fig. 97 (which is a bad form) is that the water rushing through the trap would have a tendency to hit the upper edge of the outlet at fig. 93 and fall back into the trap, instead of being drawn down the waste pipe by the easy outgo, as shown in fig. 97.

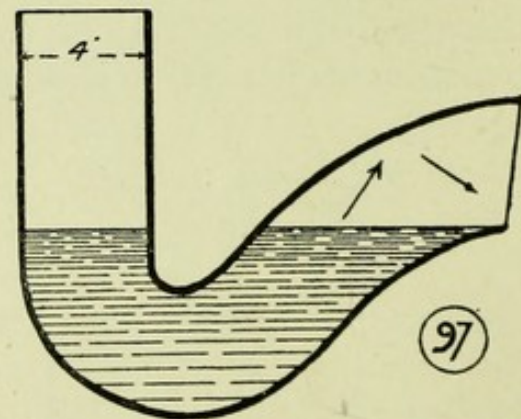

In a number of experiments made by Mr. Hellyer the anti-D trap was completely cleaned out with one flush, while the round-pipe traps sometimes required two flushes.

All traps should be ventilated at their outgo if more than one fitting empties into one waste pipe, and even with only one fitting it is best to ventilate it. Some of the experiments made by Mr. Hellyer are interesting as showing the necessity of having the traps ventilated.

CHAPTER VIII.

SANITARY FITTINGS.

HAVING in our last article referred to drain ventilation and siphonage and some of the more usual traps in use, the way has thus been prepared for the discussion of the various sanitary fittings which are used in the house and the general treatment of such fittings.

This section may be conveniently tabulated into the following sections:—

1. *Preliminary Remarks.*
2. *The Various Types of Water-closet Pans, &c.*
3. *Flushing Cisterns and Water-waste Preventers.*
4. *Soil Pipes and their Ventilation.*
5. *Baths and their Wastes.*
6. *Lavatories and their Wastes.*
7. *Urinals.*
8. *Sinks and their Wastes.*

I. **Preliminary Remarks.**—Sanitary fittings of all kinds should, where possible, be fixed against an external wall, so that the apartment in which they are placed may be capable of thorough ventilation, and also that the fittings themselves and their wastes may be easily overhauled and repaired in case of necessity, so avoiding the danger inherent with internal soil pipes and the connection of the house air with the drainage system.

The planning of water-closets in relation to the other parts of a house has been already dealt with in a former article; but we may emphasise the necessity for making the walls of rooms in which sanitary fittings are placed of non-porous materials. For instance, the floors of bath-rooms, lavatories, water-closets, are best made of tiles,

terrazzo paving, or other non-absorptive materials. The walls may be either of glazed tiles, from floor to ceiling, or merely as a dado with the upper part plastered and painted or distempered. A method often employed is to have flooring laid to a fall towards the outer wall, so that the floor can be scrubbed down and the water led by a small waste-pipe into a rain-water head. In America, where the floors and walls of bath-rooms and lavatories are nearly always tiled, the evil effects of overflows to the fixtures are abolished, the overflowing water falling on to the floor and running off by the pipe mentioned.

Every apartment should be well lighted, and with the whole window constructed so as to open, and should, where possible, be disconnected by a ventilating lobby from the house. Abundant light is an enemy to dirt of all kinds. Where there is light there is, as a rule, cleanliness, and this brings us to an important point, and that is the casing of fittings. One of the greatest advantages in modern sanitation has been the tendency to abolish what are known as "casings," that is, the wooden enclosures or framings which were formerly considered necessary as an envelope to hide the actual water-closet pan and bath, &c.

In a healthy dwelling casings should be avoided, as they simply harbour dirt and vermin, and answer no useful purpose whatever. One should be able to see all round a sanitary fitting in order to ensure its cleanliness, and unless one can do so it can scarcely remain sanitary.

In the more recent examples of superior plumbing this is now exemplified by the use of pedestal closets and what are called "Roman" baths, *i.e.*, rolled edge baths without enclosures. Lavatory basins are often carried on nickel-plated brass brackets, all the pipes being in sight.

To the student in London a visit to the Parkes Museum in Margaret-street, and to the Architectural Museum, King's College, will be of the greatest assistance, because he will see there models of appliances of every kind.

2. The Various Types of Water-closet Pans, &c.

—It goes without saying that the water-closet is the most important of sanitary fittings, and is that to which the attention of reforming sanitarians has been earnestly

directed. A water-closet fitting consists of a basin and a trap, and its efficiency depends on the way these are constructed so as to answer certain requirements of cleanliness and suitability.

Before dealing with the various types of basin, let us state briefly what is required in each. The basin, it is evident, should be of such a shape that no part is liable to be soiled by the excreta falling on the sides, and every part should be thoroughly scoured by the flush of water. It should be made of glazed stoneware, a perfectly impermeable material, preferably finished white, and so formed that it retains a sufficient depth of water from the after-flush to receive the excreta, and so prevent the fouling of the bottom of the basin. This latter point is of importance because it is found that if the fæces are thoroughly coated with water before being discharged into the soil pipe, there is less likelihood of the fouling of the interior of the pipes.

The apparatus should, if possible, have no working part which can get out of order; and, lastly, as mentioned previously, should not be enclosed in woodwork, which forms a receptacle for dirt and filth of all kinds.

The water-closet trap should be of a simple self-cleansing form, without angles or other obstructions, fixed above the floor so as to be easily accessible. It should have a minimum water seal of $1\frac{1}{2}$ in. to 2 in., and protected against siphonage (as referred to in the article on "Drain Ventilation") by being ventilated at its outgo.

In dealing with the various forms of closet, we shall observe that the basin and trap are sometimes made of the same piece of earthenware, whereas, in other cases, the trap is made separately of lead or iron. With a separate trap, there is the advantage that in case of damage to a water-closet pan it can be repaired without opening up direct communication with the drains.

We do not propose to take up much room by dealing with insanitary forms of water-closets, but no article would be complete without reference to a few which have been in use in the past; and by looking at the reasons for which they have been discarded, we shall perhaps be better able to understand the sanitary points of the better forms.

Of all insanitary fittings the old **pan-closet** (fig. 98), with iron container (A) and lead D trap (B), was undoubtedly one of the worst. A glance at the illustration will show that in no respect does it fulfil the requirements as set forth at the beginning of this chapter. It takes its name from the hinged pan (C), which swings backwards and forwards by means of the closet handle. As will be seen, this pan requires a space to swing in ; this was known as the "container," which quite acted up to its name, as it formed a receptacle for the excreta which made it neither more nor less than a small cesspit. Even when the closet was flushed the water could not succeed in reaching a large

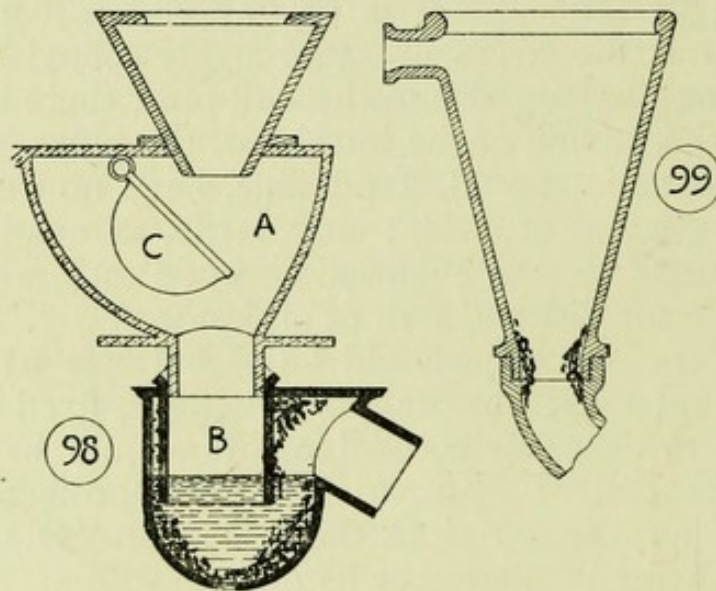

part of the container, which, therefore, was never cleansed, but became fouler and fouler from the splashings of the pan ; and the gases, of course, found their way into the building whenever the pan was let down to clear the closet of excreta. This was in itself bad enough ; but, in addition, the apparatus had attached to it what is known as a **D trap**, so called from its shape. It will be seen at once that it is a most insanitary form of trap, with large flat surfaces and corners ready to intercept and collect the excreta.

Being, as a rule, unventilated, it formed a collecting space for foul gases, which, joined to those in the container, were ready to pour into the house whenever the pan was lowered.

Probably only those who have taken out a pan closet with its D trap will realise how insanitary and dangerous it rendered the house, and the necessity of at once removing such a form of closet from old houses even now constantly arises.

The **long-hopper** closet, fig. 99, is another form which was somewhat largely used. It is seen that it cannot be a sanitary fitting; the water was usually introduced by means of a spiral flush, which only half-cleaned the pan, and the latter was kept continually soiled because the water area at the bottom of the basin was not of sufficient capacity to catch the soil.

Various developments have, however, taken place, which are dealt with later on.

The **wash-out** closet, fig. 100, secured the favour of

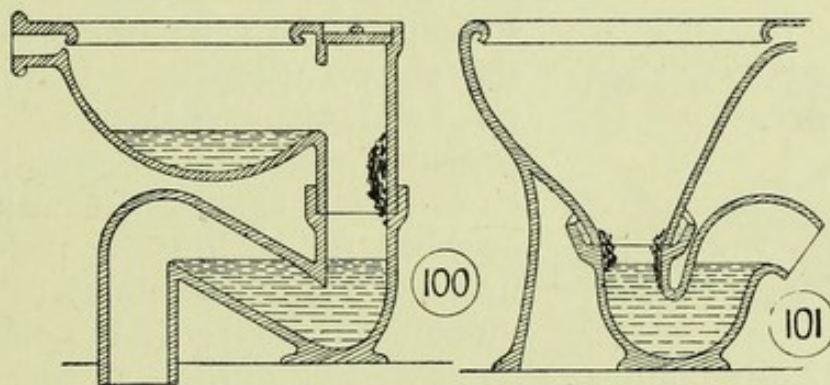

sanitarians some years ago, but although met with in many houses, they are condemned by most as insanitary, for reasons which a glance will explain.

The water at the bottom of the basin is, as a rule, too shallow, and the excreta, instead of being forced straight down the trap into the soil pipe, is dashed against the outgo, which is in consequence fouled, and then has to find its way down the trap, the value of the momentum being lost. Enough has been said to show the insanitary qualities of the foregoing types, and we can now proceed to deal with types which are considered of a more improved kind.

A step in the right direction was made when the long hopper form was changed to the short hopper, a section of which is given (fig. 101). It will be seen that a flushing

rim is obtained which will ensure the basin being thoroughly flushed, but the water area at the bottom is only about 4 in. in diameter, and the basin would practically be fouled every time it is used by the excreta falling on the sides.

This brings us to the simplest and probably the best form of closet for ordinary purposes, which is known as the **wash-down**, and a form of which is now ordinarily used for general purposes (see fig. 102).

It is an improvement on the short hopper form. It can be either made in one piece, with the trap attached, or in two pieces, the trap being separate; the latter being best, because the pan can be repaired without opening up communication with the drain.

Among the many advantages which this closet possesses are its simplicity and cheapness, which are most important factors. It is usually made of a pedestal form, spreading

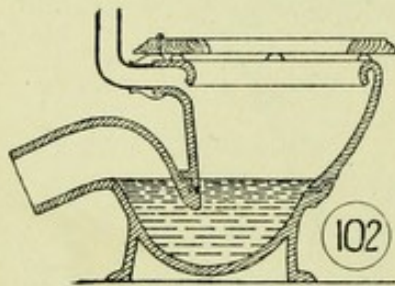

sufficiently to carry the weight of the person using it. It requires no "mahogany enclosure," but is provided with a lift-up seat, hinged so as to fall against the wall, thus enabling the basin to be used as a urinal. The outside may be ornamented in low relief in colours or

kept perfectly plain, so that any speck of dirt can be at once removed. It will be observed that the water area is as large as possible, which prevents the fouling of the basin; and it is also deep enough to submerge the fæces, and thus prevent the apartment being filled with noxious odours. The former is an important point, as if the fæces fall on the dry side of the basin, they adhere, so that two or three flushes are sometimes necessary to remove them. The flushing rim is of sufficient size and form to thoroughly scour the inside of basin. The trap in this case is a P trap, with a water seal of 2 in., and the outgo is so arranged that the joint is under water, so that in the event of any defect arising it is at once made apparent.

The joint between the lead soil pipe and the earthenware trap is generally the weakest part of this form of water-closet, and special care must be taken to render this

perfectly airtight. The London County Council have issued regulations on this joint, and the vestries also insist on it being made as follows: In connecting a lead pipe to earthenware, a socket is formed on the lead pipe by means of a plumber's "turning pin." The end of a brass collar or ferrule fits into this. Tallow is then rubbed over the parts on which solder is to be placed, and then molten solder is poured around the joint and "wiped" into shape by help of a cloth. The brass ferrule is then jointed to the earthenware by means of a ring of gaskin (hemp) and neat cement is then run in and wiped round. This fills in the grooves and makes a thoroughly waterproof and air-tight joint. Pathogenic germs are prone to linger in the hemp, and many authorities therefore advocate the use of other material.

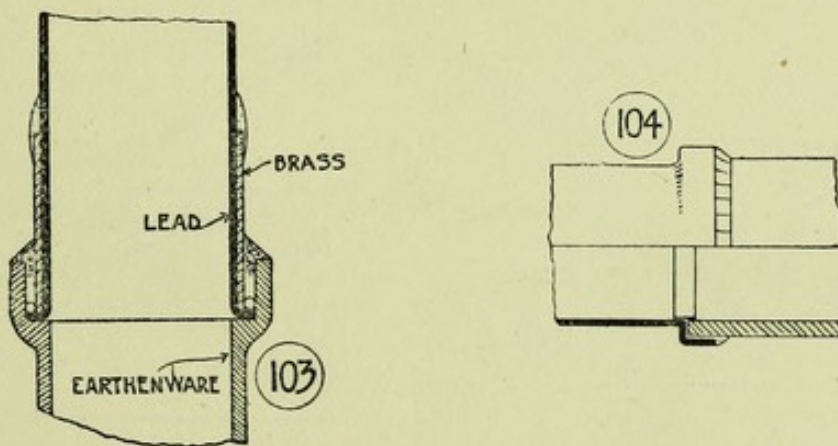

This is one of the best ways of forming a reliable joint between lead and earthenware, and is insisted on by the sanitary authorities. A section is shown in fig. 103.

The old method of a red lead joint between earthenware and lead is generally rendered defective by means of the contraction and expansion, allowing direct communication between the drainage system and the house.

Another means of forming this connection is known as the "metallo-ceramic" joint (fig. 104). This is an invention of Messrs. Doulton, and it has been received favourably by the authorities. On the pottery only of the closet, before being sent out, a short piece of lead pipe is fused by a patent process, and the entire incorporation of the pottery and metal at the point of junction is effected.

The result is considered perfect, and as every joint is tested up to the pressure of a 45-ft. head of water, it must be admitted that it forms a very excellent joint. This also possesses the advantage of the closet being perfectly ready to be connected with the soil pipe by an ordinary wiped joint.

Fig. 105 shows Messrs. Doulton's "Simplicitas" closet, which has found much favour among architects. An anti-siphonage pipe (S) is shown and it is usually 2 in. in diameter, and by the London County Council regulations it is placed not less than 3 in. or more than 12 in. from the highest point of the trap. There is a tendency among manufacturers not to follow out this rule, but to place this anti-siphonage connection less than 3 in. from the crown of

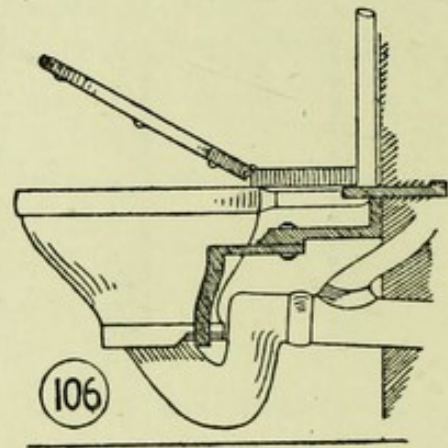
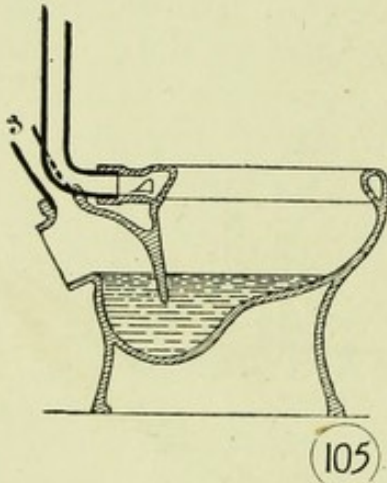

the trap. The use of anti-siphonage pipes has been already dealt with as necessary to prevent siphonic action, and thus destroy the water seal. They are also useful in ventilating the upper part of the trap, thus preventing foul air from pressing against the water seal. The illustration shows the flush pipe, which is connected with a siphon-flushing cistern or water-waste preventer. It is usually made of $1\frac{1}{2}$ in. internal diameter and connected with the flushing rim by means of an india-rubber cone.

We have dealt at some length with this perfected form of wash-down because it is now generally regarded for ordinary purposes as one of the more satisfactory.

An improvement on the ordinary wash-down is the "Bracket" closet by Messrs. Dent & Hellyer (fig. 106).

This closet is kept off the floor, so that the latter can be properly washed, and there is no chance of dirt and dust collecting. It has been used in many hospitals. The water surface to receive the motion is about 8 in. by 5 in., an improvement on some of the earlier forms, but it is not so large as Doulton's "Simplicitas," whose water area measures 10½ in. by 6¾ in.

We have now to deal with an important type of closet which is still preferred by some, and which if made in the best manner does possess some advantages even over the improved forms of the wash-down type. We refer to what

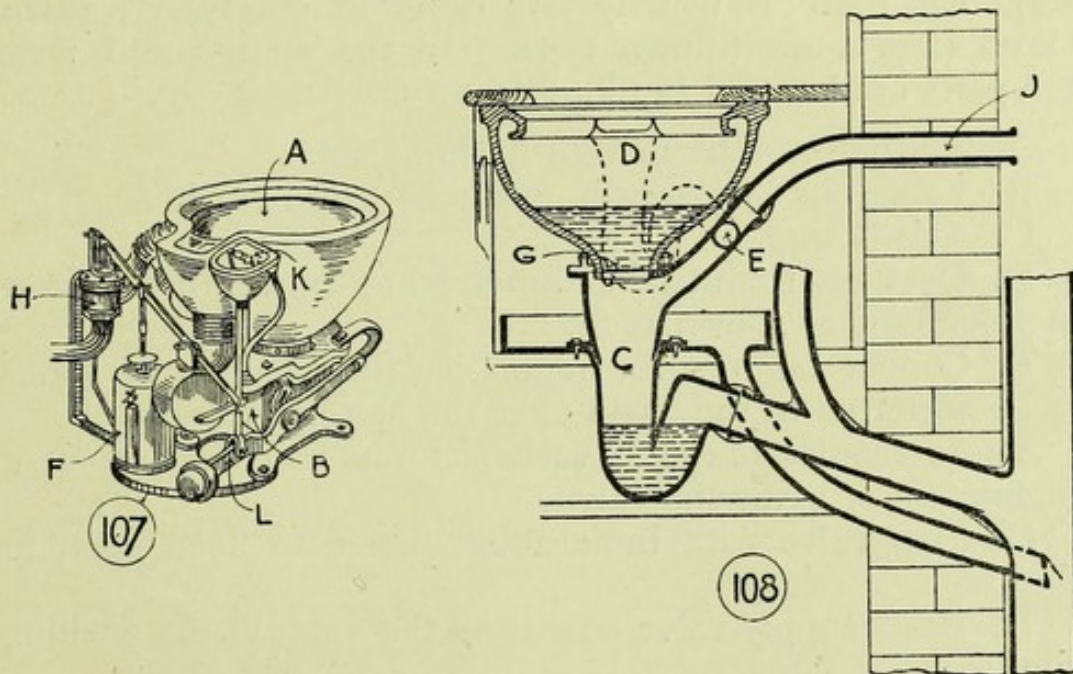

is known as the **valve closet**. By reference to the illustrations, figs. 107 and 108, an idea will be obtained of the appearance of a valve closet and of its more complicated appearance in comparison with the simpler forms we have been discussing.

The illustrations (a view and section) represent Mr. Hellyer's "Optimus" valve closet, and the various parts being lettered will be readily understood. The apparatus consists of three parts—the basin, the valve-box, and the lead anti-D trap placed underneath.

The advantages which a closet of this type possesses over others may be briefly stated. On reference to the section

it will be observed that a large water area (the contents equalling about a gallon) is available to catch the fæces, to thoroughly envelope them, and pass them through the pipes without adhering to the latter. The closet also possesses a double water seal and a closely-fitting valve, so that in the case of the closet remaining unused for some time, additional security is obtained; besides which the foul air in the soil pipe presses against the lower trap, saturates the water in it with foul gases, which are then given off, and escape by means of the ventilator to the valve-box. This is another advantage over a single trap. To these we may add that there is usually less noise in emptying a valve closet than a wash-down type. In the section and view the parts are lettered as follows:—

- A. Earthenware basin with flushing rim.
 - B. Valve box of cast-iron, enamelled white inside.
 - C. Anti-D trap.
 - D. Overflow from basin connected to the ventilation arm of valve box, as shown at E.
 - E. Copper bellows for regulatiug the quantity of water to be admitted to the basin after the handle is dropped.
- These regulators are of various forms and have either a pneumatic or hydraulic valve.
- G. Flap valve with indiarubber flange to keep water in the basin.
 - H. Brass supply valve admitting the water to the flushing rim.
 - J. 2-in. vent pipe to the valve box, simply carried to the outer air. This is also necessary for preventing the siphonage of the overflow to the basin.
 - K. The lever for opening and closing the basin valve.
 - L. Weight for shutting the supply valve.

The fittings to a good valve closet will, with very little attention, work satisfactorily, but in the majority of cases where no such attention can be given to them, it is, perhaps, advisable to substitute the best form of wash-down closet. Again, a wooden casing is usually considered necessary to hide the mechanism, and this usually succeeds in hiding a good deal of dirt and filth at the same time.

The supply of water is not a regular one, but dependent on the person using the plug, whereas in the ordinary wash-down one pull of the handle empties the contents of the water-waste preventer into the basin. In valve closets a water-waste preventer is not used, but the flushing water should be derived from a special cistern, properly disconnected from the cistern which supplies the water service of the house.

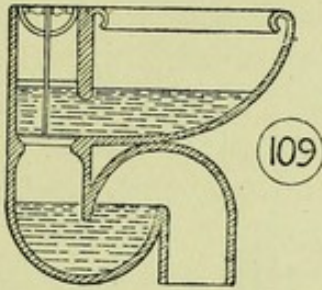

An illustration of a "plug" valve closet is given in fig. 109, which will explain its construction, in which it will be observed that there is no valve chamber. It is, however, seldom used and can scarcely be recommended.

Siphonic Closets. — These are based on principles that have found favour in recent years, and which have been used with success, although it is doubtful whether they have been sufficiently long before the profession to constitute a lasting trial. The one shown in the illustration, by Messrs. Shank (fig. 110), gives one a fair idea of the principles on which it is designed. The points to be noticed are its deep seal of 8 in., the large water surface of $13\frac{1}{2}$ in. by $11\frac{1}{4}$ in., its powerful suction properties, and there being no joint on the drain side of the trap. It is said only to require a two-gallon flush.

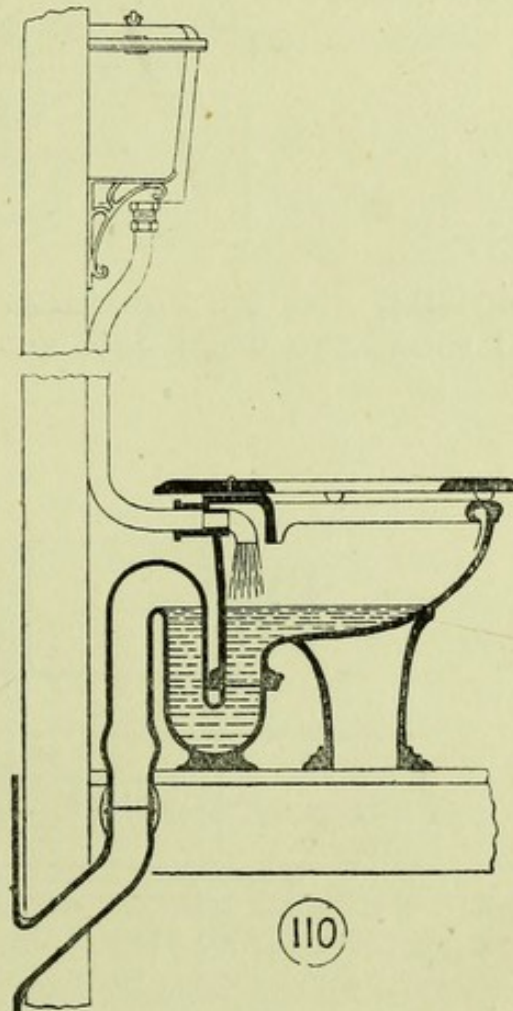

Messrs. Jennings & Morley's siphonic discharge closet,

shown in fig. 111, has a surface area of 12 in. by 10 in., and the trap has a 3-in. seal. The illustration shows the closet fixed over a 4-in. lead trap. The joints M and N must be

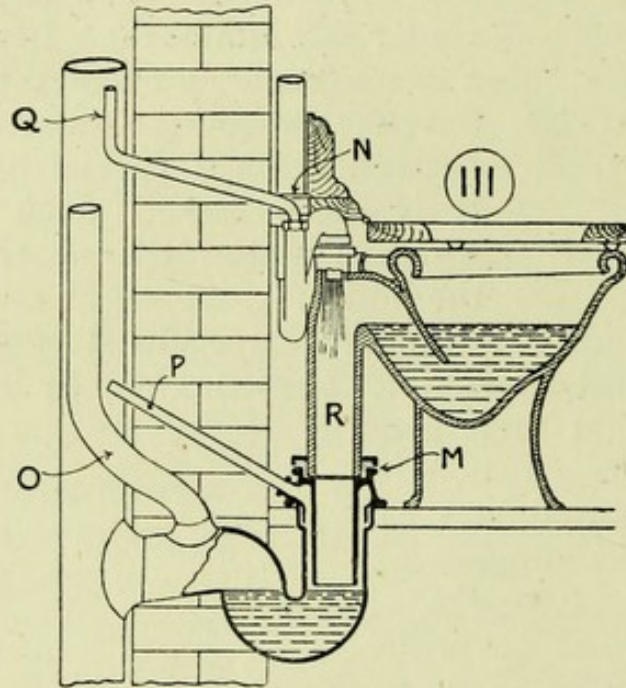

air-tight, and are formed as shown in figs. 112 and 113. O shows the usual 2-in. anti-siphonage pipe. P is a puff

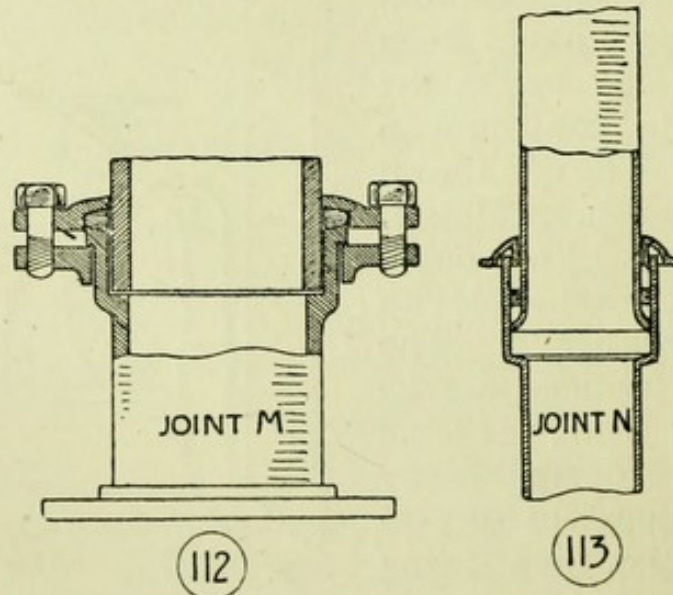

pipe, taken through the wall and left with an open end. The in-coming water expels the air through this pipe and starts the siphonic action. Pipe Q admits air to the

siphonic leg R, and prevents the siphonage of the basin when slops are emptied into it. It should be noted that the service-pipe from the cistern has two connexions to the closet, one leading into the basin, and the other into the top of the long leg of the siphon-pipe R.

The siphonic closets have been used largely in America, and they seem to be gaining favour in England at the present time for public purposes.

Trough Closets or Latrines are, on account of ease and economy in working, often used in factories, schools, and barracks. They merely consist of a glazed stoneware channel, raised at one end so as to leave a water area of sufficient size and depth to prevent the soil becoming objectionable. The illustration (fig. 117) shows one of Messrs. Doulton's manufacture. It is made in salt glazed

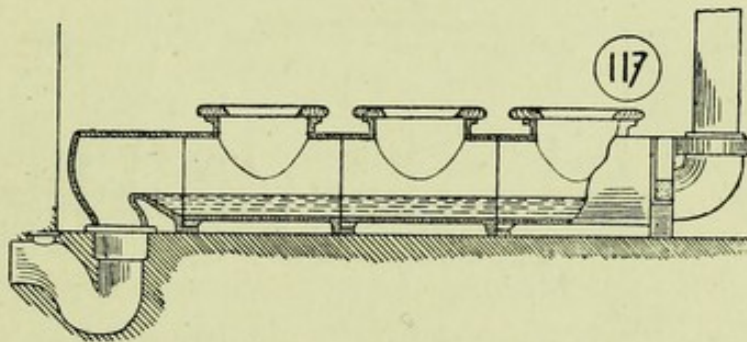

stoneware, and the partition walls, if used, would come over the joints of the trap. The closet is flushed out by means of an automatic flushing tank, which should hold enough water to thoroughly displace the water in the trough and flush out the contents. An S or P trap is placed at the end of the range and should be ventilated at its outgo,

It will be seen that there are no risers to the seats, so that the trough can be thoroughly cleaned internally and externally.

Automatic Flushing Closets are now much used in public buildings, &c. By means of a weight the seat is raised on the user rising; this has the effect of starting the siphon in the water-waste preventer, and also renders the closet ready to be used as a urinal. The automatic flushing may also be effected by means of the shutting of the door, &c.

3. **Flushing Cisterns and Water Waste Preventers.**—These are now used to all ordinary wash-down closets and urinals which are fitted with S or P traps. They are of several varieties, and some illustrations are given. They usually, by the regulations of the water companies, contain only two gallons, but wherever possible three gallons should be provided. The best are those which work on the siphonic principle, so that the chain attached to the plug only requires pulling, and even if let go immediately the contents of the cistern are at once discharged. It is a great advantage over the ordinary valve, which required the chain to be held until the contents of the cistern were emptied (see fig. 114).

Fig. 115 shows a flushing cistern of the ordinary plug siphon type. By raising the plug by the chain, the water

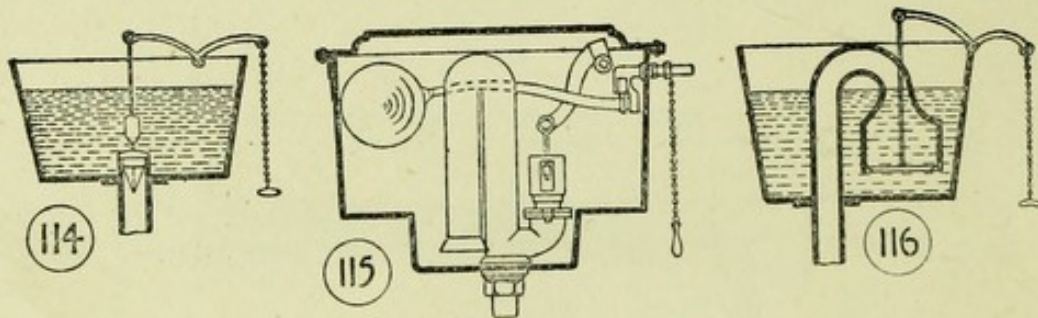

rushes through the opening, and starts the siphon by raising the water over the top of the siphon bend; the siphonage, once being started, continues until all the water is drawn through. The cistern is then refilled from the supply cistern, until it reaches just below the top of the bend, when it is stopped by the ball valve. It is then ready for use again. It is not always a waste-preventer, as, if the valve leaks, the water may waste down the flush pipe into the pan.

Another form is that shown in fig 116, which is an ordinary dip. In this case the chain, being pulled, lifts the disc in the enlarged mouth, which forces the water over the bend, and creates a vacuum which starts the siphonage, and empties the cistern, which again refills to the proper height. This is a waste-preventer, because the water would

come out at the overflow before discharging down the siphon.

4. **Soil Pipes and their Ventilation.**—Lead soil pipes should be made of strong hydraulic-drawn lead; they should be at least of 8-lbs. thickness (*i.e.* weighing 8 lbs. to the square foot). Thus, a 4-in. pipe should weigh rather more than 8 lbs. to each foot of its length. Soil pipes should be as straight as possible from the bottom to the top; they should be placed on an external wall, and not in chases in the wall, because they are difficult to repair in that position.

Although 8-lb. lead is required for a soil pipe, the portion above the topmost water-closet or sets of water-closets, and which is used merely for a ventilating pipe, need not be made out of stouter material than 6-lb. lead. Some authorities advise as little as 3-lb. lead, but even 4-lb. lead is nearly too thin to retain its shape. When inside a building the London County Council requires the soil pipe to be continued upwards of the same substance, and this should always be done in the best work. Joints in lead pipes should be “wiped” joints, which are made by the plumber in the following way (see fig.

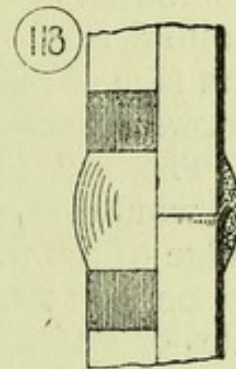

118):—A socket is formed on the upper end of the lower of the two pipes to be joined, by means of the “turning pin,” the spigot of the upper pipe is rasped off to a feather edge, so as to fit into the lower pipe. The pipe ends, for a distance of about 4 in. to 9 in., are then covered with a mixture of size, lampblack, and powdered chalk, called “soil” or “smudge,” which prevents the solder *tinning* (adhering) to the pipe beyond that part that the joint is to occupy. The extreme ends of the pipes are then cleaned of the soil by scraping. Molten solder is then poured around the joint and wiped into shape by means of a cloth, the “soil” preventing the solder adhering beyond the point desired. Soil pipes are sold in such lengths that a soldered joint is generally required about every 10 feet in height.

The soil pipes are secured to the walls by "tacks" of 7 lbs. or 8 lbs. lead; often placed about 5 ft. apart centre to centre, and usually 10 in. deep. In best class of work three tacks are used to each 10-ft. length of pipe. They are, therefore, put on with about 3 ft. 4 in. centres. These tacks may be made in pairs or singly, and are merely soldered to the back of the soil pipe

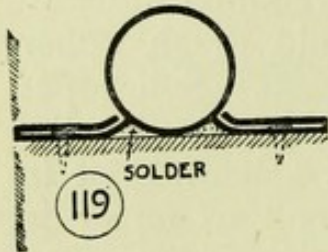

and secured to the wall by two or three wall hooks to each tack. Illustrations are given in figs. 119 and 120. In better class work a feature is made of the jointing, and what are known as "astragal" joints with tacks are employed. This joint consists of a combination of a wiped solder joint and tacks, hollow lead mouldings being soldered on to the face of pipe for effect. See fig. 121, which shows a section of this joint.

The soil pipe should be carried well above all windows, or, better still, carried up to the ridge of the roof; but there does not appear to be any reason why it should rest on the tiles or slates of the roof, where it is an eyesore to every passer-by. It may be taken up inside the rafters, being enclosed in a wooden

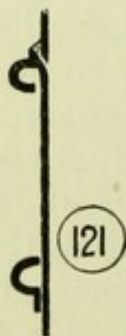

or other casing to prevent it being damaged. The unreasoning extent to which some Local Sanitary Authorities through their surveyors will go in demanding the execution of their own private fads in this direction is remarkable. No harm can come of hiding the ugly soil pipe above the eaves. It is bad enough, but necessary, that our walls should have to carry our soil pipes, but to see them sprawling in all directions over our roofs without any reason is simply to cause an unnecessary eyesore.

The junction of the soil pipe with the water-closet trap

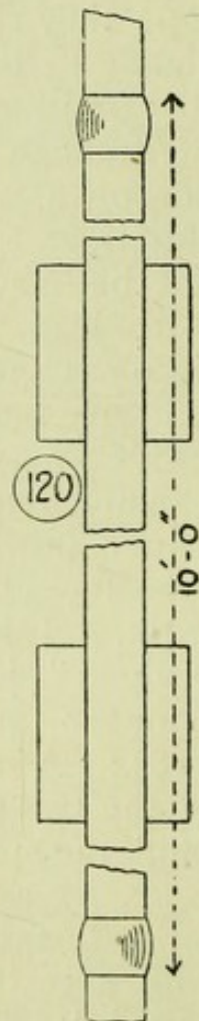

has been already dealt with, but its junction with the earthenware drain-pipe has not yet been referred to. It is one of the most important joints in the whole system of drainage. It is effected by means of a brass ferrule joint similar to the connection of the water-closet. This already has been explained and illustrated. The lead is protected by the brass collar connected to it by solder, and the space between the brass and the earthenware flange is filled in with neat cement. It will be readily understood that sewage is liable to gather at this point, and this has led to a patent being taken out for the special shaped pipe by the Loco Drainage Company, of which an illustration is given in fig. 122. In this the sewage is deflected down the earthenware drain more easily than in the ordinary bend. This pipe must, of course, have a proper foundation of concrete, as explained under "Drainage."

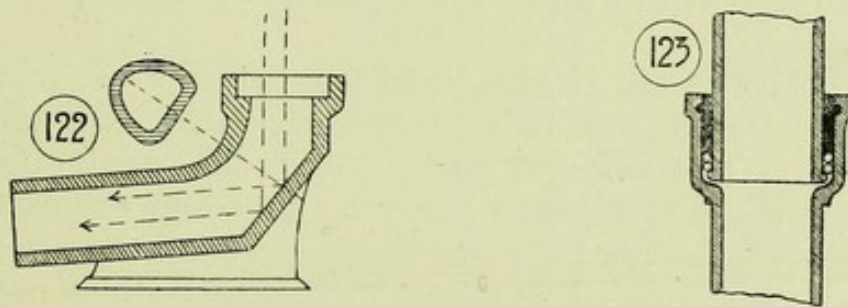

Above we have merely dealt with lead soil pipes, because they are generally considered the best. A lead soil pipe is, as a rule, smoother, and therefore cleaner than an iron one. It can be bent to any position, the joints of wiped solder are perfect, and the lead pipe will "give" a little in case of any settlements. Urine, being corrosive, will act on iron more than lead. Lead pipes do not require painting, whereas iron pipes do. If iron soil pipes are used, they should be galvanised to prevent rust, and treated with some process, like the Bower-Barff, or with Dr. Angus Smith's solution.

They should be of special thickness, and the jointing should be of the caulked lead type, made in the following way, as shown in fig. 123. Two or three rings of spun yarn are placed in the socket to prevent the molten lead from

getting into the pipe, then the molten lead is run in and well caulked into the joint. The groove in the socket will check any tendency of the lead to come out.

The comparative advantages of iron and lead soil pipes have been frequently discussed. In American cities lead soil pipes are prohibited, as iron is considered a better material for the purpose. It may be so in the States because the climatic conditions necessitate that the soil pipes be placed inside the building, in which position lead is more likely to be damaged. In several instances we have come across cases in which nails have been driven through floor-boards and casings and have thus perforated lead soil pipes. In one case the soil pipe ran through a bedroom, and holes had been made in it, evidently by a carpenter's chisel, while putting up the casing.

In consequence of this liability to damage many consider it advisable that soil pipes when placed internally should be of iron.

5. Baths and their Wastes.—Baths are made of various materials, such as enamelled iron, copper, and porcelain. The wooden enclosure, which was considered so necessary a few years back, is now almost discarded, and rightly so. We have already insisted on the advantage of doing away with all "casings," and the subject need not be further pursued. "Out of sight out of mind" is a saying which every householder should remember and act up to. The bath should be washed periodically both outside and inside in order to keep it clean and wholesome.

The floor may be laid with tiles on concrete, or with mosaic, and should be sloped to an outlet pipe and provided with a skirting all round.

A bath-room should, if possible, have a fireplace for ventilation. A section is given of a bath on a first floor, which shows the usual treatment (fig. 124). In this case the bath is of porcelain, and stands on four legs without any casing. It is fitted with 1½ in. lead waste (it never should be less), having 1½ in. anti-D trap (ventilated to prevent siphonage), discharging into a 2-in. main waste which is carried up and ventilated.

The overflow is a 2-in. pipe, and is carried into the lead

safe. When the floor is not impervious, there should be placed under the bath a lead safe, bossed out of 4-lb. lead, with $2\frac{1}{2}$ in. left at the edges and the slopes to throw the water towards the outlet, and having a 2-in. overflow direct to the open air with brass flap at the end.

The waste from a bath is often delivered over a rain-water head, and this system is preferred by many; but if this happens to be near a window, the effluvia from the dirty water is often offensive.

In confined situations especially, as, for instance, in the light and air wells of blocks of flats, these rain-water heads give off very objectionable smells. It is perhaps, therefore, better to connect branch wastes from baths and basins to

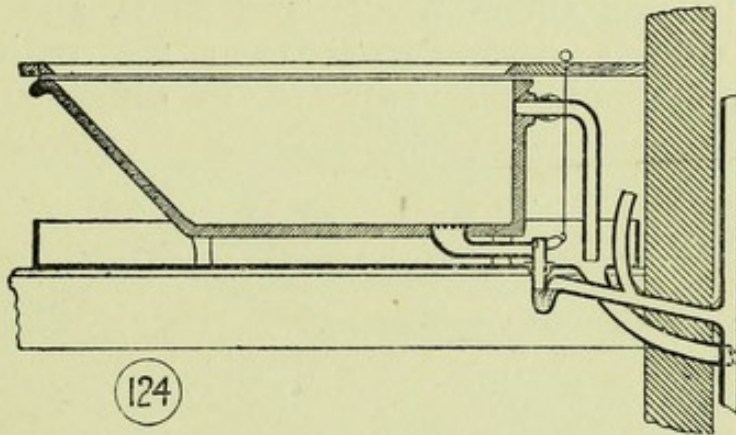

main waste by means of Y-junctions rather than discharge them into successive hopper heads.

According to the Metropolis Water Act the supply pipes must come into the bath above the water line, but this is too high for the hot-water service, and causes the room to be filled with steam. It is therefore better that the hot water should be brought in at the bottom of the bath.

Bath fittings are too numerous for us to enter upon, except to mention that valves are preferable to screw-down cocks. In order that the bath may be quickly filled supply pipes of not less than 1 in. diameter should be used for upstairs baths, and not less than $\frac{3}{4}$ in. for downstairs baths.

Of course the size depends really on the height of cistern and hot-water tanks, and consequent head of water; but those mentioned are generally ample.

6. **Lavatories and their Wastes.**—Lavatories are of several types, and are usually made in glazed earthenware, but may be roughly divided into

- a. *Ordinary Basin with Plug.*
- b. *Tip-up Lavatories.*

The latter are much used and preferred by many, as they have the advantage of emptying the basin quicker. The receiver, in which the dirty water is thrown, should be cleaned periodically, as the smell arising from decomposing soapsuds is most unpleasant and unhealthy.

An illustration is given of an improved type of lavatory, figs. 125 and 126, showing the treatment of the waste, which should discharge over an open rainwater head or into a gully trap (if on the ground floor), and which is therefore entirely disconnected from the drain. The anti-D trap should be ventilated in order to prevent

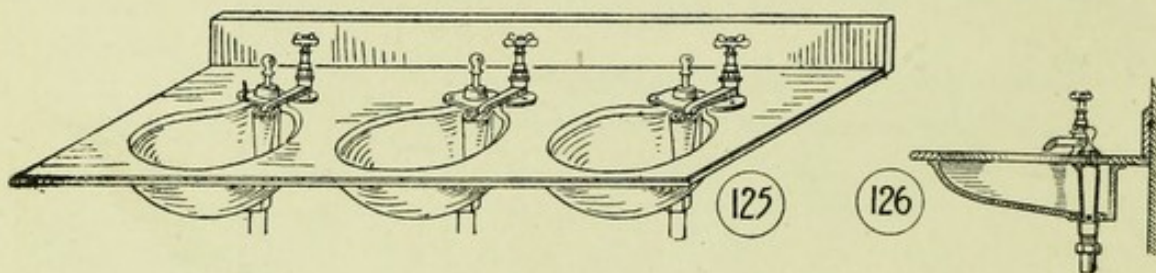

siphonage. If several lavatories occur in stories one above the other, the wastes from each should be taken into a main waste pipe which is carried up and ventilated and which discharges into an open gully at the bottom.

In this case, the traps to each lavatory are ventilated into a main ventilating pipe, which is carried up and connected with the main waste 6 ft. above the highest fitting.

The waste pipe from a single lavatory should be at least $1\frac{1}{4}$ in., or even $1\frac{1}{2}$ in., in diameter. The overflow is always a cause of annoyance in consequence of the difficulty of keeping it clean. The illustration, fig. 127, shows one of Mr. Hellyer's lavatories in which the back part of the basin is recessed to receive a trumpet plug of gun metal, which also forms the overflow, the water falling over the top when it reaches that level. This is readily removed for cleansing purposes.

Care must be taken in bath and lavatory fittings that the plug and washer give a clear way of $1\frac{1}{4}$ in. for the outlet, as shown in fig. 128.

In a range of lavatory fittings, as in a school or club, each fitting should be trapped by means of an anti-D trap,

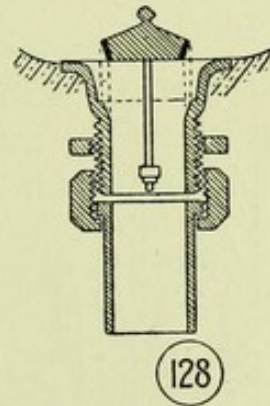
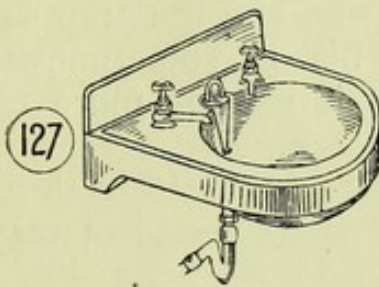

which should be ventilated, as shown in fig. 129, to prevent siphonage.

7. **Urinals** are not as a rule necessary in a private house. The wash-down closet with hinged seat should be placed in the ground floor water-closet, and this answers the purpose of a urinal.

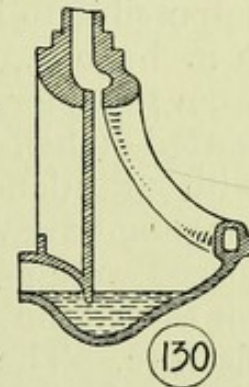
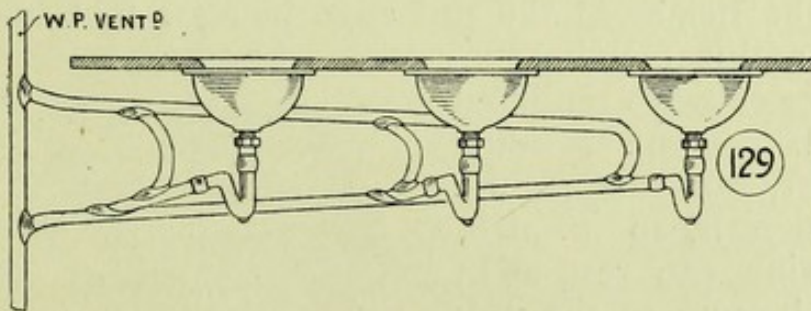

One great point in sanitation is not to increase the number of sanitary fittings more than is necessary. If a water-closet will answer the purpose of a urinal, as it may do perfectly well, let it be used for such a purpose. Urinals where used should be trapped like other sanitary fittings, fig. 130, and the waste-pipe ventilated exactly like a soil

pipe. Fig. 131 shows Mr. Hellyer's "Wide-fronted" basin *in situ*, with the traps ventilated by an anti-siphonage pipe, which should be carried up above the topmost fitting and then connected to the ventilated waste pipe.

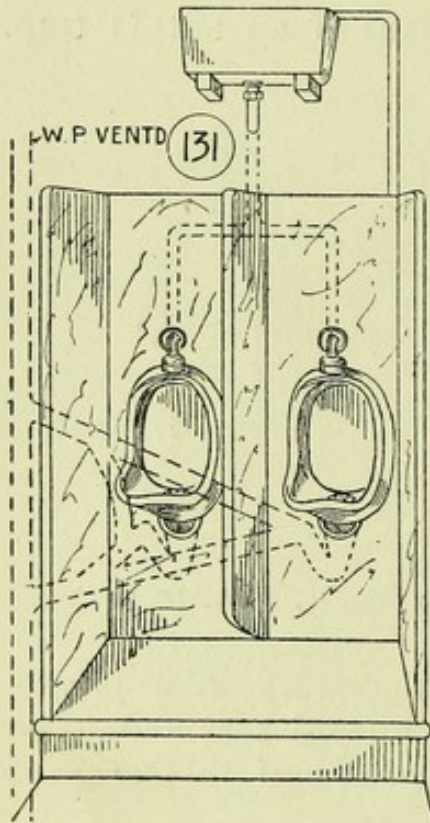

Urinals sometimes discharge into an open glazed half-pipe. This latter should be trapped at its lower end and the trap ventilated. This is sometimes preferred, as it can be more easily cleaned down.

8. **Sinks and their Waste.** This part of our subject may be divided into three parts—

- (a) *Scullery Sinks.*
- (b) *Housemaids' Sinks.*
- (c) *Butlers' Sinks.*

(a) **Scullery Sinks** are best when made of glazed stoneware, so as to be easily cleaned. The old-fashioned York stone sink is bad; it absorbs the grease, and is impossible to keep clean. A scullery sink is generally about 3 ft. by 2 ft., the height of the top edge being 2 ft. 6 in. from the floor, and it may be supported on half-brick walls rendered with Portland cement. Some makers, however, now make white glazed ware pedestals, 20 in. high, on which the sink can rest, as in fig. 132. The bottom of the sink should have a good fall towards the outlet, which is placed in the corner of the side adjacent to the outer wall, and should be provided with a $3\frac{1}{2}$ -in. bell-mouthed "cobweb" grating to arrest the solids. The waste should be at least of 2 in. internal diameter, and should be trapped with an anti-D trap, fitted

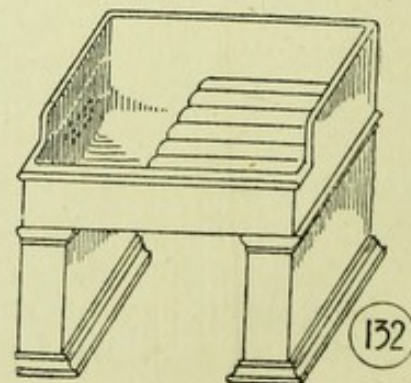

with inspection screw in case of blockage, and should discharge into an open pipe connected at its lower end with a trapped gully so as to be disconnected from drain.

One difficulty to be contended with is that the grease, which naturally is shot down the scullery sink, if it is allowed to enter the drains, is liable to clog them, as explained in the chapter on house drainage.

(b) **Housemaids' Sinks.**—The housemaid's sink is usually fitted up in connection with a slop sink for the emptying of dirty water. It is true that the slops from the bedrooms can be thrown down the water-closet in an ordinary house, and bearing in mind the value of not multiplying sanitary fittings more than possible in small houses, this can be done with advantage provided the closet basin

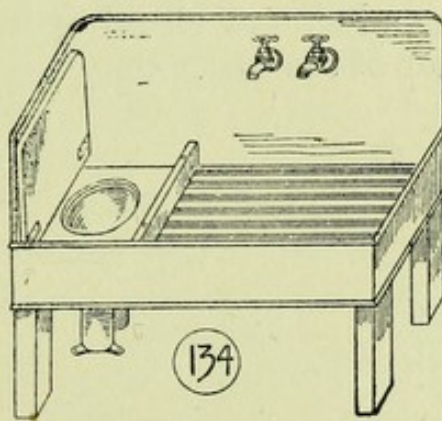
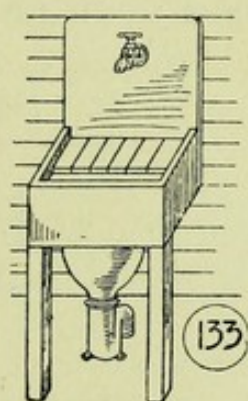

is provided with a lift-up seat, or with a "slop top." Fig. 133 shows an ordinary slop sink in slate with an earthenware pan and trap with tap in back slab. Fig. 134 shows a Doulton's combined wash-up and slop sink. It has an earthenware basin and trap and supply valve for hot and cold water. The wash-up sink is provided with a wooden grating to prevent crockery being broken against the hard slate bottom.

(c) **Butlers' Sinks** are as a rule lined with lead, the sides being of 7-lb. lead, and if they are to have much hard work the bottoms being of 10-lb. lead.

They can be obtained of glazed earthenware, but it is found that in consequence of the unyielding nature of this material, breakages are more frequent than if of wood lined

with lead as described. Some are now made of copper lined with tin. A butler's sink is fitted with hot and cold water with bib taps, and should be about 15 in. deep. This

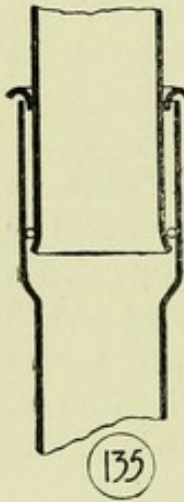

depth is required so that bottles or decanters may be held underneath the taps. The waste pipes should be fitted with anti-D traps to which a screw inspection cap is attached.

Where a lead waste pipe has a large amount of hot water continually passing through it, the joints are sometimes constructed on the principle shown in fig. 135. This is known as a "telescope" joint, and allows for expansion and contraction of the pipe. This is obtained by means of a solid rubber ring passing round the inside of the

upper pipe, and allowing it to move up and down in the socket of the lower one.

CHAPTER IX.

THE COLLECTION AND DISPOSAL OF REFUSE AND SEWAGE.

THE collection and disposal of refuse as distinct from excreta :—

1. *Collection.*

2. *Disposal.*

1. **The Collection of Refuse** from buildings has undergone a considerable change for the better within recent years, and the establishment of daily removal in many districts is a distinct advance for many sanitary reasons. By this method the refuse collected during the day is placed in galvanised iron buckets, which are emptied into the removal van, and the buckets are disinfected and returned to the occupier. The old-fashioned method of a brick dustbin, which is emptied once every week or fortnight, is not to be encouraged, but in some instances it is unavoidable. In these cases the floor of the dustbin should never be below the surface of the ground, and both the floor and sides should be of impervious material. It should also be protected from the effects of sun and rain, and should be removed as far as possible from any dwelling, and more particularly from any source of water supply. It is important that as far as practicable everything should be burnt before being placed in the dustbin; this refers more especially to all garbage and vegetable matter. Specially arranged kitcheners are now manufactured, which fulfil this purpose by means of a firebox under the grate.

2. **The Disposal of Refuse** has of late occupied an important place in the deliberations of Local Authorities, and dust and refuse destructors have increased to a larger extent within the last few years. In the City of London the refuse is picked over and a certain amount of money is made by selling the proceeds derived therefrom, such as string, bones, and cinders, &c. The remainder is then

cremated. This system, however, is not so healthy as destroying the whole of the refuse by burning. Some Local Authorities sell some of the refuse to brickmakers, who use it in their kilns for firing. This, however, causes an almost intolerable smell to the adjoining owners. Some authorities endeavour to utilise the heat from the ignition of the refuse for the purpose of producing electric current. The low heating value, however, renders necessary the admixture of coal; and in most cases it is probably more economical to use coal only for the purpose of producing electricity. The dust destructor should, moreover, be as isolated as possible, and in the future it will probably be found more advantageous in many respects to burn the refuse separately and not attempt to use the heat derived therefrom for any such purpose as producing electricity.

THE COLLECTION AND DISPOSAL OF SEWAGE.

1. *Collection.*

2. *Disposal.*

3. *Treatment of Sewage.*

1. **THE Collection of Sewage** is carried out either by (a) *the conservancy* or (b) *the water-carried system*.

(a) **The Conservancy System** consists in the use of privies and earth closets with fixed and movable receptacles. The earliest form of privy was a seat placed over the "midden" (a shallow pit). The latter was usually unlined, but sometimes a rough brick or stone interior was used. This method, of course, is very unsanitary, and is not now much in use. The later kinds may be classed according to whether they have fixed or movable receptacles, but in either case the seats should be easily removable. The fixed receptacles have many disadvantages, but where they are used care should be taken that they are perfectly watertight, and a smooth impervious surface should be provided. No angles to collect the excreta should be permitted, and the outlet should be easy of access. Fig. 136 shows a good form of this class of privy. Movable receptacles generally imply what is known as the "pail" system. These are provided by the Local Authority, and when removed by them in air-tight vans a clean and disinfected one is left in

their place. A well-known authority has referred to this system as a "filthy, stinking abomination," and, though this system is still in vogue in some towns in the North of England, this description is not too emphatic. There are various forms of ashpit privies in which the house refuse is used as a deodorant, but they are all to be condemned on sanitary grounds.

Where the conservancy system has perforce to be used the **earth closet** is, undoubtedly, the best method. Dry earth is used as a deodorant whether fixed or removable

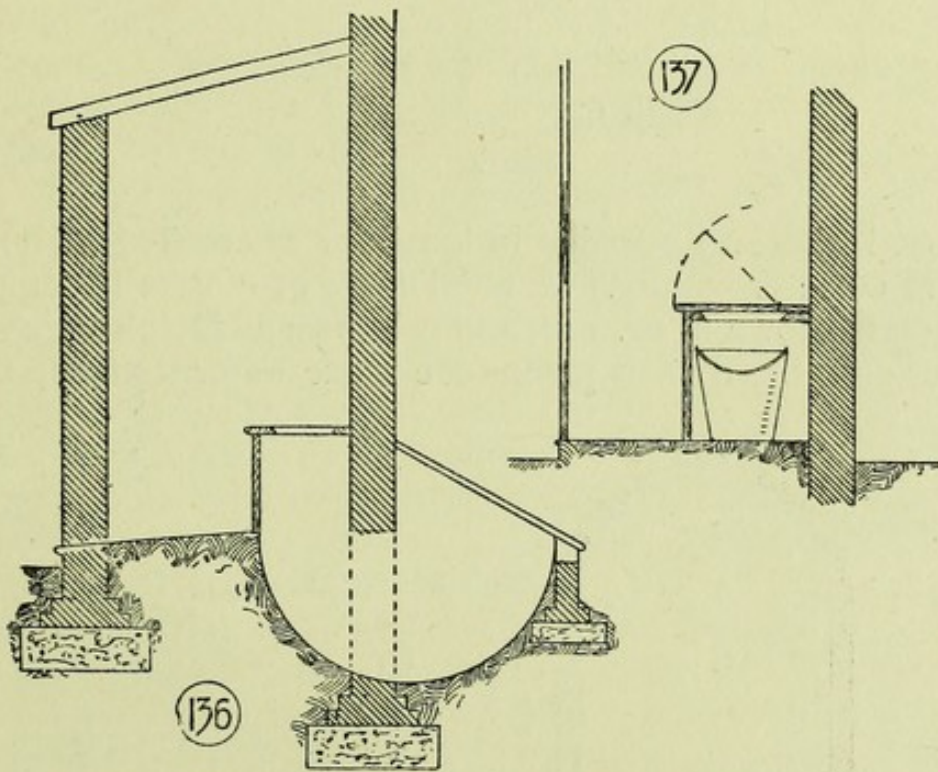

receptacles are used. This earth should be of as loamy a nature as possible, and it has the effect of turning the excreta into a kind of vegetable mould.

Fig. 137 shows a good form of earth closet with pail. The latter should be emptied early every morning and properly cleaned and disinfected. Fig. 138 illustrates Morrell's system of sifting ashes for use with pail closets, and this is to be recommended.

Where **cesspools** are used they should be made of brick or stonework in cement and should be rendered inside and

out with an impervious material. They should be domed over at the top, as shown in fig. 139, and should conform with the regulations of the model by-laws explained in Chapter II.

(b) The **Water-carried System** is the one that should

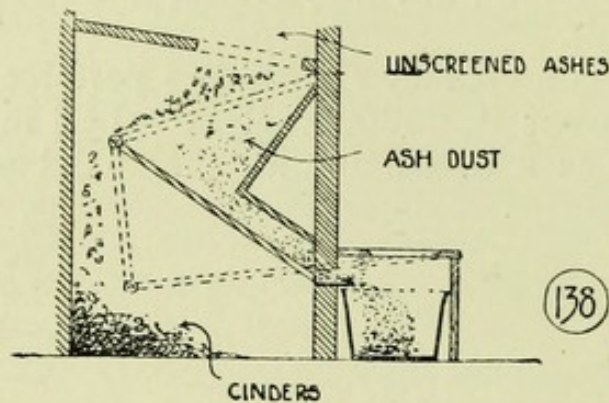

be used wherever possible in localities where several houses are in close proximity. A good form of closets for country houses is shown in fig. 140, and is known as **Duckett's** slop-water closet. By this means the waste water from the sinks

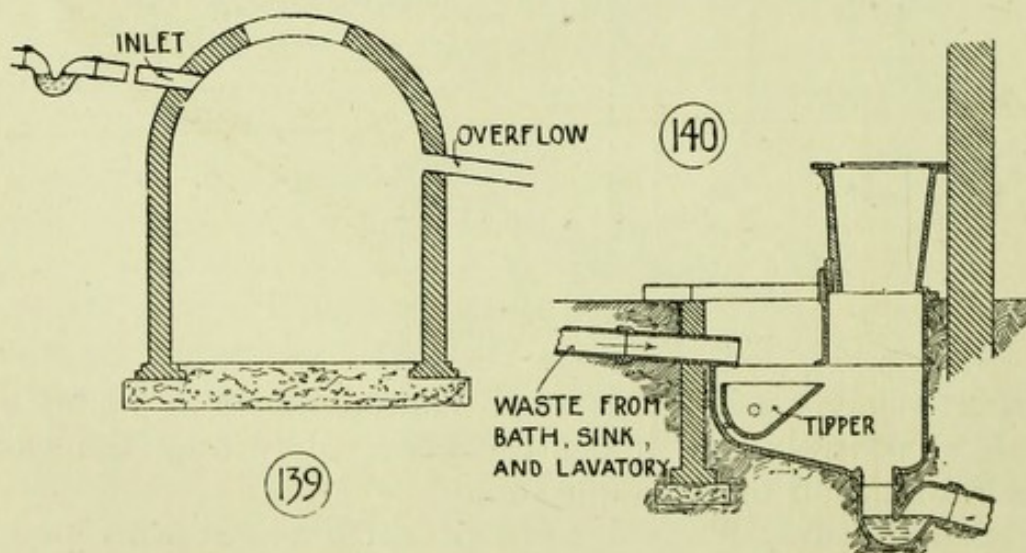

and baths is used to automatically flush the drain. This form is very useful where the water supply is not found to be plentiful.

In **Main Drainage** it is generally considered to be advisable to carry away the bulk of the rainfall in separate

sewers or storm overflows. Professor Henry Robinson estimates that 6 cubic feet of sewage per head of the population per day may be taken as a fair average, and this includes the rainfall from roofs and yards, &c., but not that from the streets, &c. This amount, of course varies very considerably in different localities, and where the storm water is conveyed in the same sewers an addition should be made. One inch of rainfall an hour produces $14\frac{1}{2}$ millions of gallons per square mile ; but, of course, a very large percentage of this is absorbed by the land, and is diffused by evaporation.

The **velocity** in sewers should be between 2 ft. and 3 ft. per second. Sewers should be **ventilated** at least every 100 yards of their length, and sufficient outlets should be provided at points as high as possible above the sewer. In some cases lamp-posts have been used for this purpose, and the upcast is assisted by the heat generated by the lighting medium ; and this is a good method if sufficiently distant from dwellings. Factory shafts have also been utilised for this purpose.

The **egg-shaped** form of sewer, as shown in fig. 141, is the best form, as a higher velocity is obtained with a dry-weather flow, owing to the smaller sectional area of the lower part of the sewer.

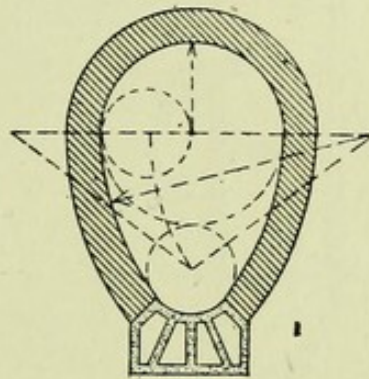

(141)

2. THE **Disposal of Sewage** is a matter of vital interest to every community, and of recent years much ingenuity and thought has been monopolised by this subject. We may consider it under the following heads :—

- (a) *Irrigation.*
- (b) *Discharge into the Sea.*
- (c) *Discharge into Rivers.*

(a) **Irrigation.**—For country houses a pair of small

settling tanks are sometimes used (see fig. 142). These tanks are used alternately, so that one may be cleaned out while the other is in operation. The sewage in passing through the tank deposits a certain amount of the solid particles, and a screen B B further assists to arrest them. A cake of alumino-ferric is also sometimes used for the purpose of precipitating the solid particles to the bottom of the tank. The deposit in the tank not in use should be removed and dug into the ground. From the outlet the effluent is conveyed along an open glazed pipe to a small irrigation field, and branches are taken over the ground in different directions. The effluent must be discharged intermittently over the same ground, as constant filtration

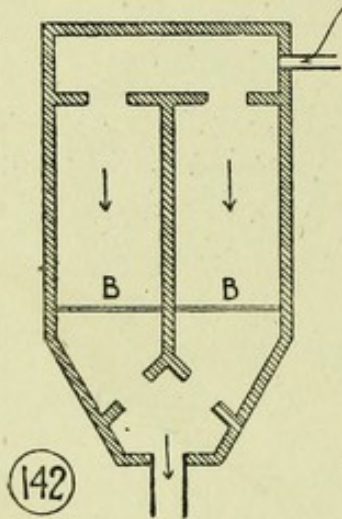

is not successful. Sub-surface irrigation is also sometimes resorted to. The idea of the disposal of the sewage of towns and villages by irrigation led to some very erroneous figures and statements being put before the public some years ago. This was mostly due to the supposition that the full chemical value of sewage could be utilised by the ground on which it was placed. This has proved to be a great fallacy, and is to a great extent due to the fact that the sewage must be disposed of every day, while

the land only requires it for manurial purposes at certain times. Claylands are entirely unsuited for sewage irrigation, but they have in some cases been rendered more efficient by the ploughing in of ashes and other materials. Sandy soils are usually adaptable for this form of irrigation. Great care must be taken that the subsoil drains are put at the right levels to insure that the effluent passing off the sewage farms should not be foul. The ground is usually prepared on the ridge and furrow system, and channels are formed in the ridges so that the sewage may flow over them into the furrow in a uniform stream. Italian rye grass is considered one of the best crops to raise on a sewage farm, though many other crops are produced with success in various localities.

The sewage from the City of Berlin, which has a population of over one million and a-half, is treated on sewage farms which have an area of nearly 20,000 acres. Over thirty millions of gallons are treated daily, but this includes all storm water. Many towns in England dispose of their sewage on this principle, notably Norwich and Reading.

(b) **Discharge into the Sea.**—The Local Government Board permit of sewage being ejected into the sea below low water level. But this should not be allowed unless there is a well-defined current that will carry it away from the shore without any chance of its being washed back again. It is also most important that other communities should not receive these discharges, and no system should be inaugurated that is likely to cause the sewage to be a nuisance to any other place on the coast. The specific gravity of sewage being less than sea water, and the fact that it is discharged at a higher temperature than the sea, causes it to rise to the surface directly after it is discharged from the outfall sewer, and unless it is carried away to sea at once, it is liable to be a great nuisance and to foul the sea shore.

(c) **Discharge into Rivers.**—The Public Health Act of 1875 and the Rivers Pollution Act of 1876 were drafted for the purpose of preventing the fouling of rivers by the discharge of crude sewage and trade effluents. And the Local Government Act of 1888, which empowers the County Councils to enforce the Act of 1876, and gives powers to the Local Government Board to form and invest committees with powers under that Act, has done something to prevent our rivers from becoming merely open sewers. Manufacturers are only too prone to discharge their unpurified trade liquids into the nearest stream, and they should in all cases be compelled to treat their waste water before it leaves their works.

The actual effect of impure discharges into a stream on piscatorial life is difficult to define. Some eminent authorities are of the opinion that the fish are not destroyed by poisoning in the ordinary sense of the word, but by suffocation, the latter being brought about by the inability of the fish to contend with the sewage in their joint endeavour to absorb oxygen from the water.

Dr. Percy Frankland has shown the purifying action of running streams upon sewage by taking samples of water from the River Dee, into which sewage was discharged at various points. By the increase and decrease in the number of microbes he demonstrated that bacteriological purity was continually being restored. Dr. Frankland has also proved the value of storing water, in that pathogenic germs are reduced after subsidence of the suspended particles has taken place. Thus it will be seen that the river water itself may become fairly pure, while the bed of the river receives the filthy subsidence. Professor Henry Robinson maintains that the River Thames is becoming year by year less foul since the character of the effluent has improved, so that the day may come when fish, that have for long been absent from this historic river, may be seen again as in the long past centuries.

3. **Treatment of Sewage.**—Where the nature or cost of the land does not permit of filtration, some chemical system is usually employed for the purpose of precipitating the sewage to be dealt with.

Lime processes, at the present time, are mostly employed for this purpose. At the Barking and Crossness outfalls of the Metropolis one quarter of a ton of lime in solution, containing one grain per gallon of protosulphate of iron, is added to one million gallons of sewage. Permanganate of potassium is also added during the hot weather. The cost alone of treating the London sewage with chemicals is estimated at about 30s. per million gallons.

Copperas, ferric and alumina sulphate are also used in many systems for the treatment of sewage. The effluent resulting after the precipitation is sometimes discharged direct into a river or stream, and sometimes it is filtered through sand, coke, or other filters before being allowed to escape.

The **Native Guano or A.B.C.** process consists in treating the sewage with alum, blood, clay, and charcoal, mixed in about the relative proportions of 1, 2, 3, and 3 respectively. This system is now in operation at Kingston-on-Thames, and the effluent is considered so pure that it is permitted to be turned into the Thames without any

filtration through land. The precipitated sludge is compressed into cakes and afterwards pulverised, and is said to be worth some 30s. per ton. It may be open to question whether the agriculturist is of this opinion.

The **Amines** process consists in adding lime and herring brine, the latter acting as an antiseptic and preventing the decomposition of the effluent.

The **Hermite** process consists in the electrolysis of sea water, or a solution of sodium and magnesium chlorides. The resulting antiseptic is then run into the sewers near their commencement, and it is claimed that the sewage thus treated may be safely discharged from the outfall into the sea or any adjacent stream. This system is now in operation at Ipswich, and the River Orwell takes the treated sewage.

By the **International Company's** system the solids in the sewage are precipitated by ferrozone, which latter contains ferrous iron, magnesia, magnetic oxide of iron, and alum. The effluent is then passed through an aërated filter of sand, gravel, and polarite.

The **Scott-Moncrieff** system embodies the ingenious principle of harnessing the microbe and compelling it to liquefy the organic substance in the sewage, so that no sludge is produced as in the other methods referred to. The fresh sewage is brought into the bottom of a tank containing flints, and flows upwards through the latter, and by the agency of its own liquefying organisms the resultant liquid at the top of the tank is dark-coloured and offensive, and contains the original organic matter in the sewage in a condition susceptible to further changes. This effluent is then run through half-channel pipes filled with coke, with the object of obtaining nitrites and nitrates from the inorganic nitrogen. The success of these cultivation filters depends on the establishment of their nitrifying action, and the absence of oxygen is apparently fatal thereto ; so that refuse from factories would probably stifle the filter altogether. Moreover, the mineral matter obtained in town sewage would apparently affect the liquefying properties of the organisms.

The **Septic Tank** system was designed for the purpose of increasing the micro-organisms. A large light and air-tight tank is constructed, and the sewage is delivered into

it below the waterline, the outlet being also submerged. The solids in the sewage, on entering the tank, sink to the bottom or rise to the surface, according to their specific gravity. The organisms multiply enormously in the absence of light and air, and by their aid the organic constituents are reduced to simpler compounds, which finally resolve themselves into water, ammonia, carbonic acid, nitrogenous compounds, and gases. The effluent is generally filtered through clinker and coke breeze.

The Bacteria Tank at Sutton was constructed by Mr. C. Smith, C.E., acting on the suggestion of Mr. Dibdin. The tank is drained with pipes, and ballast (burnt from clay) is filled in on the top of them to the depth of 3 ft. 6 in. The crude sewage is conveyed into the tank, which remains charged for two hours. It is then emptied and the effluent filtered through another tank containing finer materials; the second effluent, being bright and pure, is discharged into a stream. The action of the filter is biological, the bacteria removing over fifty-seven grains of matter per gallon.

Dibdin's Bacterial Filter is the result of many and careful experiments. The filter is composed of coke breeze, and is alternately filled with effluent, and then emptied, and left to aerate itself. The standard of purification obtained is very high, and the contents of the filter are free from putrefying matter, and have the smell of fresh garden mould.

The **Oxygen Sewage Purification** system has been the subject of many favourable discussions before the Institution of Civil Engineers of Ireland, and amongst other places it is in operation at the Dundrum Asylum, at Halifax, and at Northallerton. Mr. Kaye Parry, M.A., B.E., and Professor Adeney first enunciated the guiding principles and have ever since been improving the system and carrying out systematic experiments. The process is briefly as follows:—

After mechanical subsidence the sewage is treated (*a*) by powerful oxidising agents, namely, crude manganese compound; (*b*) the effluent is then treated with nitrate of soda, which furnishes the micro-organisms with the necessary supply of oxygen with which to perform their functions in reducing the effluent to simple and harmless matter.

(a) "Oxynite," which is the manganese compound supplied by the company at market rates, is one of the best deodorising precipitants known. It also has the property of preventing putrefactive fermentation of the organic matters contained in the sludge, and of converting the matters in the latter into the *humus* of ordinary soils. The sludge therefore, becomes a valuable manure, and may be stored without offensive smell. If the process is not being carried out in an agricultural district the sludge may be simply treated and used again as a precipitant, or may be used to render inoffensive the first sludge obtained by mechanical subsidence.

(b) The nitrate of soda really assumes the place of the ordinary filter-bed, which is solely used as a means of supplying oxygen to all parts of the sewage during purification by organisms.

The arduous labours and careful experiments of Messrs. Parry & Adeney have at length produced a system in which no heavy machinery and no large buildings are required, and in the working of which skilled labour takes no part. Moreover, the system is one which is equally applicable to towns, barracks, factories, hospitals, and private houses. No large space is requisite, no fuel for machinery is required, and the only mechanism—namely, a water-wheel—is worked by the flow of the sewage itself. Figs. 143, 144, and 145 illustrate this process as now in operation at Blarney Castle. This installation was erected by Mr. Kaye Parry, and the drawings were obtained through his courtesy. The scheme is as follows:—

The crude sewage, as it enters the works, passes into the bottom of a deep, circular tank by means of a cast-iron pipe, and the liquid rises again to the surface. It passes out by a T-piece connection, and before it enters tank No. 2 it passes over a small overshot wheel (O), by which a regulated quantity of oxynite is added to the liquid by means of a patent automatic feeding machine. The liquid, with the oxynite, passes into tank No. 2, which is similar in construction to tank No. 1.

The solids which are precipitated by the oxynite are retained in the second tank. The first tank merely intercepts

the heavier solids, which are thrown down by sedimentation. The clarified liquid, after leaving tank No. 2, passes into a small rectangular biological tank (C), and at this point a little nitrate of soda is added every day by hand. The

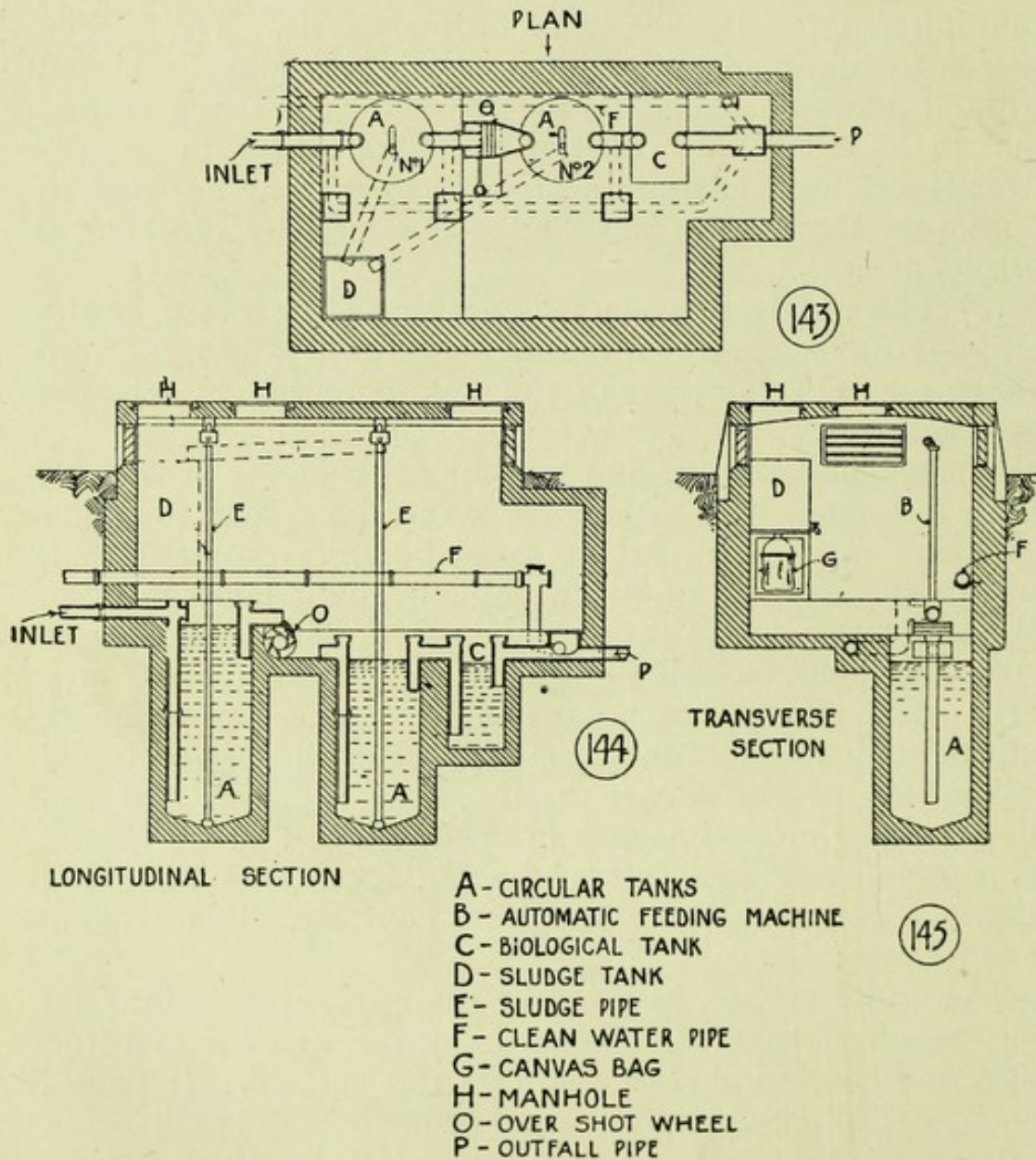

liquid is conducted to a point near the bottom of this tank by a cast-iron pipe (see fig. 144).

The bacterial action takes place in the tank, and the purified liquid passes out through the outfall pipe direct to the river.

The sludge collected in tanks Nos. 1 and 2 is pumped up

by ordinary chain pumps. It is conducted by an open trough into a sludge tank (D) some 2 ft. square, which stands in the corner of the chamber. The sludge is drawn off from the bottom of the sludge tank by a sludge cock connected with a semi-spherical outlet (see fig. 145). An ordinary canvas bag is attached to the mouth of the outlet (G). The sewage, therefore, falls into this bag, the liquid runs off through the canvas and is drained back into No. 1 tank, and the sludge is carried away in the canvas bag to the garden.

The **Sludge** remaining from the various processes is dealt with in different ways, that produced from the Metropolitan works being shipped out to sea in vessels holding some 1,000 tons each. In some cases it is partially dried and ploughed into the land. At Burnley it is dealt with by Johnson's filter press, lime being added during the process. It is carted away by the neighbouring farmers, and has been estimated at a theoretical value of 20s. a ton, while farmyard manure is generally valued at about 15s. It may be observed, however, that the theoretical value of products derived from the treatment of sewage is generally greatly in excess of the value placed upon them by practical farmers, and if the value of such products is so high it is curious that they are seldom, if ever, realised.

CHAPTER X.

TYPICAL DRAINAGE PLANS.

IN commencing this article perhaps a few general remarks will be of value, although most of these have already been previously given.

It should be remembered that among the essentials of a good drainage system are the following :—

1. The rapid removal of sewage, this being governed by the fall of the pipes. This should be carefully attended to, as in the event of the fall being too great the liquids will pass away and leave the solid matter behind. It is generally agreed among experts that a rate of 4 ft. 6 in. per second is a safe velocity, but where a special drain for rain-water is constructed so great a velocity is not necessary, and 2 ft. 6 in. to 3 ft. per second is quite sufficient. It is usually sufficient to allow the following inclinations :—

A fall of 1 in 40 for 4-in. pipes.

Do. 1 in 60 for 6-in. pipes.

Do. 1 in 90 for 9-in. pipes.

2. The careful laying of the drains, so as to ensure their safety in the future. The pipes should be laid on a bed of concrete, and properly jointed with Portland cement as before described.

3. The proper ventilation of the whole system of drainage on the house side; and to ensure this the inspection chamber should have a mica-flap fresh-air inlet, and every soil pipe should be carried up above the roof with an open end.

4. Where possible, and where there is a small amount of water at one's disposal, an automatic flushing tank should be fixed for periodical discharge into the drain. In this can be collected, if desired, the wastes from baths, lavatories, sinks, &c.

5. All rain-water pipes and bath wastes should discharge over gully traps and should be disconnected from the drain.

All soil pipes should be carried direct to the manholes without gully traps, and should be carried well above the roof with an open end.

REFERENCES.

B. Bath Wastes.	R.W.P. Rain-water Pipes.
G. Gully for rain-water pipes, &c.	G.T. Grease Traps.
I.C. Inspection Chambers.	F.A.I. Fresh Air Inlets.
S.P. Soil Pipes.	S. Sinks.
	W.C. Water-closet.

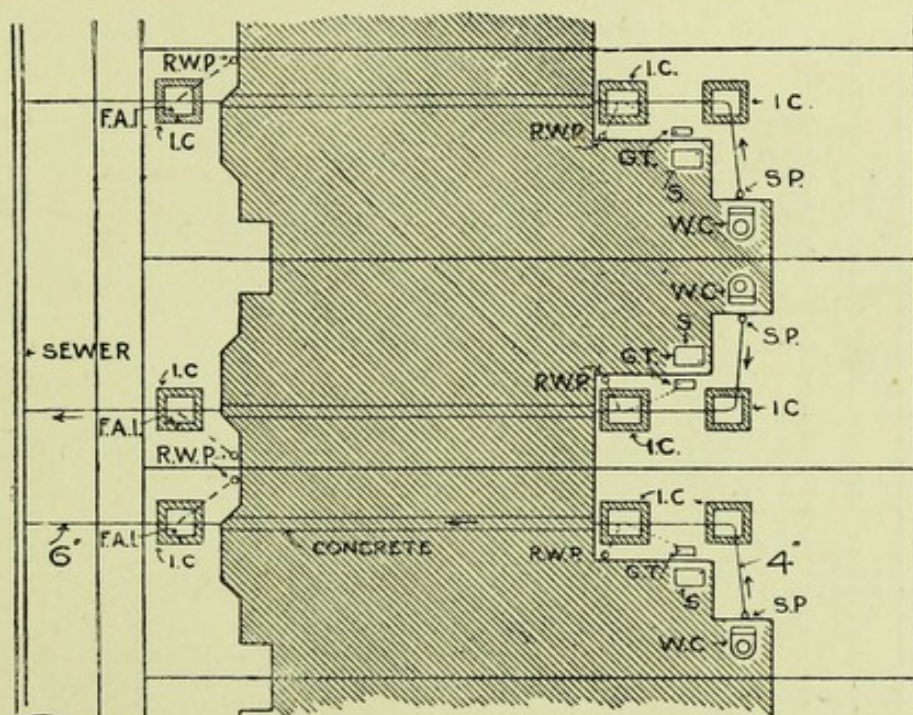

146

TERRACE HOUSES DRAINED TO FRONT STREET

The following typical drainage plans are given :—

- (a) *Terrace Houses Drained towards Front Street.*
- (b) *Terrace Houses Drained towards the Back.*
- (c) *Semi-detached Houses.*
- (d) *Detached House.*
- (e) *Small Stable.*
- (f) *Large Country House.*
- (g) *Town House.*
- (h) *Hospital.*

(a) **Terrace Houses Drained towards Front Street.**—First, we deal with a system of drainage which is often met with in the erection of terrace houses.

In this system it will be noticed by reference to fig. 146 that the drainage empties itself into the sewer laid in the front street, thus necessitating the laying of drain pipes underneath the house. It has already been pointed out in a previous chapter that this is a system which should be avoided, wherever possible, because of its several disadvantages, but in this case it is impossible to use any other

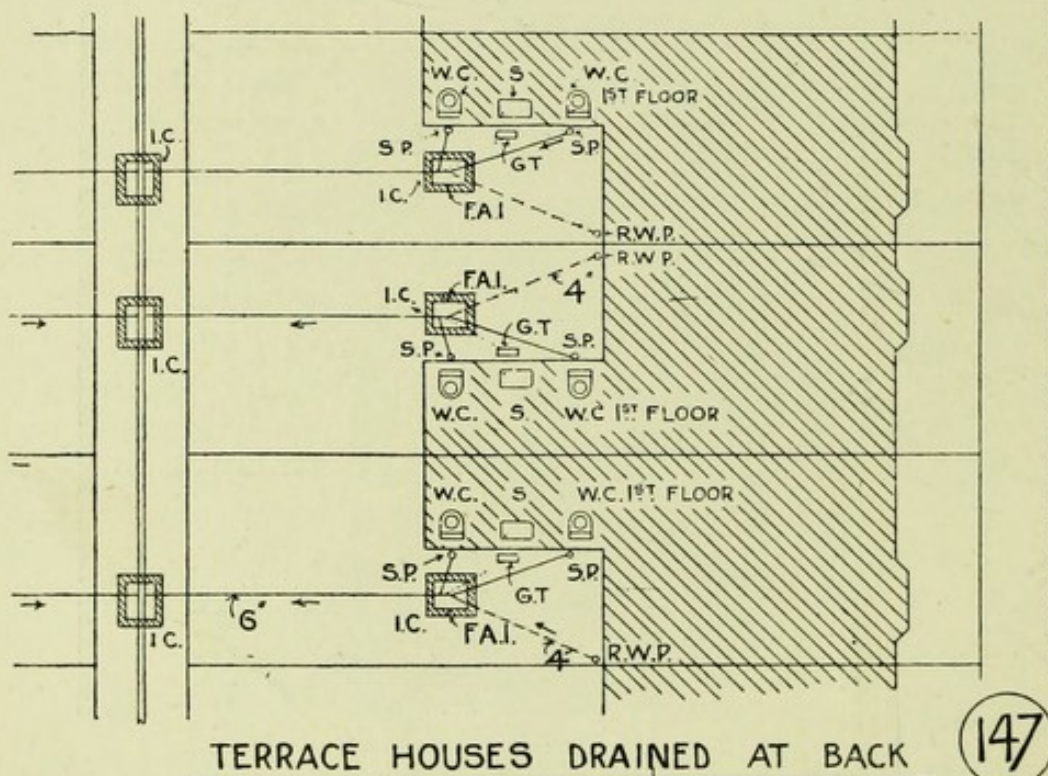

system. It should be noted that precaution to a large extent has been taken by embedding the pipes in concrete, so as to give additional security against the entry of sewer gas into the house. The drainage to be dealt with in this case is a soil waste, scullery sink waste, and the rain water. A reference to the diagram will show how this is effected. Attention need only be drawn to the fact of the necessity of laying the drains in a perfectly straight line, from the house to inspection chamber, and from thence to the sewer. Where the pipes pass through an inspection chamber they

should be of half or three-quarter section. Illustrations of these have been already given in previous chapters. A fresh-air inlet is shown at the lowest point of the drain introduced into inspection chamber. The soil pipes in all cases would be carried up well above the roof and covered with a wire cage.

(b) **Terrace Houses Drained towards the Back.**
—Fig. 147 shows a system of drainage in which the sewer

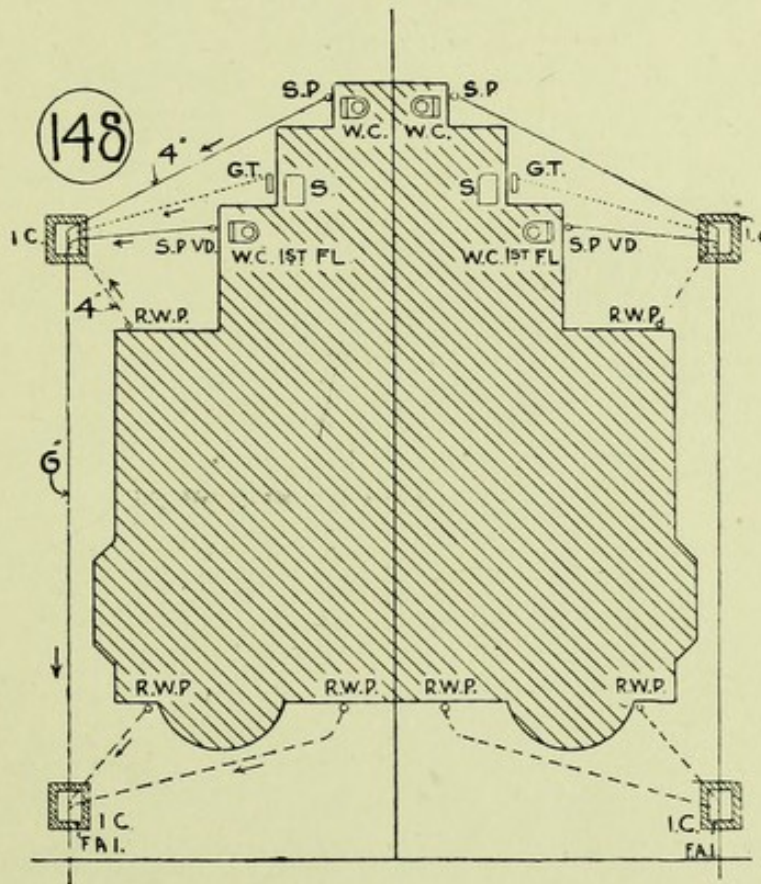

SEMI - DETACHED HOUSES

is at the back of the house, thus enabling the sewage from the other side of the street to be discharged into the same sewer. This arrangement does away entirely with the objectionable practice of carrying the drain pipes underneath the house, with all the attendant trouble and expense in case of anything by chance going wrong. With the drainage under the house it is necessary to break up the floor and the concrete to enable one to get at the obstruction. By

referring to the diagram it will be observed that each house has an inspection chamber, into which the soil and rain-water pipes, &c., are taken; from thence the pipes have a clear run down to the sewer, at the junction of which a further inspection chamber is placed. It will be noticed that in case of a blockage a man would find no difficulty whatever in reaching any part of the drainage system with

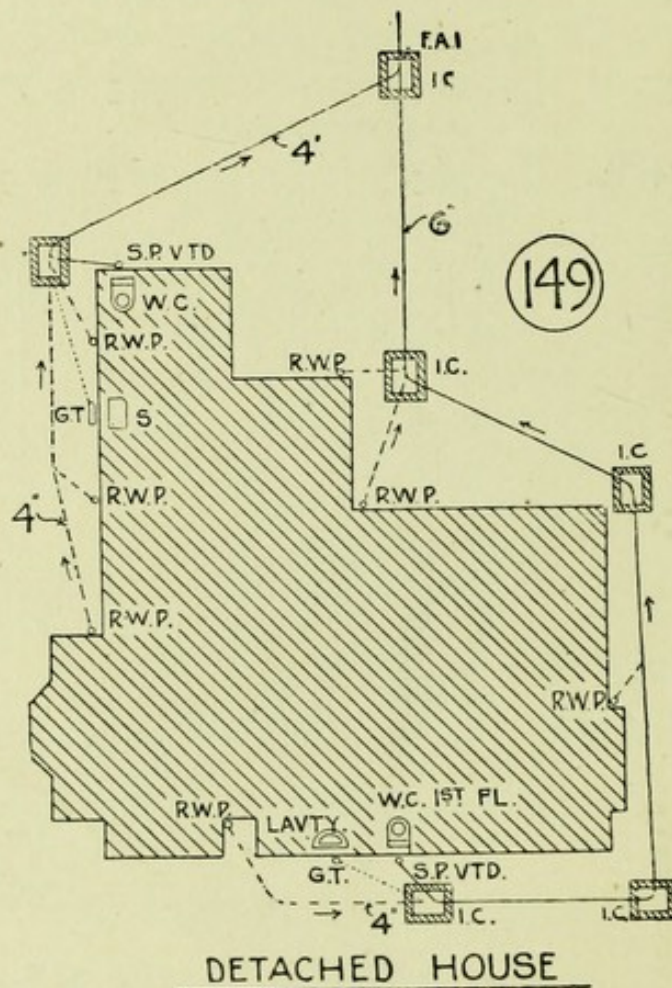

his drain rods, and thereby removing easily and quickly any obstruction.

(c) **Semi-detached Houses.**—The next system to come under our notice is that required for semi-detached houses, which is illustrated in fig. 148. By reference to it, it will be seen that each house is provided with two inspection chambers for the purpose of reaching the branch drains. The planning of these follow out the principles

already laid down, namely, that they should be laid in a perfectly straight line with easy bends, so as to help the flow of the sewage into the proper direction to reach the sewer. Care should be taken that the bends should not be abrupt, and that no sharp angles should occur so as in any way to impede the flow of sewage and thereby cause a stoppage. It should also be noted that, where possible, as many junctions should be made in the manholes, so that in case of defects any part of the system can be reached from these.

(d) **A Detached House.**—Our next illustration is for a detached house, shown in fig. 149. It will be noticed that, owing to the shape of the building, and of the fact of

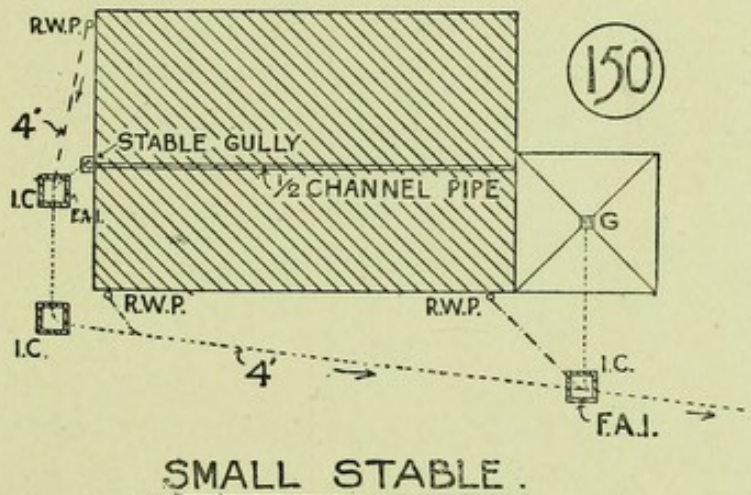

the sewer being at the back of the house, a larger number of inspection chambers are necessary than in any of the previous examples.

It shows the necessity of planning the house as much as possible so that the sanitary arrangements are placed near each other. This is often difficult to manage, but it should be the architect's aim.

(e) **A Small Stable.**—Fig. 150 shows the drainage of a small stable. It will be noticed that a half-channel pipe, 6 in. in diameter, runs the whole length of the stable with a sufficient fall towards the stable gully to carry off all water and other liquids. Of course, the stable floor itself has a slight fall towards this pipe. A gully should be

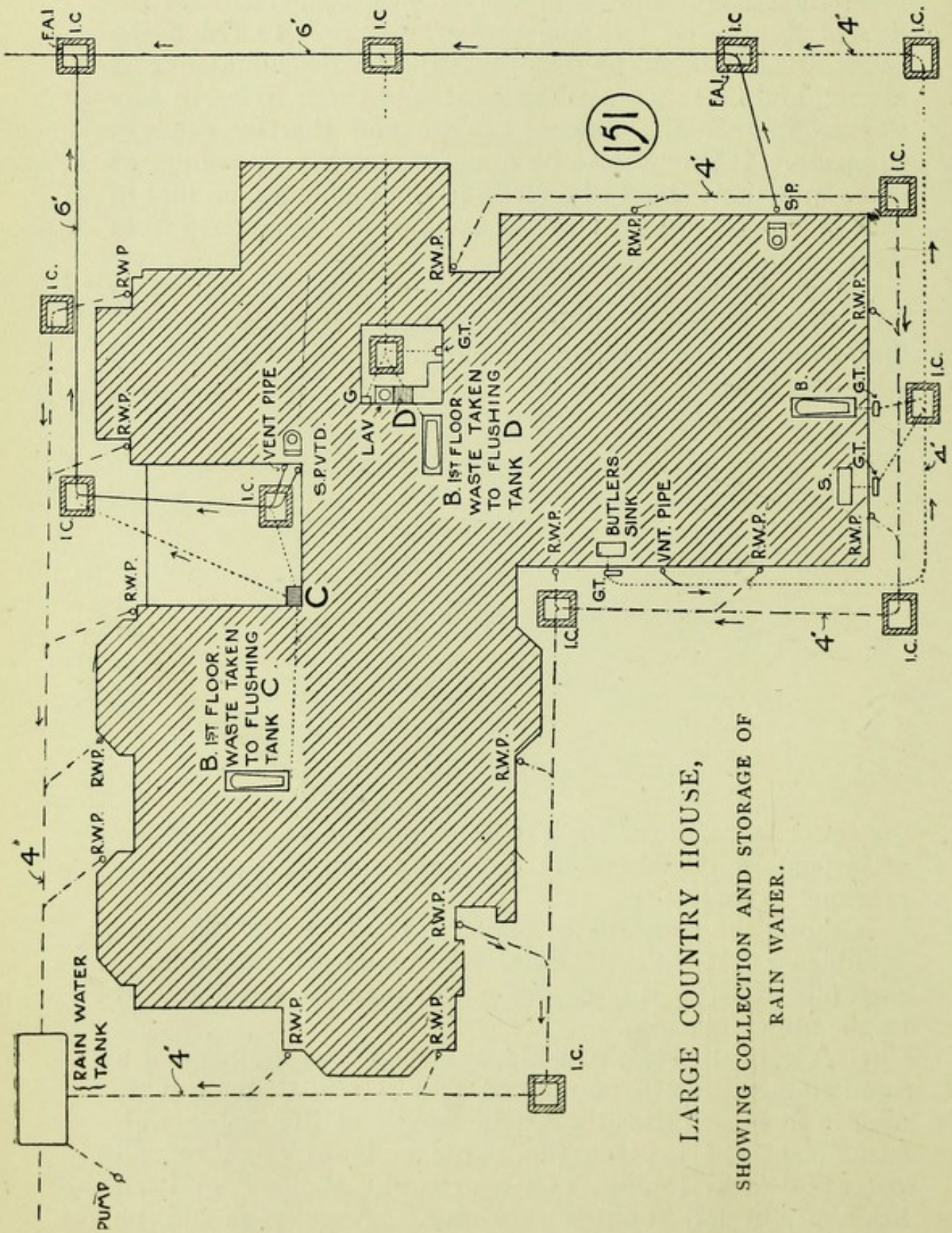

LARGE COUNTRY HOUSE,
SHOWING COLLECTION AND STORAGE OF
RAIN WATER.

provided with a proper grid so as to intercept all straw and other refuse that might be carried down the channel and thence into the drain. On the right of the stable will be noticed a small washing-place for carriages with a gully in the centre. The flooring of this space should be laid to a fall towards the gully. The water from this portion and the stable is then collected into the inspection chambers and from thence to the sewer. A fresh-air inlet is provided at the lowest manhole.

(f) **Large Country House.**

—Fig. 151 shows us a method of draining a large country house. It will be noticed by reference to the plan that the rain water is stored in a tank which is connected to a pump; this arrangement is very convenient in neighbourhoods where there is not a plentiful supply of water, or where the rain water can be utilised for domestic purposes. It will also be noticed by referring to the diagram that the waste from the baths is collected into automatic flushing tanks marked D and C, which discharge their contents at regular intervals into the drains, thereby tending to keep them clean and sweet.

(g) **A Town House.** —

Fig. 152 shows a method of draining a modern town house. In such it is generally necessary to carry the drains for some distance under the house. It will be noticed that the drainage in this case consists of water-closets and lavatories from ground floor, bath-room, second floor, and a water-closet from third floor.

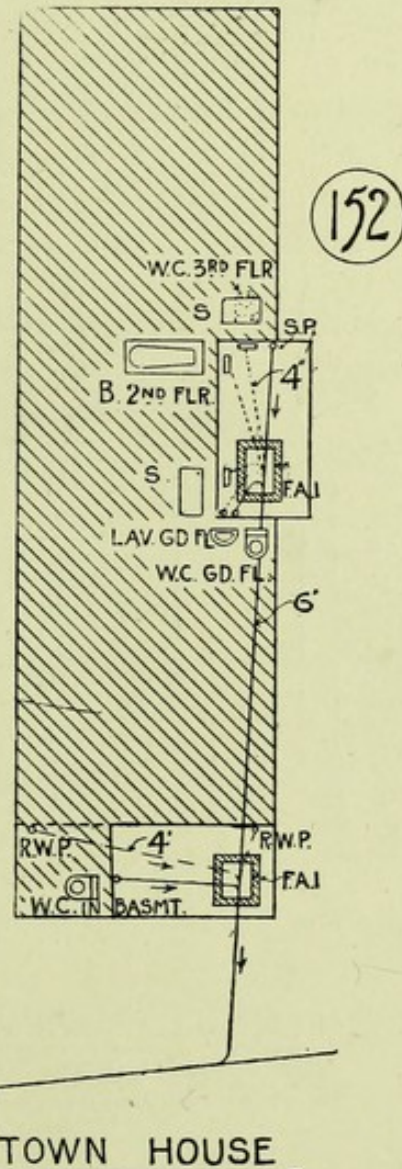

TOWN HOUSE

The drainage is all connected into one manhole and is easily accessible from it. The drain is then carried under the house. This portion of the drain should be 6 in. in diameter. If of glazed stoneware, it should be laid on a 6-in. bed of concrete and encased all round with 6 in. of the

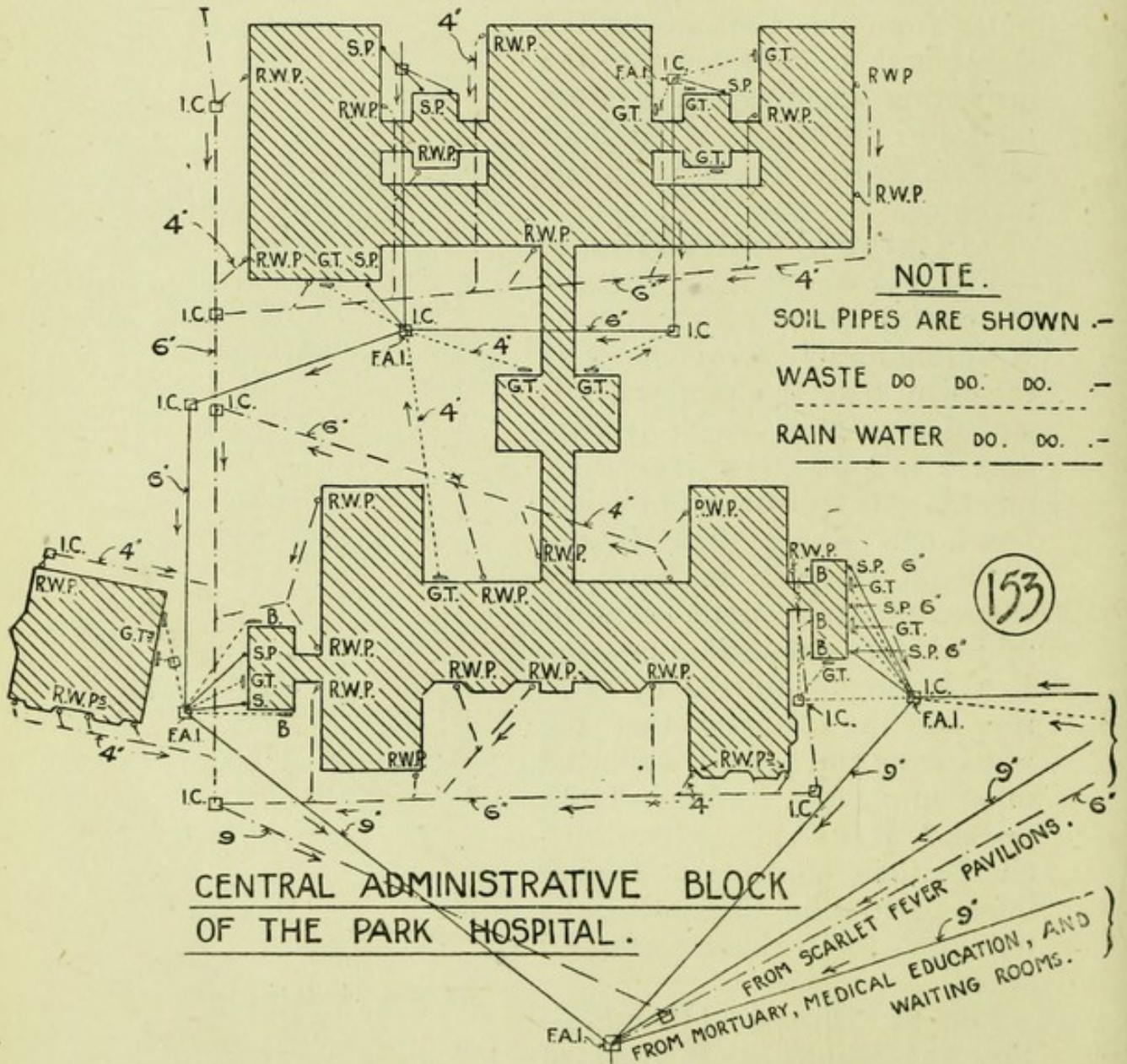

same material. Some architects prefer heavy cast-iron pipes for under house drainage, but there is always the difficulty of prevention of rust, even when preventative solutions are used. The advantages of iron piping are that it can be obtained in longer lengths.

Iron pipes lined with glass or with a lead lining can also be used.

(h) **A Hospital.**—Fig. 153 shows the system of drainage adopted in the administrative block of the Park Hospital, and is produced here by permission of Mr. Edwin T. Hall, the architect of the building. It will be noticed that in this plan also the rain-water is kept separate from the other drains, but it will be seen that the main line of the rain-water drainage is discharged into the last inspection chamber, no attempt being made to collect it for use.

The wastes from scarlet-fever pavilions and offices are also emptied into this inspection chamber before discharging into the sewer.

In draining a building of this description it should have careful thought and consideration, as unnecessary expense and trouble can be avoided by so doing, and what looks at first sight to be a very complicated plan is really thoroughly simple and efficient.

CHAPTER XI.

WATER SUPPLY AND POLLUTION.

WE may consider this subject under the following headings :—

1. *Sources.*
2. *Physical Properties.*
3. *Consumption of Water.*
4. *Impurities.*
5. *Examination of Water.*
6. *Storage of Water.*
7. *Hardness of Water.*
8. *Distribution of Water.*

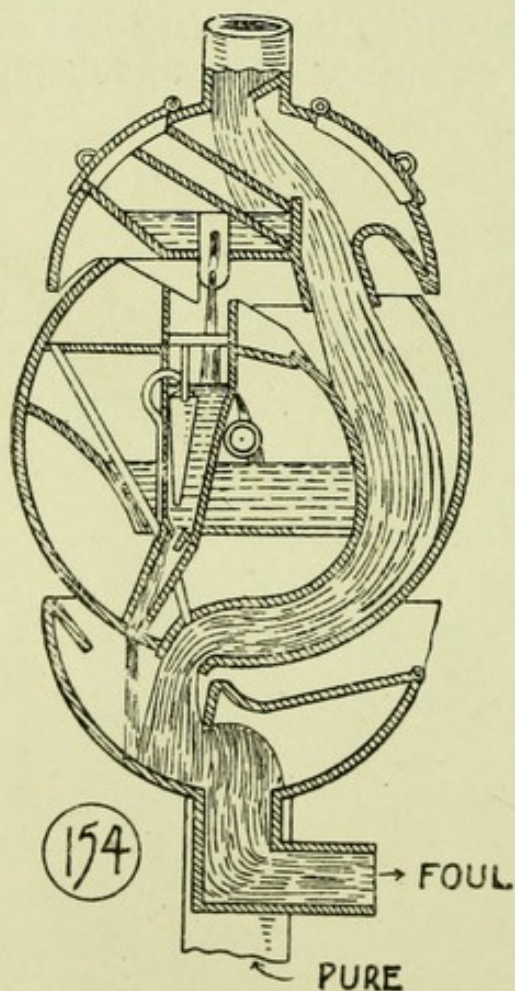

1. **Sources.**—The origin of all sources of water supply must be the rainfall, though the actual method of supply may be by (a) *rain water*, (b) *lake water*, (c) *river water*, (d) *spring water*, (e) *well water*.

(a) **Rain Water** itself is pure, and where it comes but little in contact with injurious gases and matter it is the best form of supply. This, however, but seldom happens, except in sparsely populated and rocky districts. The amount of rainfall varies in different districts from under 25 in. to over 80 in. in the British Isles, the lowest average fall being about the South - Eastern Counties of England and

the highest being the Western part of Scotland. Part of the rainfall sinks into the ground, part is evaporated, and part is

carried along the surface of the ground and fills the rivers and lakes, &c., in the neighbourhood. Rain-water should never be allowed to run to waste, as it is most agreeable for washing purposes, and, in some instances, it has to be used

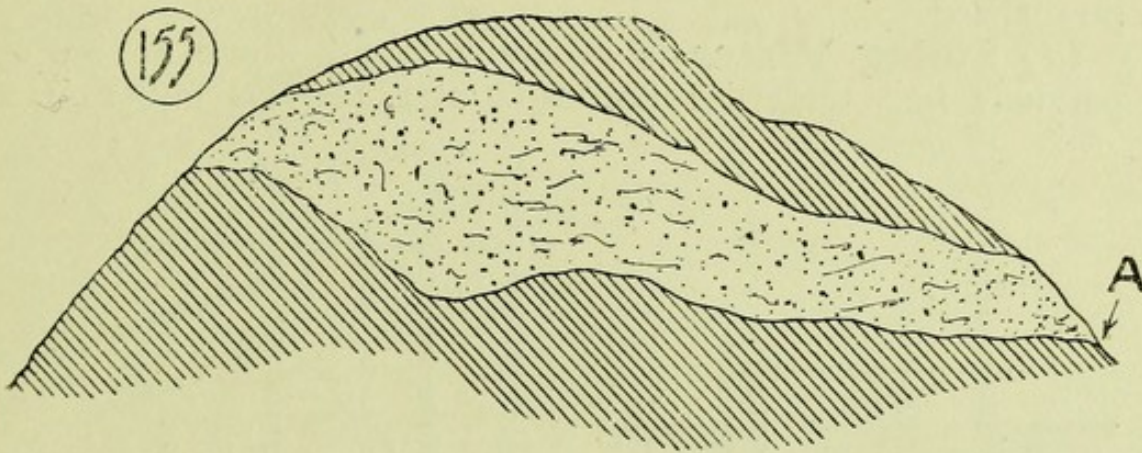

for dietetic requirements, notably in Holland, where collecting areas are specially prepared.

Fig. 154 shows the section of **Roberts' Rain-water Separator**, which runs the foul water to waste, and when the roof has ceased to deliver foul water the canter is over-balanced and the clear water runs to storage.

(b) **Lake Water** derives its source of supply from the surface water previously mentioned, and also from springs,

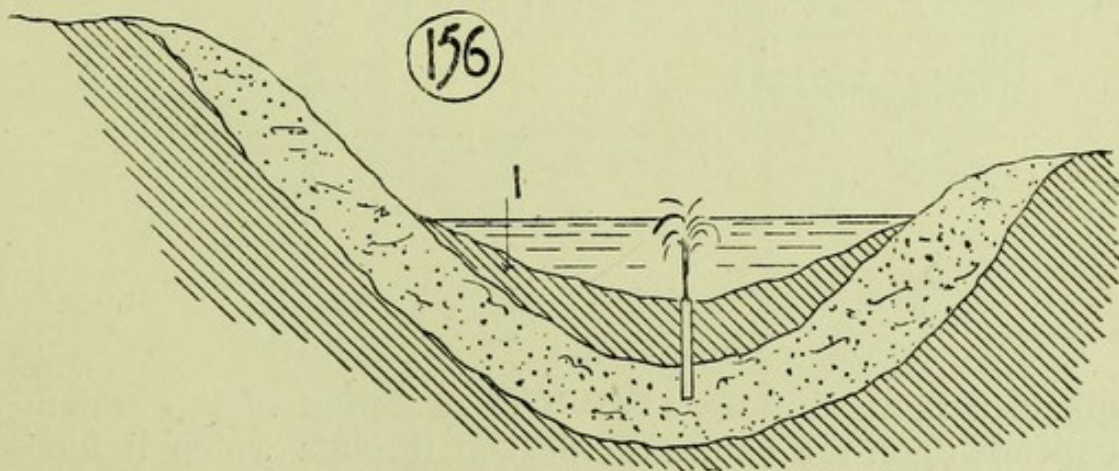

and is liable to have foreign matters in suspension and solution.

(c) **River Water** is derived from the same sources as lake water. Rivers are very liable to pollution, owing to

the drainage from manured farm land, and to animal and vegetable impurities being washed into them. When, in addition to these, sewage from towns and villages and trade effluents are added, the danger of this form of supply may be realised.

(d) **Spring Water** is generally found where an impervious bed underlies porous strata, and [an outlet is

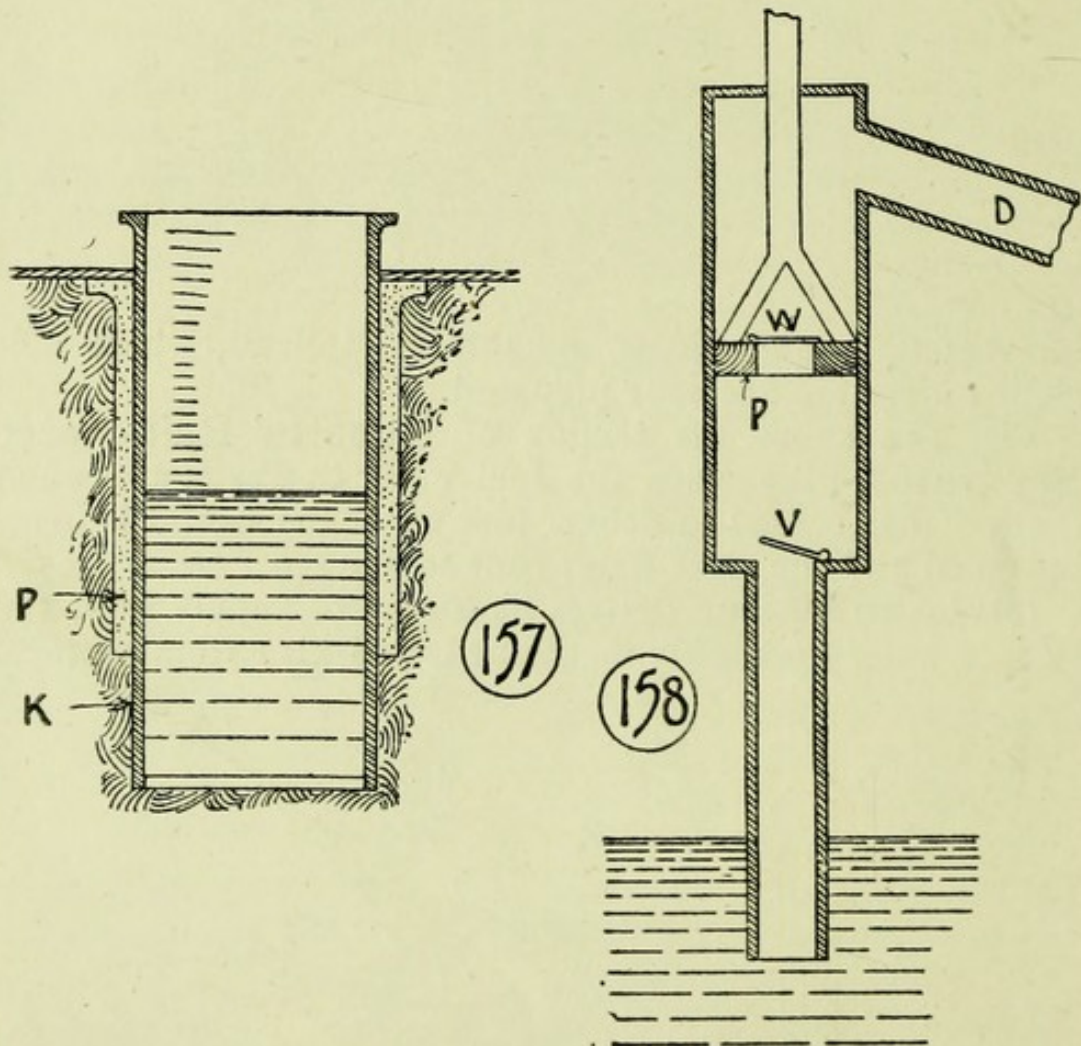

obtained as at A in fig. 155. The condition of this water depends upon the nature of the soil through which it has passed.

(e) **Well Water** may be either from shallow or deep wells, that from the former being very liable to pollution from organic matter washed through the soil. An impervious lining (steining) should always be used as deep as practicable

to minimise this risk, as shown at K in fig. 157, the lining also being taken above the surface to prevent any matter flowing in from the top. A cover should also be provided. The water should be drawn up by a pump if possible (three forms of the latter are shown in figs. 158, 159, and

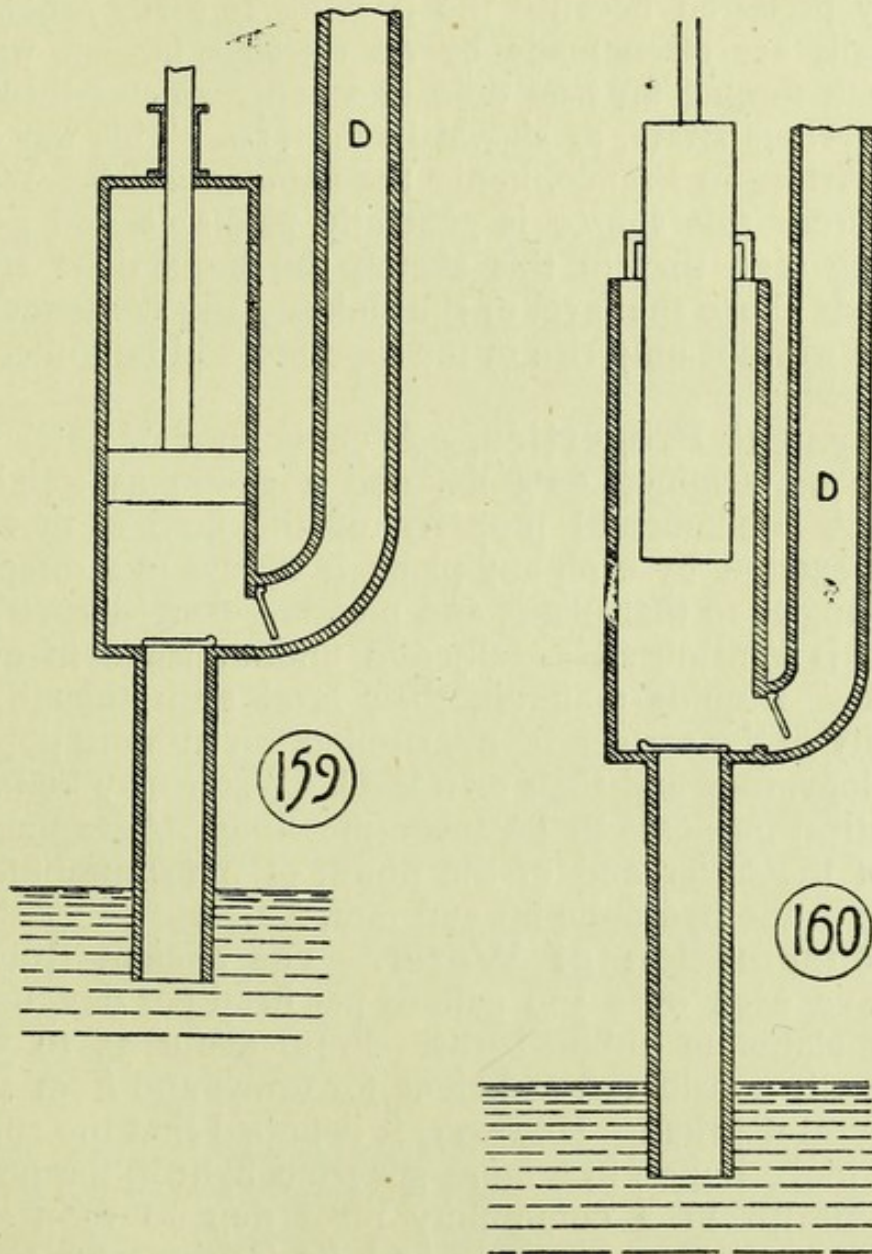

160), and not by a bucket and rope, as these are liable to become foul and to taint the water. Fig. 158 illustrates a section of an ordinary **lifting pump**. As the piston P is raised, the valve V is opened and water is drawn up into the cylinder, and at the next stroke it is drawn through

the valve W, and is conducted to the delivery pipe D. Fig. 159 is a section through a **force pump**, and it will be noticed that the piston is solid, and the water after being raised in the cylinder is forced up the delivery pipe. Fig. 160 is a force pump with a plunger in lieu of a piston, and is generally preferred because the packing is easily renewed. Deep wells are often made by an artesian boring, which consists in forcing an iron tube of small diameter through the impervious strata, as shown in fig. 156. This was first done at Artois, in France, hence the name *artesian*. Water derived from this source is generally palatable and good. It will be seen that in this sketch the impervious strata (I) extends above the level of the sinking, and consequently the water will not only rise in the pipe but will be forced up to overflowing.

2. **Physical Properties.**—A cubic foot of water may be taken as weighing 62·5 lb., and a gallon as weighing 10 lb. A fundamental property of the fluid is that the pressure exerted by it on any plane is always in a direction at right angles to that plane, and pressure exerted anywhere on water is transmitted equally and undiminished in every direction. Liquids maintain their level even though the continuity of the surface be interrupted, or, in more popular phraseology, they find their own level. Water may be taken for practical purposes to be incompressible. Advantage is taken of the latter and of the power of transmittability of pressure in the hydraulic lift and ram, &c.

3. **Consumption of Water.**—The ancient Romans must have used over 300 gallons per head per day, owing to their elaborate public baths. From about 35 to 50 is now usually considered sufficient for towns and from 20 to 25 for rural districts. However, it is hoped that the supply will be looked upon in a more generous light in the future, as the health of a community must depend to a large extent upon its water supply and its facilities for taking baths. The following table gives the daily average number of gallons per head in several cities :—

Washington	158
Middlesbrough-on-Tees	140
Karlsruhe (Germany)	130

New York...	100
Chicago	75
Montreal	55
Glasgow	50
London	35
Paris	28

4. **Impurities.**—Water nearly always contains foreign matter in suspension and solution, absorbed gases, microbes,

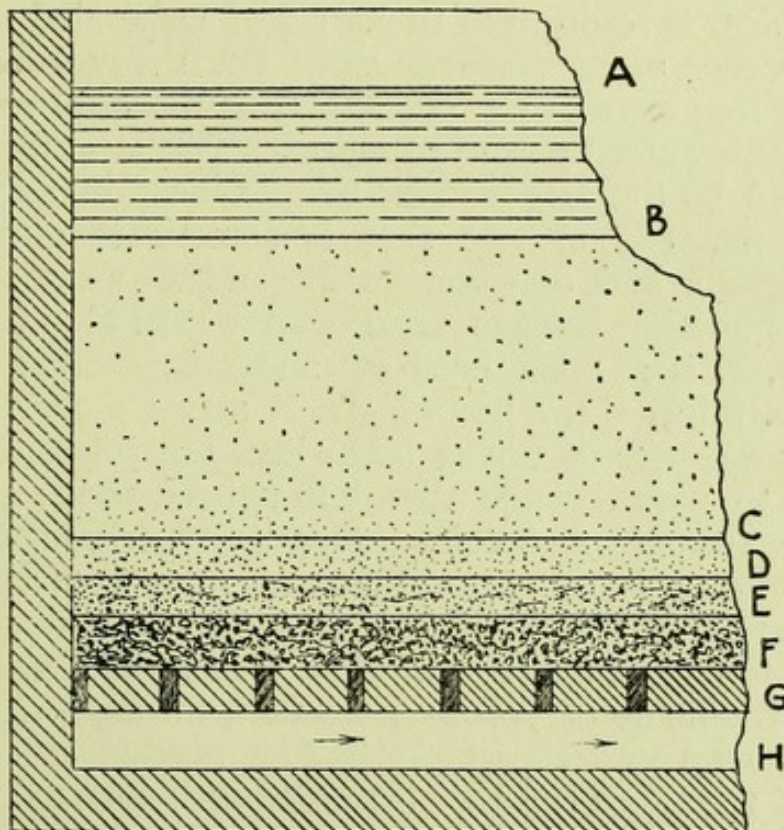

(161)

and other living organisms. Water for dietetic purposes must not contain more than a certain percentage of these impurities. Matters in suspension may be removed by filtration and settlement, those in solution by distillation, aëration, precipitation, and nitrifying organisms. Absorbed gases may be expelled by boiling and distillation, living organisms may be reduced by filtration and settlement, &c.

Distillation is effected by evaporating water and

condensing the steam. Distilled water is unpalatable, but on aëration it becomes less unpleasant; this latter may be accomplished by exposing it to the air in thin streams.

Boiling removes temporary hardness and destroys microbes, but the water requires aëration afterwards, as it is unpleasantly flat.

Nitrification is the process by which, owing to the action of microbes, nitrogenous organic matter is oxidised with a formation of nitrates.

Filtration is resorted to to get rid of suspended matters and to oxidise organic substances. Dr. Percy Frankland has shown that over 95 per cent. of microbes were removed from Thames water by sand filtration. The sand filters are mostly used by the larger water Companies. A section is shown in fig. 161 of one that is sometimes employed. C represents a bed of clean sharp sand about 3 ft. 6 in. thick, D is another layer of sand coarser than C and about 4 in. deep, E is another layer of sand coarser than C and about 3 in. thick, F is a bed of gravel about 6 in. deep, G represents a course of bricks laid with open joints to allow the water to pass through to the trough H, which conveys it to the storage reservoir. Magnetic carbide of iron covered with a layer of sand has also been successfully utilised for filters, but this must be used on the intermittent principle, to allow of aëration. The **Pasteur Chamberland** filter is made of porous porcelain, through which the water is forced under pressure. The residue left on the outside of the tubes can be easily removed, and by heating them periodically they may be sterilised. At Darjeeling 9,500 of these tubes are in use in thirty-eight cells in the municipal waterworks, and supply 150,000 gals. a day.

Household filters, until quite lately, were almost solely designed for the purposes of removing suspended matters, to lessen hardness, and to reduce the danger of organic matter. In recent years, however, the removal of micro-organisms has been found to be essential, and it was then discovered that most of the old filters were simply breeding-places for these germs, so that, instead of removing them, they were actually increased to an enormous extent. The Berlin Inquiry of 1886 did much to remedy this evil;

and the inquiry for the German War Office, in 1895, by Dr. Plagge gave great prominence to the **Pasteur Chamberland** and **Berkefeld** filters. These latter have now sealed the fate of the older forms of filters, and this type of porcelain candle is now recognised as being the one on which future developments must be based. They require pressure to work efficiently, and consequently are termed "pressure filters." Fig. 162 shows a section of the **Berkefeld**. The water supply is connected by the tap W, and flows into the outer covering, which is of enamelled iron, and through the hollow cyclinder C (of porcelain or kieselguhr), and from the interior of which it is delivered to the outlet pipe O. By means of the thumb-screws SS the candle of porcelain may be removed for cleansing or may be sterilised by boiling.

5. **Examination of Water.** — The following simple tests may be made by any one. Samples should be collected in long tubes, 2 in. or 3 in. in diameter, which latter have previously been well rinsed out with a little acid, and then several times with the water which it is

desired to examine. If river or lake water is the subject of the inquiry the samples should be taken at various points and beneath the surface, and a note should be made in each instance of the exact locality from whence they are taken. The tubes should be well stoppered and placed in the light, but an inch or two should be left from the surface of the water to the underside of the stopper. They should stand for twenty-four hours, and then be examined to see if vegetation is encouraged; this can be detected by the smell. If this is not apparent, slightly warm the tubes and test them again. A similar tube should be filled with distilled water

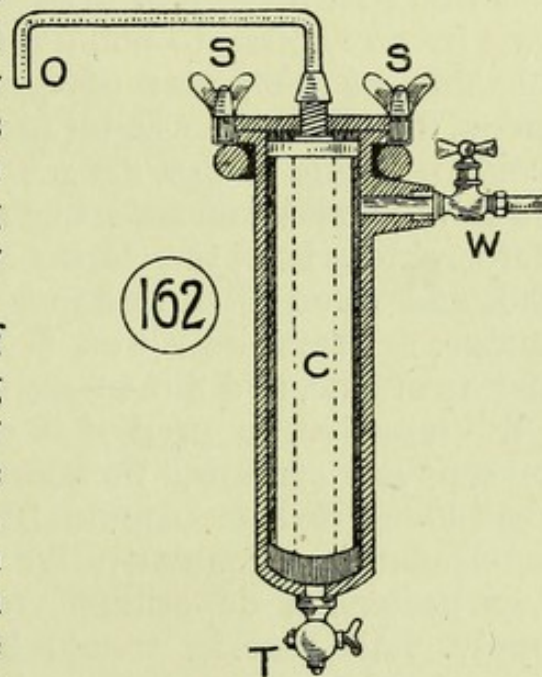

and placed alongside the others on a sheet of white paper, and the colour compared. If a drop of Condy's fluid (permanganate of potassium) be placed in the water, and it becomes bleached in a short time, it is a sign of the presence of organic matter. A portion of the water may be evaporated, and the residue burnt; if it blackens it indicates the existence of animal organic matter. If a sample of water is put on a gelatine film resting on a plate, organisms multiply rapidly and are easily discernible under the microscope.

6. **Storage of Water.**—This is best accomplished, if it can be so arranged, in underground tanks, in which there must be no liability to pollution. It is thus rendered more palatable by its power of assimilating carbonic acid gas under the ground. Domestic cisterns of lead are to be avoided, owing to the danger of the water carrying away the soluble oxide of lead due to the presence of oxygen. Hard water, however, forms a protecting surface on the lead, and there is little danger in using this metal for its storage. Galvanised iron is simply iron covered with a coating of zinc, and most waters will dissolve this; it should not, therefore, be used if it can be avoided. Slate and earthenware cisterns, therefore, should be used where possible. Provision should be made so that cisterns may be cleaned out regularly, for it must be remembered that they become a depositing ground for impurities in the supply. All cisterns should be covered to prevent their pollution by dust, dirt, and possibly dead birds, and they should be ventilated, and have an overflow pipe, with its open end as far from any sewer or drain as possible.

7. **Hardness of Water.**—This may be either temporary or permanent. **Temporary hardness** is due to the presence of calcic and magnesian carbonates and may be overcome by boiling, which expels the carbonic acid and precipitates the carbonates. **Permanent hardness** is due to calcic and magnesian sulphates, which boiling does not affect. Hard water will not dissolve soap but precipitate it; hence the soap test is now usually employed for determining the hardness of water. Every grain of calcic

carbonate or its equivalent in one gallon of water constitutes one degree of hardness.

The effect of hard and soft water on the health is a much debated point, but from an economic point of view, soft water is much preferable, and it is said that in Glasgow, since the soft water supply from Loch Katrine was introduced, a saving of over £30,000 in soap has been effected per annum. Hard water also causes lime deposits in boilers, kettles, and hot-water pipes; it is unpleasant for domestic use as it produces roughness of the skin. Dyspepsia, gravel and stone in the bladder, and swellings of the glands have also been attributed to its use. The late Sir Douglas Galton suggested that 10 deg. of hardness would satisfy the general requirements of a town supply. Dr. Clark's process for removing temporary hardness consists in the addition of lime, by which means the bicarbonate of lime in the water is reduced to a carbonate, which latter is precipitated. At Luton Hoo the hardness of the water is reduced from $18\frac{1}{2}$ deg. to 4 deg. by this process, and 70,000 gallons can be softened per diem. Permanent hardness of water at Penarth is reduced from 18 deg. to 6 deg. by the addition of 22.5 lb. of lime, 5 lb. of soda, and 1 lb. of alum to every 10,000 gallons of water. Clark's process consists in the addition of 1 oz. of quicklime to every 100 gallons. The Porter-Clark system is a modification of this, the precipitated calcic carbonate being removed by cloth filtration under pressure, thus avoiding the delay of slow subsidence.

8. Distribution of Water.—This is effected either on the constant or intermittent principles. Every water company should be compelled by the legislature to provide a constant supply, as it is not only more conducive to health, but in the case of outbreaks of fire the lack of water is a very serious matter. Even with the constant supply, however, it is wise to have a small supply cistern, as the water is sometimes necessarily cut off for repairs to mains and other causes. Water mains are frequently not laid sufficiently deep below the surface, and consequently are liable to be affected by heat and by frost; they should not be less than 4 ft. below the ground level. The pipe mains are usually of iron, coated with

bitumen, magnetic oxide, or some preservative solution. The best method is to have a glazed lining, but this is, of course,

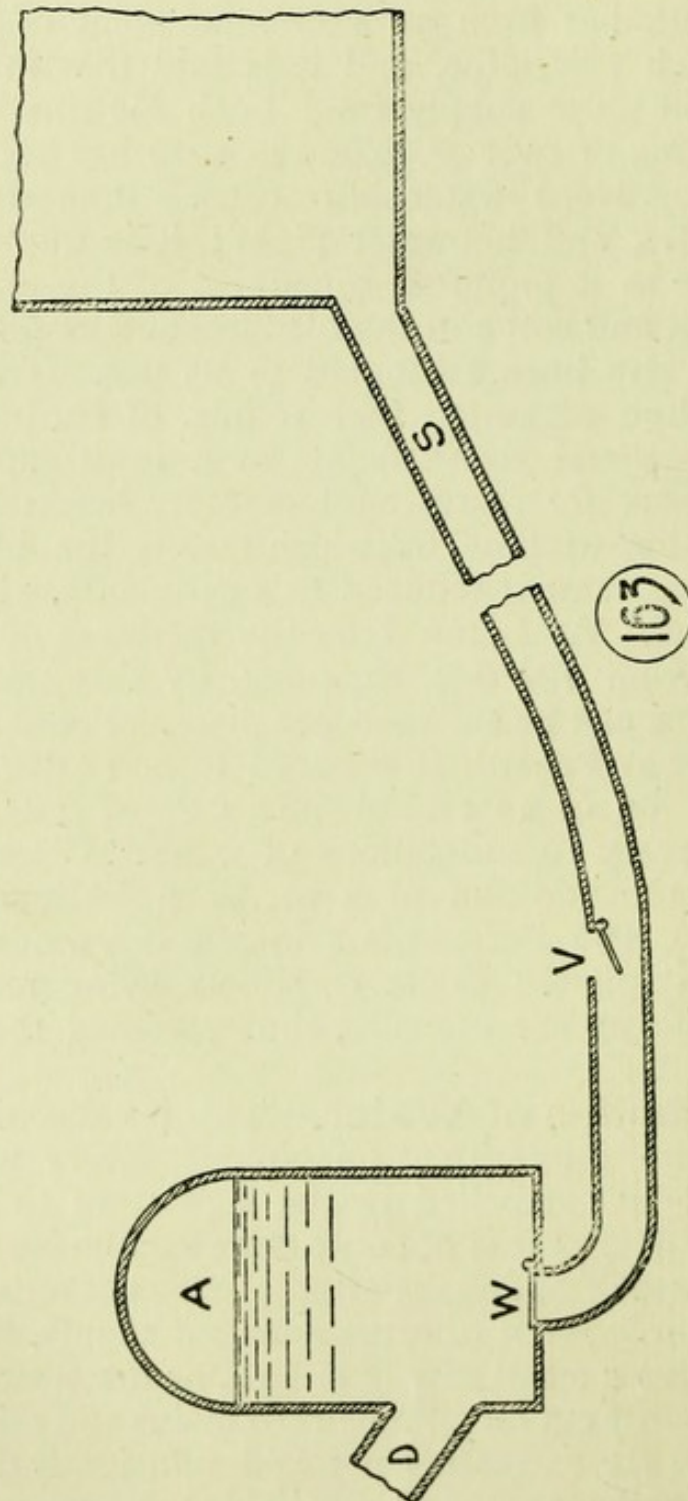

somewhat costly. Lead pipes are most often used inside the house owing to their preference by the water companies ;

but, as previously mentioned, the lead is liable to be dissolved by the water if the latter is of a soft description. If possible, it is always best to use pipes lined with either glass or tin. Stopcocks should be arranged so that any branch supply may be cut off from the main, and all pipes should be run so that there is no danger of frost affecting the water-supply. If, in any case, it is found necessary to have them outside the building, they should be covered with asbestos felt, or other non-conducting material.

All water for drinking purposes should be drawn direct from the main supply pipe.

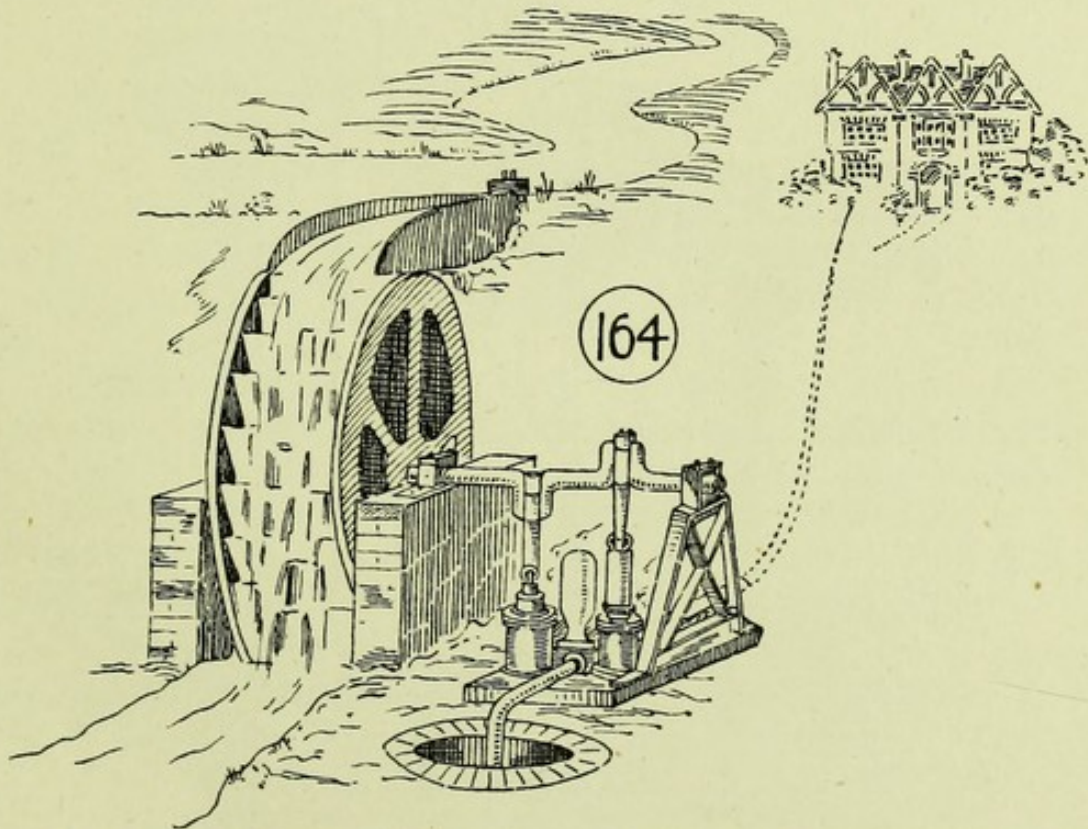

In country houses it frequently happens that no spring or supply exists above the level of the house, and, consequently, the water has to be raised by mechanical means. One method often employed is the **Hydraulic Ram**, whose action is as follows:—A supply pipe, S, in fig. 163, is taken from the reservoir to the air vessel A (or ram). A finely-balanced valve is fixed at V, whose weight is a little greater than the water pressure from the reservoir. Hence when the water is at rest in the supply pipe the valve V opens

downwards and water runs to waste. As the velocity of the water increases, the valve V is closed, and the momentum opens the valve W, and water is thus forced into the air vessel; the air in the latter is compressed, and by its reaction the water is forced up the delivery pipe D. The pressure in the supply pipe is thus diminished, and both

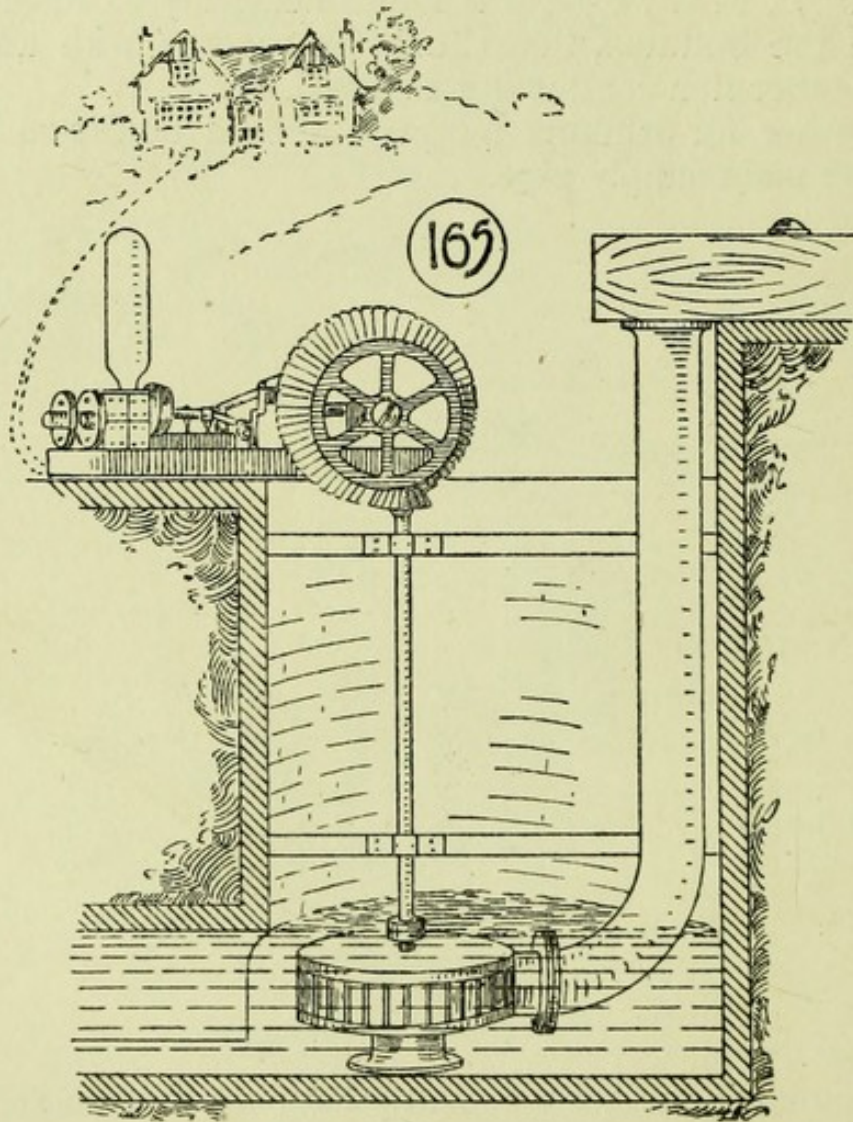

valves therefore fall and the water escapes at V until this valve is again closed by the impact of the water due to the increased velocity, more water enters the ram and is raised higher in the delivery pipe. This action is continually repeated while the supply in the reservoir is maintained. It is estimated that about one-eighth of the water is wasted.

The following formula and notes on the hydraulic ram may be of use. When :—

Q = quantity of water used in cubic feet per second.

h = head of water in feet (*i.e.*, difference in level of reservoir and ram).

P = effective horse-power.

$$\text{Then } Q = \frac{14.7 P}{h}$$

and $P = .068 Q h$.

The length of the supply pipe should not be less than three-quarters of the height to which the water is to be raised.

The diameter of the supply pipe should be equal to $1.45 \sqrt{Q}$, and the diameter of the rising pipe should equal $.75 \sqrt{Q}$.

The contents of the air vessel should be the same as the contents of the rising tube. One-seventh of the water may be raised to four times the head of the reservoir, or one-fourteenth eight times, or one-twenty-eighth sixteen times, &c.

A greater fall than 10 ft. is to be avoided as it involves too much wear and tear on the valves. **Water-wheel** driving pumps, both over-shot and under-shot, may be used for this purpose of raising water, and fig. 164 shows a sketch of one used by Messrs. Merryweather & Sons. **Turbine** driving pumps are also used, as shown in fig. 165. Arrangements may also be made when fixing this latter for driving electric lighting, laundry, and refrigerating machinery.

CHAPTER XII.

WATER SUPPLY FITTINGS, etc.

WE will now briefly consider the means of connecting and controlling the water-supply to the house under the following headings :—

1. *Connections to Main.*
2. *Underground Cisterns.*
3. *Unions and Junctions.*
4. *Taps and Fittings.*

1. **Connection to Main.**—The inconvenience of having to shut off the water supply and empty the main pipes each time a new connection is required has caused the production of several machines designed to enable a service pipe to be connected to the main while the pressure is unreduced in the latter.

Fig. 168 is a section of such a machine. It is in the form of an oblong box of cast-iron fitted to the curve of a 6-in. pipe. It is held on the main to be "tapped" by two chains drawn very tightly round the main pipe by means of long screw-bolts and nuts. A rubber washer between the flange of the machine and the pipe makes a water-tight joint. It is held down by four fly-nuts on bolts passed through slots, which enable the lid to be moved backwards and forwards by means of a lever. In the lid are two holes fitted with stuffing-boxes. The holes are exactly the same distance apart as the length that the lid can be moved by the lever. Through one hole in the lid is passed the stem of a combined drill and tap, which, being rotated by means of a ratchet and pressed down by a screw, drills a hole through the pipe. The stem of the drill forms the tap, and the hole is drilled and tapped by the one operation.

The arm is then withdrawn, the thumb-screws holding down the lid are eased, the lever drawn over as shown by the dotted lines, and the thumb-screw is tightened. The second hole in the lid is now over the hole in the pipe.

Through this hole, before the lid was put on, the stem of a rimer was pressed, which latter was previously wedged into one end of a closed stop-cock. By the movement of the lever this is brought directly over the hole of the pipe. It is pressed in and screwed up, and the machine is taken off, leaving the stop-cock screwed into the water-main. A slight leakage will occur while the thumb-screws are eased and the lid is being moved, but the boxful of water should be all the loss of water that occurs during the operation.

Another method of tapping the main is shown by fig. 169, which is a diagrammatic sketch of a smaller and more portable and altogether more convenient instrument. It is made in two halves, which are joined by a rubber joint longitudinally. It is circular in plan and is held on to the

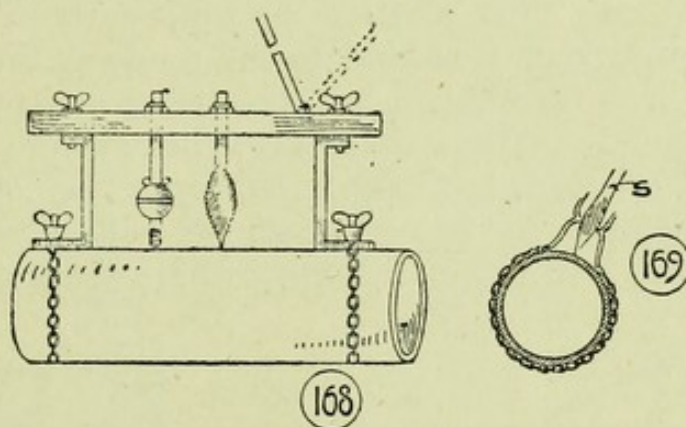

pipe by one chain, tightened up by means of a nut and screw. There is a rubber joint between the machine and the pipe, and there is also a combined drill and tap as in the machine previously described.

The stop-cock is, however, much longer. The machine shown in fig. 168 is used on the top of the pipe, and the service was connected by means of a bent union. This machine is used on the side of the pipe, and the service is connected by means of a straight union. The machine being in position, the drill is passed through the gland shown, the valve is pushed up, the drill held up to the pipe by means of a screw, and rotated by a ratchet. When the hole is drilled and tapped, the drill is withdrawn, the valve in the machine falls against the rubber seating, and the pressure of water behind it renders the valve watertight.

The stop-cock S, the stem of which must be of the same diameter as the stem of the drill, is pushed through the gland and forces the valve open, and is then screwed into the hole in the main which has already been tapped.

The machine is then taken off by disconnecting the two halves.

Fig. 170 is a sectional plan of a "stop and waste" with the communication open. Fig. 171 is the same with the

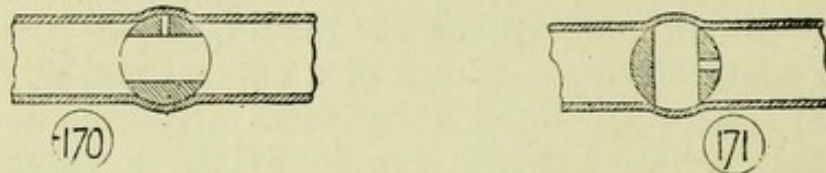

water shut off, and the pipes, at the side on which there is no pressure, are thus allowed to empty themselves. By using a stop-cock of this kind in the roadway the water can be shut off from the house, and the rising main thereto can thus be emptied. Where these stop-cocks are fixed and the water shut off during frost, burst pipes are obviated on account of the water being drawn off. Besides the stop-cocks screwed into the main pipe—where tapping machines

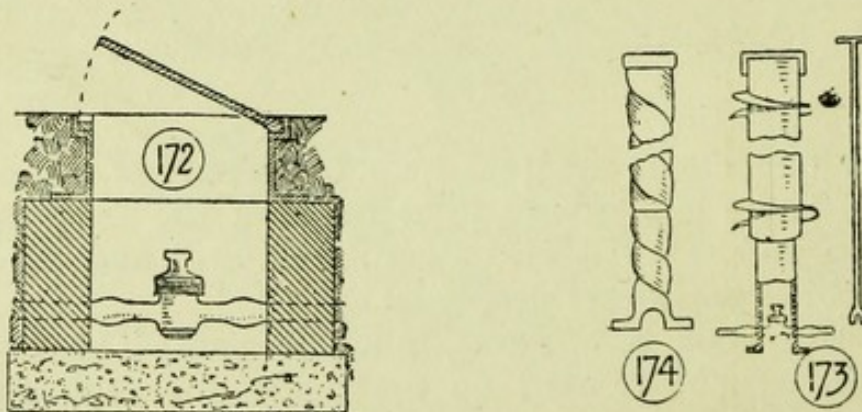

are used—there is usually a stop-cock in the road or garden under the control of the water company or corporation. Fig. 172 shows the ordinary method of gaining access to the shutting-off stop-cock in a road. A dry brick well is built to within about 6 in. of the surface, and a strong cast-iron box with hinged lid is bedded in the roadway.

Figs. 173 and 174 are cast-iron telescopic tubes provided with flanges at each side of the arch over the pipe. The

lowest part is fixed, and the earth is filled in around it. Fig. 173 has two screws on the outside of the upper tube. When the earth is filled in up to the blades of the screws a turn of the tube one way or the other will raise or lower the upper tube. The two tubes in fig. 174 are cast in a special spiral form. The upper is being passed over the lower, and it can be turned until it is screwed down to the required height.

In fig. 173 the stop-cock, under the key, has a flange threaded on the outside to screw into a 2-in. barrel union, a piece of barrel of the requisite length is screwed on, and a cap on the top keeps out the dirt and affords means of access.

2. **Underground Cisterns.**—Fig. 175 is a section of

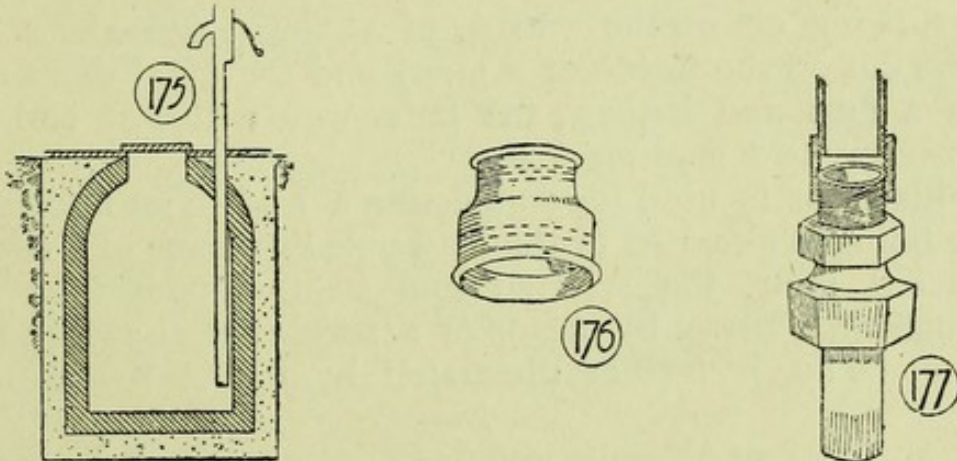

an underground cistern, circular in plan, and bottle-shaped in section; it is built of brickwork with puddled clay backing, and is covered with a stone top, and it is also fitted with a pump. The suction pipe of the pump should reach to within about 6 in. from the bottom of the cistern, so as to prevent the raising of the sediments up the pipe. The suction pipe should be made of iron, as the water in the case of lead may dissolve the metal in the pipe. Water stored in these cisterns is found to be colder in summer and warmer in winter than that supplied through ordinary town mains. It should be cleansed at least once a year. The access to the cistern is by means of a ladder from the top.

3. **Unions and Junctions.**—Fig. 176 represents an

india-rubber closet joint for connecting the closet end of the flushing pipe with the fitting. This is accomplished by tightly binding round the two ends of the rubber cone with copper wire, as shown by the dotted lines. This is illustrated *in situ* in fig. 197, which shows a similar connection of the supply pipe to a lavatory basin.

Fig. 177 illustrates an ordinary barrel union with one end formed with a male screw for iron pipe (*note*: a **male**

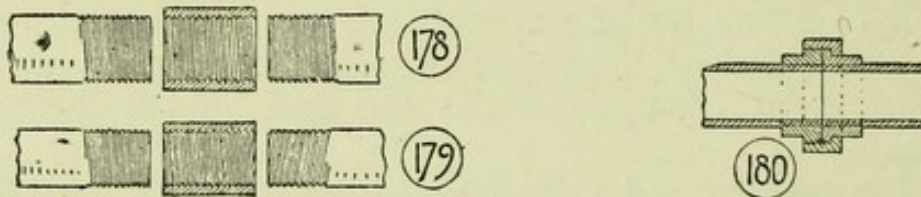

screw is one cut on the outside of a pipe, a **female** screw is one cut on the inside of a pipe) and the other end fitted with a **cap** and **lining**, the latter with a turned end for connecting to a lead pipe.

This joint is used for connecting a lead to an iron pipe. The lining is attached to the lead pipe by means of a wiped soldered joint, the screwed end being attached to the wrought-iron barrel by means of a socket, as shown in this figure. This is further illustrated by figs. 178 and 179.

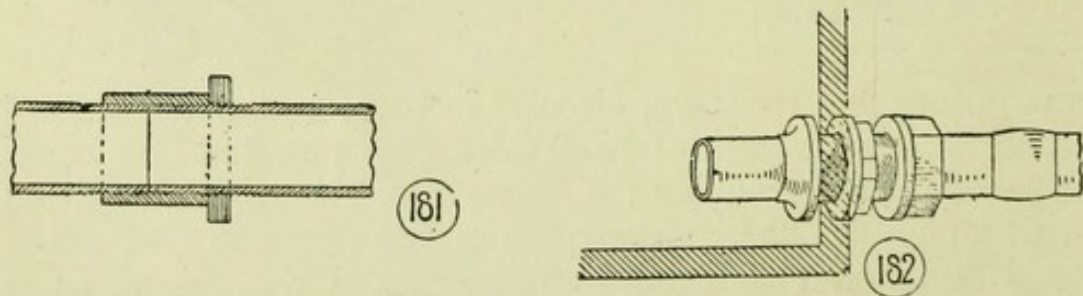

The latter demonstrates the use of right and left-hand sockets.

Fig. 180 shows a barrel union for joining two iron pipes. It will be observed that this method obviates the necessity of using left-hand dies and taps for cutting the male and female threads.

Fig. 181 shows a "connector" joint, and is much used in hot-water work. The back nut is screwed on the end of

a previously cut long thread, and the socket is then screwed on. The pipe to be connected is then placed in position and the socket is then screwed over it (as shown by dotted lines). The back is then screwed close up to the end of the socket very tightly with a packing of red lead and hemp between, so as to prevent leakage.

Fig. 182 shows a boiler screw with **cap** and **lining**. The dotted lines show the outline of a cistern. It will be seen that the fly nut secures the fitting to the cistern. The cap secures the lining to the boiler screw, and the lead pipe is connected to the lining by means of the ordinary wiped solder joint. Inside the cap a leather washer is always used in order to form a perfect joint between the ends of the lining and the boiler screws.

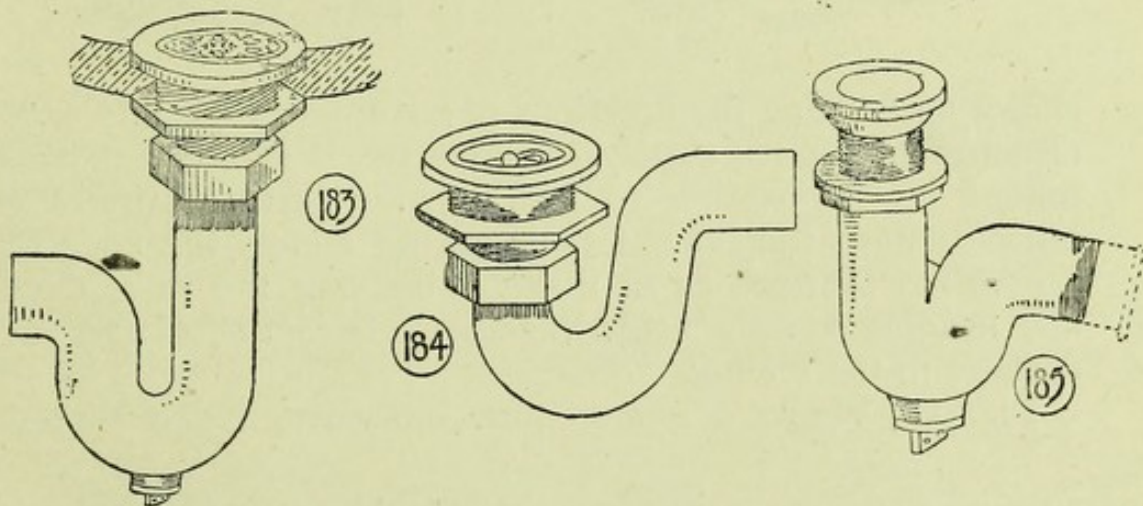

Fig. 183 illustrates the junction of a waste to a bath. It will be seen that this junction is similar in principle to that last described, the hatched portion representing the thickness of the bath.

Fig. 184 represents another form of bath waste, which will be readily understood, the only difference being that plug is substituted instead of a valve.

Fig. 185 shows a similar fitting for a basin, &c. The dotted lines illustrate how this may be varied, so as to have a head at the extremity of the outlet, which will enable the fillet to be caulked to a cast-iron pipe.

4. **Taps and Fittings.**—The idiosyncrasies of the various water companies render the fittings allowed by them

to be varied according to their officials; so that fittings which are permissible and are even recommended in some districts are quite prohibited in others. Sanitary fittings have been previously described. Fig. 166 shows the fitting of a stop-cock for lead pipes, and fig. 167 shows a section of Lord Kelvin's patent bib-tap, which explains itself.

Fig. 186 shows an ordinary screw-down valve, which is

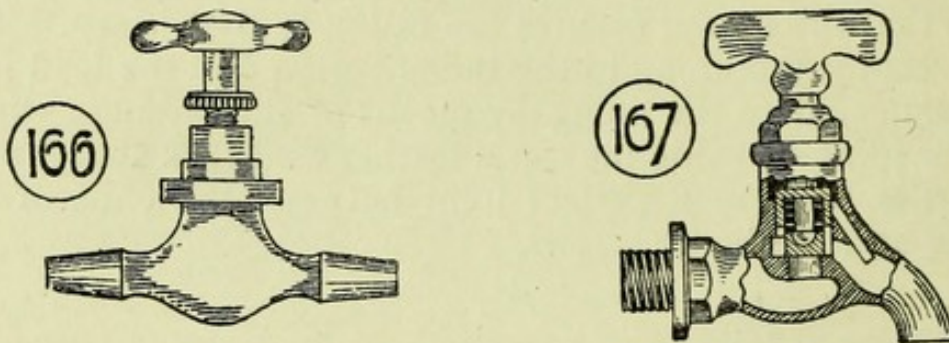

shown performing the functions of a stop-cock so as to shut off and regulate the supply. This valve is shown with two unions for connection to lead pipe. This constitutes a much better arrangement than having merely the ends of the valves **tinned**, as in making the joint the valve does not become unduly heated, and obviates the danger of damage to the sealing.

Fig. 187 shows a quarter-turn bib-valve, which should

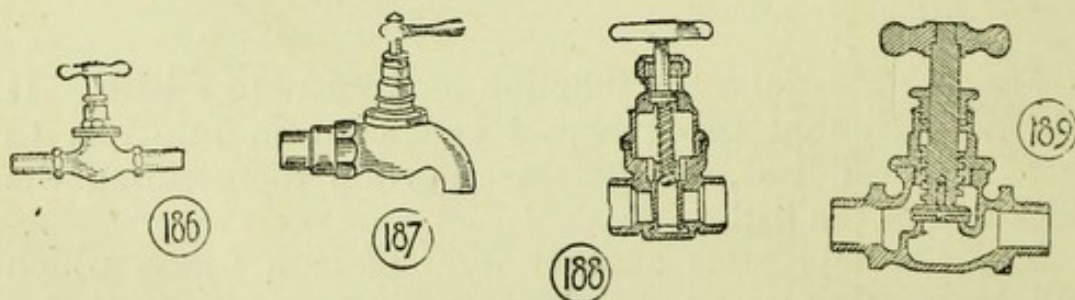

only be used on a low-pressure system, as otherwise the pressure of the water would tend to open the valve.

Fig. 188 represents a section of a clear-way wheel valve, which is useful in connecting fittings where the pressure is low and it is desirable that the valve should not check the force of the supply. Fig. 189 is a section of a quick-turn full-way valve, the full-way being obtained by the extra

sectional area of the body of the tap. Fig. 190 shows a spring valve, which is sometimes used for lavatory basins, where the supply of water is limited and it is desired that no waste shall take place. Fig. 191 shows a bath fitting with a mixing box and thermometer, and is useful in obtaining water at any required heat.

Figs. 192 and 193 illustrate two public bath valves,

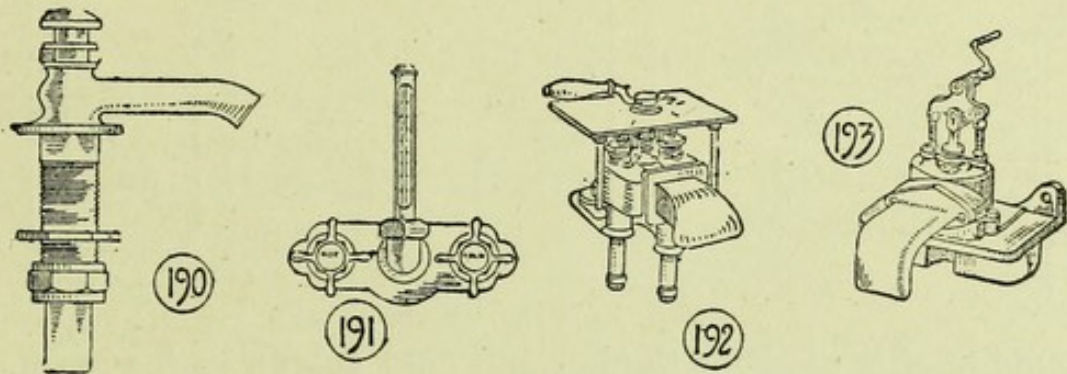

which are used for the purpose of regulating the supply and temperature of the water to the users of the bath by the attendant outside the bath-rooms. Fig. 194 gives a sectional view of a **Fuller Bib-tap**, which is much used on the American continent. The action is extremely simple; by a half turn of the lever the spindle forces the rubber ball up the supply pipe, and the water is immediately released

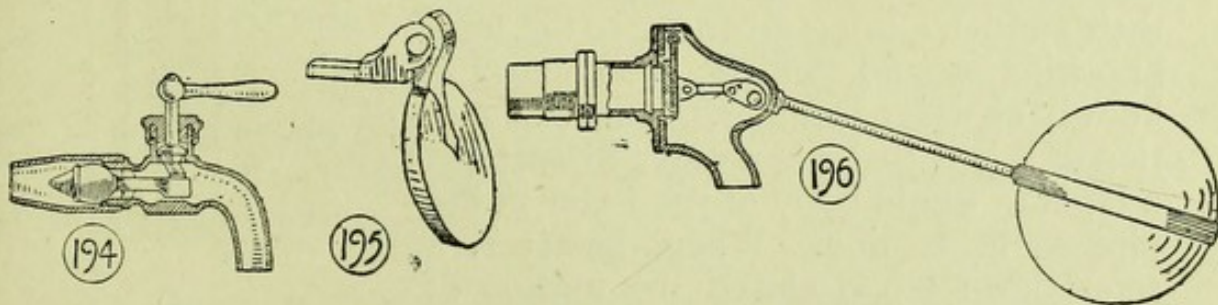

through the tap. It will be seen that when closed the pressure of the water helps to keep the tap watertight.

Fig. 195 represents an ordinary flap valve, mostly used for the ends of overflow pipes, in order to prevent the ingress of birds and dirt, &c. It is also useful in preventing cold weather affecting the ball valve.

Fig. 196 represents a patent full-way ball valve by Messrs. J. Tylor & Sons, and is to be recommended, owing to its

simplicity and to the fact that it acts directly, and a full supply is obtained and would be particularly valuable where only a low pressure is obtainable.

Fig. 197 shows the fittings and connections to a lavatory-basin in which the taps are placed on either side and the

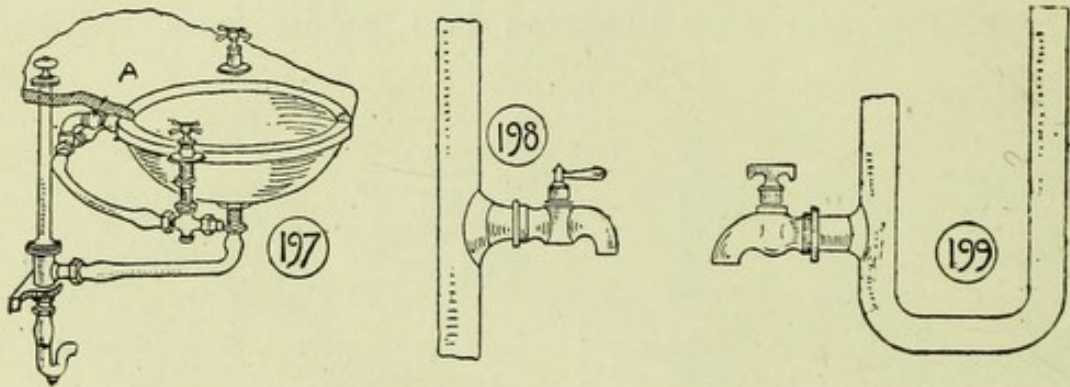

same inlet is used for the hot and cold supply to the basin, which is connected to a flushing rim. This causes the basin to be self-cleansing, which is an advantage; the waste should be carried to the outside of the wall direct and fitted with one of the flap-valves previously described.

Whenever a **Fuller Bib-tap** or a spring self-closing tap is used, they should always be fixed with an air chamber. If these taps are used without air chambers their sudden closing gives rise to the loud knocking sound which is technically known as water hammer. The explanation of this is that when water issues from a tap the whole body of the water in the pipe is in motion. When, however, a screw-down tap is closed the motion of the water is gradually arrested. In the former instances, therefore, the sudden arrest of the motion causes a jarring in the pipe unless air chambers are fixed. When this is done the air in the chamber is compressed and acts as a buffer.

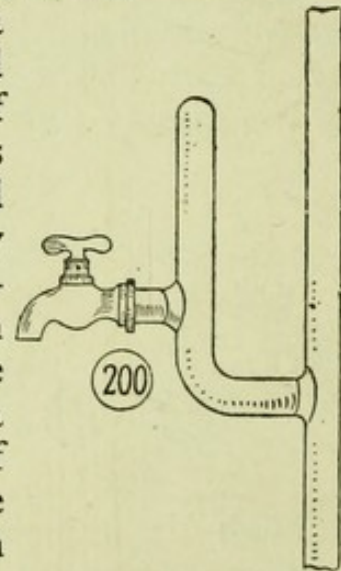

Fig. 198 shows an air chamber when the tap is on an ascending pipe, fig. 199 when the tap is on a descending pipe, and fig. 200 when the tap is on a rising main or on a pipe which also supplies a higher fixture.

CHAPTER XIII.

VENTILATION.

1. *General: Movement of Air and Air Currents.*
2. *Composition of Air.*
3. *Impurities in Air.*
4. *Respiration and Combustion.*
5. *Quantity of Air Required and its Measurement. Cubic Space. Quantity per Person per Hour. Velocity.*
6. *Inlets: Position and Size.*
7. *Outlets: Position and Size. Extracting Power of Flues.*
8. *Natural Ventilation.*
9. *Artificial Ventilation.*

IN this chapter the important questions of ventilation, lighting, and heating are introduced by some preliminary remarks on ventilation.

The three subjects are so interwoven that it is difficult, and perhaps impossible, to think about or discuss them apart; we shall, therefore, in the first place confine ourselves to the composition and movement of air currents, after which we shall proceed to deal with the remainder of these important subjects, and then give actual examples of executed works.

I. GENERAL.

The necessity for ventilation need not be here discussed, as everyone knows that a supply of fresh air is necessary for all human beings. The want of fresh air, properly introduced into a building, produces nausea, headache, and a sense of oppression, sleepiness, lassitude, loss of appetite, and, as a rule, inability to fix the attention. In healthy places of worship there should be no sleepers among the congregation. Anybody can realise some or most of these conditions, as they are felt often after having been in a

stuffy theatre, church, or place of public meeting, and the effects are often intensified next morning. The principal point in all ventilation is to prevent stagnation of air.

Heat—pure heat—has practically nothing to do with the matter, although people are in the habit of referring to a building as being “too hot,” whereas they really mean it is badly ventilated, the excess of carbonic acid having rendered the air impure.

A Turkish bath, although raised to a much higher temperature, has no bad results if properly ventilated; so that pure heat alone has nothing to do with bad ventilation.

Dr. Angus Smith's experiments in a leaden air-tight chamber are interesting in this respect as showing that although the air in rooms may be bad enough to put out candles and paraffin lamps, yet people may breathe it and endure it at the time, although they feel the bad effects afterwards.

A general knowledge of the **Movement of Air** may here be given, because it is on a misconception of the laws which govern movements of air that so many ventilation schemes are failures.

The forces tending to move the air in a room are the wind and the difference in temperature between the outside and the inside of the building. This is to say, that provided sufficient inlets and outlets are furnished the movement of air will be directly proportional to the force of the wind and the difference in temperature, which latter is, by-the-by, the principal agent in natural ventilation.

The wind is, therefore, a strong factor, but unfortunately it acts principally in cold weather, when to open windows or ventilators without warming the air causes unbearable draughts. In warm weather with a warm breeze good ventilation may be obtained, but on a still day in hot weather, with stagnant air, when its frequent change is required, ventilation is wanting. Wind is, moreover, such an uncertain agent that it is not advisable to make any ventilation scheme depend upon it. Natural principles of great importance are: that the specific gravity of cold air is greater than that of hot air, and that air when heated expands and rises. Air expands $\cdot 002$, or $\frac{1}{500}$ of its bulk,

for every degree Fahrenheit it is heated, so that if the air be heated 50 degrees above the external air it will be increased in bulk $\frac{1}{10}$ th, and is, therefore, lighter in proportion. Cold air when introduced into an apartment has a natural tendency to fall, unless properly warmed. As we shall show, this must be done if a ventilation scheme is to be of any use, otherwise in cold weather the inlets are soon closed because of the draught brought about by the introduction of the cold air, because cold air being heavier than hot air a cold draught **descends** from what should be the **outlet** above. This outlet, as a rule, is closed in consequence, and so it is that schemes of ventilation depending on natural forces alone are doomed to failure. Air must be efficiently warmed in this climate for at least six months in the year.

Retracing our thoughts for a moment: when cold air is introduced, it presses against the warmer air of the apartment and causes it to rise in the same way as water, when poured into a glass containing oil, causes the latter to rise to the top.

Next we come to an important consideration, viz., the **velocity** with which air moves. This depends on the difference in temperature between the internal and external air, and increases directly as the height of the extract flue.

It must, therefore, be remembered that any flue extracts a much larger amount in winter; unless we know this velocity we cannot calculate for the required change of air.

Air is best extracted by something in the nature of a chimney or vertical shaft, which, in order to induce a current, should be heated. Extraction is also aided by the effect of the wind which blows across the top and gives a suction power to the shaft. Extraction flues should be as straight as possible, in order to prevent retardation by friction. A horizontal outlet often acts as an inlet, as such an opening will only extract when the wind blows on the opposite side of a building.

It has been calculated that a right angle bend detracts from the carrying power of any tube about 25 per cent., and it may, therefore, be laid down that ventilation tubes should be large, free from bends, smooth, and vertical. The

deduction from velocity caused by friction must always be allowed for. The position of inlet and outlet has much to do with the movement of air currents. Some authorities consider that in winter time it is better to remove air near the floor level, if it is admitted warmed, as it diffuses and pervades the room more thoroughly. In summer, however, when the air is admitted in a cool state, it should be extracted at the top, otherwise it would fall towards the outlet without being distributed. This is the plan adopted in German schools.

2. Composition of Air.

Air consists mainly of oxygen and nitrogen in the following proportions by volume:—Oxygen, 21 per cent.; and nitrogen, 79 per cent.; and in addition there is always present a small proportion of carbonic acid gas, and often one or more of the following, viz., ammonia, ozone, or water vapour, argon, &c. In addition, suspended solid matter of mineral or organic particles; and microbes are found under unfavourable conditions. According to Dr. Angus Smith, the purest sea or mountain air contains as much as 20·999 volumes per cent. of oxygen (or nearly 21, as stated above), but the worst air found in a mine contained only 18·27 per cent. In the air of towns the average limit is about 20·96 per cent., and in overcrowded halls the percentage may be as low as 20·65, so that the percentage must be kept within comparatively narrow limits. The amount of oxygen may be decreased in a variety of ways, such as combustion (gas, fires, candles, lamps), by respiration, by fog, organic effluvia, &c.; on the other hand, it is increased by vegetation and by rain.

Ozone is a condensed form of oxygen, having a beneficial influence on the health. It is principally present near the sea and open country, and is rapidly destroyed by smoke and other impurities.

Oxygen we must have continually, as on it depend the maintenance of our bodily heat and of energy.

In town houses, in order to prevent impurities such as particles of soot and dust entering, air should be screened by causing it to pass through cotton wool or water. This

may be effected by a filtering medium placed diagonally in a tube and presenting a surface about eight times the area of the inlet. This filtering medium should, of course, be changed frequently.

3. THE PRINCIPAL **Impurities** FOUND IN AIR ARE :—

- a. Carbonic Acid Gas (CO_2).*
- b. Carbonic Oxide (CO).*
- c. Sulphuretted Hydrogen.*
- d. Marsh Gas.*
- e. Ammonia Compounds.*
- f. Suspended Matters of all Kinds.*

a. Carbonic Acid (CO_2) is generally taken as the gauge of impurities in air, as it is generally present in excess of other impurities.

It emanates from underground sources in the form of gas, or in solution in mineral waters, also from respiratory processes of animal life. It is increased by combustion, putrefaction, fermentation, and fog. It is diminished by vegetation, rain, and high winds. In designing a system of ventilation it is necessary to provide a sufficient change of air to keep the amount of carbonic acid below a certain percentage, as its presence and the consequent exclusion of oxygen tends to prevent the possibility of animal life.

The quantities in which this gas is found in the atmosphere vary from 0.3 parts per thousand in the finest mountain or sea air, to 1.0, 2.0, or even 3.0 in overcrowded rooms. The average proportion in the open air is about 0.4 per thousand.

The late Sir Douglas Galton stated that 1.5 parts **per cent.** produce nausea, depression, and headache; 2.5 per cent. extinguishes a candle; 5 parts per cent. is fatal. The greatest amount of carbonic acid gas which may be present in air without harm is generally taken at .6 per thousand cubic feet.

b. Carbonic Oxide (CO) is formed by the imperfect combustion of carbon, and cast-iron stoves give it off in considerable quantities. Air containing 0.5 per cent., according to Galton, produces poisonous symptoms.

c. **Sulphuretted Hydrogen** is formed in the air of sewers, in excavations, in marshes, and near gasworks, &c.

d. **Marsh gas** is found in the air of marshes and also of coal mines, where the proportion may be sufficient to destroy life by the exclusion of oxygen. **Malaria** appears to arise from decaying moist vegetable matter in forests and marshes.

e. **Ammonia** compounds are derived principally from putrefaction and animal exhalations, and are injurious from the impurities which accompany them.

f. **Suspended matters are of all kinds**, such as dust formed of mineral articles, or organic matter of animal or vegetable origin. Stonemasons suffer from inhaling stone dust, house-painters from the dust of white lead; and the dust of the Egyptian desert produces a kind of ophthalmia. Bronchitis and lung disease occur in factories by inhalations of sand, coal, &c., or particles of cotton or hemp. Indeed, it may be said generally that the air of towns is rendered impure chiefly from the quantity of suspended matters in the air.

4. Respiration and Combustion, &c.

Respiration.—Beside the ordinary impurities, the action of breathing or respiration helps to render the air in a room impure unless it is renewed. Respiration abstracts oxygen, increases carbonic acid, and adds watery vapour, ammonia, and organic matter to the air; besides which there are exhalations more or less odorous from the skin. The amount of carbonic acid given off by an adult per hour is .6 cubic feet.

Combustion.—Coal when burnt gives off carbonic acid, carbonic oxide, sulphuric acid, and other impurities. According to Galton, analyses of various sorts of coal showed that they contained a mean of 1.7 per cent. of sulphur, and that the ash from such coal contained only 0.2 per cent. From this it will be seen that the burning of 1,000 tons of coal would send fifteen tons of sulphurous acid into the air, which would become converted into sulphuric acid.

Turning to coal gas we find that it forms an important

cause of impurity in houses, for its products of combustion are carbonic acid, carbonic oxide, ammonia, and sulphur compounds.

Without going fully into calculations it is stated that each cubic foot of gas burnt per hour vitiates as much as one human being does by respiration. An oil lamp similarly affects the purity of the air, but in a less degree, although for the amount of light obtained it is stated to foul the air more than gas.

5. Quantity of Air Required.

We have now considered the composition of air, the impurities to which it is liable by contamination, and also by respiration and combustion. We now come to the very important point as to the quantity of air required by a human being.

According to Hood, women and children do not require such a large allowance as men, the proportion being two-thirds for females, and one-half for children.

Respirated air contains about 4.5 per cent. of carbonic acid, depriving the air of that amount of oxygen. An average adult, as already stated, gives off about .6 cubic feet of carbonic acid per hour, and as 1,000 cubic feet of air under average circumstances contain .4 cubic feet of carbonic acid, an addition of .2 cubic feet will reach the limit of the standard of purity allowed, viz., .6. An adult will therefore render 3,000 cubic feet of air impure in one hour, because he will add .2 cubic feet to each thousand, which will thus have absorbed the largest amount of carbonic acid which is permissible.

We now, therefore, arrive at the following data, that we should have a system of ventilation which shall give each person 3,000 cubic feet of fresh air per hour. Thus in an air-tight room or compartment, for a man to live, say, ten hours, it would be necessary for it to contain 30,000 cubic feet, if the air was not to be rendered more impure than the accepted standard. If an airtight room only contained 1,000 cubic feet, it would, by the same calculation, suffice for one person only twenty minutes.

This is a Utopian standard, however, which in practice seems to be seldom adhered to, and, indeed, Hood takes pains to state that it may not be necessary. The late Sir Douglas Galton asserted that no room could be considered even tolerably ventilated as a permanent arrangement unless at least 1,000 cubic feet of air per occupant are renewed per hour. Consequently, in a room 20 ft. by 15 ft. by 10 ft. high, which contains 3,000 cubic feet, and is occupied by three people, the air would not require changing more than once an hour, but if occupied by fifteen people, it would require renewing five times an hour.

Authorities differ largely as to the quantity of air required. Dr. Whitelegge, for instance, states that 500 cubic feet per hour is the minimum allowance, and that for rooms not continuously occupied 1,000 ft. per head is quite sufficient if passing through the room at a velocity not exceeding 5 ft. per second. Other writers give from 3 to 30 cubic feet per minute for people undergoing no exertion, and as much as 70 ft. for ball-rooms, hospitals, or workshops.

As it is generally practically impossible, however, to tell the number of people who will inhabit any particular apartment, heating engineers as a rule, calculate that the air of an apartment should be changed from one to six times an hour according to the purposes for which it is used, *e.g.* :—

	Times an hour.			
Large hall and churches (in consequence of large cubic space)	1
Dancing-rooms	4
School-rooms	3
Hospital	5 or 6

Rooms are rarely so well built but that air can enter freely. The doors and windows of ordinary houses are not so closely fitted as to prevent air currents, which thus ventilate the room, even in the absence of other intended ventilation.

Again, sitting-rooms are not used continually like hospitals, and will, therefore, get their supply replenished in the intervals.

In order, however, to avoid draughts, it is usually assumed,

in a country like England, that the air of a compartment should not be changed oftener than three times an hour, unless the incoming air is warmed; so that a room containing 1,000 cubic feet, which could be changed as above, is generally stated as a standard of measurement for ordinary purposes.

This question of draughts is most important, because no system of ventilation can be considered perfect which produces such a draught as can be felt by the inmates.

Further, the supply of fresh air should not move with a greater velocity than 5 ft. per second, so that the number of people in an apartment should be regulated in such a way that sufficient air can be given at a velocity not exceeding that rate.

Cubic Space.—As to the amount of *cubic space* which should be provided for each person, the following table has been prepared after reference to various other authorities:—

	Cubic feet of space per head.
London Board School	130
Board Schools (Education Dept.) ...	80
Canal Boats (adults)	60
" (children)	40
Common Lodging Houses	300-400
Army Permanent Barracks	600
Prisons with separate cells	800
	per bed.
Army Hospital Wards	1,200
	per seat.
Army Chapel Schools	200
" Infant Schools	96
	per horse.
Stables (open roofed)	1,200
" (with men over)	1,300

Quantity of Air per Person per Hour.—The following table from Hood gives the quantity of air which

should be provided *per person per hour* for a room occupied to its maximum capacity, the inlet being sufficient:—

	Cubic feet per person per hour.
Ordinary living rooms	1,200
Sleeping apartments	900
Schools (scholars of full age)	900—1,200
„ (infants)... ..	720
„ (dormitories)	720
Meeting rooms, public halls, lec- ture rooms	1,200—1,500
Ball rooms	2,100—2,400
Theatres, dining halls, &c.	1,200—1,500
Hospitals (ordinary)	1,200
„ (infectious)	2,100—3,000

It will be seen from this table that Hood's standard is not as high as many authorities, but in practice it seems to be the one most usually adopted. In very many cases it is even considerably higher than that which is obtained.

As an example, by the Factory Acts adequate ventilation is prescribed, and this is generally taken as signifying 250 cubic ft. per head per hour in ordinary working hours, and 400 cubic ft. during overtime.

From these data the amount of air which it is necessary to introduce per hour can be calculated to maintain a given standard of purity.

Let x = volume of fresh air required per hour per head to maintain required standard B.

A = the number of cubic feet of carbonic acid in 1,000 cubic feet of fresh air = 0.4.

B = proposed maximum limit of carbonic acid in the air of a room (usually taken at 0.6 parts of carbonic acid per 1,000 volumes of air).

C = the number of cubic feet of carbonic acid given off per head per hour = 0.6.

n = number of persons to be provided for.

$$\text{Then } x = \frac{C \times n}{B - A} \times 1,000 = \frac{600 n}{B - 0.4} = \frac{600 n}{0.6 - 0.4}$$

And supposing that the number of persons = 100, then

$$\frac{600 \times 100}{0.6 - 0.4} = \frac{60,000}{0.2} = 300,000 \text{ cubic feet per hour.}$$

And provision must be made for this amount to enter, the impure air being extracted at the same time.

Velocity.—According to “Montgolfier’s” rule, air under pressure will enter a **vacuum** with a velocity equal to that acquired by a body falling from a corresponding height (H), and this velocity is determined by the formula $V^2 = 2gH$.

When H = the height (under standard conditions of barometer and thermometer H = 5 miles, or 26,400 ft.).

g = acceleration due to gravity (32.18 ft. per second).

V = velocity required in feet per second.

$$\therefore V^2 = 2 \times 32.18 \times 26,400.$$

$$V^2 = 1,699,104.$$

$$V = 1,300 \text{ ft. per second.}$$

In ventilation problems, however, the air passes not into a vacuum, but into a space containing air at a low pressure, so that the velocity is dependent upon the difference of the barometric pressure (P) and the air under a low pressure (p).

It is also necessary to calculate the height (h) of a uniform column of air of the standard of density (as was adopted in determining H), which would give the pressure ϕ .

The formula being, therefore, for ordinary ventilation problems:—

$$V^2 = 2g(H - h);$$

and after substituting various values it may be put—

$$V = 8 \sqrt{x - \frac{x}{1 + .002(t - T)}}$$

in which x = height of vertical flue.

t = temperature of room.

T = „ „ open air.

Example:— Let $t = 60^{\circ}$ F.
 $T = 40^{\circ}$ F.
 $x = 20$ ft.

$$\text{Then } V = 8 \sqrt{20 - \frac{20}{1 + .002(60 - 40)}}$$

$$V = 7.1 \text{ ft. per second.}$$

Therefore, if we find the sectional area of the flue in feet and multiply by the linear velocity, it will give us the number of feet discharged per second.

There is one point which in practice we must not admit, and that is friction; this varies directly as the length of the tube L and the square of the velocity, and inversely as the diameter D , viz., $\frac{V^2 L}{D}$. In practice this allowance is usually $\frac{1}{4}$.

De Chaumont's rule for ascertaining the relation between the size of the opening and the hourly delivery of air is as follows:—

$$D = 200 \times \phi \times \sqrt{.002 \times x \times (t - T)}$$

where D = the required delivery of air in cubic feet per hour.

ϕ = sectional area of inlet or outlet or of tube in square inches.

x = height of heated column of air in feet.

t and T = internal and external temperatures respectively.

Example:

$$\text{If } x = 20$$

$$t \text{ and } T = 60 \text{ and } 40 \text{ respectively}$$

$$D = 6,000$$

$$\text{Then } 6,000 = 200 \Phi \times \sqrt{.002 \times 20 \times (60 - 40)}$$

$$6,000 = 200 \Phi \times \sqrt{.8}$$

$$6,000 = 178 \Phi$$

$$\frac{6,000}{178} = \Phi$$

$$33 \frac{126}{178} = \Phi$$

$$33.56 = \Phi$$

6.—Inlets.

Their Position and Size.—There is a considerable difference of opinion as to whether the inlets should be at the top of the room or low down, but the best position seems about 6 ft. from the floor level, and if possible on the same side of the room as the fireplace.

Inlets should be so arranged as to draw the air from a pure source. They should be short and accessible, otherwise they collect dirt and vermin, for what is the use of admitting air if before it reaches the apartment it becomes fouled by accumulations of dirt? The air is introduced about 6 ft. from the floor, so as to give the air an upward direction above the heads of occupants. Inlets should be well distributed, so that all parts of the room may

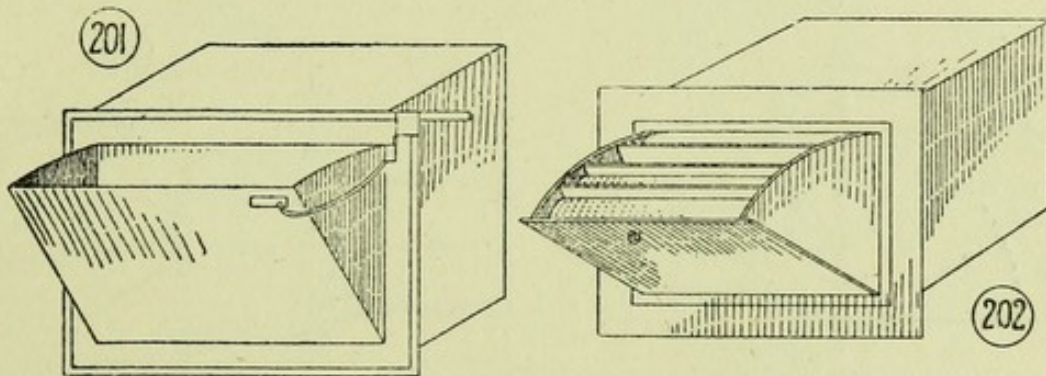

be air cleansed. The incoming air should, of course, be warmed in winter, but in ordinary houses where this is not done the inlets should be distributed so as to diffuse and mix with the air of the room before it reaches the occupants. Inlets should be capable of partial closing.

Air may be introduced through a Sherringham's ventilator (fig. 201), which is much better than an ordinary grating, because it is provided with flaps falling inwards, and with cheeks, so that the air is forced upwards first, and then diffused. The "Harding" diffuser can be placed in its mouth, and this spreads the stream of the air.

Figs. 202 and 203 show respectively a view and section of a very good inlet ventilator patented by Mr. Joseph Leather, of Liverpool. It is on the same principle as the "Sherringham," but is a decided improvement on it. It will be seen

by the section fig. 203 that the cheeks are divided into four compartments, the bottom two being covered with perforated zinc, marked D in the figure.

This is to stop the air from coming into the room in too draughty a course, and tends to drive the air up in a vertical direction through the two upper compartments, and at the same time prevents any dirt or rubbish from getting into the room. The ingress of the air can be regulated by the movement backwards and forwards of the flap.

Figs. 204 and 205 show another example of an inlet ventilator, which is called the "Venetian Louvre Ventilator," and it is also patented by Mr. Joseph Leather.

Fig. 204 shows the ventilator open, and the working arrangement is as follows:—

The centre top and bottom louvres A, B, and C are fixed

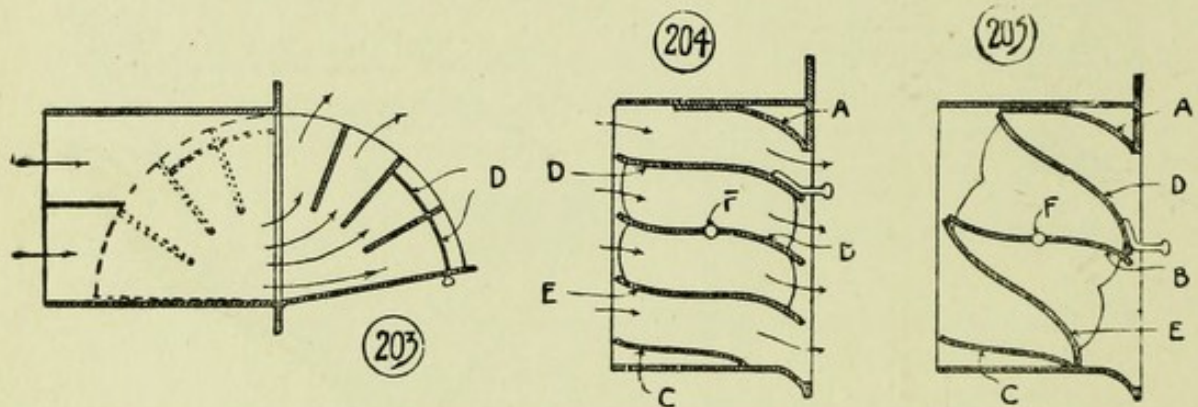

and by pulling the handle down the two louvres D and E (which move in conjunction on a plate fixed to the centre F) are brought on to B and C, as shown in fig. 205, which shows the ventilator closed.

This form can be recommended, and it has the advantage of being arranged in the thickness of the wall, and no flap is visible on the inside of the room when the ventilator is open. Both these forms of ventilators are being extensively used in London and the provinces.

A "Tobins" tube inlet (fig. 206) is an upright tube placed at the side of the room, formed of $1\frac{1}{4}$ in. boarding, and lined with zinc. Its top should be at least 6 ft. from the floor, so as to prevent people feeling a draught. It is provided with a butterfly valve to regulate the admission.

The disadvantage is the long tube, which is difficult to clean. The top is covered with perforated zinc, marked H in the figure.

We cannot condemn too strongly the placing of hot-water pipes below a floor level, covered by gratings; such ducts become the receptacles of all sorts of filth, which dries into dust and is carried about by the air current set up, and contaminates the atmosphere to be breathed.

A form of inlet which should be provided to every room

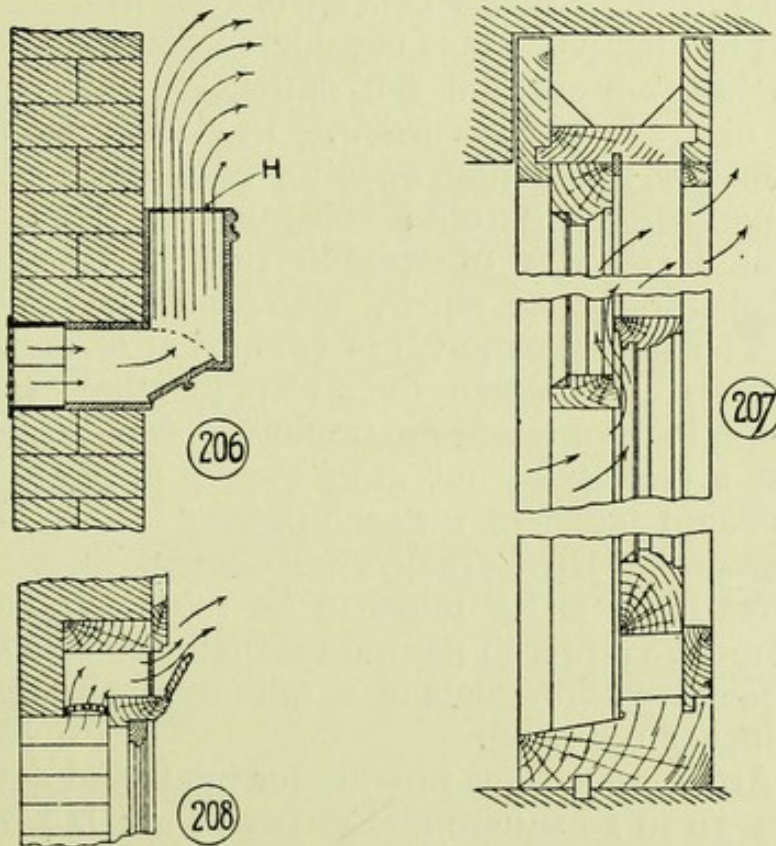

is made by placing a deep bead on the ordinary sash window (as shown in fig. 207), the air being admitted between the meeting rails in a vertical direction. Fig. 208 shows the introduction of fresh air at the head of the window. The supply can be regulated by the soffit lining having a hinged flap.

When the temperature of the outer air is below 45 deg. it is found by experience that inlets get closed unless the air is warmed. This is done by passing it over ventilating radiators, which are illustrated in examples given in another chapter. In smoky towns, the incoming air is often cleansed

by passing it through a screen of cotton wool, or horsehair and fibre, upon which in some cases a sheet of water is poured at short intervals. This screen arrests the impurities, which are washed off by the water.

Size of Inlets.—Dr. Corfield states that 24 square inches is the sectional area which should be allowed as an inlet for each person; so that one square foot is required for six persons. Therefore six air bricks of the effective area of 24 square inches would be sufficient for six persons. Such an allowance seems excessive, and, in fact, is seldom obtained in practice. It is considered advisable to give the inlets a larger area than the outlets, as this reduces the velocity of the inflowing current. In calculating the size of the openings, the actual opening only must be counted, deducting bars and other obstructors, &c. The late Professor Jacob was of opinion that in calculating the size of openings, one square inch of unobstructed space will, as a maximum, admit 125 cubic feet of air per hour; on this basis eight square inches would admit 1,000 cubic feet, which in rooms not continuously occupied and introduced at a velocity of not more than 5 ft. per second may be considered sufficient for each person. This, however, is just one-third of Dr. Corfield's calculation.

The tendency is for inlets to be too small, considering the low motive power in natural ventilation. The Education Department require inlets of a minimum allowance of $2\frac{1}{2}$ square inches per child.

The Army regulations provide for inlets and outlets varying from 10 to 20 square inches per head; but in all cases the ratio of inlets and outlets to cubic space are as 1 is to 60.

Hood's rule.—For ordinary rooms provided with a good fireplace, Hood propounded a practical rule based on experience, taking into account the size of the room, the number of occupants, and the gas burners, &c. :—

Size of Room.		Number of Occupants.	Number of Gas Burners.		Net Size of Ventilator.	
ft.	ft.				in.	in.
10	by 10	... 2 or 3	... 2	...	9	by 3
16	by 12	... 3 or 4	... 3	...	9	by 6
20	by 16	... 4 or 5	... 4	...	9	by 9

Figs. 209 and 210 show a view and section of Ellison's air inlets. The principle used is to make cone-shaped holes with the small end situated on the exterior, so as to prevent any draught.

Fig. 214 shows an inlet by Messrs. Doulton. It is of earthenware, and 4 in. in diameter. The top is fixed with a hinged flap, which can be regulated as desired.

7. Ventilation Outlets.

Their Position and Size.—The position of an outlet depends on the inlet. In a general way, it should be removed as far as possible from it. The natural outlet of a

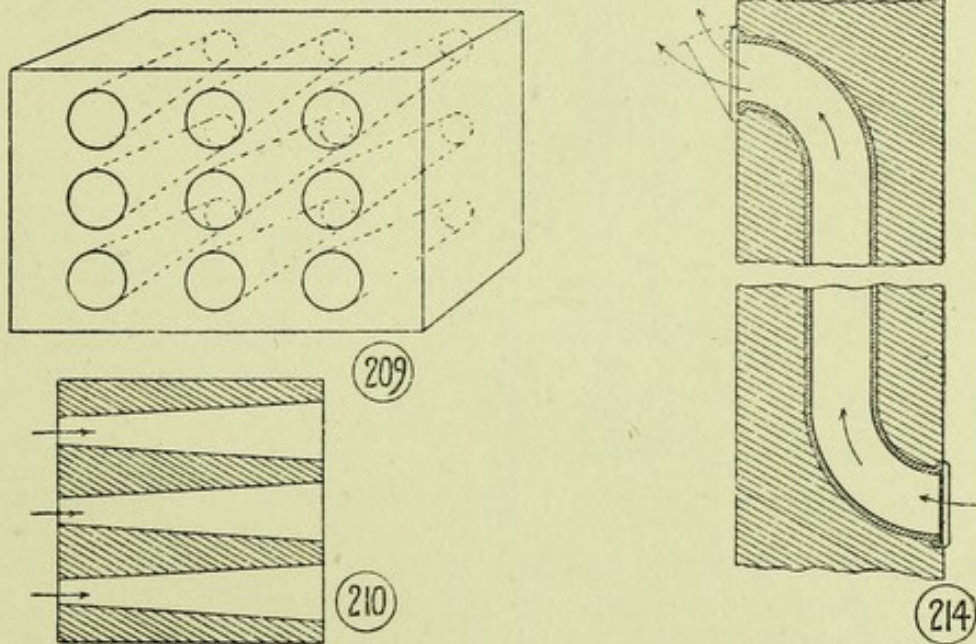

room is the fireplace, where there is (or should be) always an up current. The fireplace, however, draws the air out of the bottom of the room, computed at an average velocity of 4 ft. or 5 ft. per second, and we cannot get away from this factor in ventilation which is provided for us in every room. This factor induces many authorities to suggest "downward" ventilation, the foul air being drawn out at the bottom of the room. The air currents in a room with an ordinary fireplace are shown in fig. 211. As has been pointed out, in an ordinary room with closed doors and windows the air is drawn along the floor to the fire, part goes up the chimney

to help the process of combustion, part, in consequence of its warmth and impetus, flows towards the ceiling. As it cools in traversing the ceiling towards the opposite wall it descends until again warmed. It follows, therefore, that in order to equalise the temperature of the room, the best place to introduce air is in the chimney breast wall above the mantelpiece.

The amount of air that a fire requires is large, and where no heating system is in use quantities of cold air are drawn in to supply this need through cracks of doors and windows to such an amount that draughts are the result. Although

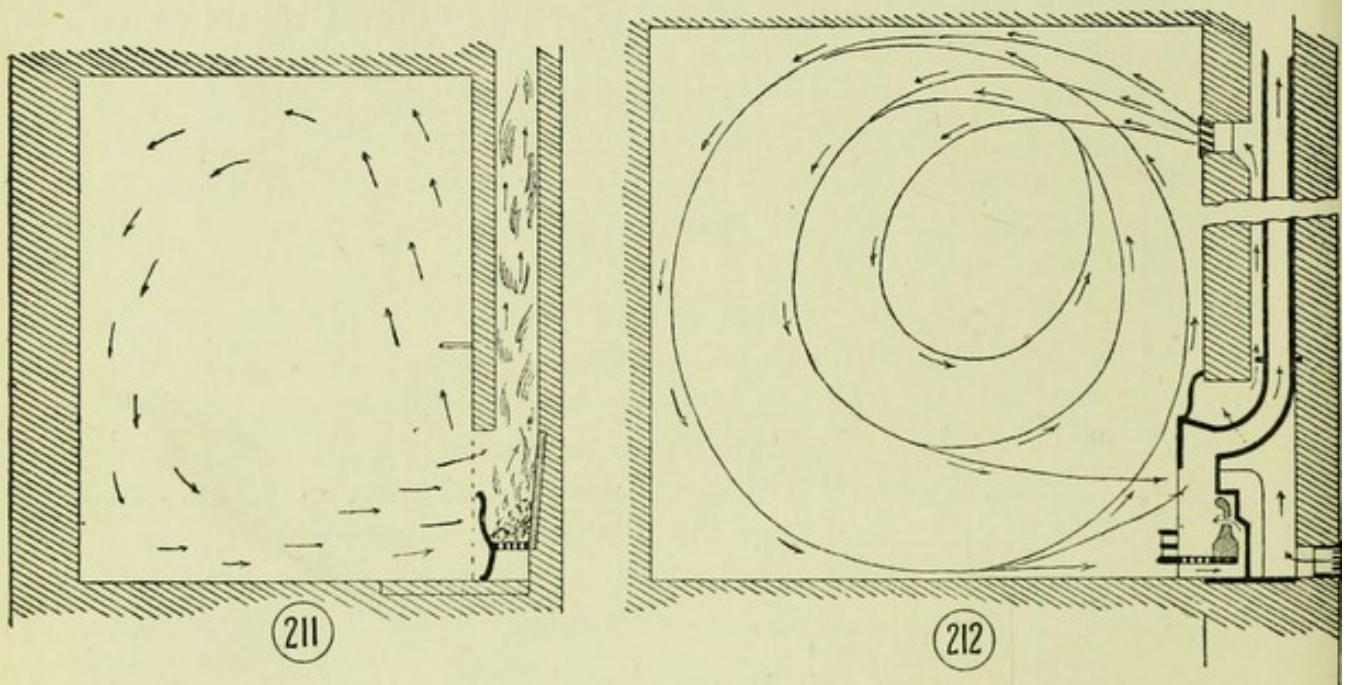

rather trenching on the subject of heating, yet it may be as well to mention here that although cold air may be introduced above the chimney mantel, warmed fresh air can also be introduced there by means of Galton's ventilating grate (fig. 212), in which the air is introduced in a separate flue and passed round a heating surface before entering the room. Such air-tubes, however, require constant cleansing.

Even when air is not introduced to the room it is often advisable to supply fresh air to the fireplace itself in order to aid combustion without drawing cold air from the cracks in doors and windows. The Education Department require an air flue of 72 square in. to each fireplace.

Besides the fireplace opening, outlets may be formed into the smoke flue near the ceiling level. Fig. 213 shows a "mica flap" outlet, which is generally employed in such a situation to prevent a back draught. Thin sheets of mica are hinged on to a frame from the top, and so arranged that the slightest pressure from the flue closes the outlet, and so prevents the entry of smoke into the room. On the other hand, foul air readily escapes. The noise made by the mica flaps, however, is very irritating.

If it is desired, however, to extract air from the top of the room, it is better to have a separate foul air flue, which costs little in a new building. This is warmed by being close to the smoke flue, and consequently has a steady up-current.

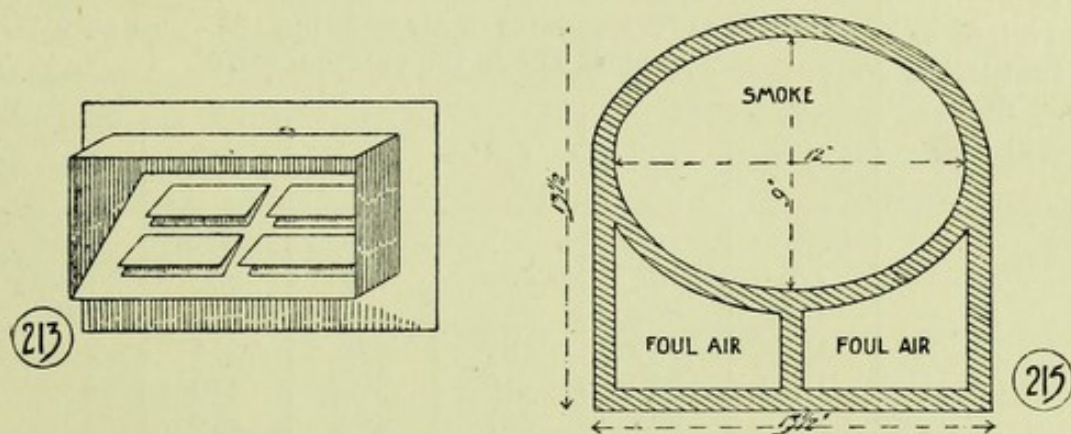

Another method is by **ventilating flue pipes**, as shown in fig. 215. These are made by Messrs. Doulton in conjunction with flue pipes (which are used instead of the ordinary "parged and cored" flue). They are made of different sizes and shapes, with either one or two air flues as desired. One outlet is, as a rule, considered more efficient than several. The size of outlets and extracting power of flues have been dealt with.

The Education Department require outlets equal to at least two square inches per child, leading into a separate air chimney carried up in the same stack as the smoke flues.

One maxim to remember is that an outlet must have motive power by heat or exhaust, otherwise it will frequently act as a cold inlet.

Extracting Power of Flues.—Hood arrived at some practical results by experiment as to the extracting power of flues, and we cannot do better than give his table. All that is necessary to make the calculations is to know the temperature of the outer air and that in the vitiated air shaft.

It is to be noted that although the quantity of air extracted depends on the height of the shaft, yet it does not increase directly as to its height, which is due to loss of heat by the ascending air and friction.

Table showing the quantity of air extracted per minute by a ventilating shaft whose area is one square foot ; fresh-air inlets being equal in area or a trifle larger :—

Height of ventilating shaft in feet.	Excess of temperature of air entering the ventilating shaft above the external air.					
	5°	10°	15°	20°	25°	30°
10	116	164	200	235	260	284
15	142	202	245	284	318	348
20	164	232	285	330	368	404
25	184	260	318	368	410	450
30	201	284	347	403	450	493
35	218	306	376	436	486	531
40	235	329	403	465	518	570
45	248	348	427	493	551	605
50	260	367	450	518	579	635

As an example, suppose that the height of the shaft is 40 ft., which would be an average height for an ordinary dwelling-house, and the difference in temperature between the outer air and the vitiated air in the shaft be 20 deg., then the discharge would be 465 cubic feet per minute. As the amount of air extracted is greatest in winter, when the difference between the inner and outer air is greatest, the calculation should be made for summer ventilation, and the ventilator may be regulated by mechanical means or by a special form of grating.

8. Natural Ventilation

is that mostly in general use for ordinary buildings, and consists in the removal of foul air and the admittance of fresh by natural means, such as by doors, windows, fire-places, &c.

In natural ventilation the forces relied upon to supply rooms with fresh air are (1) the wind, which, on the calmest day in England, moves at a velocity of one mile per hour ; and (2) the difference in the specific gravity of the inside and outside air.

Nature assists in ventilation, as before explained, because air, when heated, expands and rises, and consequently heated and fouled air given off by the body rises, and can be removed from the apartment by foul-air flues, if fresh air is admitted to take its place. Thus, if cold air is introduced at the lower part of the room and an extract for heated air formed at the top, a natural means of ventilation is provided. Natural ventilation is, however, too much subject to atmospheric conditions to be reliable, and is practically only serviceable in ordinary houses.

9. Artificial Ventilation

includes any system dependent on mechanical means of propulsion and extraction, and may be divided into two systems, viz., the **plenum** and the **vacuum**. In the **plenum** system propulsion is adopted, by which means fresh air is driven into rooms by means of fans or air pumps, and the foul air thus forced to find its way out. This appears to be by far the most satisfactory method. Several examples will be illustrated later on.

The **vacuum** system consists in producing strong up-currents in special extracting shafts by means of either a furnace, gas jets, hot water pipes, or steam coils, steam jets, or by fans, or exhaust pumps worked by steam or electricity. By this means the foul air is drawn out of the room and fresh air is allowed to enter.

From the observations of Carnelly, Haldane, and Anderson, conclusive evidence has been arrived at proving the superiority of artificial over natural ventilation ; as the

following table shows. In this case the buildings experimented on were schools :—

	Natural Ventilation.	Mechanical Ventilation.
Per cent. of windows open	22	3
Cubic feet of air space per head	168	164
Temperature (Fahrenheit)	55.6°	62°
Carbonic acid (per 1,000 volumes)	1.86	1.23
Organic matter (volumes of oxygen required per million volumes of air)	16.2	10.1
Microbes (per litre)	15.2	16.6

The great difficulty in the application of artificial and mechanical ventilation is the cost, and occasionally, the liability to get out of order ; on the other hand, it possesses the great advantage of constancy under every change of atmosphere, and is, or should be, completely under control as to the supply and source of fresh air, its filtering, purification, temperature and humidity.

All public buildings should be heated by mechanical means.

Of the plenum and vacuum systems, the "plenum" is considered by experts to give the best results, because by employing propulsion the air can be cleansed, tempered, and brought to a proper hygrometric condition. This can be ascertained by the hygrometer (which is an instrument for measuring the moisture of the atmosphere), and forced in directions most suitable, whereas by the vacuum or extraction method neither of these purifying agencies is available, and the source of the supply is not under the same control. Moreover, it is now generally admitted that employing the "plenum" and "vacuum" in one scheme is a mistake.

In the examples which will be placed before the student both methods are shown.

CHAPTER XIV.

Heating.

THIS subject may be conveniently dealt with under the following headings :—

- | | |
|--------------------------------|----------------------------------|
| 1. <i>General Remarks.</i> | 6. <i>Hot Air.</i> |
| 2. <i>Open Grates.</i> | 7. <i>Electricity.</i> |
| 3. <i>Close Stoves.</i> | 8. <i>Hot-water Supply.</i> |
| 4. <i>Hot-water Apparatus.</i> | 9. <i>Safety Valves, &c.</i> |
| 5. <i>Steam-pipes.</i> | |

1. General Remarks.

It must be clearly understood that all heating arrangements must be subservient to the scheme of ventilation, and these most important arrangements should be considered together in the designing of any building. Heat may be considered of two kinds, viz., **radiant** and **convexed**; the former is that which is conveyed in straight lines from a heated surface and its intensity (like light) decreases as the square of the distance. **Convexed** heat may be made clear by the following example :—When the air around heated surfaces becomes warmed, the surrounding and colder air forces it upwards; this is constantly repeated till the whole of the air is warmed.

2. Open Grates.

For a small room this is undoubtedly the most cheerful and pleasant method. Modern stoves of the *Pridgin Teale* model are a vast improvement upon the old-fashioned kinds in which nearly all the heat was sent up the flue, only about one-sixth being sent into the room. By looking at figs. 216, 217, and 218, it will be seen that the sides and back being of firebrick, and the latter being well inclined forward, the intensity of the heat is much increased, and is thrown more into the room than in the other grates. The movable

ashpan regulates the draught, so that more perfect combustion can be obtained and the removal of the ashes is facilitated. In addition to the above the "throat" of the flue should be contracted and the front and bottom bars should be narrow. In this same figure it will be noticed that a supply of fresh **warmed** air can be obtained by means of an inlet flue which is warmed by the fire. There are very many patent grates now in the market involving the above principles in various modified forms. It is well to remember, however, the danger of more complicated

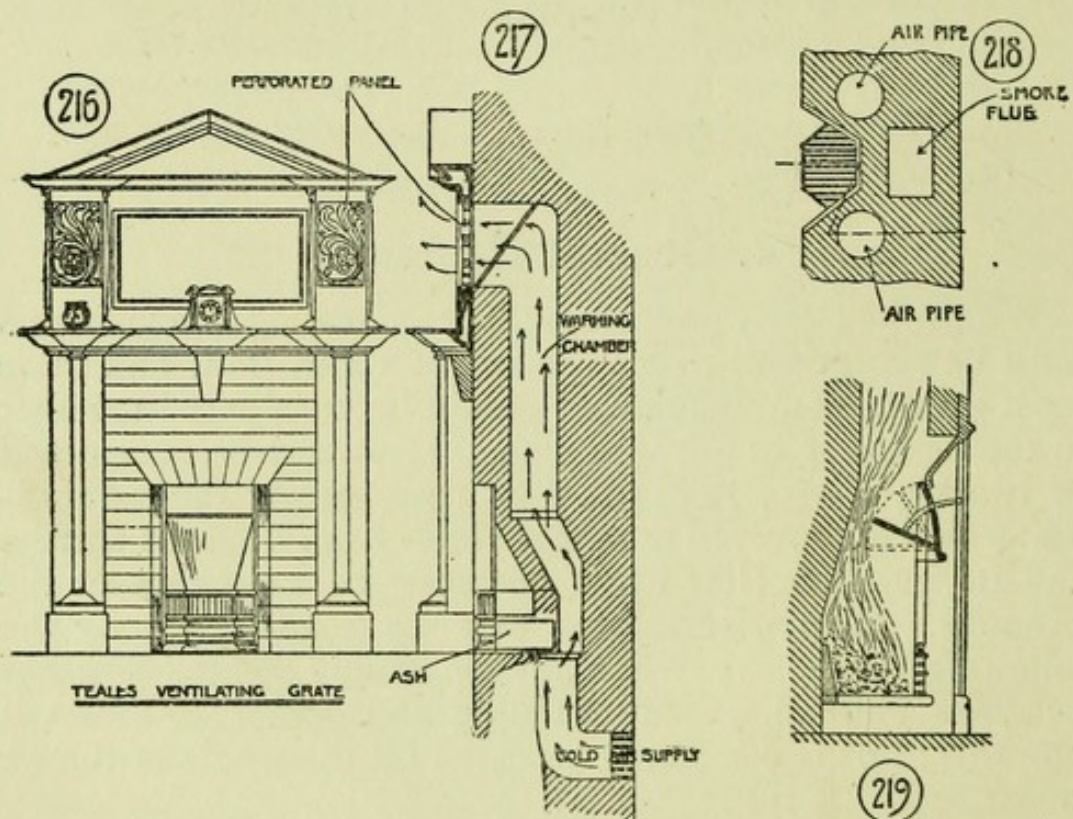

systems, and it is, as a rule, a mistake to depart materially from Teale's ideas as before expressed.

Fig. 219 shows Dr. Lee's patent fire regulator, and is a very simple and scientific appliance. It will be seen from the section that practically it is a blower fitted with a damper. It has been found that 30 to 50 per cent. of fuel can be saved by its use. When the fire is first lighted the regulator can be pulled up by the ratchet, and when it is well alight the regulator can be arranged horizontally over the fire so as to control the draught and combustion. It

can be fitted practically to any grate, and when the fire is not in use it can be detached and stored away. It has undergone scientific tests with most satisfactory results. By its means a considerable diminution of draught occurs up the chimney, thus preventing a room from being draughty. In consequence of this diminution the heating capacity of a fire is conserved, and sent into the room instead of being drawn up the chimney. It also appears that the regulator acts to a certain extent as a smoke consumer.

A recent contrivance in fire-bricks is shown in fig. 246. They are known as the **Flaming Kitchener Cheek**, and the advantages claimed are (*a*) a continuous flow of flame; (*b*) more heat from less coal; (*c*) most of the smoke is consumed by the flaming brick; (*d*) flues require less sweeping; (*e*) ovens and boilers are more readily heated, and it burns economically any quality of coal. They are

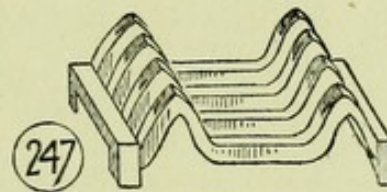
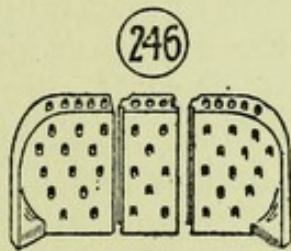

made of the best Stourbridge fire-clay, and are of the same size as the ordinary cheek, but perforated through the face with upwardly slanting holes, which ash cannot stop up while the fire is kept well raked. These front holes lead into central passages having an exit at the top, and through which the flames are drawn from the hottest part of the fire. These fire-brick cheeks become intensely and uniformly heated right through, which prevents them from cracking and scaling off, like the solid brick cheeks which suffer from irregular expansion caused by heat playing on one side only.

When fresh fuel is added, the new flames and gases have not to wait until they can force their way through the smoking tarry mass, because they find an easier passage through this red hot patent brick, even being drawn through the glowing embers, if previously heaped against the brick, and thus completing their combustion. The balance of the smoke and gases, which may not have been drawn through

the coals, fire, and flaming cheek, passes over the top holes, and is there ignited by the intensely hot flames issuing therefrom. The results are—little or no smoke or soot passing into the flues, and more heat generated from less coal. The lower parts and fire-side of the oven and boiler are rapidly heated through the thin back of the cheek.

Another patent recently placed on the market is shown in fig. 247, which represents what is known as the "Domestic Crater."

It is designed on the principle of creating an induced current of heated air to pass freely into the body of the fire, and thereby inducing more perfect combustion. It acts on the same principle as that involved in inserting a poker

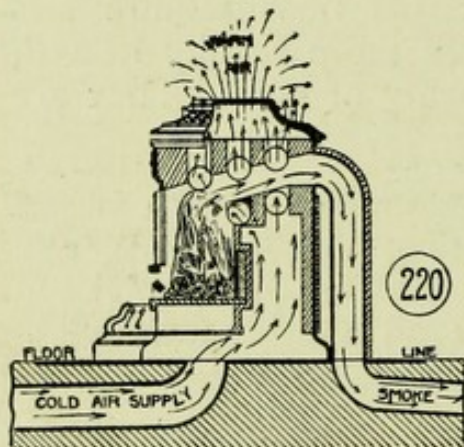

SECTION OF SHORLANDS PATENT
MANCHESTER STOVE

at the bottom of a fire to revive it. The principle is that the fuel is held up by the poker for a short time, and forms a hollow space inside the fire, allowing a free current of air to enter and pass into the fire. As the fire burns up the fuel settles down around the poker, and fills the hollow space, thus doing away with the air current. This difficulty is claimed to be remedied by the **crater**.

Gas is now used to some extent for grates, and especially in bed and other rooms which are not used continuously. If, however, the products of combustion are not carried off by a flue, they are unhealthy. Balls of asbestos and pumice are usually placed over a Bunsen burner, and being rendered incandescent produce considerable heat. Some of the later designs are modelled with the idea of providing a supply of heated air. It is probable that in the future *gas* kitcheners will be used more extensively for cooking purposes owing to their handiness and cleanliness.

3. Close Stoves.

There are many forms now in use ; the one shown in fig. 220 and made by Shorland, of Manchester, is, perhaps, one

of the best. They are economical but are liable to over dry the air and cause discomfort; they have the advantage of radiating heat all round, but they seem apt to char the organic matter in the air and cause carbonic oxide to be generated, the latter being injurious to health.

Fig. 230 represents the "Salamandre" stove supplied by the London Warming and Ventilation Company. It presents a cheerful appearance owing to the doors being fitted with mica panels, and the dampers are so arranged that when the stove is burning slowly the expense for fuel is reduced to a minimum, while by altering the regulator the heat may in five minutes be increased to its full capacity. It will burn continuously through a whole winter with **anthracite** at a cost not exceeding 3d. for every twenty-four hours. It can be placed in front of any grate or, if the latter be removed, it can be fixed in position with a perforated ventilating front.

The **fuel** used in all kinds of stoves has been considered by most people up to the present time simply from the standpoint of cost. There is no doubt, also, that the claims of **anthracite** have, to a large extent, been hidden from the public owing to the large interests of British capitalists in the smoky and unsatisfactory coal of everyday life. **Anthracite** is a natural coal which gives off no smoke, and it is sent out from the mines in various regulated sizes. Some fifty million tons are annually mined in the United States, and some two millions in South Wales, and some inferior qualities are found in other countries. The Americans export but little of their anthracite, but that from Wales appears to be freely sent to other countries. The British public may some day be sufficiently wise to retain in their own country the fuel which is the most economical, odourless, and smokeless that is known to mankind. The defenders of the filthy coal that fills our cities with dirt and soot, and veils our buildings in fogs and chokes our lungs with foreign matter, have stated that anthracite will not burn in open grates and should not be used for cooking purposes. As a fact, it burns better in

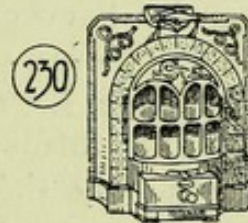

open grates, though perhaps requiring a little more wood in the kindling, and when once alight it requires but little attention if the ash is occasionally removed from the front bars and from the base of the grate. The cinders should be riddled and reburnt. For cooking anthracite is an ideal fuel, and for grilling purposes indispensable.

4. Hot Water Apparatus.

Under this heading we have to consider two distinct systems, commonly called

- (a) *Low Pressure*, and
- (b) *High Pressure*.

In both systems the circulation is due to the difference in weight of two columns of water connected together and in one continuous circuit. When one column is heated it expands, becomes lighter, and is forced upward by the heavier column pressing against its base.

(a) **The Low Pressure** system has many advantages over other forms of heating, the principal ones being that there is little risk of accident by fire, an even temperature is easily maintained, almost any kind of fuel can be used, and it is economical in its consumption thereof. Large pipes are used in this system, being generally 3 in. or 4 in. in diameter. Fig. 221 shows the application of this system. The flow-pipe should rise direct from the boiler to the highest level of the circulation, and the vertical fall of the return pipe should be designed as much as possible so as to be at the end of the circulation, in order to use the highest vertical column obtainable of the coldest water in the apparatus as the motive power. Dips as dotted at A and B tend to reverse the circulation, owing to the column of water that is farther from the boiler being cooler and heavier than that which is nearer. The nearer, however, that the dips are kept to the end of the circulation the less is their resistance. Escapes for air and steam are essential, and small pipes should be carried up well above the highest water level and should discharge into the open air. Boilers must be used that are suitable for the work required to be done. Hood's law on this subject is that one superficial

foot of direct heating surface will heat 50'0 of 4-in. pipes. It is found best in practice to add at least 25 per cent. of heating surface, owing to the liability of improperly swept flues and indifferent stoking. The ordinary saddle boiler as in fig. 222, is much used and is easy to manage. Chambered boilers, as in fig. 223, have a greater heating surface and are suitable for a larger system. Cornish and duplicate boilers are used in big schemes for schools and public buildings.

Fire Bars should, of course, have their areas in pro-

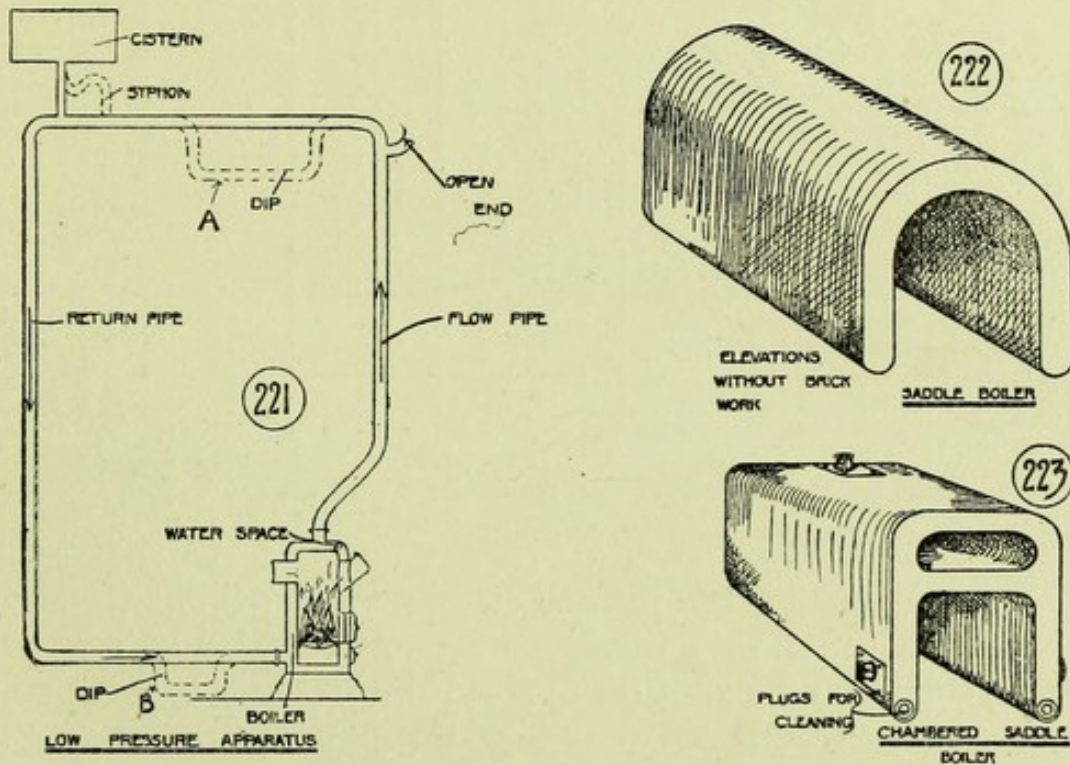

portion to the rest of the apparatus, and are not generally less than twenty square inches for every hundred feet superficial of radiating surface.

Chimneys should be well swept occasionally, and should be carried up a sufficient height so as to ensure a proper draught. They should not be less than 9 square inches in area for every hundred feet of radiating surface.

Pipes are generally of cast-iron in 9-ft. lengths, or in 6-ft. lengths if under 3 in. in diameter. They should be provided with sliding expansion joints to prevent their becoming inefficient owing to leaks. The other joints

much used in this country. They are superior to and much cleaner than cased coils, and are now much improved in design. Fig. 225 represents one that is frequently used.

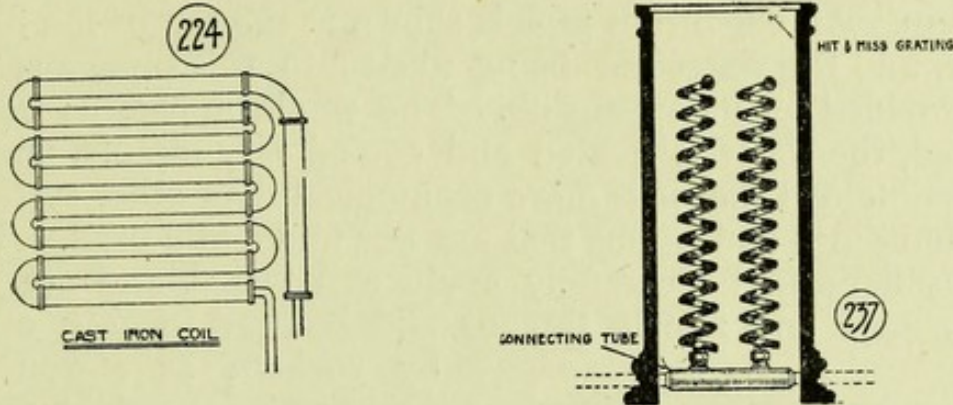

Gratings over pipes are to be avoided, though they are very generally in use for churches and chapels; the pipes underneath soon become covered with a layer of dust,

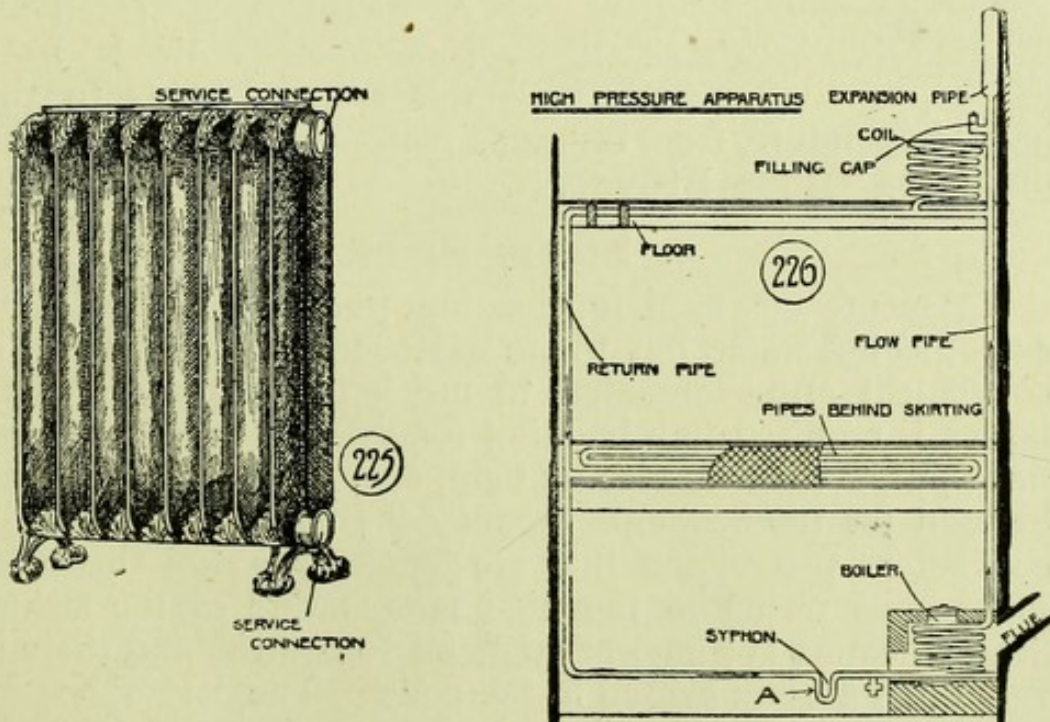

which not only gives forth offensive smells, but also acts as a non-conductive covering.

(b) **High Pressure Systems** consist of a continuous circuit of wrought-iron welded tubing, generally about $\frac{7}{8}$ in.

diameter. About one-tenth the total length of piping is formed into a coil and is placed in a fire-brick lined furnace, in which the temperature can be raised to about 380 deg. F. Fig. 226 is a sketch representing the principles of this system. An expansion pipe is shown at the top of the flow-pipe, and the water not being filled into this pipe, a space is provided for its expansion. The whole apparatus being sealed, the water is heated and cooled very rapidly, and it is maintained that it is more economical than other systems for buildings and rooms that are not frequently used. The pipes have to be carefully made and tested, and are cut with male and female threads and screwed to each other

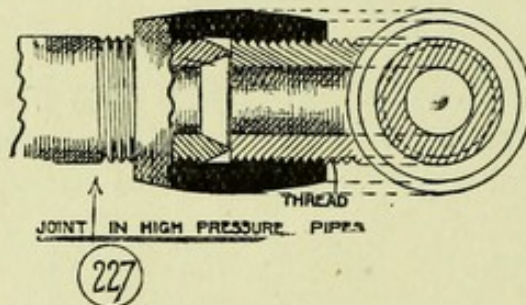

by sockets, as shown in fig. 227. A siphon, as shown at A in fig. 226, is placed near the boiler to prevent the water working back up the return pipe. A disagreeable smell is sometimes noticed from this system, owing to the

high temperature, from the same reason as mentioned when discussing **Close Stoves**.

5. Steam Pipes.

These are not used for heating purposes to the same extent as hot water, but where waste steam is available it is convenient and economical to use it for heating. Where power is required in a building for working an engine for trade purposes or for electric light, &c., the same boiler can be used for the heating. Steam coils may be arranged in convenient places, and they are smaller *pro ratâ* than hot-water coils owing to the high temperature of the steam. Steam heating is somewhat difficult to control, and there is very often a noise caused in the coils. The "low-pressure one-pipe gravity return" method is used considerably in Chicago. Low pressure is there defined as not being more than 15 lb. per square inch above atmospheric pressure. The "gravity" refers to the return of the condensed steam to the boiler, and the "one-pipe" refers to the supply to

the radiators of the steam, this same pipe draining off the water arising therefrom. Fig. 228 illustrates this method. There is, of course, but one valve to each radiator, which, when it is open, allows the steam to enter and the water to pass away; when shut, this radiator cools down without affecting the rest of the system. A person, therefore, cannot misuse the radiator in respect of leaving one valve open and one shut as in the case of the two-pipes system.

The effective system for the utilisation of exhaust or low-pressure steam as a means of heating by direct circulation has been extensively adopted in the United States under the patents of Messrs. Warren-Webster & Co., of New Jersey. The use of exhaust steam as a means of heating in this country has generally been confined to the working of low-pressure hot-water apparatus by means of heaters or calorifers. Under this system there is a considerable waste of steam in many cases, and the difficulties attending the deposit of scale upon the tubes of the calorifers are too well known to require further comment.

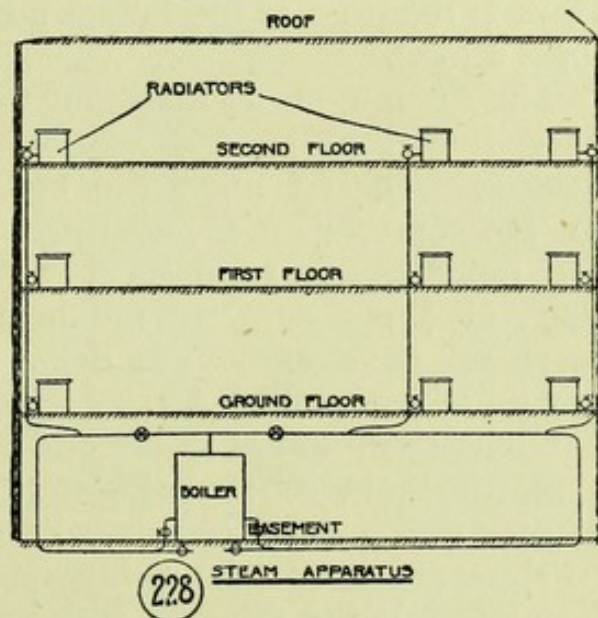

The general principle upon which the Warren-Webster system is based is the suction of low-pressure or exhaust steam through the radiators or coils by means of a vacuum pump connected to a central receiver. No matter how remote a point the steam may have to be taken to, the circulation may be relied upon. No air cocks are required upon any radiators or coils, all air and gases, together with the water of condensation, being returned to the central receiver, where the gases escape, and the water is returned as a feed to the boilers. Each radiator or coil is fitted with a thermostatic valve or steam trap of a novel and compact

description, exceedingly simple in principle and very effective in working. These valves are fixed on the outlets from the radiator to the return main. While a radiator is receiving its supply of steam, the valve remains closed, but it opens as soon as condensed water collects near the outlet—its action being very sensitive. Short circulating in any part of the system is thus effectually prevented. A special feature of the invention is the practicability of working the return mains from radiators situated below the level of the vacuum pump. With a vacuum of 15 in. it has been found possible to lift the condensed water in a return main with a difference in level of 7 ft. The feeder mains can be run without reference to levels if desired, but a thermostatic valve is required at the lowest point of each dip which may form a loop.

The common assumption that steam, at a pressure exceeding that of the atmosphere, does more work in heating is based upon the bare theory of the difference in temperatures. Comparing these, we find that while the latter is at 212 deg., a 5 lb. increase only adds 15 deg., or 7 per cent. to the heat supply, while a 10 lb. increase only adds 28 deg., or about 1.4 per cent. per lb. of pressure. As the removal of heat is effected by condensation, and is in direct degree due to that condensation, the gain in radiating power must be shown to be greater than 1.4 per cent. per lb. of back pressure, in order to show any economic advantage over atmospheric circulation; this is not the case with the ordinary radiator, which does not so effectively circulate the air over its surfaces as to secure such an advantage.

The special features of the Warren-Webster system may be summarised as follows:—

1. Entire absence of back pressure on engines when exhaust steam is utilised.
2. Continuous automatic drainage of condensation.
3. A thoroughly effective circulation.
4. Absolute control of temperature. The valve on the inlet to a radiator can be closed down to the desired degree, admitting a smaller amount of steam than it is calculated to condense normally. Without any "water hammering" the

radiator can then be kept, if desired, at a temperature just above that of the surrounding air, thus attaining that long-sought desideratum, the moderation of steam heating to suit mild weather.

Messrs. James Simpson & Co., of Pimlico, are now carrying out installations on these principles in England.

6. Hot-Air.

This form of heating may be accomplished in two ways, (a) by passing fresh air through a furnace and leading it through pipe-ducts to various parts of a building; (b) by passing fresh air over a coil of hot-water pipes and using the warmed air for inlet ventilation. The first method is not used to any great extent in this country, but it has its doughty champions across the "herring-pond." The second method is in considerable use, and may often be carried out to advantage. Fig. 229 shows the principles of the systems used in the House of Commons, the fresh air passing through cotton-wool screens and then through hot-water pipes into the air chamber. It then passes through the floor gratings to the House above. The smoke-flue in the clock tower forms the motive power for the extract. In this system dust particles are driven upwards from the floor and are inhaled into the lamp, and it has many other objections. In fact, it is not considered a successful scheme for the purpose. It is found in practice that the warmed air is advantageously brought in the apartments at a level of some 6 ft. from the floor.

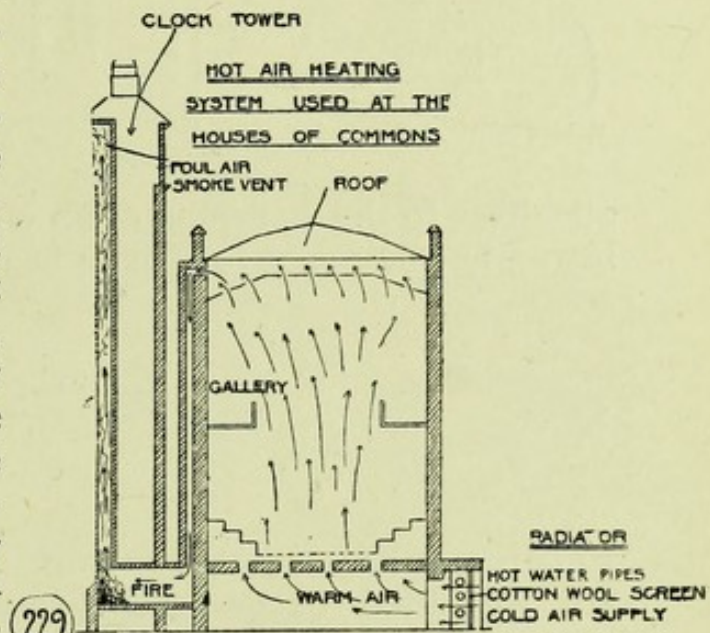

7. Electricity.

The cheerful appearance of an open fire would probably

prevent the very extended use of electricity for heating, even if the cost were of no consideration. However, that this may be accomplished with success is undeniable. Fig. 231 shows an electric radiator, which simply requires

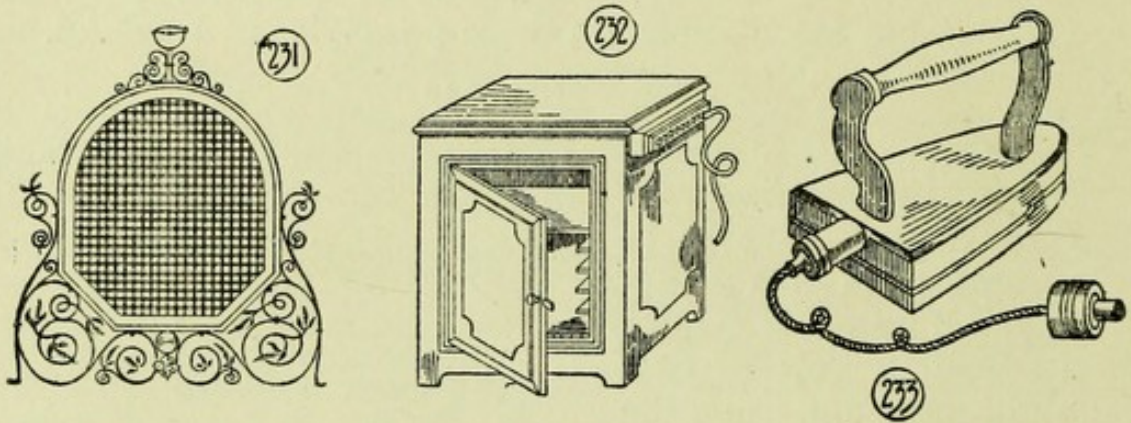

attaching to the wall-plug of an electric current when it will instantly commence to radiate heat. The electric current, in

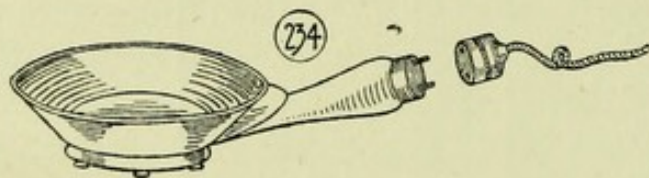

endeavouring to force its way through the small wire of the radiator, generates great heat, but the wire being buried in enamel,

which expands in the same proportion as itself, is not permitted to become a source of danger. Electric cooking-stoves are constructed on the same principle, and an illustration is shown in fig. 232; there are no fumes or smoke to taint the food being cooked; they are very cleanly, and take up little room. Figs. 233, 234, and 235 show an electric flat-iron, saucepan, and kettle that have been successfully used. Electric hot-plates are also designed and found useful in places where the current is available

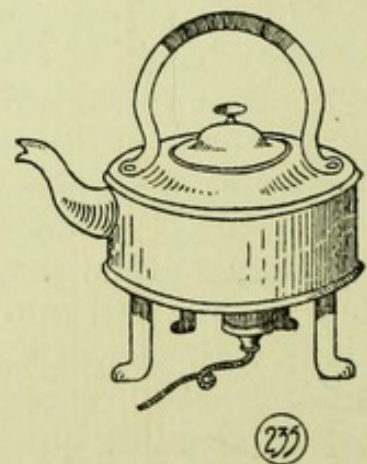

The cost is the great drawback to cooking by electricity, but the time must come when this will be reduced. At 3d. per unit, however, the cost is almost three times as great as

ordinary coal for the same purpose, but electrical ironing (see fig. 233) is said not to be more expensive, besides being so much handier in every way. In Edinburgh, where current for heating is $1\frac{1}{2}$ d. or 2d., the difference in cost should not stop people from using electricity for this purpose. In country houses where an installation has been put in, it will be found convenient when the current is plentiful to use electric radiators for airing the rooms, &c.; they, of course, are portable, and are very useful for this purpose.

8. Hot-Water Supply.

The same principles as for heating buildings are embodied in the domestic supply of hot water. The pipes should not be of less diameter than 1 in., and for big public institutions are even used up to $2\frac{1}{2}$ in.; they should be of wrought galvanised iron. Lead pipes are apt to sag, and thus impede the circulation. Boilers should have a safety valve attached to a pipe that is not in connection with the circulation system. There are three systems in use viz. :—

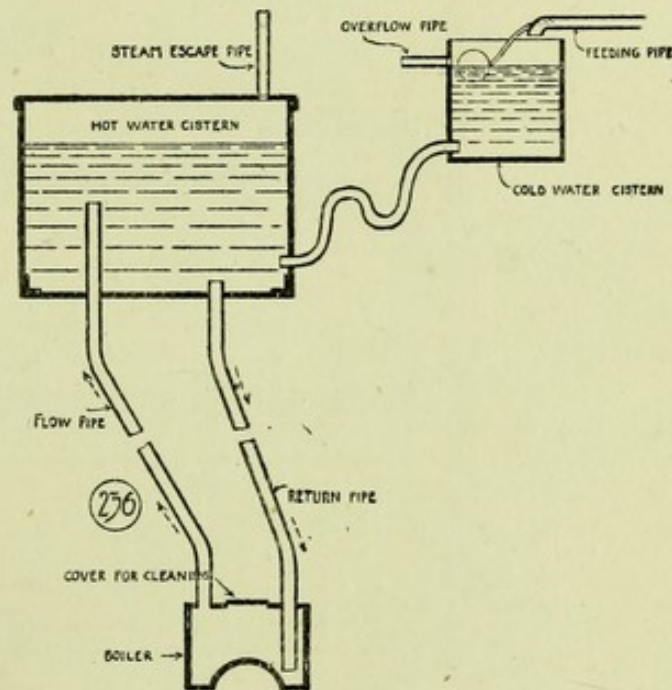

- (a) *The Tank System.*
- (b) *The Cylinder System.*
- (c) *A Coil Enclosed in a Cylinder.*

(a) **The Tank System** is the one that is, perhaps, in more general use at the present time. Fig. 236 shows the principles involved, and fig. 238 shows its application. The feed-cistern, which is controlled by a ball-valve, is fed from the cold-water cistern, and in turn supplies the hot-water

cistern, being connected thereto with a siphon. All these are placed at the top of the system. The **flow-pipe** is connected to the top of the boiler, and the **return-pipe** to the bottom. All branch pipes supplying hot water to the various fittings should be connected to both of the above pipes, and should enter the **return-pipes** at a lower level than at that from which they receive the **flow**. Where, however, a fitting is very adjacent to the **flow-pipe** this is not so necessary, as the amount of cold water to be drawn out

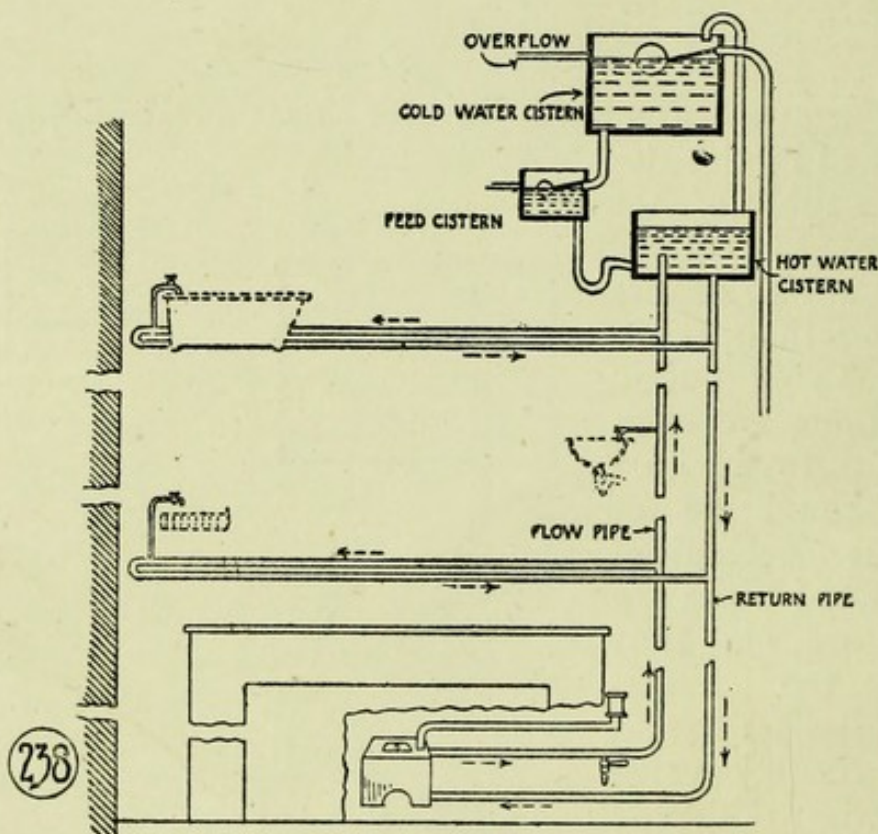

of the branch pipe (which, of course, does not form part of the circulation) before receiving the hot water from the flow-pipe, is small. In the case of a bath it is not so material to have the dual connection. An escape-pipe for steam and air should be carried up above the level of the cold-water cistern, and be connected to the top of the hot-water tank.

The boiler in small systems is generally heated by the kitchen fire, and is of the saddle variety. Where, however, a large supply is required this independent boiler must be used.

(b) **The Cylinder System.**—Fig. 239 is now generally recognised to possess some important advantages over the **tank system**, the most apparent being that—

- I. The system operates more quickly.
- II. Temporary failure of supply does not stop the circulation.
- III. More hot water is withdrawn before the temperature is lowered.
- IV. Risk of incrustation to pipes is less owing to the

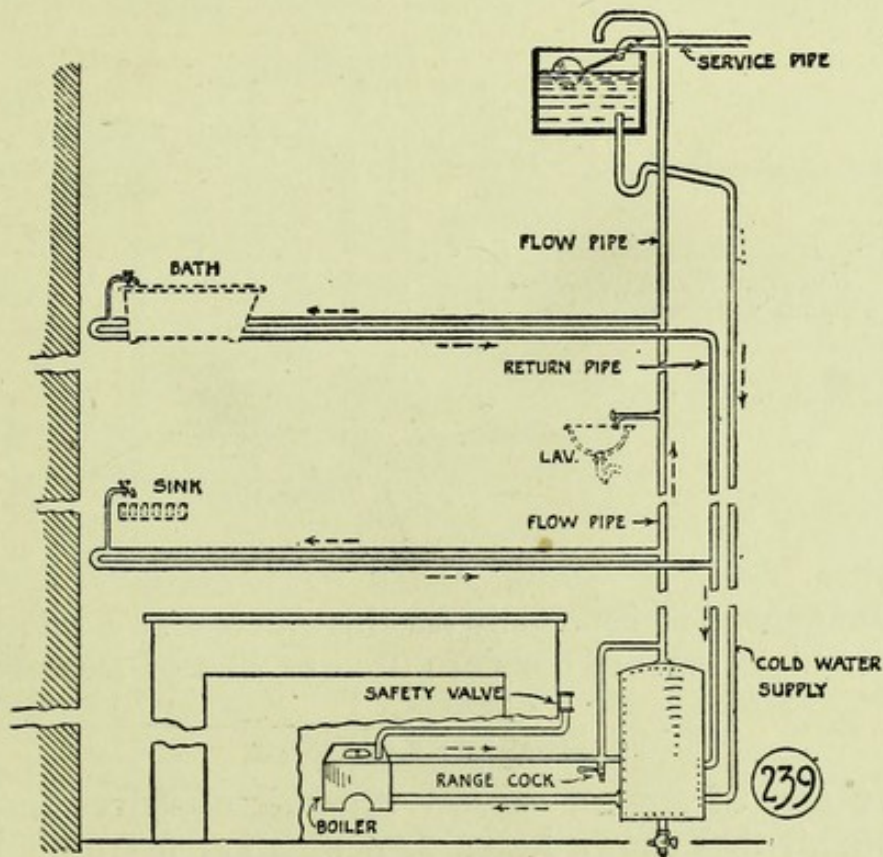

shorter circulation of pipes between the boiler and the cylinder.

The principal difference lies in the fact that the reserve of hot water is at the base of the flow-pipe instead of at the top, as in the *tank* system. Care should be taken that the *cylinder* is a strong one, and that its cubical capacity is sufficient for the purpose required.

Either of the above systems may also be used for the dual purpose of heating various parts of the house as well

as for the hot-water supply, provided that the boiler is large enough; and a towel-drier of piping in the bath-room should always be provided where possible.

Fig. 244 shows Potterton's combined radiator and towel ailer. These are very convenient fixed in a bath-room, and, of course, can be used, if desired, for airing linen.

(c) **A Coil Enclosed in a Cylinder** (fig. 240) is sometimes used for heating water supply, and may be utilised with advantage where waste steam is available. As a rule, however, it is not advantageous to use this method if steam

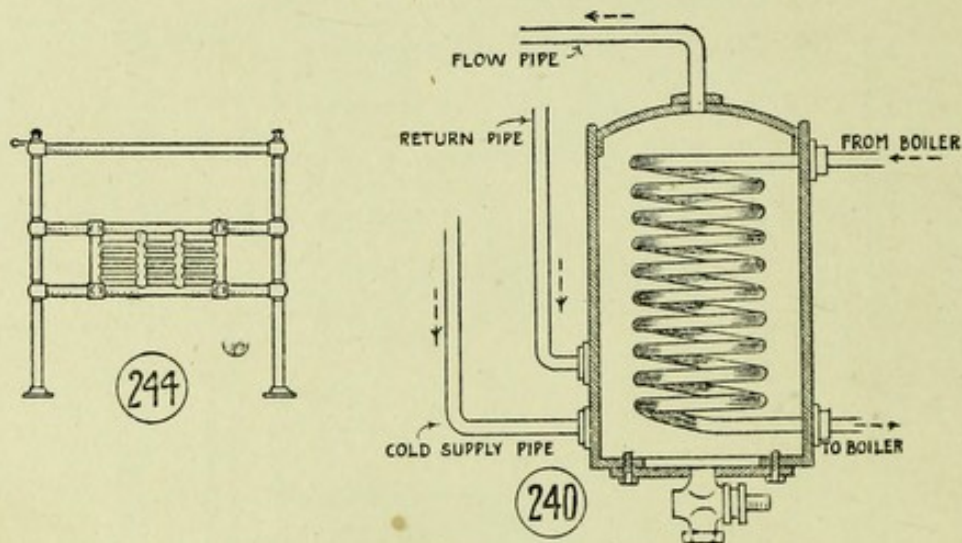

has to be generated especially for this purpose. Sometimes hot-water high-pressure coils are used in lieu of steam.

9. Safety Valves.

There are, of course, several varieties of valves in use, but probably that shown in fig. 241, which is patented by a Mr. Stainton, of London, is as good as any. It is known as a dead-weight relief valve. The advantage claimed is that, in the case of excessive pressure, the water finds an exit at the outlet A into the supply cistern, and as the water becomes cooled it returns through the inlet B, owing to the reduction of pressure in the pipe.

Fig. 242 shows one of Potterton's patent indicating safety valves, which contain the following improvement:—The spindles of these valves are made of brass tubing, with a small cock connected to the latter, so that water can be

drawn from the seating of the valve. If this is done it will indicate that the seating is free from incrustation, because if the seating became fixed by such cause, the hole at the bottom of the hollow spindle would be stopped up and no water could pass. The valve and pipe should, in this case, be disconnected and examined.

Fig. 243 shows a section of Shield's automatic air-valve. It is used for convenience where the usual air-cocks would be objectionable, and is said to be successful.

Smoke Prevention.—Fig. 245 shows Messrs. Belcher's prevention of smoke in steam boilers. The apparatus consists

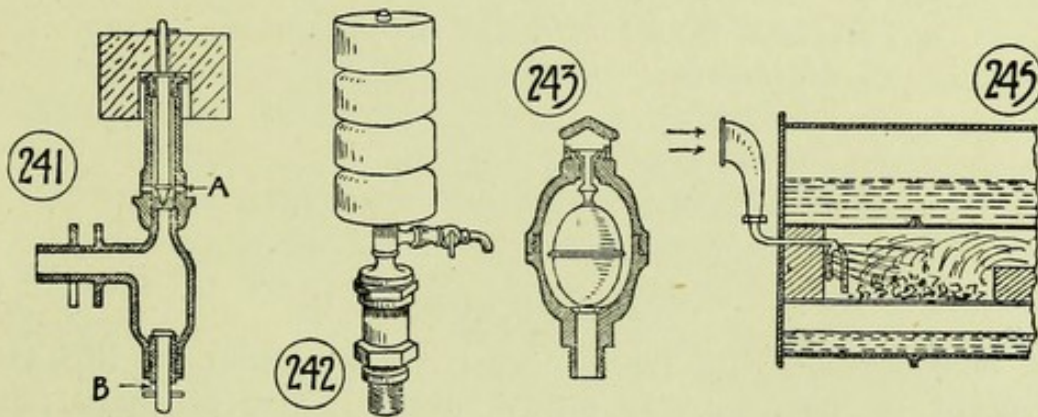

of an air-pipe fitted with regulating discs and with various valves and tubes fixed on the exterior of the boiler, by means of which a forced draught of air and steam is introduced into the fire, and by means of a "spreader" in the inside of the furnace the draught is concentrated upon the fuel.

The advantages claimed are simplicity in construction, necessitating no structural alterations to boilers; it is also under perfect control, and enables steam-power users to burn the cheapest fuel and even refuse without producing smoke.

CHAPTER XV.

Ventilation and Heating Schemes.

- a. Cottages.*
- b. Houses.*
- c. Churches.*
- d. Schools (class-rooms).*
- e. Hall (open timbered roof).*
- f. Large Hall (with flat ceiling).*
- g. Hospitals.*
- h. Theatres.*
- j. Picture Galleries.*
- k. A Chapel with gallery round three sides.*
- l. A Billiard Room.*

(a) Cottages.

It is notorious that people who live an open air life are content to live in very stuffy rooms. The ordinary cottager is certainly satisfied to do so, and even if architects provide air bricks or tubes, they are immediately blocked up. This is really very natural because small rooms are specially difficult to ventilate without draught, and, of course, expense would prevent any scheme of ventilation other than a natural one being employed. The open fireplace then is, as a rule, the sole agent, but occasionally a ventilating fireplace of the Galton pattern (as already ascribed and illustrated) is employed, or if not, then a Teale fireplace with economiser grate may be used, as less draughts are likely to occur with these.

The upper rooms may be kept at an equable temperature, by the use of ventilating fanlights over the internal doors, the chimney acting as an extract.

(b) Houses.

So much depends upon the size of the house and the money which the owner can afford to expend on ventilation that it is difficult to lay down more than general rules.

Firstly, as to the **Hall and Staircase**.—An improperly warmed and ventilated staircase is the cause of draughts and chill.

The best way to prevent this is by means of hot-water coils placed so that the incoming air from the front door may be warmed, and so that the large amount of air in a hall and staircase may not be at a much lower temperature than the air of the rooms themselves. Fresh warmed air can be introduced over this coil. By properly heating this portion of the house, all the rooms abutting thereon are rendered more habitable, especially in cold weather, as the warmed air enters them and finds an exit in their fireplaces.

Again, when sitting-room doors are opened a cold blast of air does not penetrate and cause colds and coughs. The great secret of a warmed and ventilated house lies in thoroughly attending to the hall and staircase, and no system will be found complete until this is taken in hand. An exit for foul air should be provided wherever possible into an air flue in the upper part of house, or by means of a lantern light fitted with extract coil. In this case, it is best to create an up current and thus prevent a down draught by placing a coil of water pipes as a lining to the lantern.

The air in the hall and living rooms should be as nearly as possible of the same temperature, if draughts are to be prevented, and to keep the air of the house pure and sweet both will intermingle with advantage. If warmed air is introduced into the hall, and fanlights are arranged above the doors of the rooms, a continual stream of warmed fresh air is supplied to the house.

As regards **kitchen, scullery, and offices**, and rooms containing sanitary fittings, and cellars, however, we should have another object in view, and that is to disconnect these as much as possible from the living portion.

We have endeavoured to show this in our article on "planning" (Chapter IV.).

As to the kitchen, if possible, cross ventilation should be provided, so that the fumes may be dispersed as soon as possible, and a cross ventilating corridor should always be so planned that kitchen smells may be prevented from entering the living part of the house.

As to the lavatories and water-closets an ideal arrangement is that which obtains in hospitals. This is, however, rarely done, and it is doubtful if it is always necessary. The usual way is to place the lavatory, which may also form a cloak-room, so as to be entered from the hall, and this in itself forms a disconnecting lobby; it should be provided, if possible, with two windows, so that "through" or "cross" ventilation may be obtained, and therefore effective disconnection of the water-closet from the main portion of the house. In order to ventilate the water-closet itself, louvres, or a grating, may be placed in the lower part of the door connecting it with the lavatory, so that air may be allowed to enter from the lobby and escape through the water-closet window.

Cellars should be cut off from the living portion of the house by cross ventilating lobbies. This is necessary in order that the damp, cold air may not be drawn into the house, and that the dust from coal-cellars and underground passages, the fumes from water-closets, and decaying matter from dust-bins and refuse may not be drawn up by the warm house air.

Bedrooms.—Every bedroom should, of course, have a fireplace, and the inlet to the flue should always be kept open, so that a current of air may always be travelling up the flue.

The old form of grate, with a register which can be shut down, should be avoided, as ignorant people seem very fond of shutting this, in which case the bedroom becomes a mere box without outlet. A bedroom in which the register is pulled down is almost certain to produce a headache by the morning.

People who desire to be healthy have their windows open an inch or so all the year round; but if this is objected to, a ventilating grating over the doorway should be provided, so that the fresh air admitted to the hall, after being warmed by the radiator, can pass through the bedrooms and so up the fireplaces.

(c) Churches.

In this class of building 500 ft. per hour per person may be taken as a standard. The motive power for the extract

may be produced either by a shaft in the tower, which may be heated by a coke furnace or gas, or by a fan worked by a gas engine. The inlet of fresh air may be introduced at different points over hot-water radiators, or by air which passes through a chamber filled with hot-water pipes and delivered to various points in the church. Hot-water piping, either raised above the floor on the outside walls or in channels below the floor when placed in aisles, are also used. Extracts can be taken into the roof at various points, and either led into the tower shaft, or aided by gas or a hot-water or steam coil to find its exit in an extract ventilator.

In lofty churches with clearstories the windows may be in two thicknesses of glass, and very often a hot-water flow and return can be carried round at the clearstory level, which will warm the air at this cold part and prevent the down draught, which is so objectionable.

(d) Schools.

This type of building is one of the most important as one of the most difficult to ventilate.

Important, because, if properly ventilated, it prevents the spread of infectious diseases and increases the working power of the students and teachers, and keeps them in better health and spirits.

Difficult, because of the number and different sizes of the class-rooms, the number of students in each, the varying length of time for which each is used. The various positions of the different class-rooms must be also taken into account, as, for instance, a room with a southern temperature requires less heat than one exposed to a north-east aspect.

The system, therefore, that appeals to us is one in which each room can be independently kept at a required temperature. The idiosyncrasies of masters have also to be taken into account; these should only be allowed play within a certain limit.

The Education Department requires fresh-air inlets equal to $2\frac{1}{2}$ square inches per scholar, and outlets equal to 2 square inches per scholar, in addition to the fire-place chimney.

In Mr. Robins's work on "Technical School and College Building," a careful survey is made of the ventilation arrangements of recent schools.

The three methods are :—

1. Supply from one large heating chamber.
2. Supply from separate heating chambers.
3. Supply from cased coils in the rooms.

Whichever system is adopted, a separate heating surface giving radiation to each room should be adopted

An example of a school recently erected is given as an

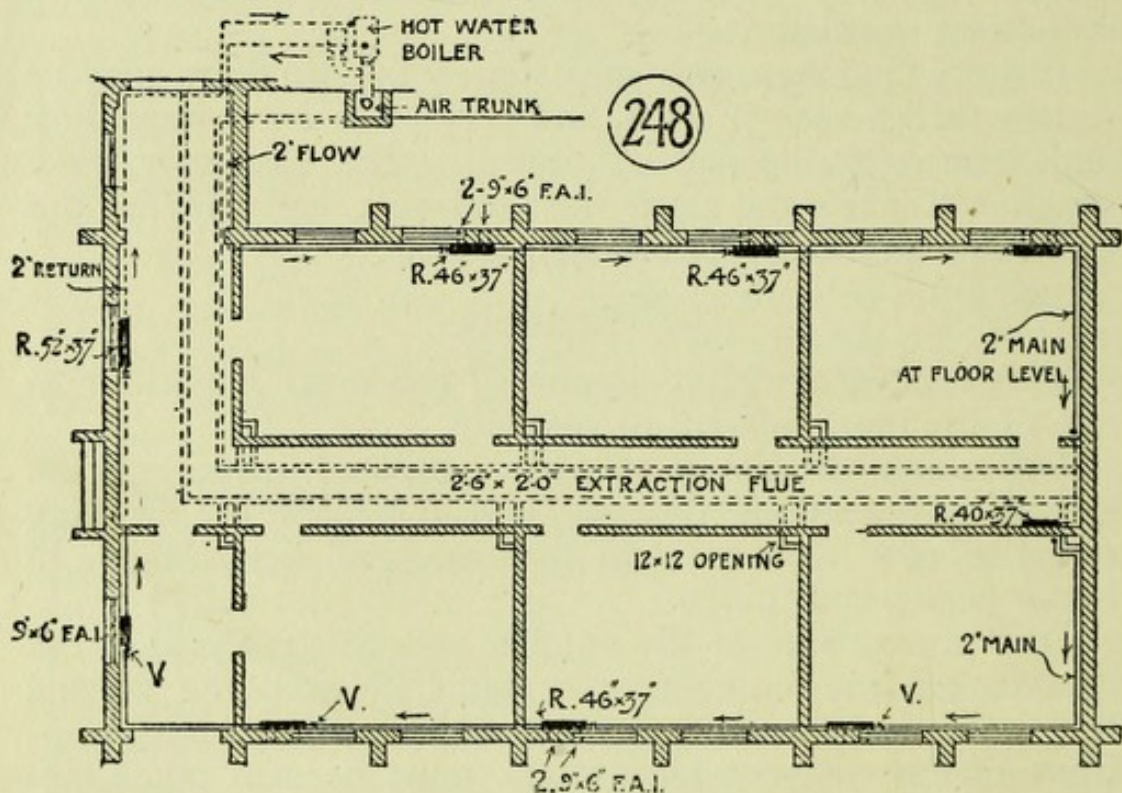
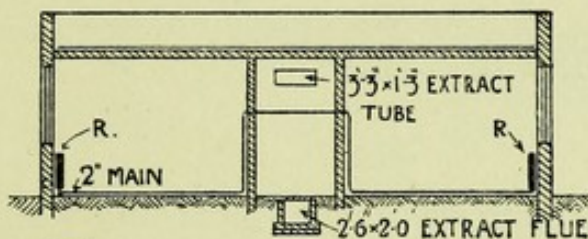

illustration of heating from one chamber by means of hot-water pipes and radiators, and an extract flue heated by carrying up the iron smoke pipe from the boiler in a brick flue, which thus is heated to act as an exhaust for the vitiated air of the class-room, which is led into it by brick ducts.

In this case (figs. 248 and 249) the class-rooms are warmed by means of one ventilating radiator fixed in each class-room over a 2-in. cast-iron circulating pipe as shown in the drawing. Fresh air is admitted to these radiators by

two 9 in. by 6 in. cast-iron galvanised fresh-air inlet gratings, with regulating gratings at the back of each radiator, so that after being warmed it enters the room. Each radiator is fixed above the circulating main and fitted with regulating valve and unions, so that each class-room can be regulated or shut off as required by the master in charge, with the exception of the circulating-pipe at the skirting level. The passages are warmed in a similar way. The heating apparatus is worked from a boiler fixed in the basement where shown on plan. As to the ventilation, it was considered necessary to change the air of the class-rooms three times an hour. The up-cast flue-pipe from the boiler acts as the extracting power. This is enclosed in a brick air-trunk 2 ft. 6 in. square, and the vitiated air from the



249

REFERENCES

- F.A.I. FRESH AIR INLET
- O. OUTLET
- R. RADIATOR
- V. VALVE

class-rooms is introduced into this space round the flue-pipe, and the up-current is started by the heated surface of the flue-pipe. The exit of foul air from the class-rooms is led by means of a cast-iron extraction - grating at the high-level and of different sectional areas

to each class, because of its length from the up-cast flue. The foul air descends by brick flues in the corner of each room into a brick channel formed into the floor of the passage, 2 ft. 6 in. by 2 ft. in the clear. This vitiated air-channel is connected with the up-cast flue as shown.

In the summer, when the heating apparatus will not be working, an open-fire coke stove placed next to the boiler in the basement and with flue taken into the cast-iron flue pipe, is kept going, so that the vitiated air trunk is always heated and the attraction formed in the ventilating flues winter and summer.

As to the practical working, one of the end class-rooms is taken, as being the most difficult to heat :—

Heating—Cubic contents of class-room 24 ft. \times 17 ft. \times 12 ft. = 4,896 cubic feet.

Change air three times per hour = $4,896 \times 3 = 14,688$ cubic feet.

1 heat unit will raise 55 cubic feet one degree $\frac{14,688}{55}$
= 267 heat units.

Glass Surface.—Two windows about 5 ft. \times 3 ft. 11 in. = say, 39 square feet.

1 square foot of glass requires $\frac{92}{100}$ heat units = $39 \times \frac{92}{100} = 36$.

Wall Surface (outside only).—

One side wall 24 ft. \times 12 ft. = 288 square feet.

One end wall 17 ft. \times 12 ft. = 204 ,,

—————
492

1 square foot of wall surface requires $\frac{3}{10}$ heat unit.

$$\therefore 492 \times \frac{3}{10} = 147$$

$\therefore 267$ (cub. cont.) + 36 glass (surface) + 147 (wall surface)
= 450 heat units required per degree difference 60 deg.
internally when at 32 deg. externally = difference = 28 deg.

$$\therefore 450 \times 28 = 12,600 \text{ heat units.}$$

1 ft. super of hot-water surface gives off 175 heat units.

$\therefore 12,600 \div 175 = 72$ ft. super. of hot-water surface required.

One radiator = 51 ft. super.

42 ft. of 2 in. pipe = 21 ft. super.

Total feet super of hot-water —————
surface in room 72 ft. super.

Ventilation.—Cubic contents $4,896 \times 3$ times per hour = 14,688.

Velocity of extract = 6 ft. per second = 21,600 ft. per hour;
 $14,688 \div 21,600 = .68$ square feet outlet required
(.68 of square foot = 108 square inches).

Class-room nearest to the shaft has outlet 12 in. \times 9 in.

Class-room farthest from the shaft has outlet 18 in. \times 12 in.

Amount of air per hour for each pupil = $\frac{14.688}{30} = 489$
 cubic feet.

Thirty pupils would be the limit that should be allowed in the room, as a rule not more than twenty to twenty-five should be present.

Messrs. Rosser & Russell, of London, were the engineers who carried out this scheme.

(e) A Large Hall.

Fig. 250 is an example of a large hall for public meetings,

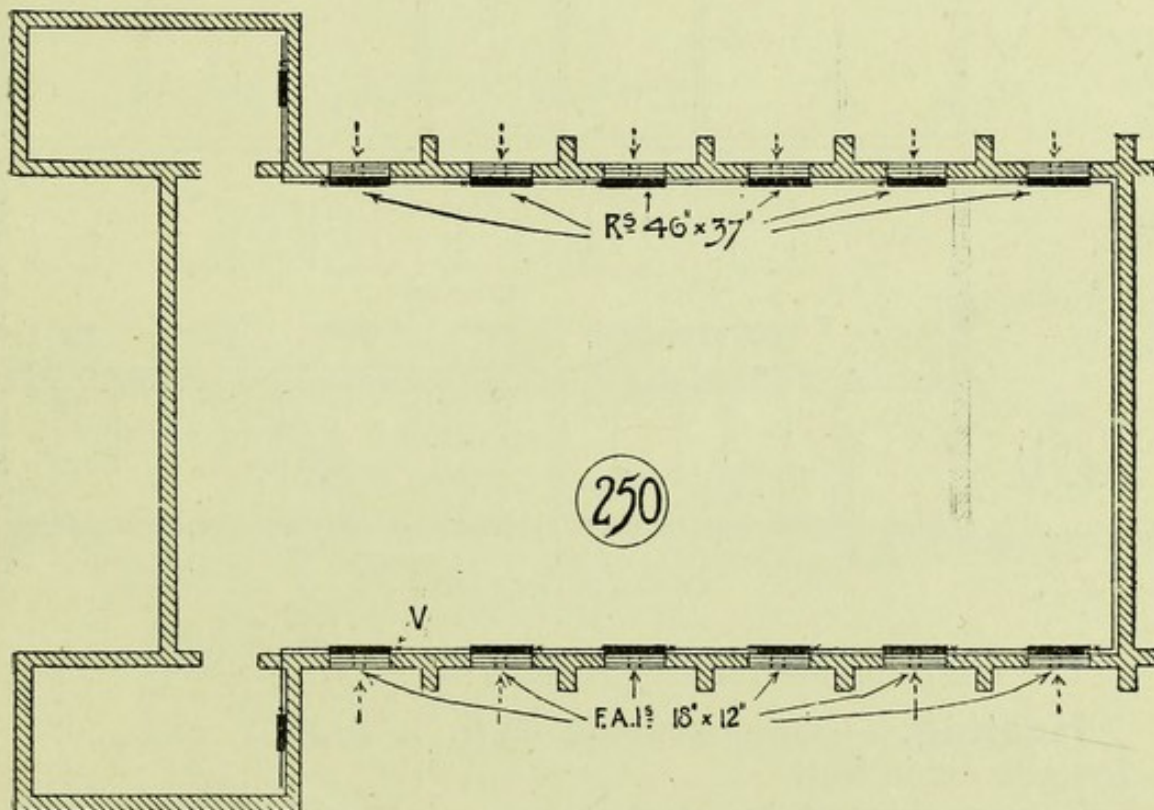

&c. It is 83 ft. long by 42 ft. wide, and is covered with an open-timber roof, the tie-beam of which is 20 ft. from the floor (fig. 251).

The heating was effected by a boiler of sufficient size in the basement. From this boiler a 3 in. flow and return main was carried to serve the hall and staircases, as shown on the plans. It is carried round the hall at the floor level. The hall itself is warmed with powerful hot-water ventilating radiators, each 46 in. long, $8\frac{3}{4}$ in. wide, and 37 in. high,

fitted with connections to the flow and return pipe, so as to be entirely under control. The ventilation is effected by means of 18 in. by 12 in. fresh-air inlets placed behind the ventilating radiators, external air bricks and internal hit-and-miss regulating gratings being supplied for each, the extract being by a powerful exhaust ventilator fitted at the ridge level.

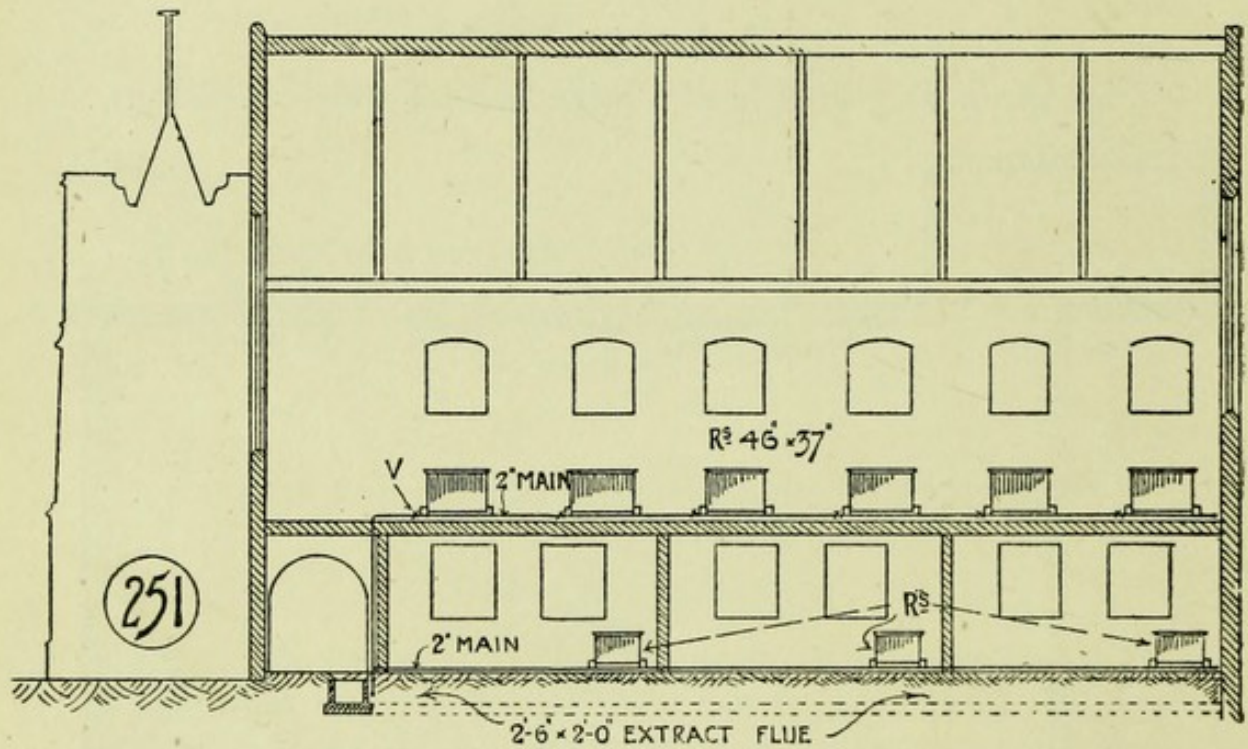

The following are the calculations:—

Heating.—Cubic contents 83 ft. × 42 ft. × 30 ft. = 104,580 cubic feet.

Change air once per hour.

1 heat unit will raise 55 cubic feet, 1 deg.

Heat Units.

$$\therefore 104,580 \div 55 = \dots 1,902$$

Glass.—

Ten windows 4 ft. 6 in. wide and 8 ft. high	360
Two windows 14 ft. wide and 14 ft. high ...	392

752

1 square foot of glass requires $\frac{92}{100}$ heat units.

$$752 \times \frac{92}{100} = \dots \quad 692$$

Wall Surface and Roof.—

Sides $83 \times 50 \times 2 = 8,300$

Ends $42 \times 30 \times 2 = 2,520$

10,820

Deduct glass 752

10,068

1 square foot requires $\frac{3}{10}$ heat units.

$$10,068 \times \frac{3}{10} = \dots \quad 3,018$$

5,612

5,612 heat units required per each degree of internal and external difference: 55 deg. internally when 30 deg. externally = 25 deg. difference.

$$5,612 \times 25 = 140,300$$

1 ft. super. H.W. surface gives off 175 heat units.

$140,300 \div 175 = 800$ sq. ft. heating surface.

188 ft. run 3-in. pipe = 165 ft. sup.

6 radiators at 106 ft. = 636

801 sq. ft. of heating surface.

Ventilation.—Cubic contents, 104,580.

Velocity of extract 6 ft. per second = 21,600 per hour.

$$104,580 \div 21,600 = 5 \text{ sq. ft.}$$

One extract ventilator 32 in. diameter (extract) = 5.5 sq. ft.

Six 18 in. \times 12 in. at $\frac{2}{3}$ of area = 6 sq. ft. (inlet).

(f) Hall (with Flat Plaster Ceiling).

(Figs. 252 and 253.)

This was a case in which the hall had been built for some time without being heated in any way; consequently, fresh

air had to be admitted cold, and the result was that this descended on to the heads of the defenceless occupants to

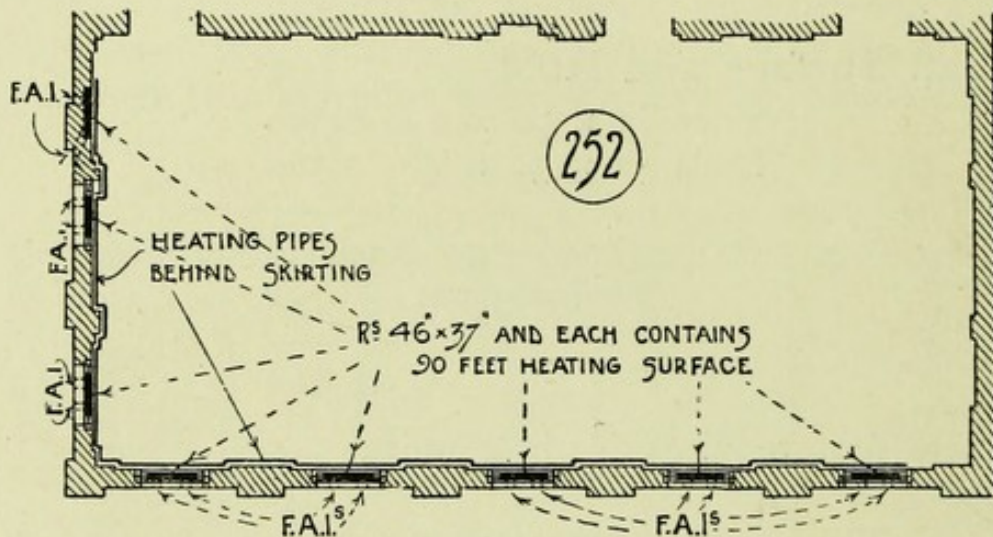

such an extent that at last they determined to adopt a proper scheme.

Ventilating radiators were placed in recesses under the windows and behind the oak panelling. Fresh air was admitted to these radiators by inlet gratings and, after being warmed, was admitted into the hall at a height of 6 ft. By this means the down draught from the big windows was prevented. The panelling in front of the radiators was lined with sheet-iron and *asbestic* so as to prevent the woodwork being affected by the heat. The extraction of vitiated air was provided for by means of the three sun-burners which had ventilating tubes taken to the outer air and up which a strong current was thus always

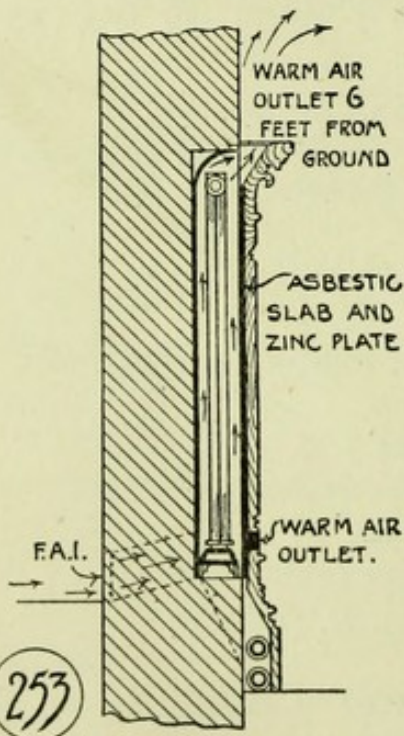

passing. Fig. 252 shows the plan and fig. 253 a detail of the radiators enclosed in the panelling.

(g) Hospitals.

The subject of hospital ventilation is such a large one, and the various types of hospital so many, that we can hardly do more than touch upon it here. At least 3,000 cubic feet per head per hour is quite the minimum amount of air which should be allowed, and the inlets and outlets may be provided in any of the ways already referred to. During the last few years mechanical means have been

employed for the purpose of securing ventilation. One of the largest and most complete installations on the "plenum" principle is that carried out at the Birmingham General Hospital (Mr. Henman, F.R.I.B.A., architect), in which no fireplaces are used, the air being forced in by fans, cleansed, and brought to a proper hygrostatic condition by filtering through moistened screens, warmed when required by means of steam coils, and propelled

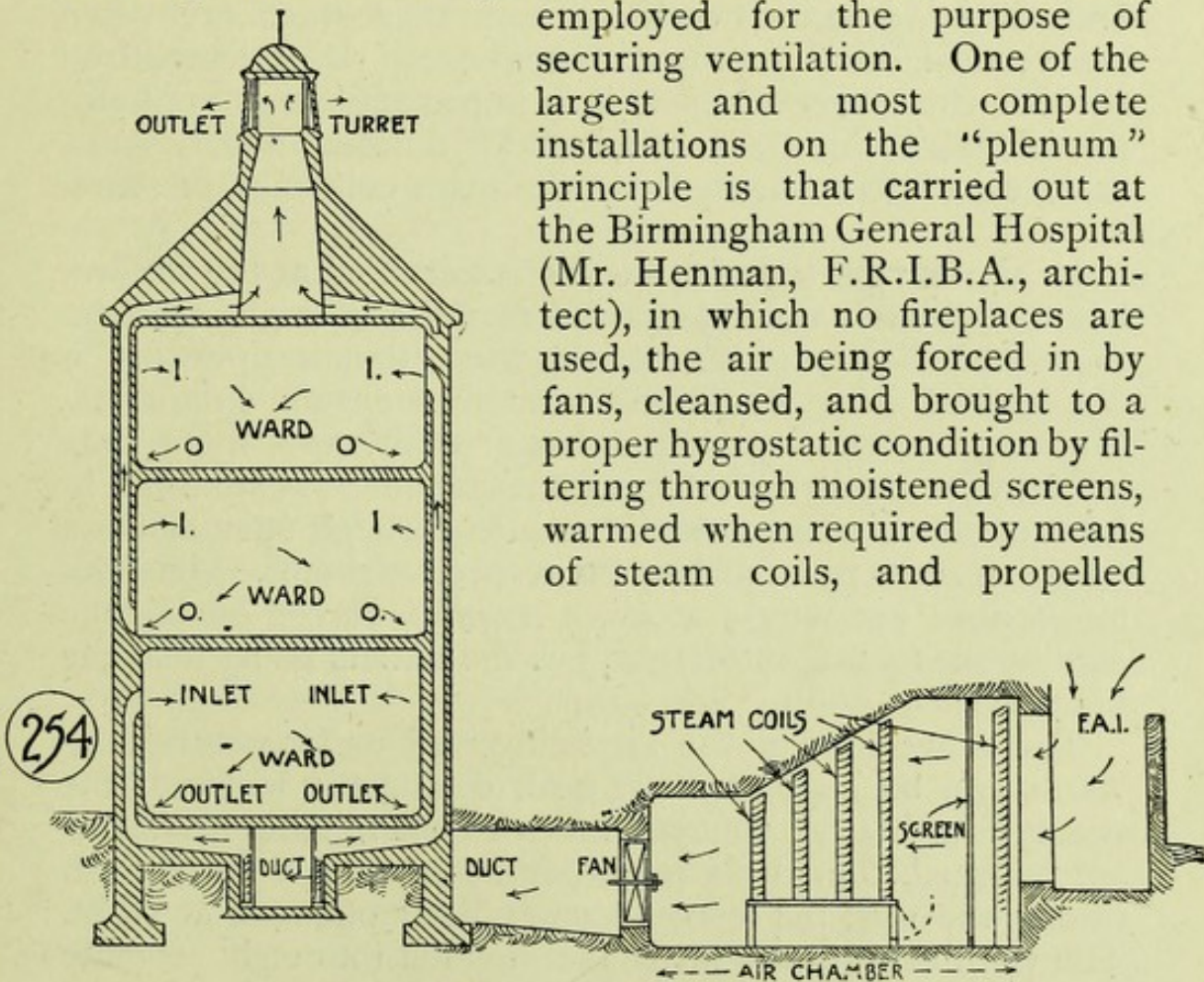

through the wards into extract flues, whence it passes into the open through flapped and louvred openings, constructed so that the varying movements of the outer atmosphere can exert no influence upon the outflow.

The illustration (fig. 254), from a drawing kindly supplied by Mr. Wm. Henman, shows the application of the system, which the following remarks will make clear. The air is sucked in from windows in the basement (carefully selected so

as to be out of the way of contaminated air) by a fan, passing first through a screen of strained cocoanut fibre, kept automatically wetted every quarter of an hour. The air is then carried through a series of horizontal steam-pipes, heated to the required temperature, then through the fan and into the basement tunnels. These tunnels (or "ducts" as they are called) start in sectional area 11 ft. by 8 ft., and only in a few cases are they so little as 3 ft. in width at the extreme ends in a few branch ducts. From these ducts are taken the vertical ducts to the rooms above. At the mouth of each of these vertical ducts is a **separate** steam radiator to give extra warmth if required for different departments, in excess of that supplied by the main collection of steam coils.

In the **large wards**, the air is admitted at the window boards behind a vertical glass screen, 18 in. high, in order to screen off direct draught and direct the air upwards; it is extracted near the floor in order to ensure circulation. However, it is only in the large wards, and there only partially for constructive reasons, that the air is admitted in front of the windows, elsewhere it is through openings at a height of about two-thirds of the respective rooms. The foul air is not "extracted" at all, it is simply forced out by the continuous forcing in of fresh air, the outlets being near the floor level.

The movement of the air being well under control, the wards can be kept perfectly fresh during the whole of the twenty-four hours; whereas in cases where natural systems are adopted, the wards may, perhaps, be kept fairly fresh during the day, but become particularly offensive at night. The ventilation of the hospital is divided into eight separate systems, worked by eight fans, but in case of the breakdown of a fan, two systems can be coupled and worked by one fan.

In smaller buildings, such as cottage hospitals, &c., the method of ventilation in military hospitals may be adopted. The room may be warmed by a Galton's ventilating grate, which forms an outlet and inlet.

Further, Sherringham's ventilators are provided as inlets; one square inch being allowed for each 60 cubic feet.

An additional outlet, consisting of 12 square inches to each man, is carried from the ceiling level to 6 ft. above the roof.

(h) Theatres.

The ventilation of theatres requires, as a rule, the advice of an expert. It is essential that all draughts should be carefully avoided, and for this reason the "plenum" method seems desirable, the air being admitted into a basement chamber, passed over hot water and steam pipes, screened and moistened by means of sprays of water, and so introduced by numerous openings as to thoroughly reach every part of the house. The use of electricity has facilitated matters by decreasing the amount of air which was formerly necessary to supply the old gas burners.

The Vienna Opera House is generally quoted as a perfect example. In this case the "plenum" and "vacuum" methods are employed, there being two fans, one for propulsion and the other for exhaust. The air is admitted through the floor and risers of seats.

The Metropolitan Opera House, New York, is ventilated on the "plenum" system only. During the day the building is highly heated so that the walls may be thoroughly warmed. Before the performance begins the temperature is lowered to the required point, and as the performance progresses and the heat from the audience is felt, the temperature is gradually lowered.

The older theatres in London are many of them most inefficiently ventilated, and it is high time that efficient ventilation is insisted upon before licences are granted. All public buildings have to be provided with an efficient water supply, which is supposed to be filtered by the companies before being delivered, and it is difficult to understand why a sufficient supply of pure fresh air, warmed to the proper temperature should not also be provided.

(j) Picture Galleries or Schools of Art.

In cases of this sort in which a large amount of glass in a skylight or lantern occurs in the top part of the room, difficulty is often experienced because of the down draught which comes from the cold surface of the glass.

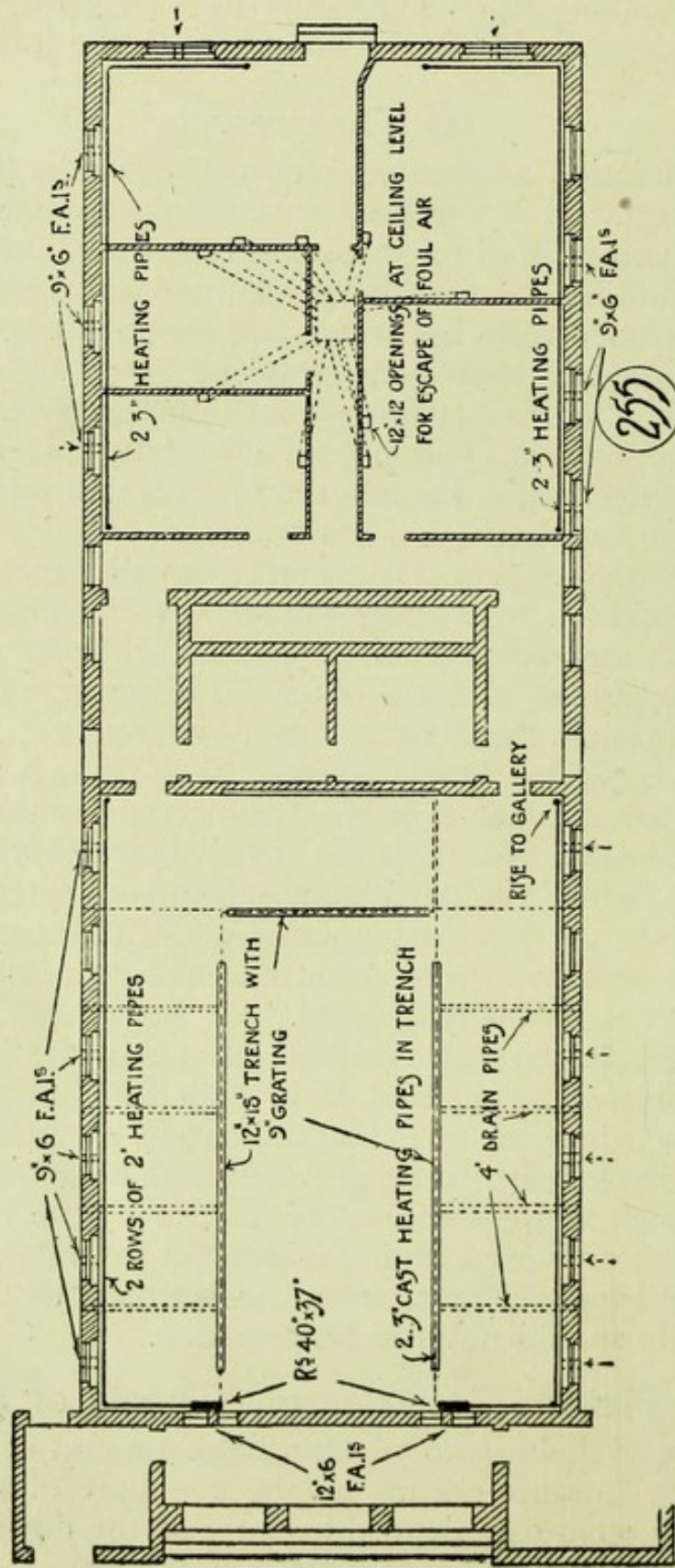

Powerful gas lights with ventilating tubes may be taken through the roof to induce an upcurrent, and inlet ventilators may be introduced 6 ft. from the floor in the four corners of the room.

(k) A Chapel with Galleries.

This is given as the fixed seats required a somewhat different arrangement. The chapel itself is warmed by means of two rows of 2-in. pipe each side and two rows of 3-in. pipes in a prepared trench, covered with cast-iron floor grating. Radiators are fixed near the entrance doors, so that the incoming air may be warmed. In order to prevent a down-draught from the large amount of cold air in the

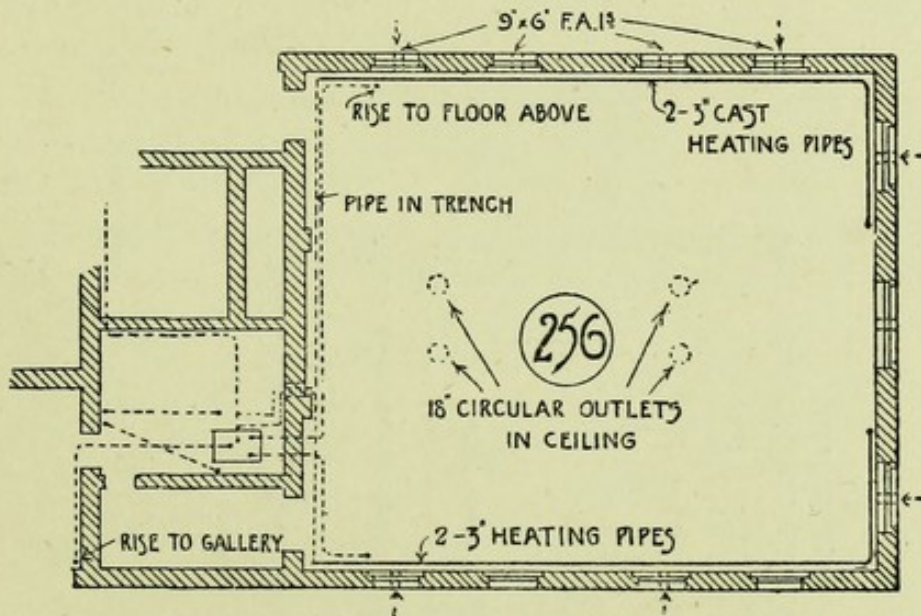

upper part of the hall, the gallery is heated by two rows of 2-in. pipes on each side of gallery. As to the ventilation, fresh air is admitted behind the radiators on ground floor, and into the trenches in the central part of chapel by means of air channels formed of glazed drain pipes which lead in an upward direction in the channel mentioned above. The extraction of foul air is effected by means of three gas sun-burners suspended from the roof with ventilating shafts leading into a galvanised iron vitiated air-trunk, taken into a central galvanised iron box on the top of which an extract ventilator is fixed, communicating with the outer air. Figs.

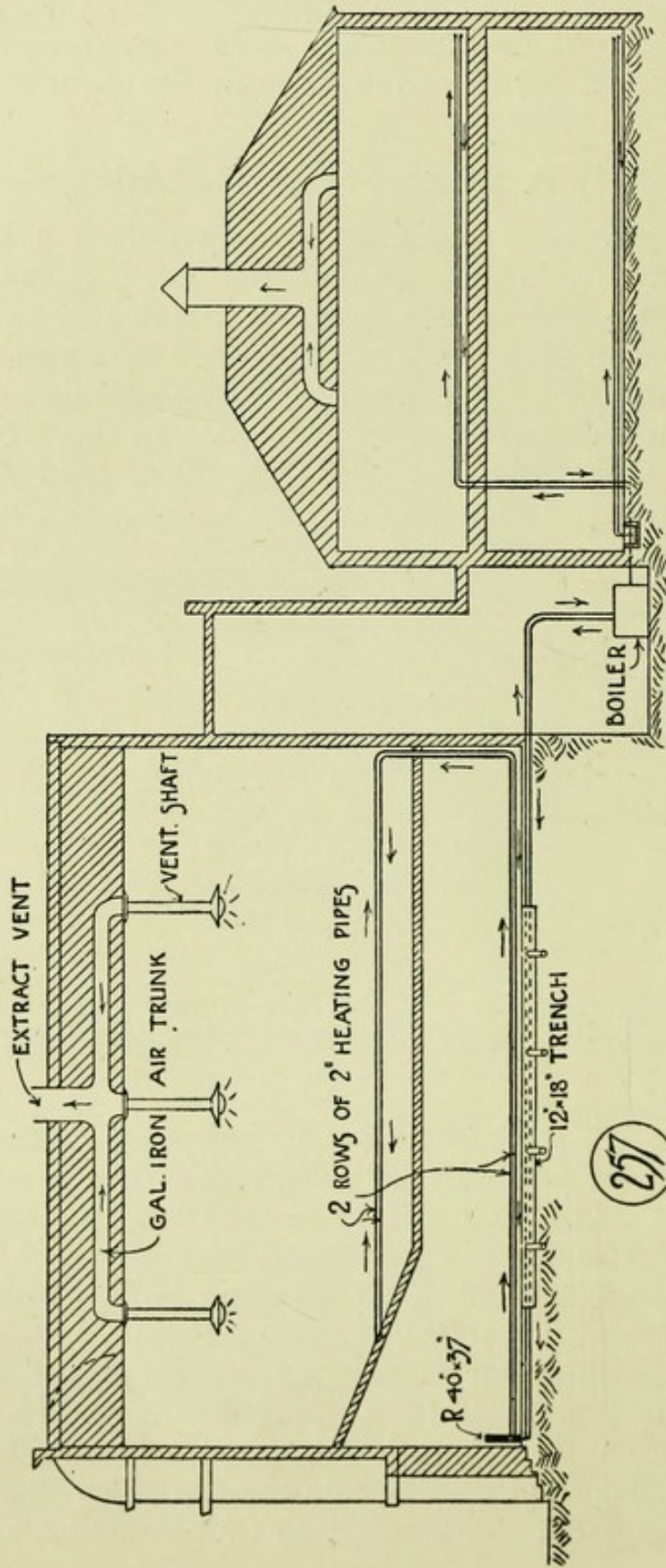

255, 256 show the ground floor and basement plans respectively and fig. 257 shows a section throughout.

(1) A Billiard-Room.

A billiard-room is very often difficult to ventilate because of the large amount of glass in the lantern which is necessary for lighting the table, and the enormous quantity of gas which is necessary for lighting. The first thing which should be done wherever possible is to substitute electricity for gas; this will simplify matters considerably. In order to prevent a down-draught from the cold air round the glass a "lay-light" or horizontal glass ceiling may be placed below the lantern, and the space thus formed warmed by a coil of hot-water pipes, so as to cause an up current, which can be taken through an ordinary extract ventilator. Fresh air should, of course, be made to enter by means of ventilating radiators from, if possible, the four corners of the room. If hot-water heating is not desired, a ventilating grate may be used, the lay-light made air tight, several Sherringham inlets placed in the walls, and the extract obtained by a special foul-air flue in the chimney-breast, with possibly a "pilot-light" or gas jet to accelerate the current.

CHAPTER XVI.

LIGHTING.

THE beneficial effect of sunlight upon the health of the human being is a matter of general knowledge, and it is recorded that the Romans of old used to indulge in *Solaria*, or baths of sunlight.

Modern medical authorities insist so strongly upon this necessity of sufficient light for the healthy condition of the human body that it behoves us to bestow more care upon this important subject than is usually given to it. Lighting may be conveniently considered under the following heads :—

1. *Solar Light.*
2. *Assisted Natural Lighting.*
3. *Artificial Lighting.*

I. Solar Light.

This was discovered by Newton to be a mixture, the whiteness of which is due to the proportions of its ingredients. By means of a prism of glass he threw a luminous band of light upon a screen, and this band was found to contain the following colours :—Red, green, violet, orange, yellow, blue, and indigo. The first three are the **primary** colours, and the others are an admixture caused by the overlapping of the adjacent bands in the prismatic spectrum. When an object is called a particular colour we mean that it gives free passage or reflection (as the case may be) to that particular colour or mixture of colours, and that it arrests or absorbs the remaining colours. Certain combinations and contrasts of colours are pleasing to the eye, and, according to Professor Barff, these are only existent when their combination, taken collectively, make up white light. When two or more colours of the spectrum

by being blended together produce white light, such colours are said to be **complementary** of each other.

Under this heading of solar light we will now consider :—

- (a) *The Question of the Admission of Solar Light to Buildings.*
- (b) *Relative Proportions of Windows.*
- (c) *Positions of Windows.*
- (d) *Glazing.*

(a) **The Question of the Admission of Solar Light to Buildings.**—We learn from the ancients that light has a greater illuminating value when admitted through a horizontal aperture in the ceiling, and no greater proof of this can be found than in the Pantheon at Rome. The diameter of the eye of this dome is only 27 ft., and yet one must admit that this building is comfortably and sufficiently lighted, though each superficial foot of lighting area has to suffice for nearly 3,400 cubic feet of the contents of this structure. However, it is not often given to the architect to top light many of his buildings, and we will not pursue this subject further. With regard to vertical apertures in walls, it is found that an odd number of windows in an apartment is advantageous, as it obviates a central pier, which latter is apt to give a gloomy effect. In a long and narrow room more effect is obtained by lighting from the ends than from the sides ; as if lighted by windows in the longer walls so very many more shadows would be cast. This is well exemplified in the ball-room at Windsor Castle, which is 90 ft. by 34 ft., and is 33 ft. high. It is illuminated by a northern window at one of the narrower sides, occupying nearly the whole width of the wall.

(b) **Relative Proportions of Windows.**—The question of climate must necessarily affect our calculations, and the laws laid down by Vitruvius, Palladio, and Scamozzi can scarcely be applicable to climates more distant from the equator, and influenced by local considerations, it being an axiom that smaller and fewer windows are required in a warmer climate. Sir William Chambers recommended adding the depth and height of the rooms on the principal floors together, and taking one-eighth part thereof for the

width of the window. Robert Morris recommended that the superficial area of the lighting surface should equal the square root of the cubical contents of the room in feet. Gwilt was of opinion that 1 ft. superficial of light in a vertical wall will in a square room be sufficient for 100 cube feet if placed centrally in such room. This is based on the supposition that the building is free from obstruction by high objects in the neighbourhood. The model by-laws of the Local Government Board state that the area of the windows in a room should be at least equal to one-tenth of the floor area of such room ; and this provision is also incorporated in the London Buildings Act of 1894.

(c) **Positions of Windows.**—One of the regulations of the Education Department is to the effect that school-desks should be lighted from the left-hand side. This is undoubtedly a wise precaution, for if the light be behind the student, the body will cast its shadow upon the work being done. If the light be on the right hand, the work will be in the shadow of that hand. And if the light be directly in front, the reflected light from the surface of the table is directed into the eyes of the worker, and consequently puts an increased strain upon them. Moreover, on raising the eyes, they are subjected to a greater illumination, which stimulates the effort of vision instead of resting the eyes when not at work, as is recommended by oculists.

It is obvious that no fixed rules can be laid down as to the positions of various rooms in relation to the points of the compass, as so much depends upon the various characteristics of the site and local considerations. However, it is well to remember that rooms which are constantly inhabited in the daytime should, wherever possible, have as much actual sunlight as can be obtained through skilful planning.

(d) **Glazing.**—Plate glass, though disagreeable in effect, has the practical advantage that it affords less resistance to the admission of light, and being of greater thickness it does not dissipate the heat of the room so quickly as sheet glass. Moreover, it is not so easily penetrated by sound. Cathedral tinted glass may be used in some situations, and it is claimed that it increases illumination owing to its texture. According to Sir David Brewster, all glass with a roughened

or fluted surface increases the amount of light that penetrates any window, but it should always be remembered that such surfaces are prone to harbour dust and dirt.

The following table shows the result of some recent experiments :—

Nature of Glass.	Percentage of Light Intercepted.
Polished British plate $\frac{1}{4}$ -in. thick	13
36-oz. sheet glass	22
Cast plate $\frac{1}{4}$ -in. thick	30
Rolled plate, four corrugations to 1 in.	53

2. Assisted Natural Lighting.

This is found necessary in rooms facing narrow thoroughfares and areas facing adjacent high buildings, and in basements and other places

where the solar rays have but limited access. The covering of the obstructive walls with white glazed tiles, or facing the same with white glazed bricks, does something to assist the reflection of light into such rooms. And the painting of the walls of the rooms in light colours, or even lining them with white

tiles, is found to be beneficial. It is also found that by keeping the window frame flush with the external face of the wall, more light is admitted into the room.

External Reflectors are sometimes placed outside windows for the purpose of reflecting light into the building. In America and Canada within the last few years the high buildings which have been erected have necessitated the adoption of some means of refracting the light to the lower windows, so as to carry the illumination to the back of the rooms. This has been effected to a larger extent by **Luxfer prisms** which have now been introduced to this country. They are designed upon the following principles :—

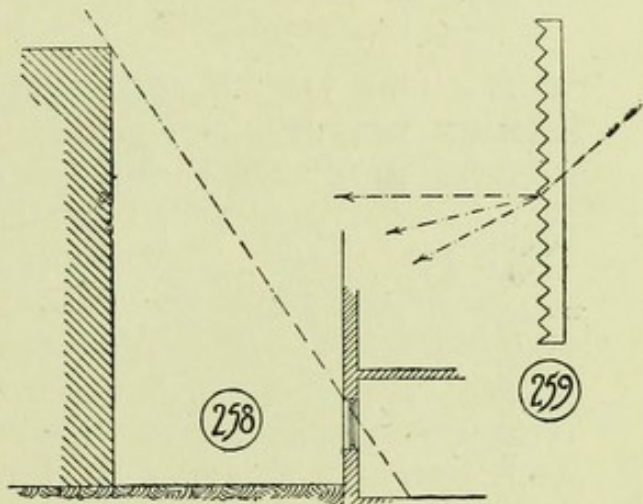

The direct natural light to an apartment coming from the sky is, to a large extent, absorbed by the floor, as shown in fig. 258, although even ordinary glass has some refractive influence upon light and thus bends some light into the

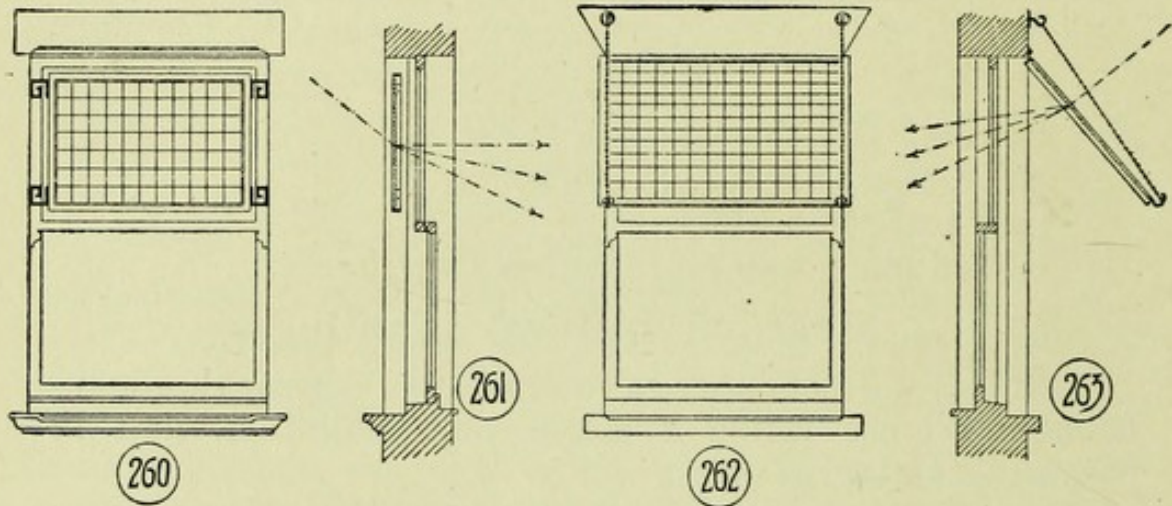

room. This law of refraction has been utilised in the **Luxfer prisms**, and the latter are so constructed and arranged to suit the varied cases that may arise. Fig. 259

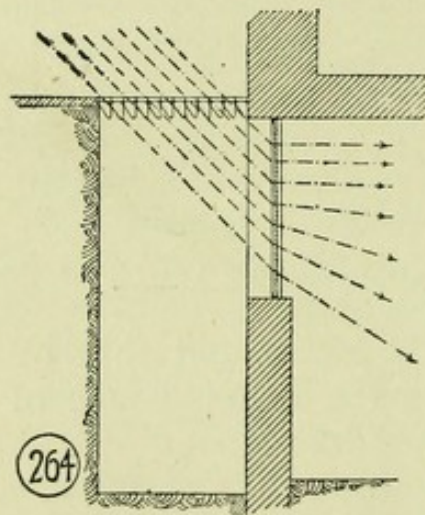

illustrates this principle. In upper floors these prisms are usually fixed in the upper half of the windows and nearly flush with the outer surface of the wall as shown in figs. 260 and 261. In the cases of very lofty buildings the lower windows have canopies as shown in figs. 262 and 263, so as to receive more light from the sky. Base-

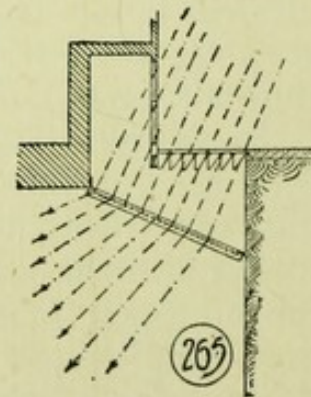

ments are lighted by pavement lenses which throw the light down on to a canopy fixed vertically, which, in its turn, refracts the light in a horizontal direction to the rear of the apartment as shown in fig. 264.

Where the pavement light is narrow and a high stallboard is permissible a sub-canopy may be used as shown in fig. 265.

3. Artificial Lighting.

This is caused by the heating of some substance till it becomes incandescent. Until electricity had been used in recent years for lighting this condition was solely obtained by using the heat developed during chemical change, but since the impeding of the conduction of an electric current was found to produce incandescence, this method of illumination has steadily increased. Owing, however, to the great gas monopolies and the conservative tendencies of the inhabitants of Great Britain, the progress has been much slower than in other countries. On the American continent electricity plays a far more important part in public and private enterprise.

We may consider this subject of artificial lighting under the following headings:—

- (a) *Candles and Lamps.*
- (b) *Gas.*
- (c) *The Electric Light.*

(a) **Candles and Lamps.**—For private dwellings there can be no question that illumination from candles and lamps is popular with certain people. Light for light, however, they are less healthy than gas; there is also more danger of a conflagration ensuing through their use unless great care is exercised. The low-flash oils, which are permitted to be sold to the poorer classes, so often occasion fires and loss of life, that some measures must surely soon be taken to modify this evil. The cheaper forms of lamps also are so dangerous that the wonder is that more accidents do not occur. It is estimated that two sperm candles or one good lamp render the air about as impure as one individual.

(b) **Gas**, as distilled from coal, was used by Mr. Murdoch, of Redruth, to light his own house at the end of the eighteenth century; but it was so impure as to render flues necessary to carry away the noxious odours. The lime process of purification, however, alleviated this nuisance, and allowed the use of naked flames. One gas burner will consume as much oxygen and give out as much carbonic acid as six men.

Illumination.—The standard method of measuring the power of illumination by gas is a spermaceti candle, burning 120 grains per hour, the consumption of the gas being reduced to 5 cubic feet per hour. The gas in the Metropolis should, by statute, be of the illuminating power of sixteen candles. The specific gravity of gas (assuming air as the unit) is, for ordinary calculations, assumed as 45.

The following table is published by Messrs. Stott as their idea of the light required for various purposes.

	Candle-power per 1,000 sq. ft. of area.
Country roads	$\frac{1}{2}$
Small towns	4
Large towns	10
Hospital wards	} 50 to 100
Barracks and drill-sheds ...	
Cottage parlours	150
Villa dining-rooms	250
Board schools	300
Churches and chapels	300
Banqueting halls, &c.	450

The above approximate calculations must, of course, be subject to the reflecting powers of the decorations and colours used in the various apartments.

Impurities in gas are limited more or less by the Act of 1868; the following are the usual tests. For ammonia redden yellow litmus paper with dilute acid and place it in a gas-jet; the presence of ammonia will turn it brown or restore more or less completely the original blue. Under the above Act not more than $2\frac{1}{2}$ grains of ammonia are allowed to 100 cubic feet. For carbonic acid pass a jet of gas through a solution of lime and water which has been allowed to settle; the acid will cause a white discoloration. No sulphuretted hydrogen is allowed under the Act. The test is to prepare a piece of paper with acetate of lead and to put it into a jet; sulphuretted hydrogen will turn it brown.

Pipes of wrought iron, with screwed joints should be used. Lead and composite pipes, are to be avoided, owing to their

liability to injury, and to the fact that nails are often found to have pierced them during the finishing of a building.

Messrs. Stott publish the following formula to ascertain the sizes of pipes required, the specific gravity of London gas being assumed to be constant, and the pressure being taken at $\frac{7}{10}$ in. :—

$$N = \frac{200 D^2 \times \sqrt[4]{D}}{\sqrt{2 \times L}}$$

Where N = the number of lights, each consuming 6 cubic feet per hour.

D = the internal diameter of the pipe in inches.

L = the length of pipe in yards.

Molesworth gives the following table of the inside diameter in inches of service pipes :—

No. of lights burning 5 c. ft. per hour.	Distance from main in feet.						
	25	50	75	100	150	200	300
5	$\frac{3}{8}$	$\frac{3}{8}$	$\frac{3}{8}$	$\frac{3}{8}$	$\frac{1}{2}$	$\frac{1}{2}$	$\frac{1}{2}$
10	$\frac{3}{8}$	$\frac{1}{2}$	$\frac{1}{2}$	$\frac{1}{2}$	$\frac{5}{8}$	$\frac{5}{8}$	$\frac{5}{8}$
25	—	$\frac{3}{4}$	$\frac{3}{4}$	$\frac{3}{4}$	$\frac{3}{4}$	$\frac{7}{8}$	$\frac{7}{8}$
50	—	—	$\frac{7}{8}$	1	1	$1\frac{1}{8}$	$1\frac{1}{4}$
100	—	—	$1\frac{1}{8}$	$1\frac{1}{4}$	$1\frac{3}{8}$	$1\frac{3}{8}$	$1\frac{1}{2}$

It is convenient to have a small draw-off pipe at the lowest point of the service, so that the water absorbed by the gas in the reservoir (where it is stored over water) and deposited in the pipes may be drawn off. Gas readily absorbs water and deposits the same when at a lower temperature, and where water meters are used the deposit of this water in the pipes is a great nuisance, as it produces a flicker in the lighted gas which renders it impossible for convenient use.

Governors.—The pressure of gas is measured by the height of a column of water that it will support, stated at

tenths of an inch. It is desirable to keep the pressure constant, so as to ensure uniformity in burning; any excess of pressure produces waste, and it is generally conceded that for ordinary burners seven-tenths is the best pressure. Gas is supplied to the consumer at pressures varying from 1 in. to nearly 4 in., and hence it is always advisable for the householders to have a **governor** to maintain an equal

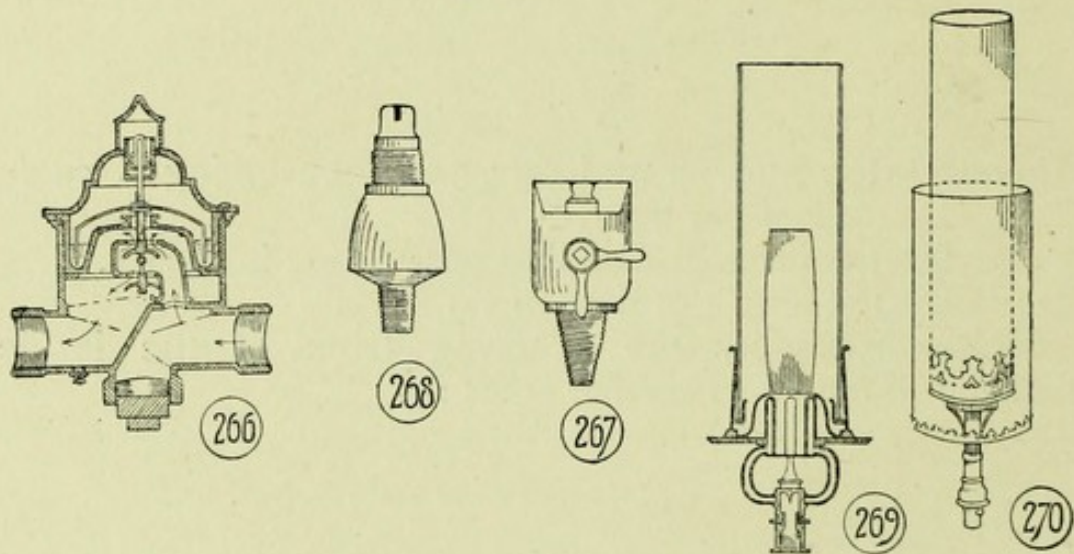

pressure irrespective of the Gas Company. Fig. 266 is a section taken through a Stott governor fixed to a service pipe or meter. It closes with an increase of pressure from the mains, and opens with a decrease; as jets are turned out, so much gas is shut off from the meter, and *vice versa*. The practice that some householders adopt of turning off the gas at the meter every night is not to be commended, because very often the taps to some of the fittings are left open, and consequently when the supply is turned on again the gas escapes from such fittings, and an accident is probable.

Burners.—The two burners mostly in use for ordinary domestic purpose are the "fish-tail" and the "bat-wing," which are shown in figs. 267 and 268 respectively. The "fish-tail" has a circular depressed top, from which two jets of gas are inclined to each other, and as they impinge upon themselves a broad but thin sheet of flame is produced. The "bat-wing" has a semi-circular bulb with a fine vertical slit from which issues a flat, semi-circular flame.

There are many forms of the "argand" burner, a section of one being shown in fig. 269. The "mantleless incandescent" is a form of argand, but has two chimneys (see fig. 270); the air supply to the burner being brought down between the inner and the outer glass is thus warmed, and more perfect combustion is obtained. This company claim that their burner gives a candle power of 33.40, as against 16.0 of the London Argand and 9.15 of the ordinary flat flame, all three consuming 5 cubic feet of gas per hour.

The *Welsbach Incandescent Gaslight Company* created quite a revolution in lighting by their mantles, which are placed over a Bunsen burner; the only cause that prevents their more extensive use is the fragility of these mantles. If placed in positions to avoid draughts, and where there is small risk of vibration, the mantles may last six months; but in unfavourable positions they have been known to fail after a few hours. The mantle is manufactured by soaking an ordinary cotton netted hood in a solution of thoria and cevia. It is then dried and ignited, thus leaving only the metallic oxides; the mantle is then dipped in collodion, which renders it less brittle to handle. The collodion is burnt away when the mantle is placed on the burner, and the brittle network of oxides is left. Just recently, however, the Welsbach Company have introduced a new anti-vibration spring attachment, as shown in fig. 271, to be used where the burners are subject to shock and vibration, and this seems to be successful to a large extent. A new burner has also been introduced which obviates the use of a chimney.

Messrs. Siemens invented the regenerative burner by which the air and gas are heated previously to their junction; the apparatus is, however, costly and not much in use. Messrs, W. Sugg & Company are the agents for the *Somzée-Greyson Intensified Gaslight Company*, whose system consists of using gas under a higher pressure with an incandescent mantle; the installation is, however, rather

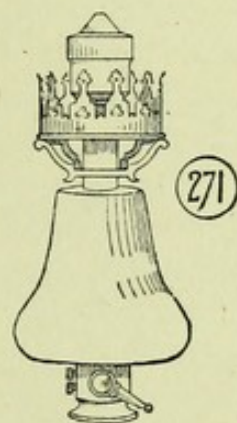

expensive. Fig. 272 shows a method of extract ventilation with a **sunlight** containing many burners on a ring, and drawing out the heated vitiated air as it rises to the top of the room.

Acetylene.—This gas is made by adding water to calcium carbide and is now being used to some extent, the generating plant required being somewhat simple. It is much more powerful than coal-gas and does not evolve carbonic oxide. The plant for 100 lights costs between £60 and £100, and it will, no doubt, be much used where the electric current is not obtainable. Experiments with this form of lighting will be watched with much interest ; at

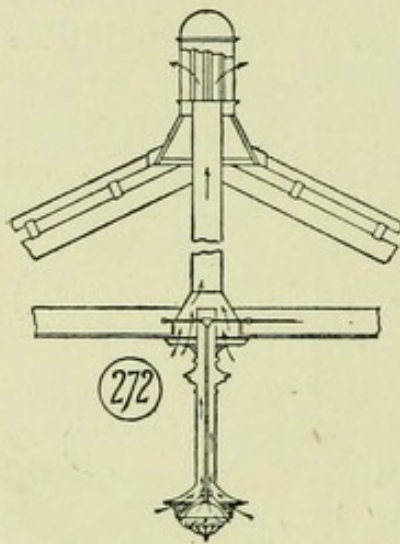

present the clogging of the burners and the disagreeable smell are two great disadvantages.

The Electric Light possesses many advantages over other illuminants, the more important being that there is no combustion, as with gas, to consume the oxygen in the air. It gives a steady light, it is easily switched on and off without striking matches ; decorations are preserved and remain clean for a longer period, and it can be put in positions where gas

would cause a conflagration. The definitions of the following terms which often occur may be found of use :—

An *ampère* is the unit of quantity.

A *volt* is the unit of pressure.

A *watt* is an ampère multiplied by a volt.

An *ohm* is the unit of electrical resistance.

An *electrical horse-power* is equal to 746 watts, thus a current of 7.46 ampères at 100 volts pressure is equal to one Board of Trade unit.

A Board of Trade *unit* is the standard measure of output, and this consists of 1,000 watt-hours. Thus, 10 ampères of current at 100 volts pressure for one hour is equal to one Board of Trade unit.

Production.—Where it is possible to obtain current

from a public supply station it is usually more economical to do so than to manufacture it for oneself. The Supply Company manufacture the current by means of a **Dynamo** in which rings of copper wire pass rapidly before the poles of powerful electro magnets. These rings of copper are wound on an iron core, and the whole is called an **armature**. The currents thus generated in the rings are led to a **commutator**, from which they are collected by brushes and taken away to the switchboard, and from thence to the supply mains. Currents are often generated at a very high pressure, so that the size of the copper cables may be kept as small as possible; the lower the pressure the larger must be the number of ampères, which, of course, require a larger cable. This high-pressure current, however, must not be delivered in this state; it is, of course, most dangerous to human life, therefore a **transformer** is used, which converts a small current of high pressure into a larger current at a lower pressure. Thus 40 ampères at 2,000 volts could be transformed into 800 ampères at 100 volts, both being equal to 80,000 watts. These transformers are usually placed in suitable positions for the distribution of low pressure to the house mains. Dynamos are usually driven by steam engines when a large supply of current is required, dust refuse mixed with coal being sometimes used as fuel. Gas and oil engines are often used for small supplies. Where water-power can be obtained turbines should be used; they consist of vanes fitted to a wheel, which latter is made to revolve by the water impinging against the vanes. Where the water-power is small, storage batteries should be used, so that the dynamo can be worked continuously, and when lighting is required both dynamo and battery can supply the current. **Storage batteries** consist of a number of cells containing sulphuric acid, water, and lead plates. When the current is turned on a chemical change takes place until the battery is full; this will be indicated by bubbles of hydrogen gas rising in the fluid. When the battery is discharged on to the mains an exact reversal takes place and the current is given off. Batteries should be placed on racks, separated from the engine-room, as the gas they give off corrodes the machinery.

They should also be used regularly, as they deteriorate if not worked. If well looked after, the deterioration should not exceed five per cent. per annum.

Wiring.—Two (or more) copper wires convey the current in any installation, one wire (the positive) conveying the outward current, and another the returning current (the negative) to the source of supply. These wires must be insulated for the whole of their distance, and this is accomplished by covering them with an insulating coating, such as vulcanised rubber; and the higher the pressure employed the thicker and more complete must be the covering. In fixing these insulated wires in houses, &c., many methods are in use:—

- (a) *Wooden casing.*
- (b) *Concentric wiring.*
- (c) *Steel armoured insulating conduits.*

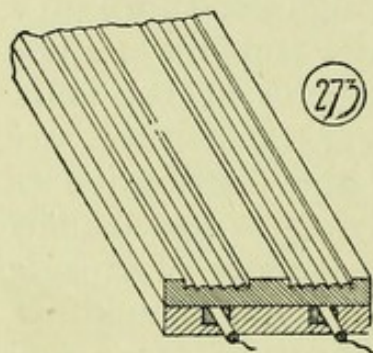

(a) This is the most common method, namely, to enclose them in a wooden casing as shown in fig. 273, which is either run along the external face of the plaster or is buried in the work; the latter is very objectionable on account of the difficulty of getting at any defect. The wood casing should always be

covered with a solution of shellac to prevent dampness destroying the effectiveness of the installation. Wood casing should never be used where it can be avoided, and in Germany it is now prohibited, and for cheap work preference is now given to insulated conductors, which are run in sight, side by side, upon porcelain knobs. If immunity from disturbance can be assured, and if the wires are not concealed, this practice is satisfactory.

(b) In the better work **concentric wiring** is used. This consists of the positive copper wire being insulated with rubber or other material, and the negative wire being wound concentrically round such insulation, and the whole being enveloped in lead. An extra sheathing of steel wires may be used outside the lead envelope. In concentric wiring the negative conductor must be run to earth.

(c) There is no doubt, however, that the wires should, where possible, be run in a steel armoured insulating conduit. Iron piping has been extensively used, but, owing to the disastrous effects of short circuits thereon, and owing to the abrasion of the insulating surface from the wires, caused by the jagged nature of the jointing, and also owing to the liability of condensation therein, it is found that some insulating material should be coated on the inside of the pipe itself. The difference between a section of ordinary iron piping and a section of steel armoured insulating conduit is shown in figs. 274 and 275.

A **double pole** switch should be used at the point where the supply enters the house ; this will allow of the negative and positive conductors being cut off from the main. A double pole fuse should be placed by this switch and on every branch service throughout the building. A fuse consists of a piece of lead or tin

wire, so that if a greater current is passing along than the wire ought to carry, this fuse will melt and stop the supply. Any number of switches may be used in an installation, so that the light

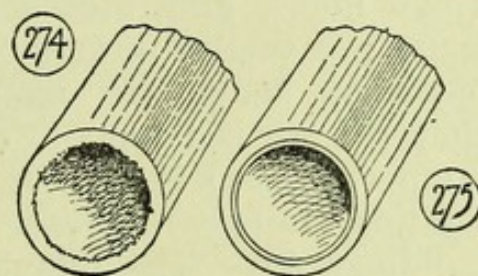

may be turned on and off as may be most convenient, and switches may also be placed on the fittings themselves. A switch should always be placed just inside or outside a room, so that a light may be obtained without groping about.

Fittings.—An endless variety of fittings of all descriptions for the incandescent light are now upon the market, from the flexible pendant (fig. 276) to the most costly and elaborate designs. The adjustable flexible pendant (see fig. 277) is a convenient form, and is much in use where a plain fitting is required. More elaborate fittings are shown in figs. 278, 279, 280, 281, and 282, the latter figure being a three-light burner fixed to the newel of a stair. In all sitting and reception rooms it is well to have a number of wall plugs, which are simply terminations to branch circuits from which current can be obtained, so that lamps may be

moved to different positions in the rooms. They also allow of effective decorative lighting for receptions, and may also be used for electric radiators. An effective scheme of illuminating a dinner table is to immerse the lamps in a table fountain.

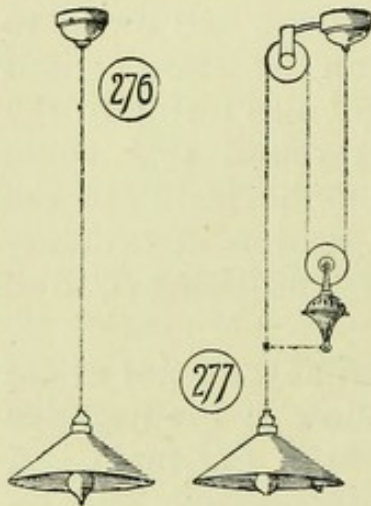

Lavatories and water-closets may be lighted so that the switches are automatically turned on and off by the opening and shutting of the doors. Special water-tight fittings are sometimes used in stables to prevent the fumes arising therefrom corroding the metal parts of the lampholders. An ordinary incan-

descent lamp will last about 1,000 hours, and uses about $2\frac{1}{2}$ watts per candle power. Higher efficiency lamps are made, but they do not last long. The *arc* lamp (fig. 283) is used for street lighting, railway stations, public buildings, &c. The illumination is caused by the current leaping the space between two carbon pencils, which latter

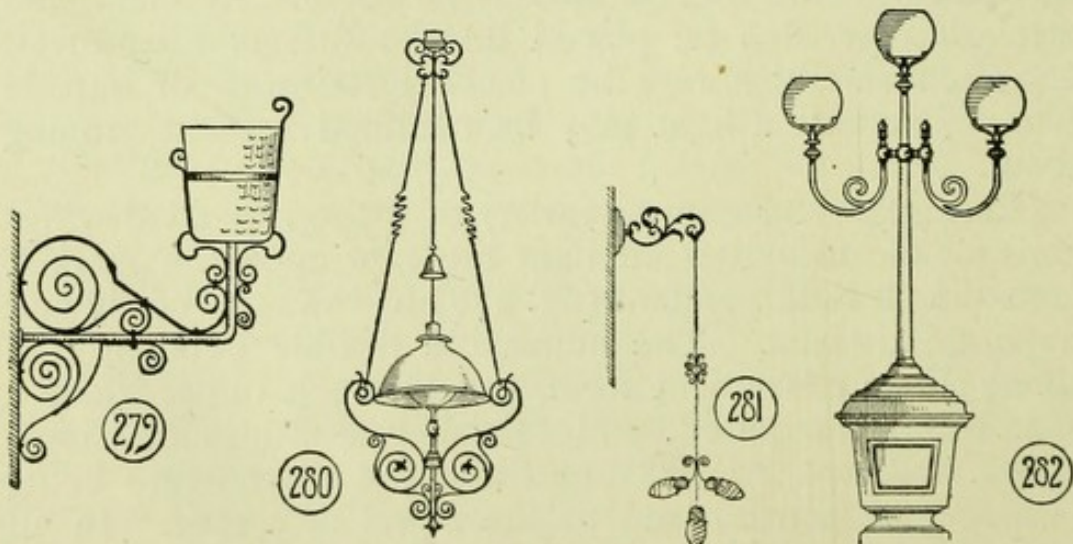
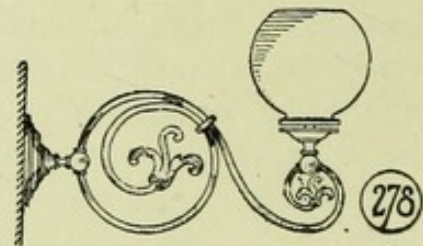

automatically approach each other as they are consumed. The carbons have to be renewed about every 100 hours.

These lamps are made from 500-candle power upwards, and their illuminating power is greater for the amount of current consumed than the incandescent. Technical Institutes sometimes have their studios and drawing offices lighted by illuminating the ceilings with the inverted arc lights, the reflected light thus obtained being very pleasant to work by, and all shadows are avoided.

Cost.—Electricity at 6d. per unit is roughly calculated to be equivalent to gas at slightly over 4s. per 1,000 cubic feet, assuming 4 watts per candle power. But it must be remembered that the electric light is more economical owing to the facility of switching it on and off, and also that gas is often left partially turned on to save the trouble of relighting. There is also a saving in the decorator's bill; books, pictures and curtains are better preserved, and the health of the occupants is more easily maintained. When it was introduced into the General Post Office in lieu of gas, £800 was saved during the first year in employees' overtime, owing, so it was said, to the fact that more work could be done in the same time in the healthier atmosphere, and the sick list was also reduced by it.

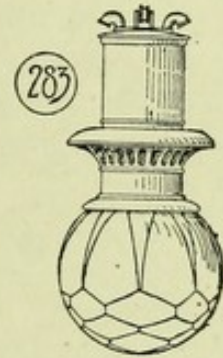

The usual charges by the present day supply companies are 6d. per unit during the dark hours, and 3d. to 4d. per unit during the day time. This is done to encourage the use of electricity when the greater portion of the machinery would otherwise be idle. The Brighton Corporation charge 7d. per unit till a certain standard has been used, and then only 1½d. per unit is charged. The Westminster Electric Supply Corporation charge 6d. per unit with rebates of from 1 to 16 per cent. after a certain quantity has been used; 4d. per unit is charged for motors. In Edinburgh the cost of production is only just over 1d. per unit, and 4d. is the maximum and 3d. the minimum charged to the consumers for lighting purposes.

The cost of running the wires in casings as described previously must, of course, depend upon the different situation and circumstances of each case, but for anything over fifty

lights, £1 per light should cover everything except the fittings.

For country houses with between two and three hundred lamps the cost of supply ought not to exceed £120 per annum where the dynamo is worked by a steam engine; the whole cost of the attendant should not be put down to the engine, as it should not take up more than half of his time. The cost of the installation and plant varies so considerably with the circumstances of each case that not even a rough estimate can be given for this.

CHAPTER XVII.

SANITARY INSPECTION.

THIS is one of the most important duties that falls to the lot of the professional man and one that is usually underrated. And yet the health and even the lives of one's clients depend upon the care and skill exercised in the practical branch of hygiene.

In making a report upon a particular house or property a system should be adopted, so as to obviate the omission of important points that may be of vital interest to one's clients. We will, therefore, discuss these points in the following order :—

1. *Nature of Site and Soil.*
2. *Description of House and Aspect.*
3. *Nature of Materials Used.*
4. *Means of Heating and Ventilation.*
5. *Water Supply.*
6. *Sewerage and Drainage.*
7. *Plumbing and Fittings.*
8. *Lighting.*
9. *Method of Disposal of Refuse.*
10. *Alterations, Improvements, and Repairs.*

1. Nature of Site and Soil.

This has been discussed in Chapter III., and we need only refer our readers to that chapter. A few trial holes may be dug to find out the character of the soil, if any doubts exist.

2. Description of House and Aspect.

It is advisable to make a rough sketch-plan to a small scale, and to show thereon the points of the compass, so

that the aspect and approximate size of the principal rooms, on the ground floor at least, may be readily discernible. Of course, the number of stories, and the number and the nature and size of the rooms in each, should be set out. The nature of the adjoining property should be also briefly noted.

3. Nature of the Materials used.

This should be stated, and the condition and approximate age of the same should be mentioned as also their effectiveness. Particular notice should be taken of their suitability for resisting the weather and dampness.

A note should be made as to the material forming the damp-course, and its height above the ground level. In the case of basements it should be ascertained if there is a vertical damp course or dry area to keep off the water from the fabric. The internal face of such walls should be examined to see if there are any signs of dampness.

The floors should be examined to see if they are sound and not affected by dry rot; it should also be ascertained as to whether they are efficiently ventilated with air bricks, &c.

The roof should be examined and the nature of the external covering should be reported, and also as to whether felt or Willesden paper has been used between such covering and the boarding.

4. Means of Heating and Ventilation.

These should be described, and their efficiency should be tested if possible. The relation of the superficial area of window opening to the floor space may also be usefully noticed. The proximity of high buildings, &c., often affects the efficiency of the chimney flues. Fixed cowls are usually found to be more effective in curing this nuisance than revolving ones, and they have also the advantage of being less noisy.

5. Water Supply.

The source should be reported, and also the nature of the pipes and fittings and their suitability for the character of the water supplied. If supplied by a water company it

should be ascertained as to whether the supply is constant or intermittent. If from a well or other source an examination should be made to see if there is any cause of pollution, and the structure of such well or other source should be examined.

The nature and sufficiency of the means of storage should be noted, and also the suitability of the nature of the materials used in such storage.

The filters should be examined and reported upon, and also as to whether they are supplied direct from the main supply pipe.

The information given in Chapters XI. and XII. should be consulted.

6. Sewerage and Drainage.

The method of the collection and disposal of the sewage should be ascertained. If this is accomplished by the Local Authority, the efficiency of the treatment and the nature thereof should be investigated. If the sewage has to be treated by the householder, a careful inspection should be made, and consideration of the system in use, and the practical working of the same must be carefully examined. A note must also be made as to the proximity of the water-supply and its liability to pollution from this cause.

The course of the **drains** should be traced and noted on the sketch plan, and the sufficiency of their fall and their ratio to the lengths of piping used should be marked thereon. The sizes of the various drains should be written on the plan; and it must be seen that the drains are effectively disconnected from the sewer by a proper intercepting trap.

The nature of the drain-pipes and their jointing must be ascertained, and also as to whether they are laid on a bed of concrete (and its depth) or whether imbedded in the same. The existence and efficiency of traps must be reported upon, as must also the proper inlet and outlet ventilation of the whole system. The means of access should be shown on the plan and the efficiency of the whole system must be tested.

The following are the tests that may be applied :—

- | | |
|---------------------------|----------------------|
| <i>a. Olfactory test.</i> | <i>d. Mirror.</i> |
| <i>b. Smoke test.</i> | <i>e. Pneumatic.</i> |
| <i>c. Hydraulic test.</i> | |

(*a.*) The **olfactory** test is much used in testing existing drainage. It should be applied as follows :—

A tablespoonful of crude oil of peppermint or other chemical with a pungent odour should be placed in the highest water-closet, and a bucket of very hot water should be used to wash it through the trap. The assistant doing this part of the work should lock himself in and put a damp cloth at the bottom of the door, so as to avoid all risk of the smell penetrating into the rest of the house. He should remain therein until the test is complete, otherwise

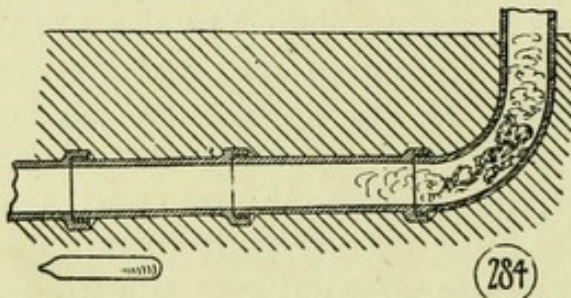

284

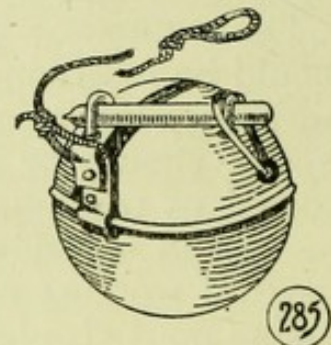

285

he may carry the smell about the premises. If the smell makes itself evident in the house or along the course of the drain outside, it, of course, indicates a defect in the drainage, which may be roughly traced to its source. All ventilating shafts, pipes, inlets, &c., should be closed by means of a damp cloth or clay. This test may also be repeated in the lower water-closets, so as to further test the traps, pipes, and fittings. A gully outside the premises may also be used to test the earthenware drains.

The **Banner** drain grenade or ferret is often used instead of the essential oils for the olfactory test. Fig. 284 shows this useful appliance. It is manufactured of thin glass, and is charged with pungent and volatile chemicals. It breaks on being dropped into the trap, and there is consequently less risk of an ineffective test, as but little or no smell

should be felt in the apartment if the grenade is well washed through the pipe.

Another method of using this grenade is shown in fig. 285. A grenade is placed under the staples, which is then made secure by stretching the rubber band over the grenade beyond the first staple.

When the line is jerked it will release a lever and bring it in contact with the grenade, which will be broken to pieces.

(b.) The **smoke** test is very often found to be the most convenient to use, and, since the introduction of smoke machines, it is considered by some to be a very fair test for drains that have not been recently laid. The simplest form of smoke test is accomplished by the **rocket**, which is illustrated in fig. 286, and it will be seen that it consists of

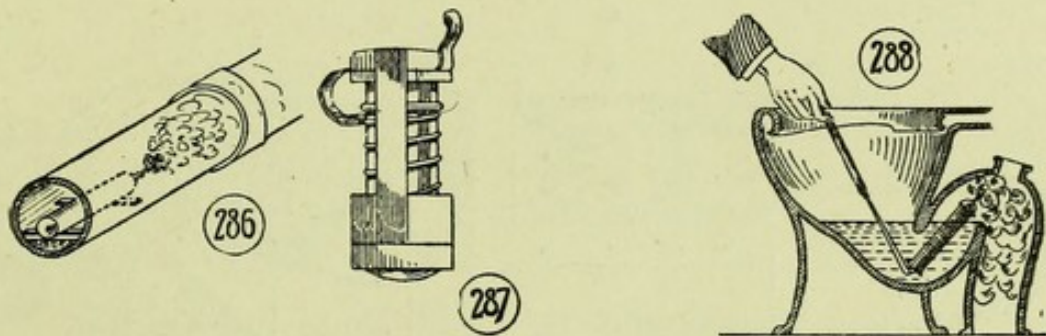

a cylinder about 7 in. long by 2 in. in diameter, with a fuse at one end. When the latter is ignited a dense volume of smoke with a pungent odour is emitted and forced up the drain. Great care must be taken in applying the rocket in the manhole, as we have often seen men rendered unconscious through the fumes of the smoke. The strips of wood shown on the case are turned at right angles to it, and keep it off the invert of the pipe.

Fig. 287 shows a useful little invention. It is **Kemp's Patent Drain Tester**. The cover is removed and the tester is lowered into the water-closet trap on a string, which should be secured. Hot water is then thrown down the fitting so as to wash the appliance into the drain. A strong odour and a large volume of smoke is the result, and defects can be readily detected thereby. The tester should be

pulled up on the string, after the experiment, and examined to see that the contents have been discharged.

Burnett & Groom's Tester is shown in fig. 288. The trap should be flushed, and then the tester should be ignited and passed through the water by means of the loose handle, and should be left there for about ten minutes. The drain is thus charged with a dense and pungent smoke.

Of the **Smoke Machines**, fig. 289 represents the "Eclipse Smoke Generator" of Messrs. Burn & Baillie. It is composed (B) of a double-acted bellows covered with prepared leather and a copper cylinder (C), which constitutes the fire-box. The latter is surrounded with a water-jacket. A copper "float" is placed over the cylinder, and an air-tight joint is thus formed. A specially-prepared india-rubber tube, made to withstand the heat, is connected

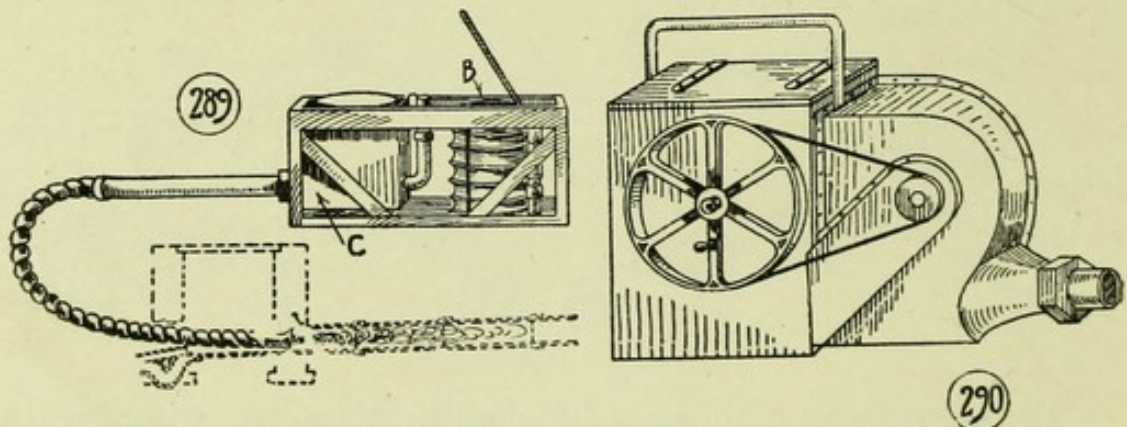

with the outlet of the machine. By working the bellows the smoke is forced into the drain, all openings, such as ventilation-pipes, being, of course, plugged. The smoke is generated by burning "touch paper" or cotton waste, &c.

Fig. 290 shows the **Tyndale Asphyxiator**, which is compact and convenient, and possesses the advantage of not having any small parts likely to get lost.

A simple smoke machine called the "Asphyxiator" is shown in fig. 291.

The smoke is obtained by lighting sulphur, tar-paper, &c., in the bucket, which is provided with a cover, and by turning the wheels a fan is set in rapid motion causing the smoke to be driven into the drain by an india-rubber tubing.

Another form of smoke machine is shown in fig. 292.

To test the drain you must remove the water seal from the trap, insert the hose piece A through a piece of board B, and make tight the joints with clay; a smoke cartridge is then placed in the cylinder C, and by lighting the end of

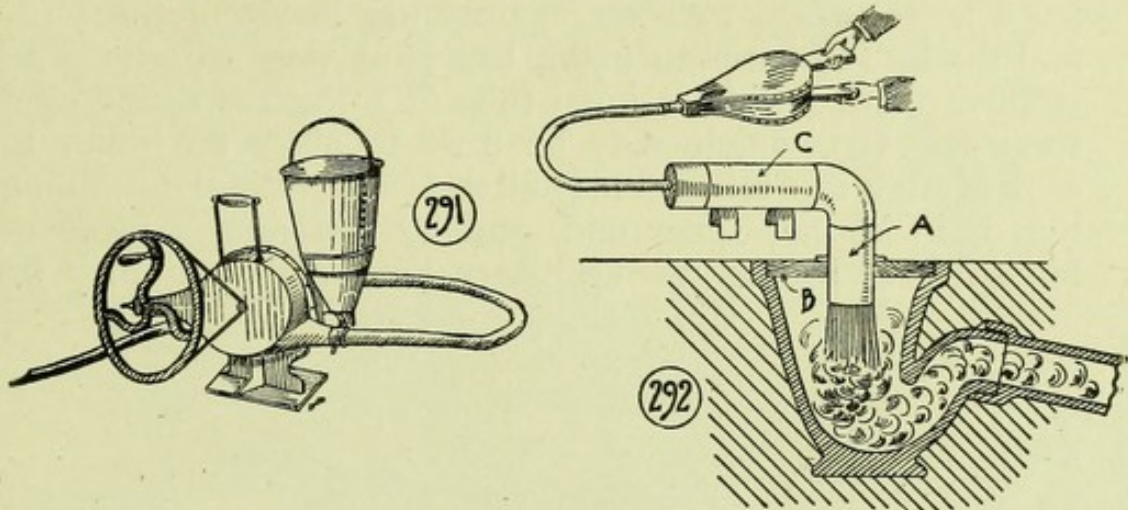

the cartridge and blowing gently with the bellows a dense volume of smoke is ejected into the drain.

Fig. 293 illustrates a probing iron, which is used along the course of the drain being tested by the olfactory or

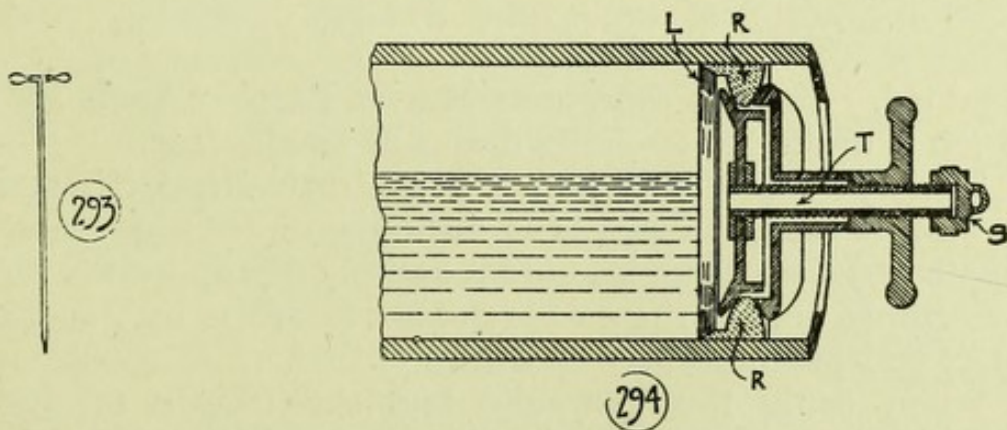

smoke tests, which assists the smell or smoke to make itself apparent.

(c.) The **Hydraulic Test** should invariably be insisted upon for all new drains, and, of course, no drain can be said to be in a really safe and satisfactory condition unless it is capable of withstanding this test.

The lower end of the length of drain-pipe to be tested should be plugged. This may be accomplished by means of a drain-plug or bag.

Fig. 294 shows a section of the **Addison Patent Plug**, which is a very convenient form. The rubber ring (RR) has a large surface to press against the inside of the pipe, and the lip (L) tends to make the joint very secure. The stopper is fitted with an inner tube (T) which is sealed by a screw-cap (S), which may be used to allow the water to escape after the test. This latter is also useful for filling the drain at the upper end, and by attaching a piece of india-rubber tubing the necessary head of water may be

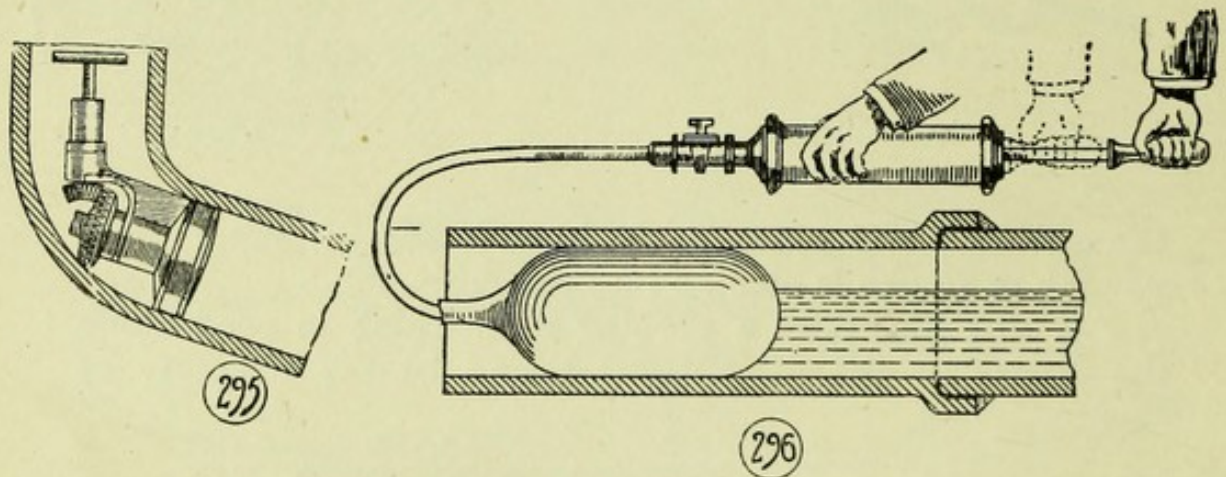

obtained. Fig. 295 represents Messrs. Burn's "Angle Plug," which is useful for stopping drains at bends, &c.

Fig. 296 represents **Jones's Patent Pipe Stopper**. As will be seen, it consists of an india-rubber bag which is inflated by a small pump, until it entirely fills up the aperture. By turning the tap the air is released from the bag, and the latter collapses and may be drawn out.

When using the hydraulic test the lengths of drains should be tested between the various manholes; but where no such conveniences exist of course the drain must be taken up at various points, and plugged as previously described. The level of the water must be carefully noted, and any subsidence, after a period of two or three hours, indicates that there must be a defect somewhere in the length of pipe tested, or it may be that *tested* drain pipes

have not been used, and that water exudes through the pores of the pipes.

(d.) The **mirror test** is very useful for discovering sagged joints, &c., and localising them. Fig. 297 illustrates its application; a lighted candle is placed at one end of the drain in the inspection chamber, and the mirror is placed at an angle at the other. By standing over the mirror the interior

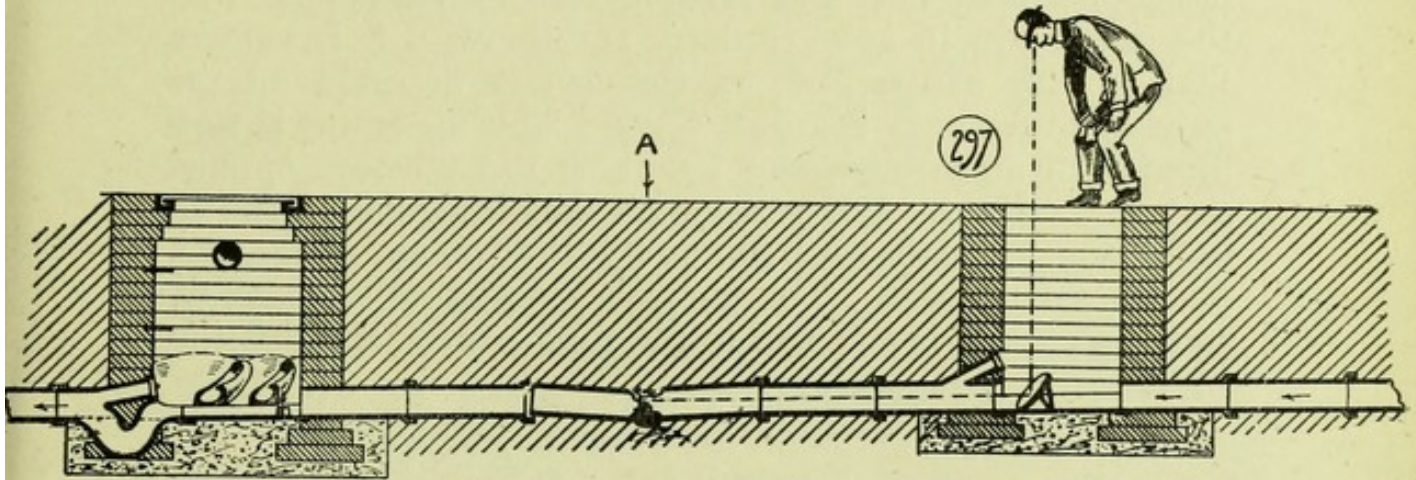

of the pipe is viewed, and any defect may be noted, and the number of the defective joint from either end should be written down in the note-book. In the example shown it will be noticed that two drain pipes have sagged, and in consequence have forced off the collar and spigot end of the pipe. This would be written in the note-book as the third and fourth drain pipe, and the earth would be excavated at A. The damage was evidently caused by no bed of concrete being placed under the pipes. It will be noticed that the sewage has oozed through the defective pipes and polluted the soil. **Doughty's Inspection Lantern** is shown in fig. 298, and it consists of a small carriage to which is attached an electric lamp. An automatic reflector is used in connection therewith, and any irregularities in the drain may thus be detected. This instrument can be used for drains that are not in a straight line from point to point.

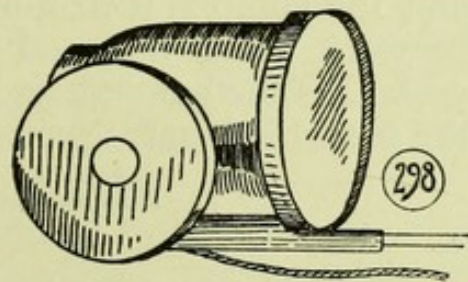

(e.) The **pneumatic test** is now advocated by many, but it is not frequently used in practice. It consists of pumping air into the drains and their connections by means of a pump or other mechanism. It may be applied by means of the **Eclipse Smoke Generator** shown in fig. 289. All openings to the drain must, of course, be plugged up, and then the bellows are put in motion. If after a few strokes the copper float rises and remains stationary it is clear that the drains are in good order. If otherwise it is evident that a leak exists, and its seriousness depends on the rapidity with which the float sinks. This apparatus is now fitted with an arrangement by which the pressure applied may be regulated. The **Jensen** pneumatic machine is shown in fig. 299. F is the force pump, P is the pressure gauge, and S is the safety valve. The pump is screwed on the cock C, and the cock T is attached to the tube passing through the

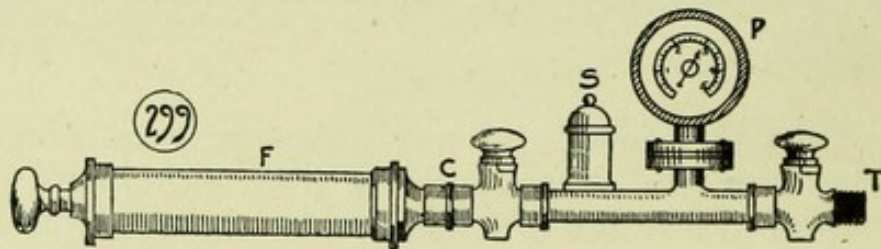

plug or bag. The safety valve is set at the pressure required and the pump is then worked, any excess over the required pressure being liberated through the safety valve. The cock C is then closed, and any leakage will be apparent on the pressure gauge.

7. Plumbing and Fittings.

We have discussed the construction and ventilation of plumbing and fittings in Chapters VII. and VIII. The importance of the careful examination of these can scarcely be over-estimated. In the first place, see if all fittings are efficiently trapped, whether anti-siphonage pipes have been used, and whether they are carried up above the topmost fitting in the down pipe. Note whether the pipes are in such positions as to be liable to be affected by frost. See that

the soil pipe at the highest point from the sewer is carried up well above the roof and away from all window openings, &c.

The plumbing and connections of fittings may be tested by the olfactory or smoke test, as before described. The hydraulic test is generally considered to be unfairly severe, more especially if the pipes are of any great height, as, of course, the pressure is very great.

The fittings should be examined to see that they are effective. As a rule, the simpler they are the more efficient is their action. A good means of testing the self-cleansing properties of an apparatus is to cover the inside with lamp-black, a few pieces of paper being dropped on to it in different places, the removal of which on flushing can be readily observed. When the fitting is flushed, the basin should be left perfectly clean.

Some of the water companies refuse to allow water-waste preventers of a greater capacity than two gallons to be used. In these cases we have found that a notice conspicuously placed near the fitting requesting the user to flush both **before** and after using conduces to the cleanliness of the fitting and the adjoining pipes. It has also been known to cause the water companies to consider whether it would not be more economical to have a three-gallon flush instead of the twofold two-gallon discharge.

Be certain that the smoke **does** come out of the top of the soil pipe, more especially if the latter be of iron, as we have often found that the interior is blocked up with oxide of iron. It may also have a sag or other defect which contains sufficient liquid to prevent the flush efficiently performing its work.

8. Lighting.

If gas is the lighting medium, it is well to employ a **gas escape detector**, such as is made by Messrs. James Stott & Co. This is a governor attached to the gas service near the meter, to use as a detector. The taps should all be turned off. The main cock is then turned on, and the movement of the brass spindle is observed. When the spindle has risen the main cock is turned off. If the spindle remains in position it indicates that the work is in

a satisfactory condition ; if, however, it falls there must be a leak somewhere in the system. The detector also acts as a pressure regulator, and it is claimed that from 10 to 40 per cent. is saved in the consumption of the gas.

If **electricity** is the source of lighting, make a note as to the means employed of conducting the current. Of course, the best means is that of the armoured conduit mentioned in Chapter XVI. The wiring should also be tested to see if there is any leakage.

9. Method of Disposal of Refuse.

This should be mentioned in your report, with a note as to who collects the refuse and how often this occurs. The means of storage should be noted, and also the suitability of the construction of such receptacle. Also examine the kitchen range to see whether a firebox is provided to burn the garbage and vegetable matter.

10. Alterations, Improvements, and Repairs.

This portion of the report should give an epitome of the work required to be done. The same method should be observed as in the inspection itself, so that both portions of the report may be readily compared by looking at the distinctive numbers of each subdivision. An estimate of the cost may also be added. We now give two examples to illustrate the methods that we have enunciated.

CHAPTER XVIII.

SURVEYS AND REPORTS.

WE give here an imaginary Report, as an example that may be useful. Of course every case will have its own peculiarities, which must be carefully studied, but perhaps the following may serve as a useful guide, and may act as a reminder of points that might otherwise perhaps be overlooked.

The Report is supposed to refer to a **country house** which is to be altered and improved:—

Sir,—In accordance with your instructions of the
and your letter of the we have surveyed
the above property with the object of advising you as to its
general condition from a structural and sanitary point of
view.

I. THE HOUSE.

The house is situated in the parish of ———, and on the high road between Hickey and Bexbroom, in the county of Downshire. It is therefore comparatively easy of access by road, but it is some three miles from the nearest railway station, which being on the London and Wreckham Railway has a very poor service of trains. It is some 600 ft. above the sea level, and is built upon a sandy soil, and is considered to be very healthy, and well adapted for the purpose you require. The death-rate for the locality is returned as averaging only 18 per 1,000. The rainfall is estimated at 32 in. per annum.

With regard to the general plan and convenience of the house and its structural condition there are several points

upon which we should like to draw your attention. We will take these seriatim, making the drains and sanitary work the subject of a separate report. We enclose a plan of the house as at present with suggested alterations marked thereon (fig. 300).

The house appears to have been built about the end of the seventeenth century, and to have been very little altered since that time. It contains a fairly large hall, drawing-room, library, dining-room, morning-room, water-closet under stairs and entered directly from hall, butler's pantry, kitchen, scullery, and the usual offices.

The library is at present a thoroughfare room leading to the drawing-room; this is, of course, very inconvenient. We would suggest that a wall be placed across the northern end of the room, and a passage thus formed which will give privacy to the library. This room is also quite insufficiently lighted for its purpose. We would suggest that the present window be made into a doorway, and that a window 2 ft. wide be opened out on either side, which will greatly improve the room. The living rooms are all rightly placed on the south side of the house, but the sun's glare would perhaps be rather much for the library, and we would therefore suggest, in order to make the drawing and dining-rooms more convenient, that bay windows be placed as shown, and that the roof should be continued between the two so as to form a covered verandah. The entrance is on the north, and in order to protect the house from the cold north winds which blow across the rather damp meadow land in this direction, we would suggest that a second set of glazed doors be placed as shown, and that a *porte-cochère* be added. The hall is also somewhat gloomy, and windows should be inserted on either side of the entrance door.

At present the service to the dining-room is along the staircase and across the front hall; this is, of course, very objectionable. We would suggest that a service hatch be placed as indicated, so that the front hall need not be entered. This is, of course, not an ideal arrangement, but it will, we think, answer satisfactorily.

Taking next the inner hall, the water-closet, as mentioned previously, is entered directly from this hall. We would

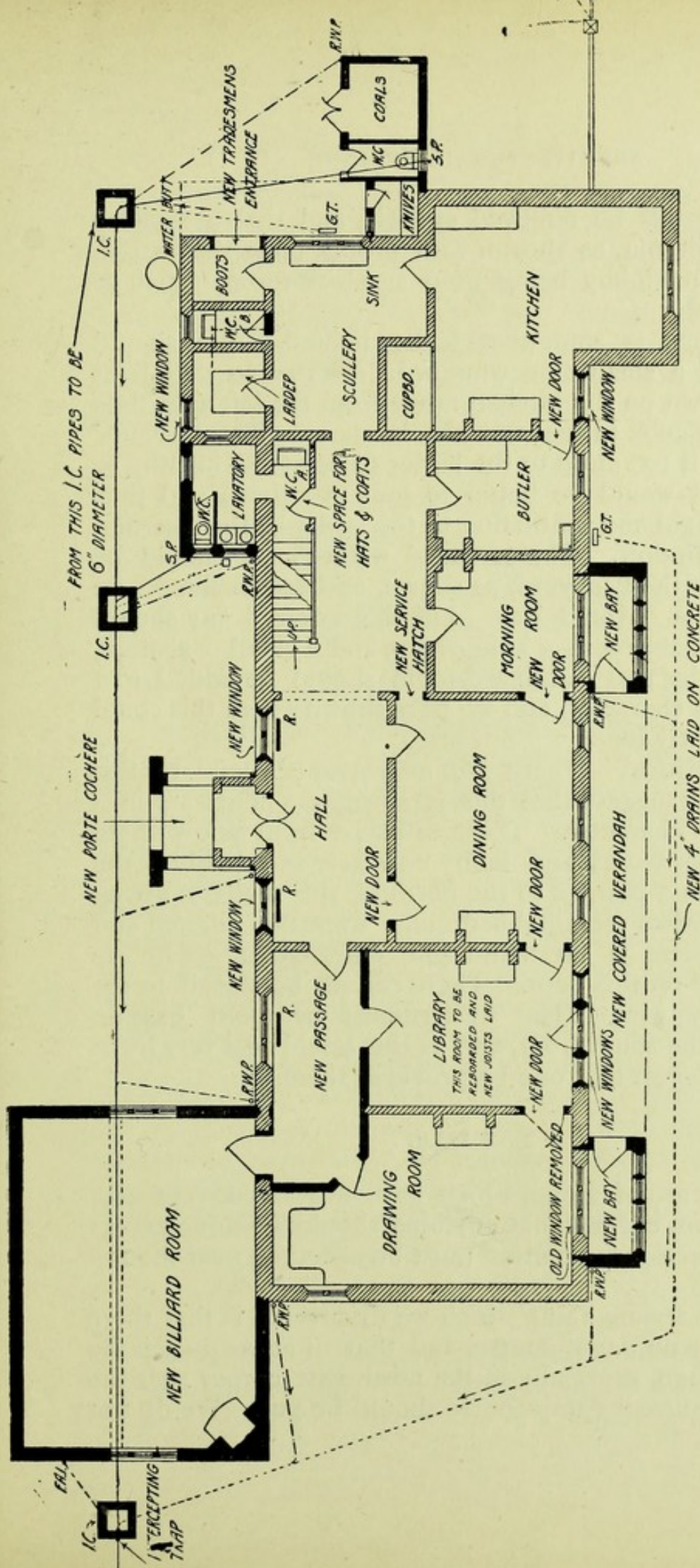

NOTES.

- W.C. marked **A** removed and space used for hats and coats.
- W.C. marked **B** removed for extension of Larder.
- Pipes under Billiard Room to be embedded in Concrete.
- Drain Pipes marked thus indicate Soil.
- do. do. indicate Sink and Lavatory Waste.
- do. do. indicate Rain Water.
- Walls Blackened indicate New Work.

- Walls Hatched indicate Old Work.
- F.A.I. Fresh Air Inlet.
- G.T. Grease Trap.
- I.C. Inspection Chamber.
- R.W.P. Rain Water Pipes.
- S.P. Soil Pipes.

suggest that this be removed entirely, and that a sanitary wing be built out, as shown, with proper cross ventilation, the ventilating lobby being used as cloak-room, which is much required.

The kitchen is somewhat badly lighted. We should suggest that a small side window be inserted so that light may be thrown on the kitchen range from the left side, thus enabling the cook to see what she is about. The servants' water-closet is too close to the larder to be at all healthy or pleasant. It would be better to pull this down and thus give better light and ventilation to the larder by the insertion of a new window. The servants' water-closet should be re-erected in the backyard, as shown, and access should be provided by a covered way. Off this covered way should be placed a boot-room, a knife-room, and a small coal-store.

We consider that a billiard-room should be added to a house of this character, and we have shown where this could be conveniently built.

Upper Floor.—There are no servants' stairs to this floor, and we suggest that this is absolutely necessary in a house of this character. These can start from below where the old water-closet and lobby now are, and land on the upper floor in a passage to the north of the scullery, giving access to the two servants' bedrooms over the kitchen and scullery. There is no bath-room, water-closet, or housemaids' closet on this floor. These can all be placed in the new sanitary wing. The westernmost bedroom has no window on the south front, and as this would cost very little, we would suggest that one be provided there.

2. WALLS.

The walls are of stone, which have weathered very well, and we do not suggest that anything should be done except that some necessary pointing must be executed near the top of the walls.

The most serious thing which we discovered is that there is apparently no damp-course, and that in consequence the damp has risen, especially in the north-east corner near the well. Of course a damp-course should be put. We do not

think that this need be a very expensive matter. We should advise that a perforated stoneware damp-course be inserted all round the house 6 in. above the ground level, and that this should be done in small pieces at a time (say in 2-ft. lengths) so as not to endanger the fabric. In many cases we noticed that the level of the ground had in course of years risen above the level of the floor joists. We would therefore suggest that this be carefully removed so as to be 6 in. below the level of the damp-course, the latter being inserted under the ground floor timbers.

As to the walling generally, this is sound, with the exception of an old crack in the lintel above one of the ground-floor windows, but on examination this does not appear to have extended for some considerable time. We should therefore merely point this up in cement.

3. FLOORS.

The floors, as is to be expected in such an old house, are in many places very dilapidated. The timbers to the ground floor have been attacked by dry-rot through want of sufficient ventilation. In the library this is specially noticeable, as in one place the flooring has completely collapsed. New joists and boarding will have to be fixed here. The joints between the boarding in the other rooms are very wide, and when the underside is ventilated will cause the rooms to be very draughty, besides harbouring dust. We would, therefore, suggest that $\frac{1}{4}$ -in. parquet be laid round the edges of all the sitting-rooms and over the entire hall, and that the central part of each room, over which the carpet will come, should have the joints caulked with beeswax, the cleaning in future to be done with beeswax and turpentine, this being much preferable to washing. The upper floors are comparatively sound, but the edges (for about 2 ft.) of all rooms on the first floor should be stained and varnished, so that central carpets may be laid down.

4. CEILINGS.

The ceilings will require whitewashing throughout. Those to the drawing-room and dining-room are of an ornamental

description of the Adam's type and will require making good in parts and picking out in party colours.

5. WINDOWS.

These are principally casements of iron and filled with leaded lights in small squares. They obstruct the view to a certain extent, but would very much detract from the character of the house if they were removed. We would, however, suggest that one of the lower lights in each room might be replaced with plate glass.

The pointing of the frames will require making good in cement, several of the fastenings will require repair.

6. ROOFS.

We thoroughly explored these with the caretaker, and find the original tiling will in many places require stripping off and new tiles laid. In other cases the oak pins, which were used in fixing them to the laths, have rotted, although the tiles are quite good. Roughly speaking, about one-quarter of the roof will have to be relaid. The flashings and gutters will have to be relaid, though everywhere the lead is comparatively good. The various settlements which have taken place have seriously affected the fall of the gutters. Cement filleting has been employed where the roof meets the gables. This is defective, and should be stripped off, and "lead soakers" used instead.

The chimneystacks are very exposed, and have been partly blown down. They will require carefully reinstating, with new chimney-pots and flaunching in cement and pointing. The woodwork to the trap-door to roof has rotted away, and does not keep out the rain. It will require a new door and lining.

7. DECORATION.

Beyond the whitening to the ceilings already mentioned, the house will want papering throughout, the present paper being entirely stripped and the walls made good. The

ground-floor rooms are mostly panelled, but have been painted white. We find that this is all oak-panelling, and it will be well to consider whether you would prefer the paint being carefully removed so as to leave the original oak visible. All the rest of the woodwork throughout the house will require rubbing down, preparing and painting two good coats of good oil colour.

The ironwork, internal and external, will also require painting.

The mantelpieces are of good design with marble borders, and will merely require painting, pickling, and cleaning.

8. HEATING AND VENTILATION.

As to the fireplaces, many of these are of old and obsolete pattern, with very little heating capacity. We should advise that these be taken out and new ones of the Pridgin Teale or other approved pattern be inserted. Some form of heating apparatus will certainly be required, as the house is in a very exposed position. The passages especially should have radiators of the ventilating type fixed on a low-pressure flow and return apparatus. We should advise, on the ground floor—two in the outer hall, one in the passage leading to drawing-room, and one in the inner hall; and on the first floor, at least four will be required.

There is room for a small boiler-house under the kitchen, which has been used as a beer cellar, a window with open area could be put to this, and a new flue made, or the hot-water supply system might be continued to be worked from the kitchen fireplace, but a new kitchener will be required in place of the antiquated one now in use, so that the opportunity of improving the supply can be taken in hand at the same time.

The ventilation will be materially improved by the suggested alterations.

Lighting. No gas or electric mains are at hand, so that oil and candles are the only illuminants available. The present fittings are of the poorest description, and new ones will be required throughout.

8. SANITARY WORK.

This may be conveniently detailed under the headings of—

- a. Sanitary Fittings.* *b. Drainage.*
d. Water Supply.

(*a.*) **Sanitary Fittings.**—These are throughout the house of the most obsolete kind, and should all be removed. This will be the more easy to do because the new sanitary wing, which we suggest should be built, will give the opportunity. For example, the present water-closet on ground floor is of the old D-trap and container, and from use for so many years has become almost eaten through with the acids from sewage.

The servants' water-closet, which is to be removed to the yard, is of the obsolete "hopper" pattern. We would suggest that the ground-floor water-closet should be of the "wash-down" type of any suitable make, and should be provided with "lift-up" seat so as to be used as a urinal. No "casings" should be employed in the new fittings. The up-stairs water-closet may also be of the "wash-down" type or of the "siphonic" type. The **bath** on the first floor should stand on legs and have no "casings," so that the floor, &c., can be easily cleaned. A **housemaid's sink** may be provided for the emptying of slops, but I would strongly advise that the water-closet pan be used for the purpose, as the multiplication of sanitary fittings is not a good thing. The supply to the water-closets must be by means of siphon flushing cisterns. The **soil-pipes** are defective in many parts, they are of lead, but are made of the old type with a seam in them, they are not taken up and ventilated as they should be.

New soil-pipes of **drawn lead** should be inserted and secured to the wall by three tacks in every 10 ft. and taken up 6 ft. above the highest window and covered with a wire cage.

The **scullery sink** is at present of stone and is soaked through and through with accumulated grease. There is an antiquated "bell" trap fixed in it. A new glazed stone-

ware sink should be provided with proper 2-in. anti-D lead-trap with screw inspection eye. This waste should discharge over an open **slipper-pipe** 18 in. long with gully trap at end.

(b.) **Drainage.**—We had the drainage opened up in several parts and find that it is of the most primitive description. It consists of 6-in. pipes, unglazed, butted against each other. They have been laid merely in the ground, on no proper foundation, and the consequence is that, owing to settlements, there is no proper fall, and the sewage has for many years been soaking into the ground surrounding the house.

These old drains must all be taken up and proper 4-in. glazed stoneware socketed drain-pipes, jointed in neat cement, and laid on a 6-in. bed of Portland cement concrete, properly flanchued to top of pipe, laid in their stead.

New gully traps must be placed at the foot of all rain-water pipes, bath wastes, &c., all set on a proper bed of concrete 6 in. thick.

The general setting out of the drains is sketched on the plans. The present cesspools must be emptied out and thoroughly disinfected and filled in with lime-concrete. The new drains will empty into the main sewer now in the road and there should be inspection chambers as sketched. A fresh air inlet should be provided at the lower end of the drainage system and the house drains would be disconnected from the main sewer by a disconnecting trap with inspection eye as sketched on the plan.

9. WATER SUPPLY.

The present water supply is quite unfit for domestic use. We brought away a quart bottle and tested as to colour, taste, smell, with distilled water, and it does not pass the test in any of these particulars.

This is partly accounted for by the fact that the water supply is pumped from a well near the scullery. This well is of the "shallow" kind. Although we cannot find that any of the sewage has actually penetrated into it, yet, as the soil round the house is thoroughly impregnated with faecal

matter, we expect that it may have contaminated it. We suggest, therefore, that the well may be kept for irrigation purposes, but that the house supply should be taken from the new water main in the public road. This will not be a costly matter. The old lead cistern in the roof should be taken away, and a new galvanised iron cistern for 1,000 gallons be fixed in its place, fitted with proper ball-cock and overflow pipe. The cistern-room should be perfectly lighted and well ventilated, so that all dirt can be seen and removed; for ventilation we would suggest that a small dormer window be inserted in the roof to effect this purpose. As to drinking-water, we would suggest that this be taken direct from the main by a tap at the scullery sink. If desired a "Berkefeld" filter can be fixed to the tap, and the drinking water supply thus rendered safe.

10. DISPOSAL OF REFUSE.

All the vegetable matter and garbage should be burnt in the fire-box of the new kitchen range. There is no collection by the Local Authority, so that this devolves upon the occupier.

11. APPROXIMATE ESTIMATES.

We understand the lessor is willing to expend £500 on repairs, renovations, and improvements. This we do not consider to be sufficient. Our estimate is as follows:—

Repairs to walls, floors, roofs, including papering and painting throughout (including erection of new billiard room), we estimate as follows:—	£650 0 0
The erection of the new sanitary wing and the whole of the work comprised in our report of the sanitary condition of house	£350 0 0
	£1,000 0 0

We think the lessor should be asked to expend £600 in order to put the house into a habitable and sanitary condition.

We understand that you, as the lessee, are willing to expend £400 on the alterations and additions, &c., affecting your convenience. We think that this sum may cover the cost of the building of the billiard-room, the *porte cochère*, the insertion of bay windows in drawing-room or dining-room, the formation of passage behind library, and the new stoves and chimney-pieces mentioned in my report. It should also include the necessary heating apparatus. If the lessor agrees to expend the sum as above we think you would be justified in taking the house on a twenty-one years' lease with the usual covenants. Provided the lessor agrees to do this, an architect should be appointed by you to guard your interests in the matter, and the whole of the work should be done to his satisfaction.

We are,

Yours faithfully,

To Sir Henry Crossthwaite.

A TOWN HOUSE.

The following report refers to a town house in which the lessee is willing to expend a sum in alterations, improvements, &c., providing a lease for some years is obtained.

Madam,

Re No. 25, Blank Place.

In accordance with your instructions we have surveyed the above house with the result as set out herewith:—

I. THE HOUSE.

With regard to the planning of this property, we think the value of the house would be greatly increased by some alterations and would suggest that the following works be carried out in order to conform to modern requirements.

Basement.—This contains a butler's pantry, servants' hall, kitchen, scullery, boots, and vault containing room for coals and beer, and there is also a water-closet and cistern.

Dealing first with the butler's pantry, we found this to be rather dark and would suggest the widening of the window on either side in the front area, as shown in fig. 301.

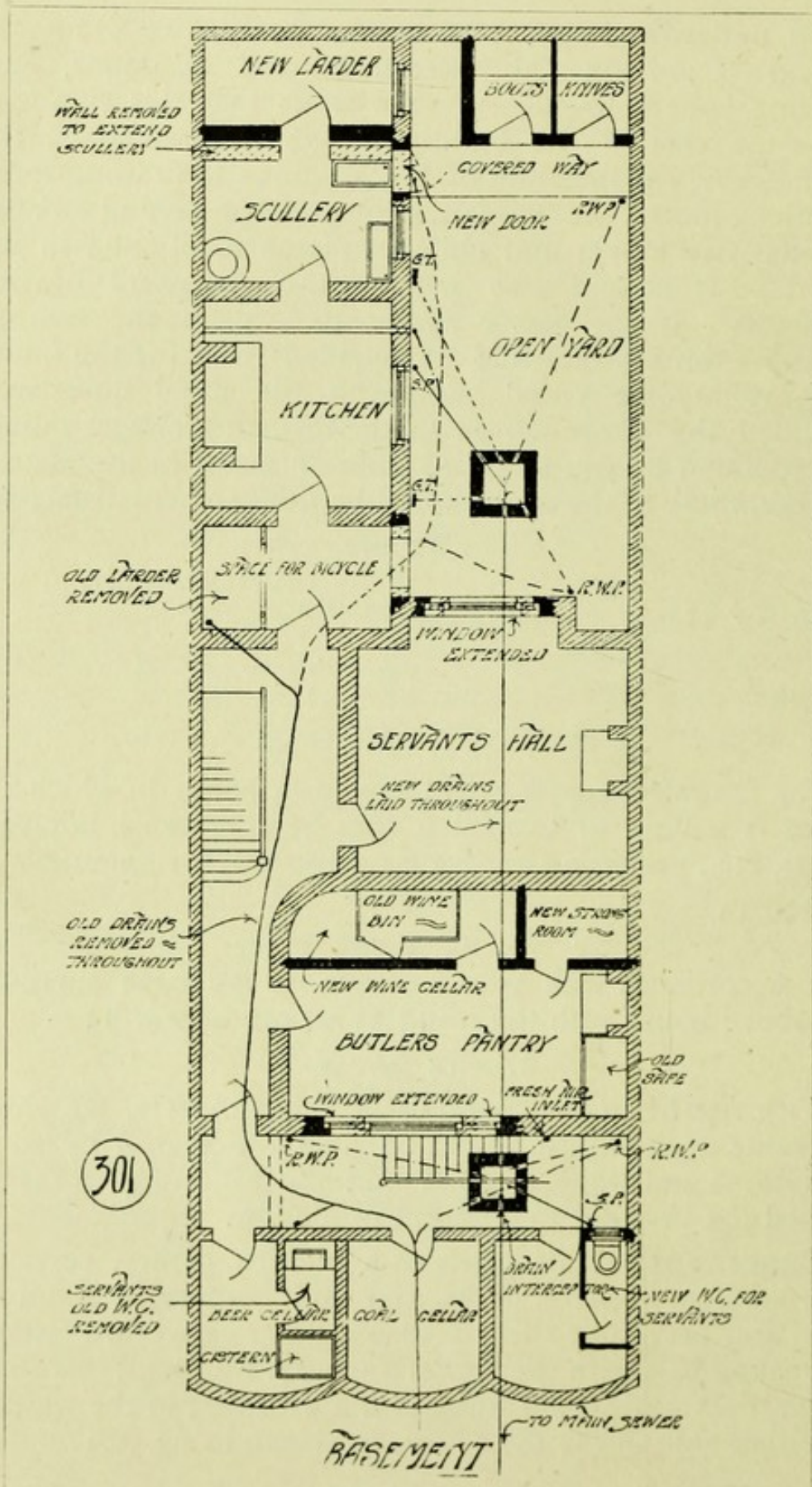

Both the wine cellar and safe are inadequate for the requirements of the house, and we would suggest erecting a partition, as shown, using the larger portion for wine and the remainder as a strong room. The old safe could be retained and used as a china cupboard.

With regard to the larder, this is too small and has no outer ventilation; we would suggest it being entirely removed and the space used for a bicycle store. We would also suggest the widening of the present opening leading into yard which will give more light and ventilation. By doing this the scullery could be enlarged and the space at present used for "boots" would make a very good larder. A covered way could then be built leading to the proposed one-storey building for "boots and knives." This would necessitate removing the sink in scullery and erecting a door in its place as shown in the diagram.

The lighting to the servants' hall is inefficient, and we would suggest the widening of the existing window on each side. With regard to the drainage shown in this figure we have dealt with this subsequently.

Ground Floor.—With regard to the ground floor, we think it advisable to remove the wall and door at the top of the stairs from basement, as shown in fig. 302, and arch it over. By enlarging the window overlooking the yard, a space for hats and coats can be obtained, and the stairs will be much better lighted. The present water-closet in this space will be entirely removed, as mentioned later. The room adjoining this space we have devoted to the water-closet and lavatory, which will be adequately lighted by the enlarged windows. The passage beyond this lavatory and water-closet will be sufficiently lighted by Muranese glass being placed in the upper half of the partition. The present door will be blocked up and the new one moved nearer the wall, and the existing chimney-breast will be removed as shown.

The next room we propose to devote to forming a new study. A reference to the ground floor plan (No. 302) will show what a capital room this will make. It will be formed by building over the present "boots," and we think will make a most useful room. To be properly lighted, a new

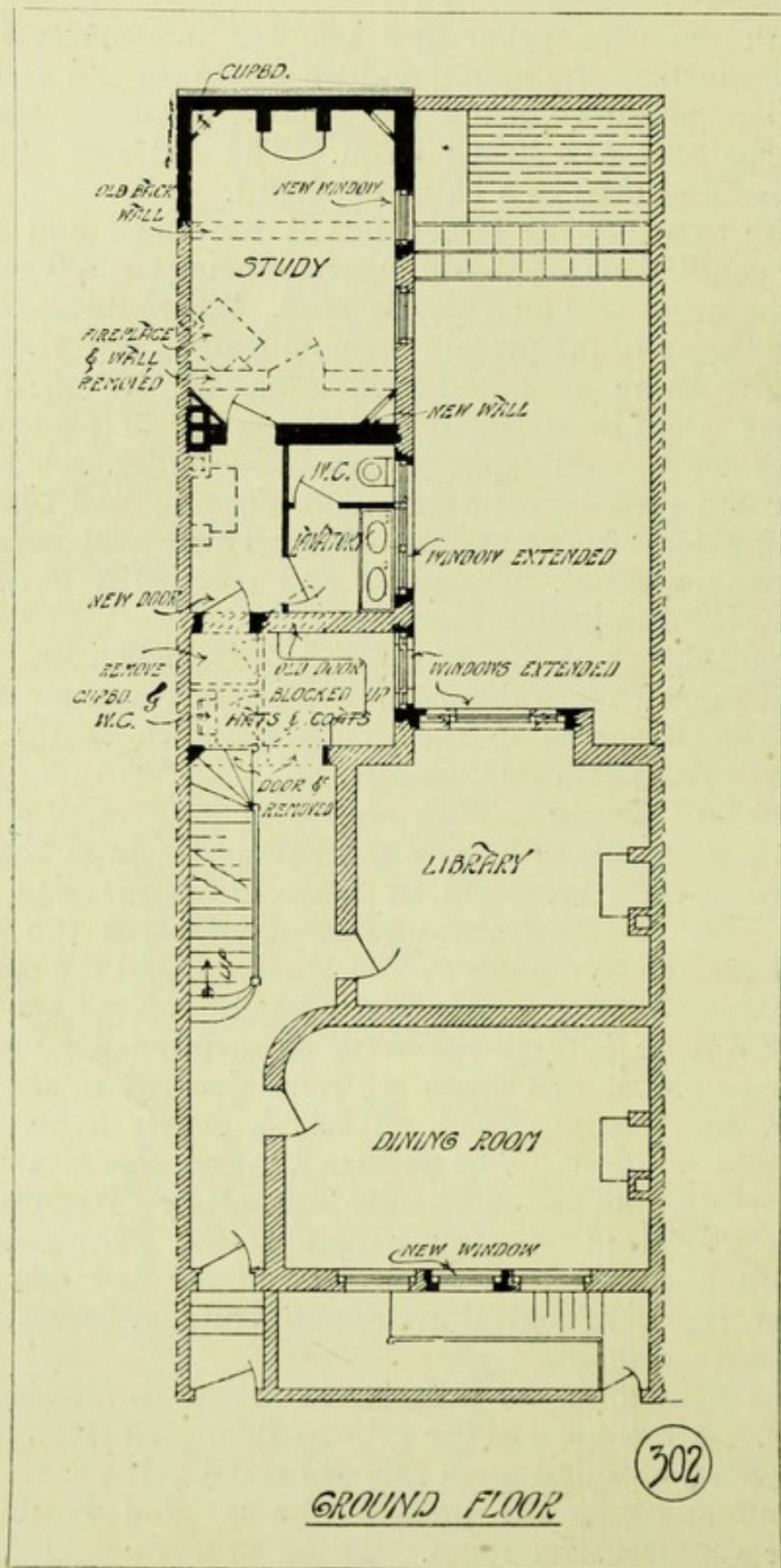

window will be required as shown, and the erection of a new chimney-breast.

At present the dining-room is lighted by two windows 3 ft. 6 in. wide. These do not light this important room at all well, and we propose inserting, as shown, between the two windows another window 3 ft. wide.

The library beyond suffers in the same way as the room below (the servants' hall), and we have shown a similar widening of the window.

First Floor. —

On this floor (fig. 303) we propose doing away with the wall and door at the top of the stairs as in the floor below, thus forming a useful alcove. It will be seen by a reference to the plan that over the study on the floor below a boudoir can be placed, and over the water-closet, &c., on the ground floor, a china closet and a ladies' lavatory can be placed conveniently adjacent to the boudoir.

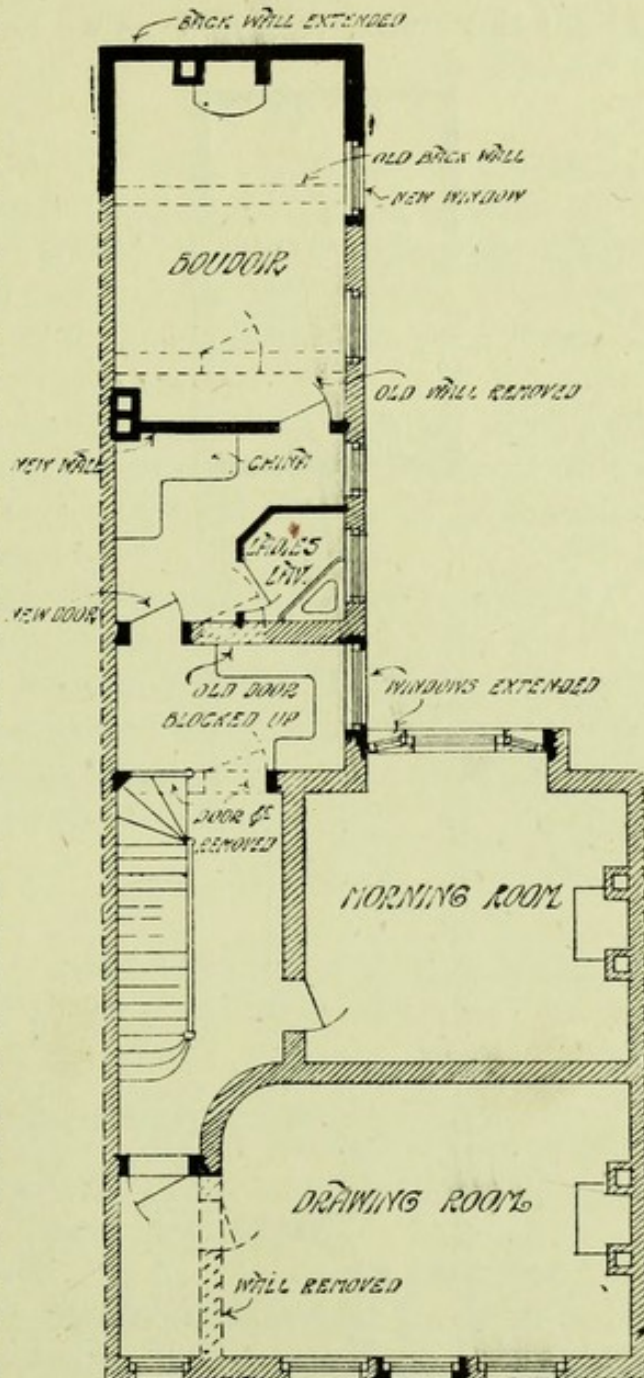

FIRST FLOOR PLAN

303

In the front of the house there is a long passage with a window facing the street, which was evidently constructed to light the stairs, &c., and as we have already proposed to

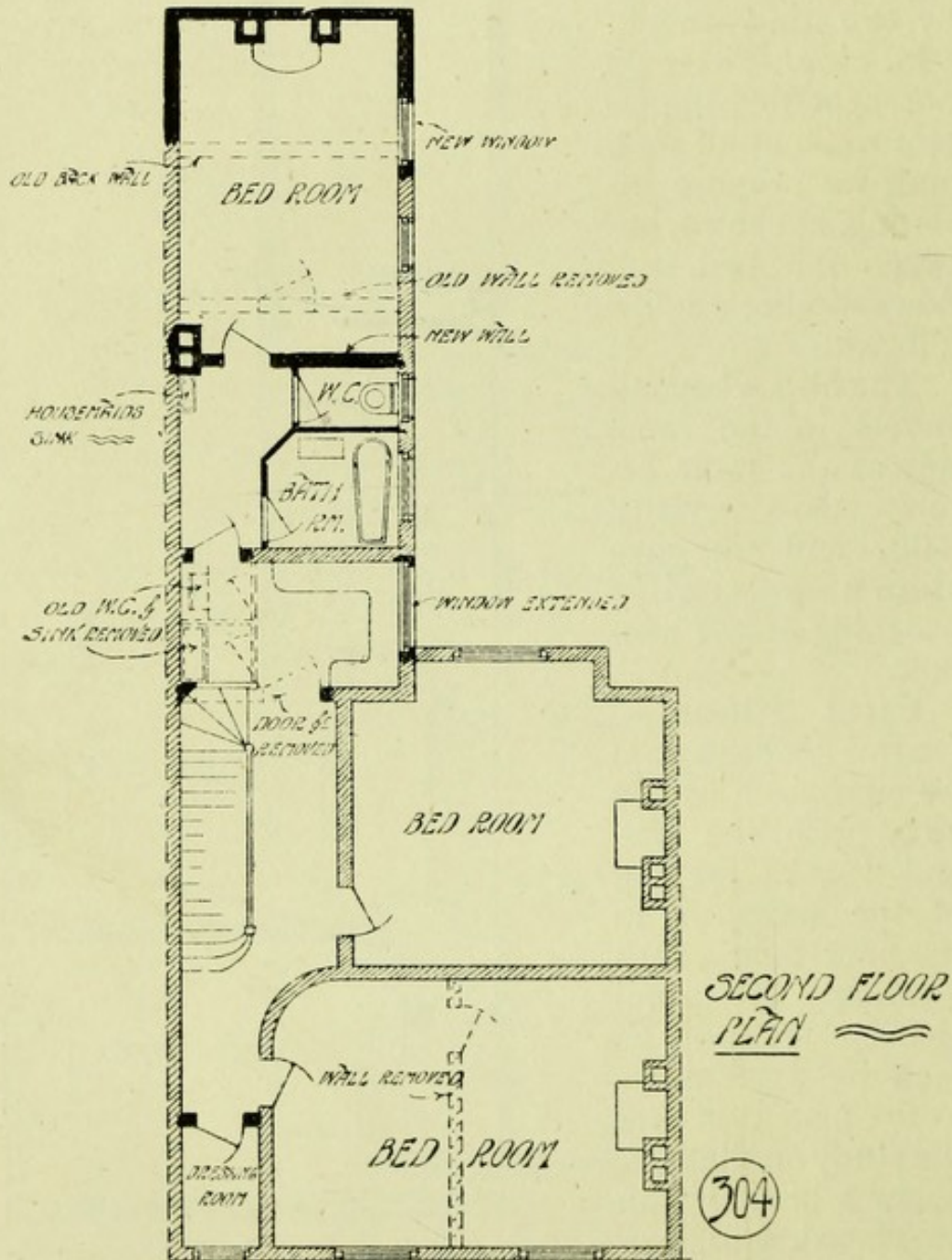

enlarge the window and do away with the wall at the top of the stairs, this window would be of no further use and the space used as a passage would be wasted. We therefore propose extending the front drawing-room, as

shown, by removing a portion of the wall. Thus the drawing-room will extend the whole frontage of the house.

In the morning-room beyond we propose erecting two side windows on the angle which will give a bay window in the thickness of the wall.

Second Floor.—On this floor (fig. 304) we propose to remove the old water-closet and housemaid's sink (unventilated) at the top of the stairs, as shown, and to construct a water-closet as on the ground floor, and it will be noticed a bathroom is obtained, which is a necessary to a house of this description.

Another bedroom is placed over the boudoir. The stairs are lighted by the enlarged window, as on the floors below. With regard to the passage in the front, it will be seen that this is utilised by making it a dressing-room.

The partition dividing the two bedrooms in the front is, we think, altogether unnecessary, and makes the rooms of a very awkward shape, besides having the disadvantage of making one of the rooms a "thoroughfare" room. We therefore propose entirely doing away with this partition wall, and making one principal bedroom.

2. WALLS.

Some portions of the walls, especially at the back, are in need of pointing. We would suggest the whole of the back front being pointed up in cement, especially the window-frames, where we found in every case that the pointing was very defective. The window-sills are in a chipped and defective state, and we would suggest that they all have a cement face floated over them.

With regard to the pointing in the front, we think that if the wall is pointed up from the ground to the level of the sills at the ground-floor level, and down three feet below the eaves gutter at the top that this would be sufficient, although it would be advisable that all the window-frames be pointed as at the back.

Internally the partitions are of the strong brick nogged type, and nothing need be done to them, except, of course, making good after removal of walls, &c.

3. FLOORS.

With regard to the flooring generally, we found this in a very fair state, and do not consider anything need be done to this, except tightening up the stairs and fixing new nosings throughout.

In the erection of the new boudoir we would suggest the flooring be laid with wood blocks.

The basement is floored through with boarding resting on joists supported on sleeper walls. The space under the floor is entirely unventilated, and in consequence "dry-rot" has set in. Several joists will have to be removed, and ventilating gratings must be inserted, so as to create a through current of air.

4. CEILINGS.

These we found in a very dirty and stained condition, and require washing, stopping, and twice whitening throughout.

The ceilings to the top floor are very bulged, and in some cases wet has found its way through. These defects should be carefully cut out and repaired before being whitened.

5. WINDOWS.

The windows throughout require easing, and in several instances require new sash lines, also a few cracked squares require reinstating. The defective pointing to the frames has already been dealt with.

6. ROOFS.

The roof requires overhauling, as several slates have slipped into the gutter, and consequently wet has got in and rotted the timbers, and therefore has damaged the ceilings to the top-floor rooms.

New timbers should be inserted where decayed, and the slates effectively fixed to the battens.

The lead flashings are in a very perished state. We think it would be wise to insert new flashings throughout. We noticed that merely a cement fillet was fixed along the chimney-stack. This should be removed and proper stepped flashing substituted.

All the chimney pots require flaunching up, and the new pot is required to re-instate present broken one.

7. DECORATION.

The walls on the ground, first, and second floors will have to be stripped and re-papered throughout, whilst the basement walls should be distempered the same tint as at present.

With regard to the new study and the boudoir, &c., we would suggest a pine dado, stained green, surrounding the rooms some six feet high, and the space above distempered a pale terra cotta colour, and the whole crowned with a frieze.

The cornices throughout require picking out before whitening; at present the beauty of the mouldings is lost by the accumulated whitening of past years.

The whole of the internal wood-work requires scraping down and painting, and the varnish-work requires burning off and re-instating. We would suggest that the worn paint-work to the balusters be scraped off, and in lieu thereof should be varnished and polished, which apparently was originally done.

8. HEATING AND VENTILATION.

The fireplaces appear in a satisfactory state and serve their purpose, although of a somewhat antique and wasteful pattern. The new fireplaces we would suggest being of the "Teale" or other approved slow-combustion type.

With regard to the ventilation, at present the only ventilation is what is derived from open windows, &c., and as this serves the purpose we do not propose altering or adding to it materially, but would suggest that deep ventilating beads be inserted to all windows.

9. SANITARY FITTINGS.

These, we find, are of a rather antiquated pattern. The servants' water-closet in vault under the pavement we found to be of the old pan type, with D-trap, and in a filthy condition; this should be entirely removed and a wash-down closet of approved type be fixed. Abutting against this

water-closet at present is the cold water supply cistern ; this is a most undesirable position, the water being so liable to contamination from the water-closet. We would suggest that the water-closet be removed to the third vault, as shown, in which there will be plenty of room.

The water-closet on the first floor is in a most unsatisfactory position, with no possible chance of being ventilated or lighted, and is of the condemned long-hopper type. This should be entirely removed and rebuilt, as shown, with an approved closet of the siphonic type and lift-up seat, in which case it can be used as a urinal. By this means it can be properly ventilated and lighted and discharge in a soil pipe of drawn lead. This new space will also allow the construction of a new lavatory, of which the house is in need.

Another water-closet, in a similar position and with the same disadvantages, is placed on the second floor, with a housemaid's sink adjoining. This should be treated in a similar manner as on the ground floor, and also a bathroom erected as shown. The housemaid's sink should be moved along the passage. All these new fittings would be supplied with anti-siphonage pipes. At present there are none to any traps, the soil being simply discharged direct into the soil pipes.

The occupier informed us that often bad smells have been noticed, and we have no doubt these traps have become unsealed on many occasions and the foul drain air has found easy access to the rooms.

10. DRAINAGE.

This we found to be in such a defective state that only the taking-up and the proper re-laying will put the drainage in a satisfactory condition.

Taking first the line of drainage, a reference to the basement plan, Fig. 301, will show how irregular and badly laid this is.

On testing them the smell that found its way into the house and yard left no doubt of some very serious defects, and upon taking up the ground in the area we found that the pipes had merely been irregularly laid on the ground,

with no concrete bed, and the joint between spigot and socket was in every case merely smeared round with clay, which in most places had cracked and broken away.

There is at present no inspection chamber, and when the drain has been stopped up, which we are informed is a rather frequent occurrence, great difficulty has been experienced in getting canes and rods through. Of course, such irregular drain-laying as this offers every facility for stoppages.

We have no doubt when the earth is taken up through the whole length of the drain, that several pipes will be found to be broken.

With regard to the soil pipes, &c., these are of iron and in a very rusty and defective condition. Most of the joints were defective, and in those near the ground we found that the proper lead caulking had been replaced by old rags. Again, the ears connecting these pipes to the walls are breaking away and the nails missing. In the rain-water pipe in the yard the shoe has entirely gone, and the water splashes down about two or three feet, soaking and damaging the wall. We think the safest way of dealing with this is to do away with all these old defective down pipes, and substitute drawn lead with wiped joints. This will allow of the soil pipe being properly ventilated and crowned with a wire domed head.

On the basement plan we have shown what we consider a satisfactory method of dealing with this system of drainage. It will be seen that a straight line of drainage from all the branch drains is planned to the inspection chamber in the yard, and the advantage of a perfectly straight line is obtained from one inspection chamber to the other.

Of course, in a town house of this description the drains must pass under the house, but no apprehension need be felt on this account if the drain pipes are bedded in concrete.

The drain pipes in this case will be four inches in diameter until they reach the manhole in the backyard, and from thence to the sewer they will be six inches in diameter.

II. WATER SUPPLY.

This we found to be from the New River Company. All the water fittings require overhauling, all the new fittings being of approved pattern. The unhealthy position of the cistern has been already mentioned, and its liability to contamination; its revised position will render it impossible to be contaminated. The cistern at the top of the house will supply the water-closets and be disconnected from them by means of water-waste preventers. We would suggest that the drinking water be taken direct from the main by a special tap, and a Berkefeld filter fitted to this tap.

12. DISPOSAL OF SEWAGE.

The sewer is in the centre of the road and is maintained by the Local Authority, the sewage being efficiently treated at their works some two miles distant, and the ventilation of the sewer being effective.

All garbage, &c., should be deposited in galvanised iron sanitary bins and collected by the authorities; no refuse is therefore allowed to accumulate on the premises as in the old-fashioned brick dust-bin.

13. ESTIMATE OF COST.

We estimate the cost of the repairing throughout and the erection of the new rooms, &c., to be £1,000.

Provided that the landlord is willing to grant you a 21 years' lease, we think that your ladyship would be justified in expending this amount in consideration of the rent not being raised. The alterations will render the house a very attractive one, and the neighbourhood is continually improving in character.

Your ladyship will be well advised to stipulate that the work should be carried out to your architect's satisfaction.

We are,

Yours faithfully,

The Right Hon. Lady Reaney.

A SMALL SUBURBAN HOUSE.

DEAR SIR,

3, *Mincull Road, Elling.*

We have surveyed these premises in accordance with your instructions, with the object of advising you as to their sanitary condition, and we have to report as follows:—

The premises are situated upon a healthy sandy soil and are about half-a-mile from the station on the L. S. & C. Railway. The premises are double-fronted, with two stories, and face towards the south-east. They are built of red bricks with Ketton stone dressings and are covered

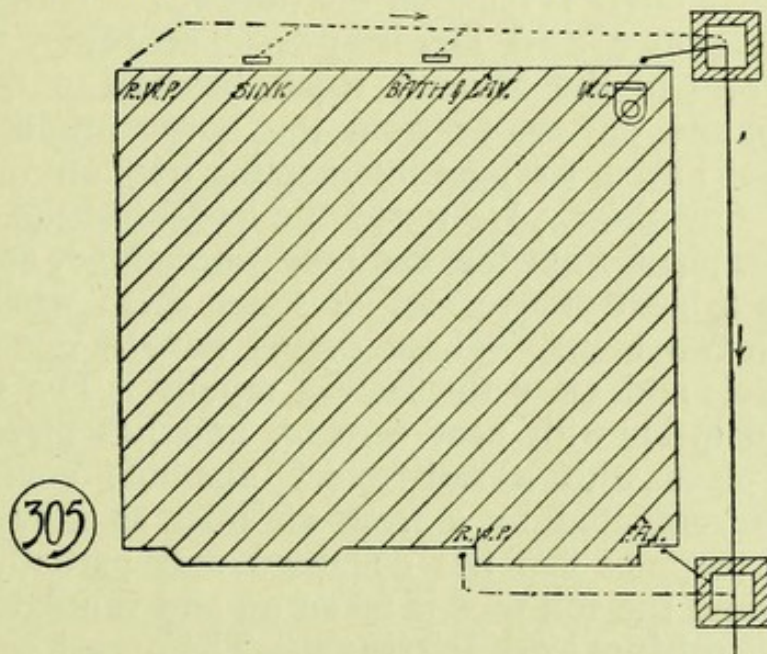

with a tiled roof. Externally they are in a fair state of repair, and the painting covenants were observed last year in accordance with the terms of the lease. They contain four bedrooms, one dressing-room, two sitting-rooms, and bath-room, water-closet, kitchen, scullery, and coal-cellar. There is also a servants' water-closet, which is entered from the back garden. The sketch block plan (Fig. 305) will give you some idea of the premises.

(a) **Heating and Ventilation.**—The late tenant had slow combustion stoves fixed in all the rooms, and they are of a good and useful pattern. The ventilation also is fairly satisfactory, *Tobin* tube inlets being fixed in most

of the rooms, and the window space and openings being sufficient for their purpose. There is no system of heating by hot water, and probably you will not consider it necessary in this small house. The hot water supply to bath is heated by a defective saddle boiler from the kitchen range, which latter is of a good type.

(*b*) **Water Supply.**—This is obtained from the Central Junction Company, and a separate supply direct from the main is provided for drinking purposes. The water, we find on examination, is of a fair quality, but contains some little quantity of suspended matters.

The cistern, which is in the roof space, is very foul, and the defective cover is lying on the rafters.

(*c*) **Sewerage and Drainage.**—The sewer, which is in the centre of the Mincull Road, belongs to the Local Authority, and the drains from the house are connected thereto and have a Crapper intercepting trap on the sewer side of the manhole. We tested the lengths of the earthenware drain pipes from the manhole throughout, and found that with a head of five feet of water there was no subsidence in two hours. These drains have a good fall to the manhole and clear themselves rapidly. The manhole is finished inside with neat cement, and has glazed open channel pipes with a satisfactory manhole cover. The system is ventilated by a fresh air inlet as shown on the plan, but the mica flap has collapsed and partially blocks the pipe, and the soil pipe is taken up and ventilated.

(*d*) **Plumbing and Fittings.**—The upcast ventilating shaft on the west front is not carried to a sufficient height above the roof, and drain air is drawn through the tiles into the roof space and so may contaminate the water in the cistern. Unfortunately the tiles are laid on battens with no covering (such as felt and Willesden paper) between them, moreover, the overflow pipe to the cistern is in close proximity to the outgo of the upcast shaft. Distinct traces of asafœtida and smoke were found here after the tests. The fittings are satisfactory with the exception of the lead-lined sink and the servants' water-closet. The former requires re-dressing and the latter is of the old and foul long-hopper variety, and this should be removed and wash-

down closet fitted. There are no anti-siphonage pipes at all to the system.

(*e*) **Lighting.**—Gas is the illuminant, and Welsbach incandescent burners are used. We tested the system and find small leaks in the two front bedrooms.

(*f*) **Refuse.**—The kitchener has a fire-box for the destruction of vegetable refuse. The dustbin is properly constructed, though not cemented internally, and the Local Authorities send twice a week to empty this.

Works to be done.

(*a*) A new saddle-back boiler must be fitted to the kitchen range.

(*b*) A "Berkefeld" or "Pasteur-Chamberland" filter should be fitted to the drinking supply direct from the main. A proper cover must be provided for the supply cistern.

(*c*) A fresh inlet with silk flap should be fixed to the inlet ventilation pipe.

(*d*) The present ventilating shaft should have the existing small zinc bend removed, and two 6-foot lengths of stout galvanised iron piping should be jointed to the present iron up-cast shaft. These should be secured to roof with copper ties. It would be well to line the inside of the battens to the roof with Willesden paper; this need not be continued more than 12 feet each side of the up-cast shaft, but it would be preferable to do the whole of the roof.

The lead-lined sink must be re-dressed, and a wash-down closet fixed to the outside water-closet.

Anti-siphonage pipes must be instituted to all the fittings and carried up above the topmost water-closet.

(*e*) The leaks to the gas pipes must be repaired, and a "Stott" governor should be fixed near the meter, which not only saves the consumption of gas, but also can always be used to detect leaks.

(*f*) The dustbin must be cleaned out and rendered in cement, so as to be impervious.

We estimate that the cost of these works will amount to £46.

We are, yours faithfully,

To Col. Blonde, R.A.

NOTES

—

INDEX.

	PAGE		PAGE
A		B	
Absorption of water by Bath stone	31	Army infant schools, cubic space... ..	145
Access to drains	49	Army permanent barracks, cubic space	145
Acetylene, manufacture of ...	206	Artesian wells	118
Addison's patent plug for drain testing	220	Artificial lighting	201
Adjusting-self joint, Doulton's	43	Artificial ventilation	157
Admission of solar light to buildings	197	Asbestic, Danville	36
Air bricks	32	" lining	188
" chambers	136	Ashpits... ..	9
" composition of	137, 140	Aspect	19
" currents, movement of	137, 138	Asphyxiator, simple smoke machine	218
" impurities of	137, 141	Assisted natural lighting ...	199
" inlets, Ellison's	153	"Astragal" joints	82
" quantity, per person, per hour	145	Automatic flushing closets ...	79
" quantity required and its measurement	137, 143	B	
Alterations, report on... ..	224	Back flow, Couzen's patent for prevention of same	57
Amines process of precipitating sewage	99	Bacteria tank at Sutton	100
Ammonia compounds... ..	142	Bacterial filter, Dibdin's	100
" test for in gas	202	Baillie's & Burn's eclipse smoke generator	218
Anderson's observation on ventilation	157	Banner drain grenade, use of... ..	216
"Angle" plug, Messrs Burn's	220	Banqueting halls, lighting of... ..	202
Anthracite as fuel	163	Barracks and drill sheds, lighting of	202
Anti-D trap	65	"Barrel Union" for joining iron piping	132
Approximate estimate, for repairs, &c.	234, 246	Bars, Fire	165
"Arc" lamp	211	Basin, waste for	133
"Argand burner"	205	" water-closet	69
Armature, definition of	207	Bath rooms	21
Army chapel schools, cubic space... ..	145	" section of	84
Army hospital wards, cubic space... ..	145	" stone, absorption of water	31
		" waste, plug form	133
		Baths	21, 51, 232
		" and their wastes	84

	PAGE		PAGE
"Bat-wing" burner ...	204	Candles, lighting by ...	201
Bed, position of ...	22	Cap and lining of pipes ...	132
Bedrooms ...	22, 180	Carbonates, magnesian... ..	122
Belcher's smoke preventer ..	177	Carbonic acid	141
"Bell" trap	52, 63	,, acid, test for, in gas... ..	202
"Benching up" of drain pipes	49	,, Oxide	141
Bends in pipes... ..	46	Carnelly's observation on ven-	
Berkefeld's filters 121, 246, 249		tilation	157
"Bib" tap (Lord Kelvin's) ...	134	Carpets	38
Billiard room, position of ...	21	Ceilings, state of	229, 242
,, ventilation and		Cellars	6, 180
heating of	195	Cesspools	9, 11, 93
Blue Staffordshire Bricks,		Chalk	15
absorption of water... ..	31	Chamberland-Pasteur filters ...	120
Board schools, lighting of ...	202	Chambers, air	136
,, Education De-		,, rule, proportion of	
partment, cubic		windows	197
space in.	145	Channel shoe, Broad's	54
Boats, canal, cubic space		Chapel with galleries, ventila-	
required in	145	tion and heating	193
Boiler screw, with cap and		Chapels and churches, lighting	
lining... ..	133	of	202
Boilers, lime deposit in. ...	123	Chimney-stacks, repair of ...	230
"Bracket" closet, Messrs.		Chimneys	7, 35, 165
Dent & Hellyer	74	Churches, heating and ventila-	
Bricks, air	32	tion	180
,, salt-glazed	48	Cisterns, cold water	166
Broad's pedestal bend-pipe ...	46	,, earthenware	122
,, channel shoe	54	,, lead	122
,, connecting pipes	48	,, slate	122
,, manhole covers..	50	Clark's (Dr.) process for remov-	
Building Act, London..	11	ing temporary hardness of	
Bungalow, plan of	25	water... ..	123
Burnett & Groom's tester ...	218	Clay soils	15
Burn & Baillie's eclipse smoke		Climate, local	16
generator	218	Close stoves	162, 168
Burner, Argand	205	Closet, basin	69
,, "Bat-wing"	204	Closets	8, 10, 79
,, "Fish-tail"	204	,, automatic flushing	79
Burners... ..	204	,, trough	79
Burn's "Angle Plug"... ..	220	Coil, enclosed in cylinder, hot	
Butler's sinks	89	water circulation	173
		Coils and radiators	166
		Coke-breeze concrete	37
		Colours, primary	196
		Combustion	142
		Common lodging houses ...	145
		Common stocks, absorption of	
		water... ..	31
		Commutator, use of	207

C

Calcic carbonates	122
Callender's composition, as	
damp course... ..	32
Canal boats, cubic space	
required in	145

	PAGE		PAGE
Drainage pipes, fall of	... 104		
,, of terrace houses	... 106		
,, and sewerage	215, 248		
Drains, access to	... 49		
Drawing-room, aspect of	... 20		
Drawn lead	... 232		
Drill-sheds, lighting of	... 202		
Driving pump, water wheel	... 127		
Dry-rot	... 39		
Duck-pipe	... 38		
Duckett's slop-water closet	... 94		
,, self-cleansing channel			
gully	... 54		
Dustbin	... 91		
Dynamo, use of	... 207		
E			
Earth closet	... 93		
Earthenware cisterns	... 122		
Earthenware and iron pipes	... 3		
Earthenware traps	... 62		
Eclipse smoke generator	218, 222		
Educational department's re-			
quirements	... 181		
Egg-shaped form of sewer	... 95		
Electricity	... 171, 224		
Electric radiator	... 172		
,, cooking-stoves	... 172		
,, flat-iron	... 172		
,, hot-plates	... 172		
,, kettle	... 172		
,, light	... 201, 206		
,, saucepan	... 172		
,, stoves for cooking	... 172		
Ellison's air-inlets	... 153		
Entrance hall and staircase	... 19		
,, lodge	... 26		
Estimates, approximate, for			
repairs	... 234, 246		
Evans & Swain's patent floor-			
ing	... 37		
Evaporation in traps	... 63		
Examination of water	... 114, 121		
External Reflectors	... 199		
Extract coil	... 179		
,, ventilator	... 181		
Extracting power of flues	... 156		
Extracts, for foul air	... 181		
		F	
		Factory and workshop Acts	... 9
		Fall of drainage pipes...	... 104
		Fall of ground...	... 16
		Fanlights ventilating	... 178
		Female screw	... 132
		Fever, malarial	... 142
		Filtration	... 120
		Fire bars	... 165
		Fire regulator, Dr. Lee's	... 160
		"Fish-tail" burner	... 204
		Filters, Berkefeld's	121, 246, 249
		Filters household	... 120
		Fittings, water supply	... 133
		Fittings for lights	... 209
		Fittings and plumbing...	222, 248
		Fittings, sanitary	... 232
		"Flaming Kitchener Cheek"	161
		Flap valve	... 135
		Flats	... 12
		Floor coverings	... 38
		,, first, report on	... 239
		Flooring parquet	... 38
		Floors, Evans & Swain's	... 37
		,, grooved and tongued...	36
		,, ordinary	... 36
		,, solid	... 36
		,, state of...	229, 242
		Flue pipes, ventilating, Dou-	
		lton's	... 155
		Flues, extracting power of	... 156
		Flushers, drain, use of bath	
		waste...	... 21
		Flushing cisterns and waste	
		water preventers	... 80
		Flushing closets, automatic	... 79
		Flushing gully	... 57
		Flushing tank, automatic for	
		drains	... 104
		Force pump	... 118
		Foul air extractor	... 181
		Foundations	... 2, 7, 13
		Frankland, Dr. Percy, theory	
		on running stream	... 98
		Fresh air inlet, free circulation	
		of air	... 16
		Fresh air inlet, mica flap for...	155
		Fresh air required in drains	... 58
		Fuel, "anthracite" as	... 163

	PAGE		PAGE
Fuller bib tap	135, 136	Hall with flat plaster ceiling, ventilation of	187
"Full-way" ball valve	135	Haldane's observations on ventilation	157
" " valve	134	Hard stocks, absorption of water	31
Furnishing of a house	40	Hard woods	12
G			
Galleries of chapel	193	Harding's diffuser	149
Galton's ventilating grate 154,	190	Hardness of water 114, 122, 123	
Galvanised iron	122	Health, plan in regard to	2
Gas escape detector	223	Healthiness	16
Gas, impurities in	202	Heat	138
" lighting by	201	" convexed	159
" for grates	162	Heating ... 3, 159, 184, 186	
Glass, nature of	199	" and ventilation	231, 243, 247
Glass surface	184, 186	" and ventilation	schemes 178
Glazed tiles for reflecting light	35, 199	" means of, in report 214	
Glazing	198	Height of buildings	12
Good sandstones, absorption of water	31	Hellyer's anti-D trap	62, 65
Governor, Stott's	204	" lavatories	86
Governors for regulating gas supply	203	Henman's plenum system	189
Granite, absorption of water	31	Hermite process of precipi- tating sewage	98
Grates, open	159	High pressure system hot- water apparatus	167
Gravel	15	Hollow walls	33
Grease traps	53	Hood's rule for ventilation	152
Grenade or ferret	216	Horizontal damp courses	32
Grey stocks, absorption of water	31	Hospital, cottage	29
Groom's, Burnett &, tester	218	" drainage, plan of	113
Grooved and tongued flooring.	36	" isolated	25
Ground, air	14	" plan of	27
" floor	237	" ventilation of	189
" made	15	" wards	202
Gullies	3	Hot-air heating system	171
Gully, Duckett's self-cleansing channel	54	Hot-plates, electric	172
Gully traps	51, 52	Hot-water apparatus	164
Gutters, rain-water	114	" coils	179
Gwilt's rule for windows 18,	198	" piping	181
H			
Habitable basements	33	" supply	173
" rooms	12	House, report on for repairs	225, 235
Hall, banqueting, lighting of..	202	" drainage	3, 41
" large	185	" without basement	32
" and staircase	179	Household filters	120
		Housemaid's sinks	89, 232
		Houses, ventilation and heat- ing of... ..	178

	PAGE		PAGE
Hydraulic pressed tiles	... 38		
,, ram 125		
,, test of drain	216, 219		
I			
Illumination, measuring power			
of 202		
Illumination required for			
various purposes :—	202		
	Candle-power per 1,000 sq. ft. of area.		
Country roads ½		
Small towns 4		
Large towns 10		
Hospital wards	... 50 to 100		
Barracks and drill- sheds...	... 50 to 100		
Cottage parlours 150		
Villa dining-rooms 250		
Board schools... 300		
Churches and chapels 300		
Banqueting halls, &c. 450		
Improvements, report on a			
house... 224		
Impurities in air	... 137, 141		
,, in gas 202		
,, in water	... 114, 119		
Incandescent lamp 210		
Incandescent, mantleless 205		
,, Welsbach Gas			
Light Co. 205		
Inlet, Doulton's 153		
Inlet pipe for ventilation of			
drain 59		
Inlets flue for ventilation	139, 140		
Inlets, size of, according to Dr.			
Corfield 152		
Inspection chambers 47		
,, of drains... 47		
,, lantern, Doughty's.	221		
,, pipes 50		
Intercepting trap 49		
International Company's sys- tem of precipitating sewage.	99		
Iron drain pipes 44		
,, electric flat, 172		
,, soil-pipes, method of joining 84		
Irrigation 95		
Isolation block... 25		
,, hospital 25		
		J	
Jennings & Morley's siphonic			
discharge closet 77		
Jenson's pneumatic machine	... 222		
Joint, "astragal" 82		
,, "connection" 132		
,, "metallo-ceramic" 73		
Jointing of drain pipes 42		
,, of iron soil pipes 81		
,, of lead soil pipes 81		
Joints between pipes 73		
,, patent 43		
Jones's patent manhole cover...	50		
Jones's patent pipe stopper	... 220		
Junction of waste to bath	... 133		
Junctions between pipes	45, 131		
		K	
Kelvin's (Lord) patent "bib- tap" 134		
Kemp's patent drain tester	... 217		
Kentish rag, absorption of water... 31		
Kettle, electric 172		
Kettles, lime deposits in	... 123		
Kitchen, lighting of 21		
,, offices, position of 21		
,, ventilation and heating of 179		
		L	
Lake water 115		
Lamp, arc 211		
Lamp, incandescent 210		
Lantern light 179		
Larder, position of 22		
Large country house	... 105, 111		
,, hall, ventilation scheme for 185		
,, towns, lighting of	... 202		
,, wards, ventilation of	... 190		
Latrines or trough closets	... 79		
Lavatories	... 21, 51, 180		
,, and their wastes	... 86		
,, Hellyer's	... 86		
,, tip-up	... 86		

	PAGE		PAGE
Open spaces	7, 11	Plan of isolated block... ..	25
"Optimus" valve closet	75	" " hospital	25
Ordinary basin with plug lavatory	86	" semi-detached houses..	25
Ordinary floors	36	" town house	26
Outlet flue for ventilation 139, 140		" workmen's cottages ...	26
" pipe	59	Plans, drainage	104
Outlets, ventilation, position and size of	9	Plastering	36
Oxide, carbonic	141	Plenum system, Henman's 157, 189, 191	
Oxygen in air... ..	140	Ploughed and tongued flooring	36
Oxygen sewage, purification system	100	Plug-form of bath waste ...	133
"Oxynite," use of	101	Plug valve closet	77
Ozone in air	140	" Addison's patent... ..	220
		Plumbing and fittings... ..	222, 248
		Pneumatic test of drains 216, 222	
		" machine, Jensen	222
		Pole switch, double	209
		Pollution, water supply 3, 114	
		Porous soils	15
		Porter-Clarke system for removing hardness of water ...	123
		Portland cement concrete ..	17
		Portland stone, absorption of water... ..	31
		Position of bed in room	22
		" site	15
		" ventilation inlet	149
		" " outlet.. ..	153
		" windows	198
		Potterton's combined radiator .	176
		Power of extracting flues ...	156
		Precipitating sewage, Amines process	99
		Precipitating sewage, International Co.'s system ..	99
		Precipitation of sewage, Scott Moncrieff's process	99
		Preliminary remarks	67
		Pressure-low, system	164
		Prevention of smoke	177
		Pridgin Teale's stoves	159
		Primary colours	196
		Prisms, Luxfer... ..	199
		Prisons with separate cells, ventilation of	145
		Privies	8, 92
		Procedure, when site selected	17
		Production of electric current ..	206
		Proportion of windows	197

P

P-trap	64, 72
Pail-system of earth closet ...	93
Pan-closet	70
Pantry, position of	22
"Parged and cored" flue	155
Park hospital	112
Parlours, cottages	202
Parquet flooring	38
Pasteur-Chamberland filter ...	120
Patent joints for drain-pipes ...	43
Pedestal bend, Broad's	46
Permanent hardness of water	122
Perry & Adeney's sewage purification	101
Physical properties of water ...	118
Picture galleries, ventilation of	178, 191
Pipes, flue ventilation... ..	155
" size of	45
" steam	168
" stopper, Jones' patent... ..	220
" with regard to heating	166
" " " lighting	202
Plan of bungalow	25
" cottage hospital	29
" country house... ..	28
" detached house	23
" doctor's small house	26
" entrance lodge	26
" hospital	27
" house in regard to health and convenience	218

	PAGE		PAGE
Prospect	19	" Salamandre " stoves ...	163
Public Health Act ...	6, 10, 97	Salt-glazed bricks	48
Pulp papers	35	Sanitary construction ...	2, 30
		,, fittings 3, 67, 232, 243	
		,, inspection	4, 213
		,, legislation	2, 6
		,, work	232
		Saucepan, electric	172
		Schools, ventilation of ..	181
		Schools of art, ventilation of..	191
		Scott Moncrieff's process of	
		precipitating sewage ...	99
		Screw-down valve	134, 166
		Scullery, position of	22, 179
		Scullery sinks	53, 88, 232
		Section of bath	84
		Self-adjusting joint, Doulton's	43
		Self-cleansing channel gully,	
		Duckett's	54
		Semi-detached houses	
		25, 105, 107, 108	
		Separate steam radiator ...	190
		Separation of buildings ...	12
		Septic tank, system for in-	
		creasing "micro-organisms"	99
		Sewage, collection of	92
		,, discharge into river... ..	97
		,, " " " sea	97
		,, disposal of 3, 91, 95, 246	
		,, treatment of	98
		Sewer, definition of	8
		,, egg-shaped form	95
		Sewerage and drainage	215
		Shanks patent	77
		Sherringham's ventilator 149, 190	
		Shield's automatic air-valve ...	177
		Siemen's regenerative burner... ..	205
		"Simplicitas," Doulton's	74
		Simpson & Co., heating in-	
		stallations	171
		Sink, Doulton's wash-up and	
		slop	89
		,, scullery	53, 88, 232
		Sinks	22, 51
		,, and their wastes	88
		Siphonage	58, 61
		Siphonic discharge closet,	
		Jennings & Morley's	77
		Site and foundations	2, 13
		,, position of	22

Q	
Quantity of air required ...	143
,, cubic space re-	
quired for different	
purposes	145

R	
Radiant heat	159
Radiator, electric	172
Radiators and coils	166
Rain-water	114
,, gutters	40
Reflectors, external	199
Refuse	6, 10, 249
,, collection of	91
,, disposal of ... 3, 91, 234	
,, method of disposal of... ..	224
Relative proportions of win-	
dows	197
Repairs... ..	224
Report in reference to a	
country house	225
Report in reference to a town	
house... ..	235
Report in reference to a small	
suburban house	247
Reports generally	4
Requirements of Education	
Department	181
Respiration	137, 142
River water	115
Rivers Pollution Act	97
Roberts' rain-water separator	115
Robin's work on "Technical	
Schools and College Build-	
ing"	182
Rocket used in smoke test ...	217
Roofs, coverings for, &c. 7, 11, 39	
,, state of	230, 242

S	
"S-trap"	64
Safety valves	176

	PAGE		PAGE
Site, protection of	16	Stoneware drain pipes... ..	41
Size of inlets	149	Stop and waste... ..	134
,, outlets	153	Stop-cock, for lead pipes	130, 134
,, pipes	45	Storage batteries	207
Slate cisterns	122	Storage of water	114, 122
Slates	40	Stott's formula for size of gas-	
Slipper-pipe	233	pipes	203
Slop water-closet, Duckett's ...	94	,, governor	204, 249
Sludge remaining from process	103	Stove, electric for cooking ...	172
Small stable, drainage plan		,, Pridgin Teale's	159
of	105, 109	Stoves, close	162, 168
Small suburban house, report		Suitability of site	16
on	247	Sulphuretted hydrogen	142
Small towns, lighting of	202	,, ,, in gas,	
Smith's, Dr. Angus, solution	45, 83	test for	202
Smoke generator, Burn &		Summer larder, position of ...	22
Bailey's Eclipse	218, 222	Sun-light method	206
,, machines, asphyxiator..	218	Sun-window	18
,, prevention	177	Supply of water	214
,, preventer, Belcher's ..	177	Surface drainage	55
,, test for drains	217	Surveys and reports	4
Snow guards	40	Suspended matters in air	142
Socket and spigot of pipes	41	Syphon or U-trap	52
Soil for building purposes	16	Systems of high pressure	
,, pipes	11, 232	heating	167
,, pipes and their ventilation	82		
Soils, clay	15	T	
,, marshy	15	Tank, bacteria at Sutton	100
Solar light	196	Tank system, water supply	173
,, ,, admission to build-		Taps and fittings	133
,, ,, ings	197	"Technical school and college	
Solid floors	37	building" by Robins	182
Somzée - Greyson Intensified		Telescope joints	90
Gaslight Company	205	,, tubes	130
Sources of water	114	Temporary hardness of water,	
Spaces open	7, 11	removal of same	122, 123
Spring-valve	135	Terrace-house drained to front	
Spring-water	116	street	105, 107
Stable gully	56	Terrace-house drained towards	
Stables	56, 109	back	105, 107
,, open roofed ventilation	145	Test for ammonia in gas	202
Staircase, plan and design of	19, 20	Testing of drains, olfactory	216
Staircase and hall, ventilation		Theatres, ventilation and heat-	
of, in house	179	ing of... ..	191
Stanford's joint... ..	43, 49	Throttle-valve	166
Stanton's safety valve	176	Tile-battens	34
Steam pipes	168	Tile-hung walls	43
Steam radiator, separate	190	Tiles	40
Steel armoured insulating		,, glazed	35
conduits	208		

	PAGE
Tinning of valves	134
Tip-up lavatories	86
"Tobin's," tube inlet... ..	150
Tongued and grooved flooring	36
Tongued and ploughed ,, ...	36
Town-house, plan, &c. 26, 105, 111, 235	
Transformer, definition of ...	207
Traps, various	58, 62, 69
Treatment of sewage	98
Trough closets or latrines, Doulton's	79
Turbine driving pumps	127
Turning pin, plumber's	73, 81
Tylor J. & Sons' "Full-way" ball-valve	135
Tyndale asphyxiator	218
Type of covering, Lincrusta ...	36
Types of water-closet pans ..	68
Typical drainage plans	104

U

U-trap	52
Underground cisterns... ..	131
,, drainage traps	51
,, drains, laying of 3, 41	
Union barrel for joining iron piping	132
Unions and junctions of pipes	131
Urinals	87

V

Vacuum, air entering a	147
,, system	157, 191
Valve closet, "Optimus"	75
Velocity of air	139, 147
,, in sewers	95
Ventilation 3, 38, 137, 184, 187	
,, and heating schemes 231, 243, 247	
,, artificial	157
,, fan lights	178
,, flue pipes	155
,, of a billiard-room	195
,, of a chapel, with gallery round three sides	193

	PAGE
Ventilation of a hall, open tim- bered roof	185
,, of a large hall, with flat ceiling	187
,, of a trap	63
,, of churches	181
,, of cottages... ..	178
,, of hospitals	189
,, of houses	179
,, of large wards	190
,, of picture galleries..	191
,, of schools, class rooms	181
,, of sewers	95
,, of theatres	191
,, in report	214
,, natural	157
,, outlets, position and size	153

W

Wall coverings, internally ...	35
,, surface	184, 187
Walls, building of	7, 30
,, state of... ..	228, 241
Warmed air	160
Warren-Webster's steam heat- ing apparatus	169
"Wash-down" closet... ..	72
"Wash-out" closet	71
Waste for basin	133
Wastes of baths	84
,, of lavatories	86
,, of sinks	88
Water-Act, Metropolis	85
,, carried system of drainage	94
,, closets, various types 21, 68, 180	
,, consumption of..	114, 118
,, distillation of	119
,, distribution of	114, 123
,, examination of	114, 121
,, ground	14
,, hardness of	114, 122
,, impurities in	114, 119
,, nitrification of	120
,, seal in traps	62
,, storage of	122, 144
,, supply 128, 214, 233, 246, 248	
,, supply and pollution 3, 114	

	PAGE		PAGE
Water-waste preventers and flushing cisterns ...	80	Windows, relative proportions of ...	197
„ wheel, and water-wheel driving pump ..	127	„ state of ...	230, 242
„ works, Darjeeling ...	120	Winser's grease trap ...	53
Well water ...	116	Wiped joints ...	81
Wells, artesian... ..	118	Wiring for electric lighting ...	208
Wellsbach Incandescent and Gaslight Company ...	205	Wooden casing for wiring ...	200
Wheel valve ...	134	Workmen's cottages ...	26
White-glazed bricks ...	48	Workshop Acts ...	9
„ lead ...	35	Wright's fixing blocks ...	34
“ Wide-fronted ” basin, Hellyer's ...	88		
Willesden paper ...	39	Y	
Windows ...	8, 19	Yard gully ...	55
„ Morris's rule for size of ...	198		
„ position of ...	198	Z	
		Zinc-white ...	35

WELLCOME LIBRARY

14 PRIZE MEDALS, including Gold Medal, Brussels Exhibition, 1897.
HIGHEST AWARD WHEREVER EXHIBITED.

Lincrusta-Walton The Sunbury
 Wall
 Decoration.

The King of Wall Hangings.

Is not merely "Substantial," but is the ONLY
 Material for Walls, Ceilings, &c., &c., that is

SOLID in COLOUR! SOLID in RELIEF! and SOLID in VALUE

To meet the ever-increasing demand for . . .

**Inexpensive Dadoes, Ceilings and
 Fillings in LINCRUSTA=WALTON,**

The Manufacturers have issued a Book containing many
 Patterns at the uniform price of . . .

— One Shilling per Yard.

The Manufacturers have also issued a New and Beautiful Range of

**HIGH-RELIEF AND
 LOW-RELIEF CEILINGS,
 FRIEZES, &c., &c., in**

CAMÉOID

Their new Embossed Decorative Material for Ceilings and Walls. It will be found
 a material thoroughly reliable, and of the highest quality.

BEAUTIFUL AS PLASTER—

AT MUCH LESS COST!

Fredk. Walton & Co., Ltd.,

SOLE MANUFACTURERS AND PATENTEES,

1 & 2, NEWMAN STREET, LONDON, W.

Telegrams: "Lincrusta-Walton, London." Telephone: No. 3769, Gerrard.

Names and Addresses of Advertisers.

(For Analysis of Advertisements see opposite page.)

	See Page
BILLING'S BURNER SYNDICATE, LTD., 180, Wardour Street, London, W. ...	ii
BRIGGS, WILLIAM, Composition Works, Dundee	v
BROAD & CO., LTD., South Wharf, Paddington, London, W.	x
BURN BROS., 23 & 24, Charing Cross, London, S.W.	viii
LOVE & WYMAN, LTD., Great Queen Street, London, W.C.	xvi
NICHOLLS & CLARKE, Shoreditch, London	vi & vii
ROSSER & RUSSELL, LTD., 22, Charing Cross, London, S.W.	xi
SEYSEL AND METALLIC LAVA ASPHALTE CO. (Mr. H. Glenn), 42, Poultry, London, E.C.	iv
SPRAGUE & CO., LTD., 4 & 5, East Harding Street, Fetter Lane, London, E.C.	xv
WALTON, F. & CO., LTD., 1 & 2, Newman Street, Oxford Street, London, W.	i
WILLIAMS, ALFRED & CO., 814, Old Ford Road, Bow, London, E. ...	v
WILLIAMS, G. A., & SON, 21, Queen's Road, Bayswater, London, W. ...	iii
WINSER & CO., LTD., 52, Buckingham Palace Road, London, S.W. ...	ix

No more Mantles!

A NEW
INCANDESCENT GAS LIGHT.

BILLING'S PATENT
"Non-Mantle" Gas Burner

5/6 Complete, Postage 6d. extra.

Illustrated Catalogues Post Free.

BILLING'S BURNER SYNDICATE, Ltd.

180, WARDOUR ST., LONDON, W.

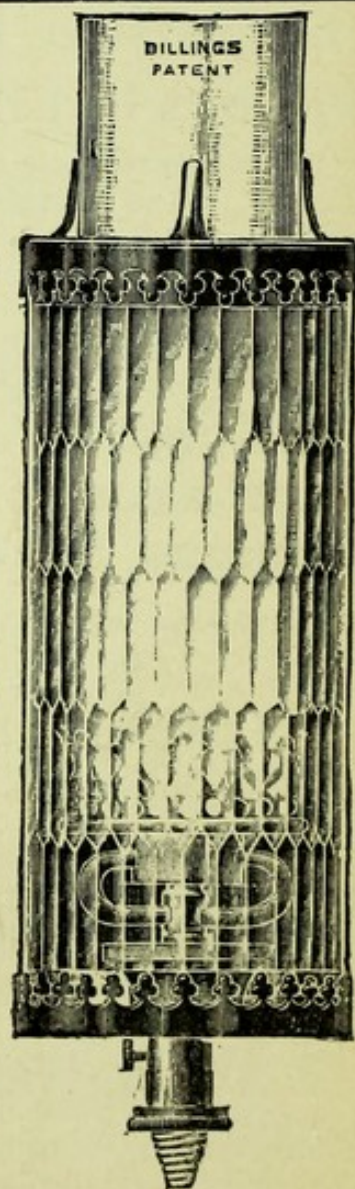

Analysis of Advertisements.

(For Alphabetical List of Advertisers see opposite page.)

ARTESIAN WELLS— Williams, Alfred, & Co.	LITHOGRAPHY— Love & Wyman, Ltd. Sprague & Co., Ltd.
ASPHALTES— Seysssel & Metallic Lava Asphalte Co., Ltd.	NON-MANTLE GAS BURNER— Billing's Burner Syndicate, Ltd.
BLNDS (of all kinds)— Williams, G. A., & Son.	PRINTING— Love & Wyman, Ltd. Sprague & Co., Ltd.
BUILDING MATERIALS— Broad & Co., Ltd.	PROCESS BLOCKS— Love & Wyman, Ltd. Sprague & Co., Ltd.
CAMÉOID CEILING DECORATION— Walton, F., & Co., Ltd.	PUMPS— Williams, Alfred, & Co.
DAMP PROOF COURSES— Briggs, W. Seysssel & Metallic Lava Asphalte Co., Ltd.	SANITARY APPLIANCES, &c. Broad & Co., Ltd. Burn Brothers. Nicholls & Clarke. Winser & Co., Ltd.
DRAIN STOPPERS AND TESTERS— Burn Brothers. Nicholls & Clarke. Winser & Co., Ltd.	SCULLERY SINKS— Broad & Co., Ltd.
HEATING— Rosser & Russell, Ltd.	TENAX ROCK BUILDING COMPOSITION— Briggs, W.
INCANDESCENT GAS LIGHTING— Billing's Burner Syndicate, Ltd.	VENTILATION— Rosser & Russell, Ltd.
INK-PHOTO PROCESS— Sprague & Co., Ltd.	WALL AND CEILING COVERINGS— Walton, F., & Co., Ltd.
LAVATORY BASINS— Nicholls & Clarke.	WATER CLOSETS— Nicholls & Clarke.
LINCRUSTA-WALTON— Walton, F., & Co., Ltd.	WATER SUPPLY— Williams, Alfred, & Co.
	WINDMILLS— Williams, Alfred & Co.

BLINDS

OF ALL KINDS.

G. A. WILLIAMS & SON,

21, QUEEN'S ROAD,

BAYSWATER, LONDON, W.

ASPHALTE.

The Seyssel and Metallic Lava Asphalte Co.

(Mr. H. GLENN),

Importers, Manufacturers, and Contractors

FOR

**SEYSSEL AND METALLIC LAVA
ASPHALTES,**

SUITABLE FOR

Asylum Floors,
Barn Floors,
Barrack Floors,
Coach Houses,
Corn, Cotton, Hop,
and Seed Floors,
Corridors,
Court Yards,
Cow Sheds,
Damp Courses,
Dairy Floors,

Dens for Animals,
Flat Roofs,
Foot Pavements,
Goods Sheds,
Granaries,
Laundry Floors,
Malt Rooms,
Milk Rooms,
Piggeries,
Prison Cells,
Railway Arches,
Bridges, &c.

Reservoirs,
Railway Platforms,
Sea-Water Tanks,
Stables,
Swimming Baths,
Terraces,
Tun Room Floors,
Vertical to Face of
Walls,
Warehouse Floors,
Wine Cellars,
Waterworks.

“SEYSSEL” should be used in all cases for exposed out-door purposes.

THE METALLIC LAVA ASPHALTE

Admirably supplies the place of “Seyssel” for many in-door purposes, at a much less cost.

Prices and further particulars upon application to the

Office : 42, Poultry, E.C., LONDON.

The Company only uses the very finest quality of materials, together with the best procurable workmanship, and undertakes to

GUARANTEE ALL WORK.

SPECIAL NOTICE.—When applying for prices for Asphalte laid complete, please state thickness, quantity, locality, and purpose for which it is to be used.

Country Builders supplied with Asphalte in bulk, with instructions for laying.

Particular attention is paid to Dairy and Tun Room Floors.

**ASPHALTE CONTRACTORS TO THE FORTH BRIDGE COMPANY,
THE RIO DE JANEIRO WATERWORKS,
THE MALIGAKANDA RESERVOIR, COLOMBO, CEYLON,
and other Waterworks,
all of very considerable magnitude.**

✻ WINDMILLS. ✻

“The Lion.”

Made of Steel, with Steel Lattice-work Tower; also the **HALLADAY**, with Wooden Fans, for Pumping from Deep or Shallow Wells, and for Driving Dynamos and Sewage Pumps.



PUMPS OF ALL DESCRIPTIONS.

ARTESIAN WELLS.

Trial Borings for Foundations.

DRIVEN TUBE WELLS. DRIVING APPARATUS.

Apply for Lists to—

Alfred Williams & Co.,

Hydraulic Engineers.

CONTRACTORS TO H.M. GOVERNMENT,

814, OLD FORD RD., BOW, LONDON, E.

Telegraphic Address: “VENTULUS, LONDON.”

**W
A
T
E
R

S
U
P
P
L
Y**

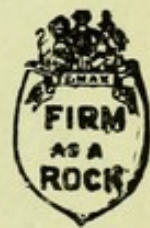
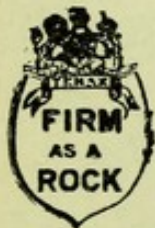

TENAX ROCK BUILDING COMPOSITION

Renders Walls ABSOLUTELY DAMP-PROOF, and almost doubles their strength.

It has been specified and extensively used all over England in more than **180** different towns during the past ten years (many of the orders being repeat orders) in CHURCHES, ASYLUMS, TECHNICAL SCHOOLS, WAR DEPARTMENT BUILDINGS, MANSIONS, WAREHOUSES, CELLARS, SWIMMING BATHS, NEWSPAPER OFFICES, INFIRMARIES, ORDINARY DWELLING-HOUSES, STRONG ROOMS, LIBRARIES, UNDERGROUND CONVENIENCES, SEWAGE WORKS, ETC.

Also at SANDRINGHAM for H.R.H. THE PRINCE OF WALES.

A half-inch section in the centre of the wall is the thickness generally used. The price is about one-third less than any similar Composition, and does one-fifth more area.

Pamphlets, giving details and testimonials, post free.

**ITS USE INFRINGES NO PATENT WHATEVER.
THIS IS GUARANTEED.**

SOLE MAKER—

WILLIAM BRIGGS,
Composition Works, DUNDEE.

Telegrams: “CEMENT, DUNDEE.”

THE "ADDISON"

PATENT DRAIN STOPPER

PERFECTLY
SOUND JOINT.

EASILY
APPLIED.

NO PINCHING
OF THE
RUBBER.

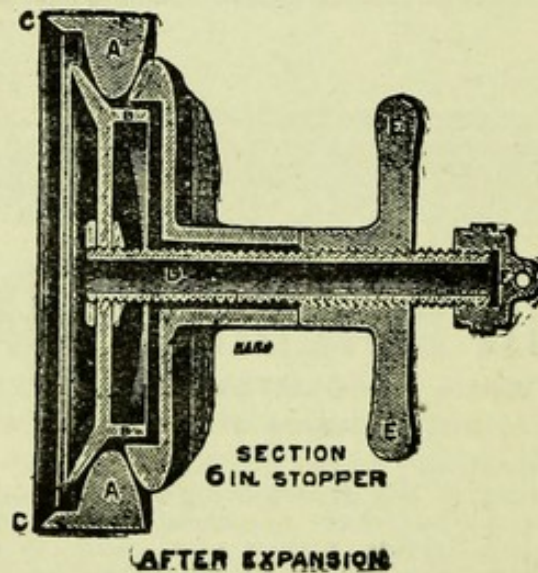
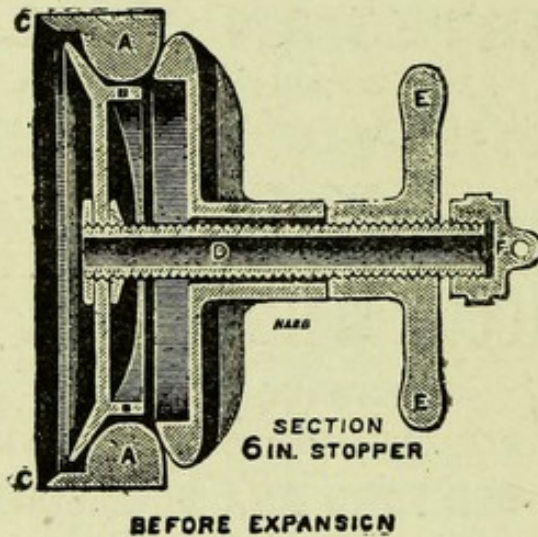

THE GREATER
THE
PRESSURE
THE MORE
SECURE
THE
JOINT.

FOR TESTING DRAINS BY WATER,
SMOKE, &c.

NICHOLLS & CLARKE,
SHOREDITCH, LONDON.

ROSSER & RUSSELL, LTD.

Engineers,

*SPECIALISTS FOR WARMING AND
VENTILATION.*

WARMING.

LOW PRESSURE HOT WATER,
LOW PRESSURE STEAM,
EXHAUST STEAM under Atmospheric
Pressure,
SMALL PIPE (or High Pressure) SYSTEM,
GILLED AIR WARMERS, &c.

VENTILATION,

Mechanical or Natural.

INDUCED CURRENT AND PLENUM SYSTEMS.

Full Particulars and References to Works Executed on application.

OFFICES - { 22, Charing Cross, LONDON, S.W.
31a, Colmore Row, BIRMINGHAM.

WORKS—HAMMERSMITH, W.

“The Builder” Student’s Series.

Crown 8vo, Price 3s. 6d., post free.

**SPECIFICATIONS FOR
BUILDING WORKS
AND HOW TO WRITE THEM.**

A MANUAL FOR ARCHITECTURAL STUDENTS

BY

FREDERIC RICHARD FARROW, F.R.I.B.A.,

*Goawin Bursar (1884) Lecturer at the Architectural Association on
Construction, &c.*

THIS Manual is written with a view to meet the requirements of the student, to show him how he should write a specification, so that when he has learnt the method and general principles, he may apply them to the particular exigencies of any building he may design. The examples given are intended to act as illustrations, not as precedents to be exactly copied in every instance.

London:

D. FOURDRINIER, “BUILDER” OFFICE, 46, CATHERINE STREET, W.C.;

ALSO OF

WHITTAKER & CO., Paternoster Square, E.C.

“The Builder” Student’s Series.

Crown 8vo, Price 3s. 6d., post free.

QUANTITIES

AND

QUANTITY TAKING.

BY

W. E. DAVIS,

Surveyor.

THE Author in producing this book has endeavoured to make it essentially a practical one, the methods set forth being generally those of his own practice, allowing for certain modifications found necessary to suit special circumstances. The intention being to make it a reliable handbook for the Student pure and simple, a hard and fast line has been drawn, limiting its scope to the method of procedure in the production of a good Bill of Quantities, leaving out those questions of Law and other matters that do not come within the province of the Student for whom the work is designed.

The examples given, whilst intentionally simple, to avoid confusing the Student by a mass of detail, will be found to cover almost every phase of the subject.

London:

D. FOURDRINIER, “BUILDER” OFFICE, 46, CATHERINE STREET, W.C.;

ALSO OF

WHITTAKER & CO., Paternoster Square, E.C.

“The Builder” Student’s Series.

Second Edition. Crown 8vo, Price 5s., post free.

CARPENTRY AND JOINERY.

A TEXT BOOK FOR

Architects, Engineers, Surveyors, and Craftsmen.

BY

BANISTER F. FLETCHER, A.R.I.B.A.,

AND

H. PHILLIPS FLETCHER, A.R.I.B.A., A.M.I.C.E.

THE Authors have endeavoured to meet the requirements of the craftsman, and at the same time to produce a work that will be useful to the Professional man in the designing of the various structures. They have also endeavoured to consider the desires of those who are likely to become candidates for the examination of the City and Guilds’ Institute, the Carpenters’ Company, and the Institute of Certified Carpenters, &c. Also for the examination in these subjects by the R.I.B.A. and the Surveyors’ Institution, &c. The authors have had considerable experience in examining candidates in these subjects, and they feel that some such work would be welcomed by these candidates.

London :

D. FOURDRINIER, “BUILDER” OFFICE, 46, CATHERINE STREET, W.C. ;

ALSO OF

WHITTAKER & CO., Paternoster Square, E.C.

SPRAGUE & CO., Ltd, Lithographers, Printers, &c.,

having devoted their attention for several years to the requirements of the Architectural Profession, are enabled to offer special facilities for the execution of the various descriptions of work detailed below, on moderate terms and with strict punctuality.

BILLS OF QUANTITIES, SPECIFICATIONS, REPORTS, &c.

Special Writers are on the premises for these, and being constantly engaged upon them, they are thoroughly conversant with the technical terms and peculiarities of this work. Certified Copies of Bills can be supplied in a few hours if required; or, if received in the evening, by 9 o'clock next day; or by return of post to the country.

FAIR COPIES of Specifications, Contracts, Reports for Competitions, Dimensions, Accounts, &c., neatly and accurately executed.

ELEVATIONS, PLANS, AND SECTIONS FOR TENDERS. Tracings or Manuscript Copies made, or Architects' own Drawings lettered and finished.

PLANS OF ESTATES, with or without Perspective Views, tastefully lithographed and printed in colours, or highly shaded-up by hand.

PHOTO-LITHOGRAPHY rapidly executed in a superior manner.

"INK-PHOTO" process reproduces Water-Colour or Pencil Drawings or Photographs with the same facility as Pen and Ink Drawings in line. *Vide* the illustrations in "The Architect," "The Builder," &c., &c. In cases of especial emergency, any class of Drawing may be photographed and returned in course of a few hours.

PROCESS BLOCKS. We are now in a position to supply Half-tone or Line Blocks for printing with type, at short notice.

PHOTOGRAPHY. A thoroughly competent operator will be sent to take Photographs of Buildings at short notice.

CERTIFICATE BOOKS for Instalments always in stock, 3s.; a larger size, with Receipt, 5s. Bill, Dimension, and Specification Paper, Circulars, Headed Note or Letter Paper, and Memo. Forms Lithographed or Printed.

DRAWING PAPERS, Tracing Papers, &c., Office Stationery, and Sundries of every kind.

4 & 5, EAST HARDING STREET, FETTER LANE, LONDON, E.C.

Telephone No. : 2675, Gerrard.

Telegraphic Address : "Jetblack, London."

Printing



RAPIDLY EXECUTED,
IN GOOD STYLE,
AT MODERATE PRICES,

BY . .

LOVE & WYMAN,
LIMITED,

Great Queen Street, London, W.C.,

And 3 & 4, GREAT WINCHESTER STREET, E.C.,

Who will be pleased to furnish inclusive estimates for the production
. . . and supply of . . .

Newspapers, Magazines, and Periodical Literature,
Illustrated Catalogues and Price Lists,
High-class Book Work.

Pamphlets, Reports, Company Prospectuses,
Law Work, Circulars,

*And every description of General Printing, Lithography,
and Bookbinding,
Engravings, Process Blocks, and Electros.*

~~~~~  
COMMERCIAL, GENERAL, AND COMPANY ACCOUNT BOOKS  
A SPECIALTY.

